



S+S REGELTECHNIK



# SENSOR TECHNOLOGY & FIELD DEVICES

**5** JAHRE GARANTIE  
★★★★★  
YEARS WARRANTY  
MADE IN GERMANY



S+S REGELTECHNIK

## In Focus: Sustainable Solutions

The commissioning of our giga-factory has been successfully completed. This gives us all the required means to expand our product lines and establish S+S as your full-service provider for sustainable sensor technology in facility and systems engineering.

The grown family of our **RYMASKON**<sup>®</sup> operating devices for networked room automation enables measurable energy and cost savings at increased well-being. New **PREMASGARD**<sup>®</sup> double pressure sensors score with patented multi-functionality. And with our expanded **AERASGARD**<sup>®</sup> environmental sensor system you can record all relevant parameters for a healthy living and working environment.

In addition, benefit from our completely redesigned webshop as your one-stop basis for more flexibility and convenience when ordering all S+S catalogue items.

### Tino Schulze

General Manager  
S+S Regeltechnik GmbH<sup>®</sup>

### Heiko Linke

General Manager  
S+S Regeltechnik GmbH<sup>®</sup>







# Clear Priority: Sustainability

The 17 Sustainable Development Goals (SDG) of the United Nations outline what we need to accomplish in order to leave behind a planet worth living for future generations. For S+S as a responsible company, this results in three primary missions:

## ENVIRONMENTAL SENSING

S+S sensor devices for CO<sub>2</sub>, VOC and fine dust (PM) enable sustainable solutions to optimise indoor air quality.

1

**OUR MISSION:** We help create a healthy and productive room climate in which people feel well.

## ENERGY EFFICIENCY

The broad range of S+S devices for facility automation enables a sustainably efficient energy management.

2

**OUR MISSION:** We contribute to minimising energy consumption and harmful emissions

## DURABILITY

S+S products are known for their multi-functionality and quality. This is backed by a 5 years warranty.

3

**OUR MISSION:** We save resources and effort with smart sensor technology for sustainable buildings.



With the second construction phase of our new giga-factory, we have significantly expanded our production capacities, already. The third phase is nearing completion.





## ETHER CAT P MEASURING TRANSDUCER



### Temperature sensors

ATM 2-EtherCATP	Outside temperature sensor	<b>NEW</b>	031
TM 65-EtherCATP	Duct / immersion / screw-in temperature sensor	<b>NEW</b>	033
MWTM-EtherCATP	Mean-value temperature sensor	<b>NEW</b>	039
HFTM-EtherCATP	Sleeve sensor with cable	<b>NEW</b>	041
ALTM 2-EtherCATP	Surface-contact temperature sensor with cable	<b>NEW</b>	043

### Humidity sensors

AFTF-EtherCATP	On-wall humidity/temperature sensor	<b>NEW</b>	047
KFTF-EtherCATP	Duct humidity/temperature sensor	<b>NEW</b>	051

### Pressure sensors

PREMARGARD® 612x-EtherCATP	Pressure measuring transducer (Differential pressure, volume flow)	<b>NEW</b>	055
-------------------------------	--	------------	-----

### Special accessories

see chapter Accessories		<b>NEW</b>	651
-------------------------	--	------------	-----

## EtherCAT<sup>®</sup> P

Fast standard industrial bus with communication and power on one cable



## BUS-CAPABLE MEASURING TRANSDUCER



### Room control units

RYMASKON® 200	Room control units	087
RYMASKON® 400	Room control units	085
RYMASKON® 500	Room control units (Thermostat)	<b>NEW</b> 083
RYMASKON® 600	Room control units (Controller)	<b>NEW</b> 079
RYMASKON® 700	Room control units (Interface)	<b>NEW</b> 075
RFTF-Modbus-xx	Room control units	089
RTM1-Modbus	Room control units	091
RFTM-CO2-Modbus-P	Room control units	147
FSFTM-Modbus-xx	Room control units, In-wall	113/149

### Temperature sensors

RTM1-Modbus	Room temperature sensor	091
RPTM1-Modbus-T3	Room pendulum temperature sensor	107
RPTM2-Modbus-T3	Room pendulum temperature sensor	109
HFTM-Modbus-T3	Sleeve sensor with cable	101
ALTM1-Modbus-T3	Surface-contact temperature sensor	103
ALTM 2-Modbus-T3	Surface-contact temperature sensor with cable	105
ATM 2-Modbus-T3	Outside temperature sensor	093
TM 65-Modbus-T3	Duct / immersion / screw-in sensor	095
MWTM-Modbus-T3	Mean-value temperature sensor	099

### Humidity sensors

FSFTM-Modbus	In-wall humidity temperature sensor	113
RFTF-Modbus	Room humidity / temperature sensor	111
RPFTF-Modbus-T3	Room pendulum humidity temperature sensor	119
VFTF-Modbus-T3	Showcase humidity temperature sensor	121
AFTF-Modbus-T3	On-wall humidity temperature sensor	115
KFTF-Modbus-T3	Duct humidity temperature sensor	117
TW-Modbus-T3	Dew point control switch	125

### Pressure sensors

PREMARGARD® 232x-Modbus-T3	Pressure measuring transducer (Differential pressure)	129
PREMARGARD® 714x-Modbus	Pressure measuring transducer (Differential pressure, volume flow)	<b>NEW</b> 133
PREMARGARD® 724x-Modbus	Pressure measuring transducer (Differential pressure, volume flow) with dual pressure sensor	<b>NEW</b> 139
PREMARGARD® 814x-Modbus	Duct sensor for humidity, temperature with Pressure measuring transducer (differential pressure, volume flow)	143

### CO2, VOC and fine dust sensor

FSFTM-CO2-Modbus	In-wall sensor for moisture, temperature, Air quality (VOC), CO2	149
RFTM-LQ-PS-CO2-Modbus	Room sensor for moisture, temperature, air quality (VOC), CO2 and fine dust (PM)	<b>NEW</b> 147
AFTM-LQ-CO2-Modbus	On-wall sensor for humidity, temperature, Air quality (VOC), CO2	153
KFTM-LQ-CO2-Modbus	Duct sensor for humidity, temperature, Air quality (VOC), CO2	157

### Special accessories

LA-Modbus	Line termination device	159
KA2-Modbus	Communication adapter	161
see chapter Accessories		650





S+S REGELTECHNIK

## POWER IO BUILDING AUTOMATION



### powerIO® Main components

Box	Decentralised automation box	067
Line	Hybrid cable	<b>NEW</b> 067
Start Unit	Switch	067
Starter Set	with basic components	066

### powerIO® Expansion components

Bluetooth Dongle	Communication with powerIO®-App	069
Rio1	Expansion box non-communicative sensors / actuators	068
Rio 4DI / 8DI	Digital input modules	<b>NEW</b> 068
Hub	Distributor	068
Booster	Power output amplification	<b>NEW</b> 068
HK Distributor	Thermal drives	<b>NEW</b> 068
Y Distributor Box	RS485 nodes	<b>NEW</b> 068
BSK Modules	Fire damper	<b>NEW</b> 069

### powerIO® Expansion cards

C100_ETH	Ethernet	070
C100_RS485	RS485	070
C100_RS232	RS232	070

### powerIO® Special accessories

see product page		070 / 071
------------------	--	-----------



The system for decentralised building automation

**NEW**



## RADIO SENSOR RADIO TRANSMITTER / RADIO RECEIVER



### KYMASGARD® 9000 EnOcean radio transmitter

RFTM-FSE	Room temperature radio sensor	613
RFTM-FSE-ST	Room control unit / Room temperature radio sensor	613
RFTM-LQ-FSE	Room radio sensor for humidity, temperature and air quality	613
RFTM-BW-FSE	Room radio sensor for humidity, temperature and motion	613

### EnOcean radio transmitters

RTF2-FSE	Room temperature radio sensor	614
RFTF2-FSE	Room humidity / temperature radio sensor	614
RTF2-FSE-P	Room temperature radio sensor	615
RFTF2-FSE-P	Room humidity / temperature radio sensor	615
RTF2-FSE-PT	Room temperature radio sensor	616
RFTF2-FSE-PT	Room humidity / temperature radio sensor	616
RTF2-FSE-PD	Room temperature radio sensor	617
RFTF2-FSE-PD	Room humidity / temperature radio sensor	617
RTF2-FSE-PDT	Room temperature radio sensor	618
WT-FSE	Wall pushbutton	619
FK1-FSE	Door/window contact	621
HT4-FSE	Hand-held remote control unit	620
IN400-FSE-UP	Pushbutton interface, in-wall	628
AFTF-HK-FSE	Outside radio sensor for humidity, temperature and light intensity	632
AWFS-HK-FSE	Outside radio sensor for wind strength and light intensity	633

### EnOcean radio signal receivers

JA100-FEM-UP	Venetian blind actuator, in-wall	623
SA100-FEM-UP	Switching actuator, in-wall	624
SA200-FEM-UP	Switching actuator, in-wall	625
TA100-FEM-UP	Thermostat actuator, in-wall	626
TA200-FEM-UP	Thermostat actuator, in-wall	627
JA200-FEM-UP	Venetian blind actuator, on-wall	629
SA400-FEM-UP	Switching actuator, on-wall	630
SV600-FEM-AP	Dimming actuator, on-wall	631

### EnOcean-Gateway

GW-RS485-FEM	Gateway for RS485 bus	622
--------------	-----------------------	-----

### EnOcean communication

USB-FEM	USB communication stick	611
---------	-------------------------	-----



enocean®

## TEMPERATURE SENSORS PASSIVE



### Room sensors

DTF	In-ceiling temperature sensor	185
RTF	Room temperature sensor, on-wall	166
FSTF	Room temperature sensor, in-wall	178
RPTF 1	Room pendulum temperature sensor	246
RPTF 2	Room pendulum temperature sensor	247
RSTF	Room radiation temperature sensor	249
RTF-xx	Room control units, on-wall	171
FSTF-xx	Room control units, in-wall	180

### Cable sensors, surface-contact sensors, outdoor sensors

TF 43/65-F	Immersion / duct / screw-in sensor	199
HTF	Sleeve temperature sensor with cable	236
OFTF	Surface temperature sensor	241
ALTF 1	Surface-contact temperature sensor	242
ALTF 2/02	Surface-contact temperature sensor	245/244
ATF 1/01	Outside temperature sensor	187/186
ATF 2	Outside temperature sensor	189

### Duct, immersion, screw-in sensors

TF 43/65	Duct / immersion / screw-in sensor	194/192
TF 43/65-F	Duct / immersion / screw-in sensor with cable	199
TF 54	Duct / immersion / screw-in sensor	210
MWTF/SD	Mean-value temperature sensor	205
ETF 6	Screw-in sensor with neck tube	218
ETF 7	Screw-in sensor, fast-acting	207
RGTF 2	Smoke gas screw-in sensor	231
RGTF 1	Smoke gas duct sensor	225
HTF	Sleeve sensor with cable	236

### Radiation temperature sensors

ASTF	On-wall radiation temperature sensor	248
------	--------------------------------------	-----

## TEMPERATURE SENSOR ACTIVE MEASURING TRANSDUCER



### Room sensors

RTM 1	Room temperature measuring transducer	253
FSTM	Room temperature sensor, in-wall	255
RPTM 1	Room pendulum temperature measuring transducer	313
RPTM 2	Room pendulum temperature measuring transducer	315
HSM	Top-hat rail measuring transducer	317

### Cable sensors, surface-contact sensors, outdoor sensors

HFTM	Sleeve sensor with measuring transducer	297
HFTM-VA	Sleeve sensor with measuring transducer (Stainless steel housing Tyr 2E)	301
ALTM 1	Surface-contact temperature measuring transducer	303
ALTM 2	Surface-contact temperature measuring transducer	307
ALTM 2-VA	Surface-contact temperature measuring transducer (Stainless steel housing Tyr 2E)	311
ATM 2	Outside temperature measuring transducer	259
ATM 2-VA	Outside temperature measuring transducer (Stainless steel housing Tyr 2E)	263

### Duct, immersion, screw-in sensors

TM 43/65	Duct / immersion / screw-in temperature measuring transducer	267
TM 54	Duct / immersion / screw-in temperature measuring transducer	277
MWTM/SD	Mean-value temperature measuring transducer	273
RGTM 1	Smoke gas temperature measuring transducer	285
RGTM 2	Smoke gas temperature measuring transducer	291

## TEMPERATURE CONTROLLERS / THERMOSTATS



### Room temperature controllers

RTR-B	Room temperature controller	321
RTR-S	Room temperature controller, fan coil controller	323
RTR-E-UP	Room temperature controller, clock thermostat	327
TET	Top hat rail measuring transducer	359

### Built-in controllers, duct controllers

ETR	Built-in temperature controller	335
KTR	Duct temperature controller	341
TR 040/060	Temperature controller	328
TR 22	Temperature controller	329
TR 04040	Temperature controller, two-step	330
TR xx-F	Temperature controller with remote sensor	331

### Thermostats

ALTR xx	Surface-contact thermostats	344/345
FST	Frost protection thermostat, mechanical	349
FST-K	Duct frost protection thermostat, mechanical	353
FS-20	2-phase frost protection thermostat, two-step, switching	357

## HUMIDITY SENSORS

### HUMIDITY CONTROLLERS / HYGROSTATS



#### Room sensors

RFF/RFTF	Room humidity sensor, on-wall	367
FSFM/FSFTM	Room humidity sensor, in-wall	369
RPFF-SD	Room pendulum humidity sensor	415
RPFF/RPFTF	Room pendulum humidity sensor	419
RPFF/RPFTF-25	Room pendulum humidity sensor, pluggable	423
VFF/VFTF	Showcase humidity sensor	427
DFF/DFTF	In-ceiling humidity sensor	373

#### On-wall sensors, outdoor sensors

AFF/AFTF-SD	On-wall humidity sensor	377
AFF/AFTF	On-wall humidity sensor	382
AFF/AFTF-20	On-wall humidity sensor	385
AFF/AFTF-25	On-wall humidity sensor, pluggable	383
AFTF-20-VA	On-wall humidity sensor (Stainless steel housing Tyr 2E)	391
AAVTF	On-wall humidity sensor	395

#### Duct sensors

KFF/KFTF-SD	Duct humidity sensor	400
KFF/KFTF	Duct humidity sensor	401
KFF/KFTF-20	Duct humidity sensor	403
KFTF-20-VA	Duct humidity sensor (Stainless steel housing Tyr 2E)	409
KAVTF	Duct humidity sensor	413

#### Hygrostats

RH-2	Room hygrostat, one-step	429
KH-10	Duct hygrostat, one-step	441
KH-40	Duct hygrostat, one-step	443
AH-40	On-wall hygrostat, one-step	435
RHT	Room hygrothermostat	428
RHT-30	Room hygrothermostat, two-step	433
KHT-30	Duct hygrothermostat, two-step	447
AHT-30	On-wall hygrothermostat, two-step	439

#### Control switches

KW/KW-SD	Condensation control switch	451/450
TW	Dew point control switch	455
LS	Leakage sensor	457





S+S REGELTECHNIK

**PRESSURE SENSORS  
PRESSURE CONTROLLERS / SWITCHES****for gaseous media**

<b>PREMASGARD®</b> 111x / 112x / SD	Pressure measuring transducer [mbar/Pa], Differential pressure sensor	<b>472 / 473</b>
<b>PREMASGARD®</b> 211x / 212x / SD	Pressure measuring transducer [mbar/Pa], Differential pressure sensor	<b>467 / 466</b>
<b>PREMASGARD®</b> 711x	Pressure measuring transducer [mbar/Pa], Differential pressure sensor	<b>479</b>
<b>PREMASGARD®</b> 711x-VA	Pressure measuring transducer [mbar/Pa], Differential pressure sensor (Stainless steel housing Tyr 2E)	<b>485</b>
<b>PREMASGARD®</b> 722x	Pressure measuring transducer [mbar/Pa], Differential pressure sensor <b>with dual pressure sensor</b>	<b>NEW 491</b>
<b>PREMASREG®</b> 711x	Pressure measuring transducer [mbar/Pa], Differential pressure switch	<b>497</b>
<b>PREMASREG®</b> 711x-VA	Pressure measuring transducer [mbar/Pa], Differential pressure switch (Stainless steel housing Tyr 2E)	<b>503</b>
<b>ALD</b>	Measuring transducer [mbar] atmospheric pressure	<b>517</b>
<b>DS 1 / DS2</b>	Differential pressure switch [mbar/Pa]	<b>521</b>
<b>for volume flow</b>		
<b>PREMASREG®</b> 716x	Pressure measuring transducer [mbar/Pa], Volume flow / differential pressure switch	<b>509</b>
<b>PREMASREG®</b> 716x-VA	Pressure measuring transducer [mbar/Pa], Volume flow / differential pressure switch (Stainless steel housing Tyr 2E)	<b>515</b>
<b>for liquid media</b>		
<b>SHD / SHD-SD</b>	Pressure measuring transducer [bar]	<b>523</b>
<b>SHD400</b>	Pressure measuring transducer [bar]	<b>525</b>

**LIGHT INTENSITY SENSORS  
MOTION DETECTORS / PRESENCE DETECTORS****Light intensity sensors**

<b>AHKF</b>	Outdoor light intensity sensor	<b>535</b>
<b>RHKF</b>	Room light intensity sensor	<b>534</b>
<b>DHKF</b>	In-ceiling light intensity sensor	<b>537</b>

**Motion detectors**

<b>ABWF</b>	Outdoor motion detector	<b>539</b>
<b>RBWF</b>	Room motion detector	<b>538</b>
<b>DBWF/DBWF-C</b>	In-ceiling motion detector	<b>541</b>

**Motion and light intensity sensors**

<b>ABWF/LF</b>	Outdoor motion detector / light intensity sensor	<b>545</b>
<b>RBWF/LF</b>	Room motion detector / light intensity sensor	<b>543</b>
<b>DBWF/LF/FTF</b>	In-ceiling sensor for temperature, humidity, motion and light intensity	<b>547</b>

**IMMERSION SLEEVES  
ACCESSORIES / SPARE PARTS****Immersion sleeves**

<b>TH08</b>	Immersion sleeves for temperature sensors	<b>636</b>
<b>TH</b>	Immersion sleeves for temperature sensors	<b>638</b>
<b>THR</b>	Immersion sleeves for temperature controllers	<b>640</b>
<b>THE</b>	Immersion sleeves for sleeve sensors	<b>642</b>

**Mounting accessories**

<b>F-xx</b>	Mounting flanges	<b>644 / 645</b>
<b>KRD-04</b>	Capillary tube leadthrough, plastic	<b>644</b>
<b>MK-xx</b>	Mounting clamps	<b>645</b>
<b>ESSH</b>	Welding protection sleeve	<b>646</b>
<b>Others</b>	see chapter Accessories	<b>644</b>

**AIR QUALITY  
SENSORS****Gas mixture sensor (VOC)**

\* W with changeover contact

<b>RLQ-SD</b>	Room air quality sensor	<b>557</b>
<b>RLQ-W</b>	Room air quality sensor	<b>* 557</b>
<b>KLQ-SD</b>	Room air quality sensor	<b>589</b>
<b>KLQ-W</b>	Room air quality sensor	<b>* 589</b>

**Carbon dioxide sensor (CO2)**

<b>FSC02</b>	Room CO2 sensor, in-wall	<b>575</b>
<b>FSTM-CO2</b>	Room temperature / CO2 sensor, in-wall	<b>575</b>

<b>RCO2-AS NT ST</b>	<b>CO2 traffic light with signal tone,</b> table-top unit with plug-in power supply unit, stainless steel stand	<b>NEW 561</b>
----------------------	---	----------------

<b>RCO2-AS NT</b>	<b>CO2 traffic light with signal tone,</b> wall unit with plug-in power supply unit	<b>NEW 561</b>
-------------------	--	----------------

<b>RCO2-AS UPNT</b>	<b>CO2 traffic light with signal tone,</b> wall unit with in-wall power supply unit	<b>NEW 561</b>
---------------------	--	----------------

<b>RCO2-AS</b>	<b>CO2 traffic light with signal tone,</b> wall unit without power supply unit	<b>NEW 561</b>
----------------	---	----------------

<b>RCO2-SD</b>	Room CO2 sensor	<b>565</b>
----------------	-----------------	------------

<b>RCO2-W</b>	Room CO2 sensor	<b>* 565</b>
---------------	-----------------	--------------

<b>RCO2-W-A</b>	Room CO2 sensor with LED display	<b>* 565</b>
-----------------	----------------------------------	--------------

<b>RTM-CO2-SD</b>	Room temperature / CO2 sensor	<b>569</b>
-------------------	-------------------------------	------------

<b>RFTM-CO2-W</b>	Room humidity / temperature / CO2 sensor	<b>* 569</b>
-------------------	--	--------------

<b>AC02-SD</b>	On-wall CO2 sensor	<b>577</b>
----------------	--------------------	------------

<b>AC02-W</b>	On-wall CO2 sensor	<b>* 577</b>
---------------	--------------------	--------------

<b>ATM-CO2-SD</b>	On-wall temperature / CO2 sensor	<b>583</b>
-------------------	----------------------------------	------------

<b>AFTM-CO2-W</b>	On-wall humidity / temperature / CO2 sensor	<b>* 583</b>
-------------------	---	--------------

<b>KCO2-SD</b>	Duct CO2 sensor	<b>593</b>
----------------	-----------------	------------

<b>KCO2-W</b>	Duct CO2 sensor	<b>* 593</b>
---------------	-----------------	--------------

<b>KTM-CO2-SD</b>	Duct temperature / CO2 sensor	<b>599</b>
-------------------	-------------------------------	------------

<b>KFTM-CO2-W</b>	Duct humidity / temperature / CO2 sensor	<b>* 599</b>
-------------------	--	--------------

**Fine dust sensor (PM)**

<b>RPS-SD</b>	Room fine dust sensor	<b>NEW 573</b>
---------------	-----------------------	----------------

<b>RFTM-PS-W</b>	Room humidity / temperature / fine dust sensor	<b>NEW 573</b>
------------------	---	----------------

<b>APS-SD</b>	On-wall fine dust sensor	<b>NEW 585</b>
---------------	--------------------------	----------------

**Multifunctional air quality sensor  
(VOC/CO2/PM)**

<b>RLQ-CO2-W</b>	Room air quality CO2 sensor	<b>* 569</b>
------------------	-----------------------------	--------------

<b>RFTM-LQ-CO2-W</b>	Room humidity / temperature / air quality / CO2 sensor	<b>* 569</b>
----------------------	---	--------------

<b>RFTM-PS-CO2-W</b>	Room humidity / temperature / fine dust / CO2 sensor	<b>NEW* 573</b>
----------------------	---	-----------------

<b>ALQ-CO2-W</b>	On-wall air quality / CO2 sensor	<b>* 583</b>
------------------	----------------------------------	--------------

<b>AFTM-LQ-CO2-W</b>	On-wall humidity / temperature / air quality / CO2 sensor	<b>* 583</b>
----------------------	--	--------------

<b>KLQ-CO2-W</b>	Duct air quality / CO2 sensor	<b>* 599</b>
------------------	-------------------------------	--------------

<b>KFTM-LQ-CO2-W</b>	Duct humidity / temperature / air quality / CO2 sensor	<b>* 599</b>
----------------------	---	--------------

**AIRFLOW MONITORS  
FLOW SENSORS / CONTROLLERS****Airflow monitors**

<b>KLGF</b>	Duct airflow monitor, electronic	<b>601</b>
-------------	----------------------------------	------------

<b>KLSW</b>	Duct airflow monitor, electronic	<b>601</b>
-------------	----------------------------------	------------

<b>SW</b>	Flow monitor, mechanical	<b>605</b>
-----------	--------------------------	------------

TYPE		PAGE
<b>A</b>		
AAVTF	Outdoor humidity sensor	395
ABWF	Outdoor motion detector	539
ABWF/LF	Outdoor motion detector and light sensor	545
ACO2-Modbus	On-wall CO2 sensor	153
ACO2-SD	On-wall CO2 sensor	577
ACO2-W	On-wall CO2 sensor	577
AFF	On-wall humidity sensor	382
AFF-20	On-wall humidity sensor	385
AFF-25	On-wall humidity sensor, pluggable	383
AFF-SD	On-wall humidity sensor	377
AFTF	On-wall humidity / temperature sensor	382
AFTF-20	On-wall humidity / temperature sensor	385
AFTF-20-VA	On-wall humidity / temperature sensor in stainless steel housing	391
AFTF-25	On-wall humidity / temperature sensor, pluggable	383
AFTF-HK-FSE	Outdoor radio sensor for humidity, temperature and light intensity	632
AFTF-EtherCATP	On-wall humidity / temperature sensor	<b>NEW</b> 047
AFTF-Modbus-T3	On-wall humidity / temperature sensor	115
AFTF-SD	On-wall humidity / temperature sensor	377
AFTM-CO2-Modbus	On-wall humidity / temperature / CO2 sensor	153
AFTM-CO2-W	On-wall humidity / temperature / CO2 sensor	583
AFTM-LQ-CO2-Modbus	On-wall humidity / temperature / Air quality / CO2 sensor	153
AFTM-LQ-CO2-W	On-wall humidity / temperature / air quality / CO2 sensor	583
AHKF	Outdoor light intensity sensor	535
AH-40	On-wall hygostat, one-step	435
AHT-30	On-wall hygrothermostat, two-step	439
ALD	Measuring transducer for atmospheric pressure	517
ALQ-CO2-Modbus	On-wall air quality / CO2 sensor	153
ALQ-CO2-W	On-wall air quality / CO2 sensor	583
ALTF 1	Surface-contact temperature sensor	242
ALTF 02	Surface-contact temperature sensor	244
ALTF 2	Surface-contact temperature sensor	245
ALTM 1	Surface-contact temperature measuring transducer	303
ALTM 1-Modbus-T3	Surface-contact temperature measuring transducer	103
ALTM 2	Surface-contact temperature measuring transducer	307
ALTM 2-EtherCATP	Surface-contact temperature measuring transducer	<b>NEW</b> 051
ALTM 2-Modbus-T3	Surface-contact temperature measuring transducer	105
ALTM 2-VA	Surface-contact temperature measuring transducer in stainless steel housing	311
ALTR 060	Surface-contact thermostats	344
ALTR 090	Surface-contact thermostats	344
ALTR 1	Surface-contact thermostats	345
ALTR 3	Surface-contact thermostats	345
ALTR 5	Surface-contact thermostats	345
ALTR 7	Surface-contact thermostats	345
APS-SD	On-wall fine dust sensor	<b>NEW</b> 585
ATF 01	On-wall temperature sensor	186
ATF 1	On-wall temperature sensor	187

TYPE		PAGE
ATF 2	On-wall temperature sensor	189
ATM 2	On-wall temperature measuring transducer	259
ATM 2-EtherCATP	On-wall temperature measuring transducer	<b>NEW</b> 031
ATM 2-Modbus-T3	On-wall temperature measuring transducer	093
ATM 2-VA	On-wall temperature measuring transducer in stainless steel housing	263
ATM-CO2-SD	On-wall temperature / CO2 sensor	583
AWFS-HK-FSE	Outdoor radio sensor for wind strength and light intensity	633
<b>D</b>		
DBWF	In-ceiling motion detector	541
DBWF-C	In-ceiling motion detector	541
DBWF/LF/FTF	In-ceiling motion detector / light / temperature / humidity sensor	547
DFF	In-ceiling humidity sensor	373
DFTF	In-ceiling humidity sensor	373
DHKF	In-ceiling light intensity sensor	537
DTF	In-ceiling temperature sensor	185
DS 1	Differential pressure switch	521
DS 2	Differential pressure switch	521
<b>E</b>		
ETF 6	Screw-in sensor	218
ETF 7	Screw-in sensor	207
ETR	Built-in temperature controller	335
<b>F</b>		
FK 1-FSE	Door/window contact	621
FS-20	2-phase frost protection thermostat	357
FSCO2	In-wall CO2 sensor	575
FSFM	In-wall humidity sensor	369
FSFTM	In-wall humidity / temperature sensor	369
FSFTM-CO2-Modbus	In-wall humidity / temperature / CO2 sensor	149
FSFTM-Modbus	In-wall humidity / temperature sensor	113
FST	Frost protection thermostat, mechanical	349
FST-K	Duct frost protection thermostat, mechanical	353
FSTF	In-wall temperature sensor	178
FSTF-xx	Room control units, in-wall	180
FSTM	In-wall temperature sensor	255
FSTM-CO2	In-wall temperature / CO2 sensor	575
<b>G</b>		
GW-RS485-FEM	Gateway for RS485-Bus	622
<b>H</b>		
HFTM	Sleeve sensor with measuring transducer	297
HFTM-EtherCATP	Sleeve sensor with measuring transducer	<b>NEW</b> 041
HFTM-Modbus-T3	Sleeve sensor with measuring transducer	101
HFTM-VA	Sleeve sensor with measuring transducer in stainless steel housing	301
HSM	Top hat rail measuring transducer	317
HT4-FSE	Hand-held remote control unit	620
HTF-50	Sleeve temperature sensor	236
HTF-200	Sleeve temperature sensor, duct / immersion / screw-in sensor with cable	238
<b>I</b>		
IN 400-FSE-UP	Pushbutton interface, in-wall	628
<b>J</b>		
JA 100-FEM-UP	Venetian blind actuator, in-wall	623
JA 200-FEM-AP	Venetian blind actuator, on-wall	
<b>K</b>		
KA2-Modbus	Communication adapter	161
KAVTF	Duct humidity sensor	413





TYPE		PAGE
KA2-Modbus	Communication adapter	161
KAVTF	Duct humidity sensor	413
KCO2-Modbus	Duct CO2 sensor	157
KCO2-SD	Duct CO2 sensor	593
KCO2-W	Duct CO2 sensor	593
KFF	Duct humidity sensor	401
KFF-20	Duct humidity sensor	403
KFF-SD	Duct humidity sensor	400
KFTF	Duct humidity / temperature sensor	401
KFTF-20	Duct humidity / temperature sensor	403
KFTF-20-VA	Duct humidity / temperature sensor in stainless steel housing	409
KFTF-EtherCATP	Duct humidity / temperature sensor	<b>NEW</b> 051
KFTF-Modbus-T3	Duct humidity / temperature sensor	117
KFTF-SD	Duct humidity sensor	400
KFTM-CO2-Modbus	Duct humidity / temperature / CO2 sensor	157
KFTM-CO2-W	Duct humidity / temperature / CO2 sensor	599
KFTM-LQ-CO2-Modbus	Duct humidity / temperature / air quality / CO2 sensor	157
KFTM-LQ-CO2-W	Duct humidity / temperature / air quality / CO2 sensor	599
KH-10	Duct hygostat, one-step	441
KH-40	Duct hygostat, one-step	443
KHT-30	Duct hygrothermostat, two-step	447
KLGF	Duct airflow monitor	601
KLSW	Duct airflow monitor	601
KLQ-CO2-Modbus	Duct air quality / CO2 sensor	157
KLQ-CO2-W	Duct air quality / CO2 sensor	599
KLQ-SD	Duct air quality sensor	589
KLQ-W	Duct air quality sensor	589
KTM-CO2-SD	Duct temperature / CO2 sensor	599
KTR	Duct temperature controller	341
KW	Condensation control switch	451
KW-SD	Condensation control switch	450
<b>L</b>		
LA-Modbus	Line termination device	159
LS	Leakage sensor	457
<b>M</b>		
MWTF	Mean-value temperature sensor	205
MWTF-SD	Mean-value temperature sensor	205
MWTM	Mean-value temperature measuring transducer	273
MWTM-SD	Mean-value temperature measuring transducer	273
MWTM-EtherCATP	Mean value temperature sensor	<b>NEW</b> 039
MWTM-Modbus-T3	Mean-value temperature sensor	099
<b>O</b>		
OFTF	Surface temperature sensor	241
<b>P</b>		
powerIO®	Installation system for building automation	<b>NEW</b> 067
PREMASGARD® 111x	Pressure measuring transducer, compact design	473
PREMASGARD® 112x	Pressure measuring transducer, compact design	473
PREMASGARD® 112x-SD	Pressure measuring transducer, compact design	472
PREMASGARD® 211x	Pressure measuring transducer, compact design	467
PREMASGARD® 212x	Pressure measuring transducer, compact design	467
PREMASGARD® 212x-SD	Pressure measuring transducer, compact design	466
PREMASGARD® 232x-Modbus-T3	Pressure measuring transducer	129

TYPE		PAGE
PREMASGARD® 612x-EtherCATP	Pressure measuring transducer (Differential pressure, volume flow)	<b>NEW</b> 055
PREMASGARD® 711x	Pressure measuring transducer	479
PREMASGARD® 711x-VA	Pressure measuring transducer in stainless steel housing	485
PREMASGARD® 714x-Modbus	Pressure measuring transducer (Differential pressure, volume flow)	<b>NEW</b> 133
PREMASGARD® 722x	Pressure measuring transducer (Differential pressure) with dual pressure sensor	<b>NEW</b> 491
PREMASGARD® 724x-Modbus	Pressure measuring transducer (Differential pressure, volume flow) with dual pressure sensor	<b>NEW</b> 139
PREMASREG® 711x	Pressure measuring transducer / switch	497
PREMASREG® 711x-VA	Pressure measuring transducer / switch in stainless steel housing	503
PREMASREG® 716x	Volume flow sensor, Pressure measuring transducer / switch	509
PREMASREG® 716x-VA	Volume flow sensor, Pressure measuring transducer / switch in stainless steel housing	515
PREMASGARD® 814x-Modbus	Duct humidity / temperature sensor with pressure measuring transducer	143
<b>R</b>		
RBWF	Room motion detector	538
RBWF/LF	Room motion and light detector	543
RCO2-AS NT ST	CO2 traffic light with signal tone, table-top unit with plug-in power supply unit, stainless steel stand	<b>NEW</b> 561
RCO2-AS NT	CO2 traffic light with signal tone, wall unit with plug-in power supply unit	<b>NEW</b> 561
RCO2-AS UPNT	CO2 traffic light with signal tone, wall unit with in-wall power supply unit	<b>NEW</b> 561
RCO2-AS	CO2 traffic light with signal tone, wall unit without power supply unit	<b>NEW</b> 561
RCO2-Modbus	Room CO2 sensor	147
RCO2-SD	Room CO2 sensor	565
RCO2-W	Room CO2 sensor	565
RCO2-W-A	Room CO2 sensor with LED display	565
RFF	Room humidity sensor	367
RFTF	Room humidity sensor	367
RFTF-Modbus	Room humidity / temperature sensor	111
RFTF-Modbus-xx	Room control units	089
RFTF2-FSE	Room humidity / temperature / radio sensor	614
RFTF2-FSE-P	Room humidity / temperature / radio sensor	615
RFTF2-FSE-PD	Room humidity / temperature / radio sensor	617
RFTF2-FSE-PT	Room humidity / temperature / radio sensor	616
RFTM-BW-FSE	Room humidity / temperature / motion radio sensor	613
RFTM-CO2-Modbus	Room humidity / temperature / CO2 sensor	147
RFTM-CO2-W	Room humidity / temperature / CO2 sensor	569
RFTM-FSE	Room humidity / temperature / radio sensor	613
RFTM-FSE-ST	Room control unit / Room humidity / temperature / radio sensor	613
RFTM-LQ-CO2-Modbus	Room humidity / temperature / air quality / CO2 sensor	147
RFTM-LQ-PS-CO2 Modbus	Room humidity / temperature / air quality / fine dust / CO2 sensor	<b>NEW</b> 147

TYPE		PAGE
RFTM-LQ-CO2-W	Room humidity / temperature / air quality / CO2 sensor	569
RFTM-LQ-FSE	Room humidity / temperature / VOC radio sensor	613
RFTM-PS-CO2-W	Room humidity / temperature / fine dust / CO2 sensor	<b>NEW</b> 573
RFTM-PS-W	Room humidity / temperature / fine dust sensor	<b>NEW</b> 573
RGTF 1	Smoke gas temperature sensor	225
RGTF 2	Smoke gas temperature sensor	231
RGTM 1	Smoke gas temperature measuring transducer	285
RGTM 2	Smoke gas temperature measuring transducer	291
RH-2	Room hygrostat, one-step	429
RHKF	Room light intensity sensor	534
RHT	Room hygrothermostat	428
RHT-30	Room hygrothermostat, two-step	433
RLQ-CO2-Modbus	Room air quality CO2 sensor	147
RLQ-CO2-W	Room air quality CO2 sensor	569
RLQ-SD	Room air quality sensor	557
RLQ-W	Room air quality sensor	557
RPPF	Room pendulum humidity sensor	419
RPPF-25	Room pendulum humidity sensor, pluggable	423
RPPF-SD	Room pendulum humidity sensor	415
RPPTF	Room pendulum humidity / temperature sensor	419
RPPTF-25	Room pendulum humidity / temperature sensor, pluggable	423
RPPTF-Modbus-T3	Room pendulum humidity / temperature sensor	119
RPS-SD	Room fine dust sensor	<b>NEW</b> 573
RPTF 1	Room pendulum temperature sensor	246
RPTF 2	Room pendulum temperature sensor	247
RPTM 1	Room pendulum temperature measuring transducer	313
RPTM 1-Modbus-T3	Room pendulum temperature sensor	107
RPTM 2	Room pendulum temperature measuring transducer	315
RPTM 2-Modbus-T3	Room pendulum temperature sensor	109
RSTF	Room radiation temperature sensor	249
RTF	Room temperature sensor	166
RTF-xx	Room control units	171
RTF 2-FSE	Room temperature radio sensor	614
RTF 2-FSE-P	Room temperature radio sensor	615
RTF 2-FSE-PD	Room temperature radio sensor	617
RTF 2-FSE-PDT	Room temperature radio sensor	618
RTF 2-FSE-PT	Room temperature radio sensor	616
RTM 1	Room temperature measuring transducer	253
RTM 1-Modbus	Room control units	091
RTM-CO2-SD	Room temperature CO2 sensor	569
RTR-B	Room temperature controller	321
RTR-S	Room temperature controller, fan coil controller	323
RTR-E-UP	Room temperature controller, clock thermostat	327
RYMASKON® 200	Room control units for room automation	087
RYMASKON® 400	Room control units for room automation	085
RYMASKON® 500	Room control units (Thermostat)	<b>NEW</b> 083
RYMASKON® 600	Room control units (Controller)	<b>NEW</b> 079
RYMASKON® 700	Room control units (Interface)	<b>NEW</b> 075
<b>S</b>		
SA 100-FEM-UP	Switching actuator, in-wall	624
SA 200-FEM-UP	Switching actuator, in-wall	625
SA 400-FEM-AP	Switching actuator, on-wall	630
SHD	Pressure measuring transducer	523
SHD-SD	Pressure measuring transducer	523
SHD 400	Differential pressure transmitter	525
SHD 692	Differential pressure transmitter	527

TYPE		PAGE
SV 600-FEM-AP	Dimming actuator, on-wall	631
SW	Flow monitor	605
<b>T</b>		
TA 100-FEM-UP	Thermostat actuator, in-wall	626
TA 200-FEM-UP	Thermostat actuator, in-wall	627
TET	Top hat rail measuring transducer	359
TF 43	Duct / immersion / screw-in sensor	194
TF 43-F	Duct / immersion / screw-in sensor with cable	199
TF 54	Duct / immersion / screw-in sensor	210
TF 65	Duct / immersion / screw-in sensor	192
TF 65-F	Duct / immersion / screw-in sensor with cable	199
TM 54	Duct / immersion / screw-in sensor	277
TM 43	Duct / immersion / screw-in sensor	267
TM 65	Duct / immersion / screw-in sensor	267
TM 65-EtherCATP	Duct / immersion / screw-in sensor	<b>NEW</b> 033
TM 65-Modbus-T3	Duct / immersion / screw-in sensor	095
TR 22	Temperature controller	329
TR 040	Temperature controller	328
TR 04040	Temperature controller, two-step	330
TR 060	Temperature controller	328
TR xx-F	Temperature controller with remote sensor	331
TW	Dew point control switch	455
TW-Modbus-T3	Dew point control switch	125
<b>U</b>		
USB-FEM	USB communication stick (radio program)	611
<b>V</b>		
VFF	Showcase humidity sensor	427
VFTF	Showcase humidity / temperature sensor	427
VFTF-Modbus-T3	Showcase humidity / temperature sensor	121
<b>W</b>		
WFS	Wind vane switch	603
WT-FSE	Wall pushbutton	619
<b>Accessories</b>		
ASD-06	Connection set	647
ASD-07	Connection nipple (90°)	647
ASS-UV	Connecting hose, UV-resistant	647
DAL	Pressure outlet	647
DS-MW	Mounting bracket, sheet steel	647
ESSH	Welding protection sleeve	646
HS-Adapter	Universal bracket (top-hat rails)	649
KRD-04	Capillary tube leadthrough, plastic	644
MF-xx-K	Mounting flanges, plastic	644
MF-xx-M	Mounting flanges, metal	645
MFT-20-K	Mounting flanges, plastic	644
MK-xx	Mounting clamps	645
Modbus-Y	Y-adapter for cable gland	649
SF-xx	Sinter filter, replaceable	649
TH-Adapter-HW	Immersion sleeve adapter	646
TH 08	Immersion sleeves	636
TH	Immersion sleeves	638
THE	Immersion sleeves	642
THR	Immersion sleeves	640
PSW-09	Stainless steel paddle	649
PWFS-08	Stainless steel vane (WFS)	649
WLP-1	Heat-conductive paste, silicone-free	649
WS-xx	Protection hoods, stainless steel	648
<b>BASIC</b>	Preference programme	<b>662 - 669</b>





# S+S Goes Digital

USE OUR ONLINE RESOURCES  
FOR PLANNING AND SOURCING

## BIM READY

Building Information Modeling (BIM) is the key to efficient planning, approval, maintenance and further development of operation-critical building systems. Our products are BIM ready and can be directly integrated in your BIM process. With detailed data for all devices and in standardised formats to create a precise digital image in your BIM system.



### Benefits for architects, project designers, building contractors and owners:

- + Transparent planning and projecting
- + Speedy approvals, installation and commissioning
- + Fewer input errors
- + Efficient maintenance
- + Easy changes
- + Flexible extensions

24h

24-hours  
shipment



**DIRECT ONLINE ORDERING**

[www.SplusS.de/shop](http://www.SplusS.de/shop)

For your convenience, you can order all items in our catalogue directly in our new web shop – 24/7 and with guaranteed shipment on working days within 24 hours.

# RYMASKON®

## ROOM OPERATING DEVICES FOR SINGLE-ROOM CONTROL - THE FAMILY IS GROWING

In addition to the previous RYMASKON® Series 200 and 400, there are now three further innovative product lines available for room air conditioning.

The new RYMASKON® Series 500 (Thermostat), 600 (Controller) and 700 (Interface) are characterized by their versatile configuration and deployment possibilities. They have a particular fit in networked applications and energy management systems according to ISO 50001 for efficient cross-facility room climate control. Typical applications are heating and cooling systems, including cooling ceilings and floor heating, as well as fan coil units.

A **colour touch display** with international icons enables on-site settings as needed. The user-friendly interface in a flat, stylish housing blends well with any interior design.

Details on pp. 072

RYMASKON® 500 display icons



Room  
**20**<sup>°C</sup><sub>.1</sub>  
Room temperature  
[°C]

Outside  
**10**<sup>°C</sup><sub>.5</sub>  
External temperature  
[°C]

Humidity  
**45**<sup>%RH</sup>  
Relative humidity  
[%RH]

Air Conditioning  
[AC]

Sun protection  
(1 zone)

**NEW**

### RYMASKON® 500 Thermostat

The thermostat controls a **heating or cooling valve** directly by relay.

**Sun protection** (blinds, shutters) can be controlled in one zone by bus.

In addition to the integrated sensor, the device can be connected to **two external temperature sensors** (NTC10K).







S+S REGELTECHNIK

NEW



### RYMASKON® 600 Controller

The controller provides analogue outputs (0...10 V) for closed-loop control of up to two heating or cooling valves as well as 6-way valves and ventilation (EC fan).

Sun protection (blinds, shutters) can be controlled in two zones by bus.

### RYMASKON® 700 Interface

The interface provides control of heating or cooling valves, fan speed as well as sun protection (blinds, shutters) in two zones by bus.

In addition to the integrated sensors, the device can be connected to two external temperature sensors (NTC10K).

## FEATURES

- > Control of heating and cooling valves, including 6-way valves
- > Control of ventilation (EC fan) or air conditioning
- > Sun protection control (blinds, shutters) in up to two zones
- > Integrated sensors for temperature, humidity and CO2 (optional)
- > Connection for up to two external temperature sensors (NTC10K)
- > RS485 interface for Modbus RTU or BACnet
- > Different control channel configurations and further device variants
- > Stylish and flat white housing for installation on standard flush-mounting sockets
- > 3,5" touch display (approx. 50 x 75mm, 255,000 colours, 320 x 480 pixel resolution) with back-lighting
- > Graphic user interface with intuitive icons
- > Configuration tool for convenient setting and transfer of the operating and functional parameters

RYMASKON® 600/700 display icons

RYMASKON® 600/700 with CO2 sensor

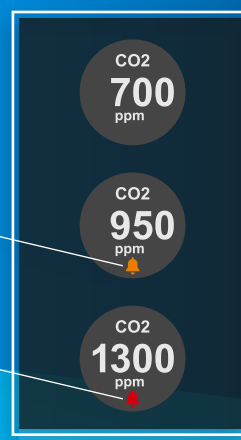
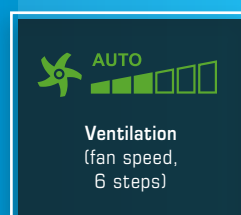
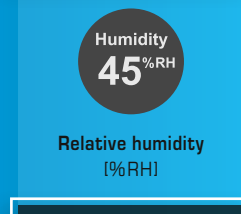
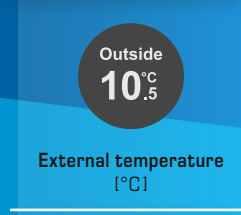

RYMASKON® 600 Alarm levels 1/2 (incl. bell icon) configurable





**NEW**

## SYSTEM FOR FACILITY AUTOMATION 4.0 DECENTRAL. SIMPLE. ADVANCED.

The **powerIO**<sup>®</sup> system is a perfect solution for integrating sensors and actuators. It combines power and data and enables a completely decentralised facility installation design.

Instead of routing kilometres of cables from central cabinets to all sensors and actuators in a star topology with subsequent wiring of each individual connection, as in the past, the **powerIO**<sup>®</sup> system simplifies installation and minimises your time consumption, while at the same time offering more possibilities.

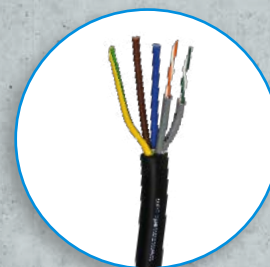

### powerIO<sup>®</sup>-Line

Hybrid cable for data transmission (Ethernet TCP/IP, 100 Mbit/s) and power (230 V)

## COST-EFFECTIVE

Reduction of cabling and cabinets by up to 70 %

- Fewer cables and up to 30 % lower installation costs
- High time savings thanks to less coordination and reduced construction times
- Reduced copper and PVC consumption, and lower M&C costs

## FLEXIBLE

Open system for easy and fast expansion

- Freedom of implementation thanks to standardised protocols and free choice of control system
- Modular and decentral design for virtually any topology

## DEPENDABLE

Better control, higher safety, fewer connection faults, more data

- Greater safety: significant reduction of fire load
- Better control: fewer connection faults
- High data traffic at faster transmission speeds



### TCP-protocols

Free choice of DDC/PLC

[www.powerio.com](http://www.powerio.com)



Take a look at our 3D demo wall and see for yourself!

[www.powerio.com/demowall](http://www.powerio.com/demowall)





S+S REGELTECHNIK

**powerIO®-Box**

Decentral automation box,  
serial-to-TCP conversion



**4x RS485**

M12 5-pin plug connections  
with 24V voltage supply and bus



**Ventilation technology**

**powerIO®-App**

[www.powerio.com/app](http://www.powerio.com/app)



**Single-room control**



**Control in compliance with IEC 61131-3**

Optionally convert any powerIO®-Box  
into a CODESYS® control.

**powerIO®** is the system for  
decentralised facility automation.  
**Details on pp. 066**





## Automated Sensor Technology

S+S TEMPERATURE, HUMIDITY AND PRESSURE TRANSDUCERS FOR OPERATION ON THE ETHERCAT P INDUSTRIAL BUS

We have extended our bus-capable portfolio to include a range of sensor devices for consistent industrial automation solutions from field to control level using EtherCAT P. The 'P' stands for routing both real-time communication and power through one and the same cable. Standardised M8 connectors enable commissioning without the need for opening the device.

Our EtherCAT P capable products are perfectly tailored to cabinet-free automation in industrial process, plant and facility engineering. They are ideal for use in central energy management as well as for interconnected temperature, humidity and pressure control in poorly accessible areas.

Moreover, they offer superior added-value characteristics for configuration, data processing and display. All devices can also communicate using wireless Bluetooth technology. **Details on pp. 026**



3 status LEDs show data flow and bus activity.

Single-cable solution for communication and power with standardised M8 connectors





**NEW**

Bar graph display for indication of working, limiting or fault ranges. Colour change and colour gradients of the 7 LEDs can be configured.

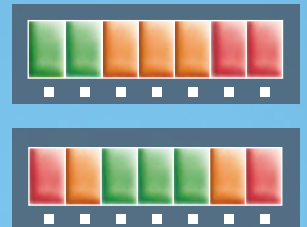

**THERMASGARD®  
ALTM2-EtherCATP**  
Surface-contact  
temperature transducer



**HYGRASGARD®  
KFTF-EtherCATP**  
Duct temperature and  
humidity transducer



**HYGRASGARD®  
AFTF-EtherCATP**  
On-wall temperature and  
humidity transducer



**PREMASGARD®  
612x-EtherCATP**  
Differential pressure  
transducer

## S+S ADDED VALUE

- **Wireless communication option**  
Bluetooth-capable devices
- **Writable LCD display**  
large back-lit three-line display,  
individually programmable
- **Configurable LED display**  
individually configurable bar graph with  
7 colour LEDs (e.g. as traffic light indicator)
- **Additional configuration possibilities**  
preset of process data objects (PDOs)  
to the controller using the ESI function  
module for measured value queries, filtering,  
sampling time, etc.
- **Extended sensor data**  
e.g. retrievable history (min/max/mean)  
and service interval determination depending  
on stress and sensor type

## ADVANTAGES AT A GLANCE

- **Single-cable solution with free choice of topology**  
communication and power on one single cable,  
for combination with line, star and tree structures
- **Implicit EtherCAT bus configuration and diagnosis**  
straightforward integration at PLC level using  
the EtherCAT Slave Information (ESI) configuration  
file of the device, and communication fault counter  
for quick localization of connection problems
- **Fast standard industrial bus (Industry 4.0)**  
intelligent machine-to-machine communication
- **Standardised M8 connector**  
minimal wiring thanks to safe  
and quick plug-screw connections



**NEW**



## 32 Devices in One

### ACTIVE PRESSURE TRANSMITTER WITH DOUBLE SENSOR AND AUTOMATIC OUTPUT SWITCHING

Our new calibratable **PREMAGARD® 722x double-sensor** pressure transmitter is a real multi-functional talent and therefore ideal for use in clean room, medical and filtration engineering, ventilation and air conditioning ducts, spray booths and commercial kitchens, level measurement and frequency converter control.

With 2x 8 switchable measuring ranges (max.  $\pm 500$  Pa or  $\pm 7000$  Pa) as well as automatic output detection and switching to the required 0...10V or 4...20 mA standard signal, it masters the tasks of up to 32 individual pressure sensors.

In this way, even highly demanding filtration and ventilation systems can be monitored with just one single pressure transmitter.

**Details on pp. 486**

Tyr 2 housing, optionally with/without display and cable gland or M12 connector

#### WITH DOUBLE PRESSURE SENSOR

#### PREMAGARD® 722x (active)

The actual pressure is alternately displayed (approx. 6 s interval), the measuring channel indicated at lower left



Pressure (channel 1)



Pressure (channel 2)

**NEW**

The newly developed **Automatic Output Switching** process is a protected S+S patent. (No. DE 10 2015 015 941 B4)

Automatic Detection and Switching to 0...10V or 4...20 mA standard signal



**AOS-PATENTED**

**AUTOMATIC OUTPUT SWITCHING**





S+S REGELTECHNIK



# The Automation Specialist

## BUS-CAPABLE DEVICE WITH DOUBLE SENSOR FOR PRESSURE, DIFFERENTIAL PRESSURE, VOLUME FLOW AND TEMPERATURE

The new maintenance-free **PREMASGARD® 724x-Modbus** **double-pressure sensor** unit can be used in many different application areas. The focus is on precise measuring and monitoring of positive, negative and differential pressures in two measuring channels using one single device (max. pressure ranges ±500 Pa and ±7000 Pa).

There is a version available for optional connection of an Pt1000 external sensor, if additional temperature reading is required (max. measuring range -50...+150 °C).

The highlights of the Modbus device also include its galvanically isolated RS485 interface as well as the possibility of setting bus parameters and bus address when the unit is de-energised.

Details on pp. 134



The 'T' version features an analogue input for connecting a Pt1000 external temperature sensor.

Tyr2 housing, optionally with/without display and cable gland or M12 connector

**NEW**

### WITH DOUBLE PRESSURE SENSOR

#### PREMASGARD® 724x-Modbus

As with all of our networkable devices, the display is individually configurable by bus.



**NEW!** The display can be switched by bus from **SI units** (Pa, m³/h, °C) to **imperial units** (inWC, CFM, °F).



Pressure (channel 1)



Pressure (channel 2)



Volume flow



Temperature (type 'T')



The **AERASGARD® RFTM-PS** active measuring transducer displays the measured value as well as the switch point status.



The **AERASGARD® RFTM-LQ-PS-CO2-Modbus** has an individually programmable display.

**NEW**



New, for on-wall installation: **AERASGARD® APS-SD** available in Tyr2 housing.

## Against Fine Dust in Room Air

### AERASGARD® ROOM CLIMATE MEASURING TRANSDUCERS WITH CONTAMINATION RESISTANT LASER SENSOR

The extended range of our **AERASGARD®** devices is now also capable of measuring hazardous fine dust or particulate matter, i.e. aerosols with particle sizes from 2.5 to 10 µm.

The fine dust load in the room air is measured by a highly contamination resistant laser sensor and displayed or read out in µg/m³.

The fine dust measuring transducers have been designed as room devices and are available in various configurations, from the basic version without display to multifunctional models for several measurands.

Our **AERASGARD®** room devices is available for up to five measurands – now also including fine dust (PM).



Temperature



Humidity



Air Quality (VOC)



Carbon dioxide (CO2)



Fine dust (PM)

On the bottom line, the **entire room climate** can be effectively monitored and controlled **with one single device**.  
**Details on pp. 144 / 570 / 584**

**NEW**





S+S REGELTECHNIK

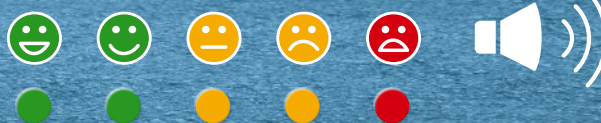

**NEW**

# CO2 Traffic Light with Acoustic Signal

## AERASGARD® CO2 MEASURING DEVICES FOR PROPER ANTI-INFECTION VENTILATION IN SCHOOLS

A lot of breathing occurs where people meet in rooms. Next to the CO2 concentration in the room air, this also increases the number of aerosols which can carry pathogens, such as the coronavirus. The CO2 load is therefore considered an indicator for timely intermittent ventilation as an effective means of preventing infections.

To this end, we have extended the range of our proven CO2 measuring devices with the **AERASGARD® RCO2-AS**. Equipped with an optical NDIR sensor (non-dispersive infrared technology), it measures the CO2 content in the room air from 0 to 3000 ppm, and displays the result with traffic light LEDs in graded light intensity. An additional signal tone sounds when the warning levels are reached.

≥ 1000 ppm = yellow range  
≥ 2000 ppm = red range

Five colour LEDs indicate the current need for room ventilation **at a glance**.  
**Details on pp. 558**

For wall mounting:

**AERASGARD® RCO2-AS NT**  
with plug-in power supply unit,

**AERASGARD® RCO2-AS**  
without power supply unit  
(not shown)

**AERASGARD® RCO2-AS UPNT**  
with in-wall flush-mount  
power supply unit



Mobile desktop device:  
**AERASGARD® RCO2-AS NT ST**  
with plug-in power supply unit  
and stainless steel stand



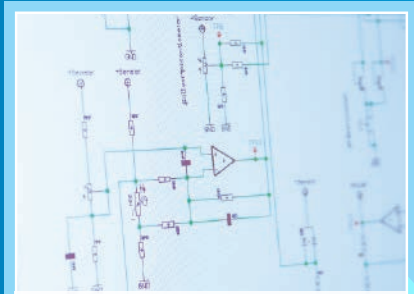

**Hard- & Software**



**Test Equipment**



**MADE  
IN  
GERMANY**



**Production**



**Testing**



**Shipping**





S+S REGELTECHNIK

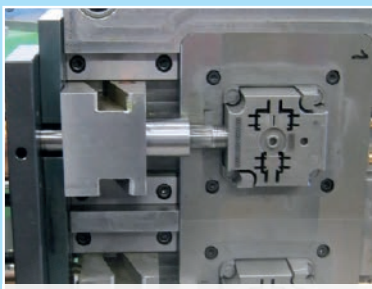

Toolmaking

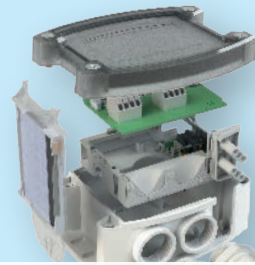

Construction



Design



- approx. 80 employees
- 4000 m<sup>2</sup> of production space, incl. test centre, warehousing and shipping area

■ 2000 m<sup>2</sup> of office space for development, marketing, sales and administration

- 24 hours shipping service
- Made-to-order manufacturing

## Everything from a Single Source

S+S stands for a fully integral value chain. All products are designed, developed, manufactured and programmed in-house. Our new gigafactory in Nuremberg also includes a test centre with climate chambers, measuring benches and calibration facilities for all measurands.



# Catalogue Items 2022







### ETHERCAT P

Bus-capable sensors for industrial automation

026 - 055



### MODBUS & BACnet

Single-room controllers with touch screen, bus-capable sensors with programmable control

056 - 161



### THERMASGARD® & THERMASREG®

Temperature sensors/temperature transducers, temperature controllers and thermostats

162 - 359



### HYGRASGARD® & HYGRASREG®

Humidity sensors/humidity transducers, humidity controllers and hygrometers

360 - 457



### PREMASGARD® & PREMASREG®

Pressure sensors/pressure transducers, pressure regulators and switches

458 - 527

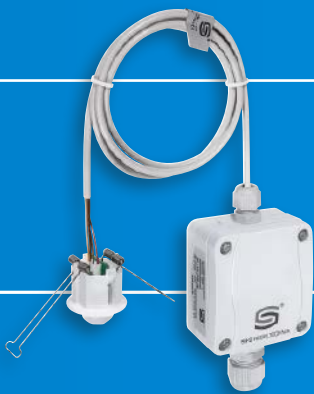

### PHOTASGARD® & KINASGARD®

Light intensity sensors, motion detectors and presence detectors

528 - 547



### AERASGARD® RHEASGARD® & RHEASREG®

Air quality, CO<sub>2</sub> and fine dust sensors, flow monitors and controllers

548 - 605



### KYMASGARD®

Radio sensors, radio transmitters and radio signal receivers with EnOcean technology

606 - 633



### Immersion sleeves & Accessories

Basic Programme, appendix, useful information

634 - 675





## EtherCAT P

Industrial automation requires fast and integrated solutions for real-time communication from control to field level.

With our EtherCAT P bus-capable measuring transducers you can meet these higher demands also in the area of sensor technology.

### APPLICATION RANGE

- > Industrial process and plant automation
- > Central energy management in the manufacturing industry and in process engineering
- > Networked measuring and control of temperature, humidity and pressure parameters in poorly accessible or distant areas





## THERMASGARD<sup>®</sup>, HYGRASGARD<sup>®</sup>, PREMASGARD<sup>®</sup>

026 – 055

### Temperature sensors

<b>ATM 2 - EtherCATP</b>	Outside temperature sensor	NEW 031
<b>TM 65 - EtherCATP</b>	Duct / immersion / screw-in temperature sensor	NEW 033
<b>MWTM - EtherCATP</b>	Mean-value temperature sensor	NEW 039
<b>HFTM - EtherCATP</b>	Sleeve sensor with cable	NEW 041
<b>ALTM 2 - EtherCATP</b>	Surface-contact temperature sensor	NEW 043

### Moisture and temperature sensors

<b>AFTF - EtherCATP</b>	On-wall humidity and temperature sensor	NEW 047
<b>KFTF - EtherCATP</b>	Duct humidity and temperature sensor	NEW 051

### Pressure sensors

<b>PREMASGARD<sup>®</sup> 612x - EtherCATP</b>	Pressure sensor for differential pressure and volume flow	NEW 055
--	---	---------

### Accessories

Special accessories for EtherCATP	NEW 651
For others see chapter Accessories	636



## THERMASGARD<sup>®</sup>, HYGRASGARD<sup>®</sup> & PREMASGARD<sup>®</sup> for industrial automation

### Ultra-fast industrial bus

Our new EtherCAT P sensors are perfectly tailored for automation without switch cabinets in industrial process, system and facility engineering. For central energy management and for networked temperature, humidity and pressure control in areas that are difficult to access.

### Optimum Precision

All devices are developed, manufactured and tested in accordance with the latest criteria. Take advantage of our experience, our development, manufacturing and product know-how and order these products directly from the manufacturer.

### Technical Highlights

- > EtherCAT compatible
- > Can be cascaded in all topologies
- > Dual power supply
- > Minimal amount of wiring due to MB connectors
- > Fewer fault sources

### S+S ADDED VALUE

- > Large, three-line display, individually programmable
- > Configurable bar graph for displaying the measured value
- > Additional configuration facilities, e.g. measurand, filtering, sample time
- > Extended sensor data, e.g. retrievable history, maintenance interval determination

### Certified Quality



Our development and production in Nuremberg/Germany is certified by TÜV Thüringen according to DIN EN ISO 9001:2015.



GOST certified



EAC certified

### Approved Safety



RoHS conforming materials



ESD compliant manufacturing



CE compliance tested by external laboratories



# EtherCAT<sup>®</sup> TP

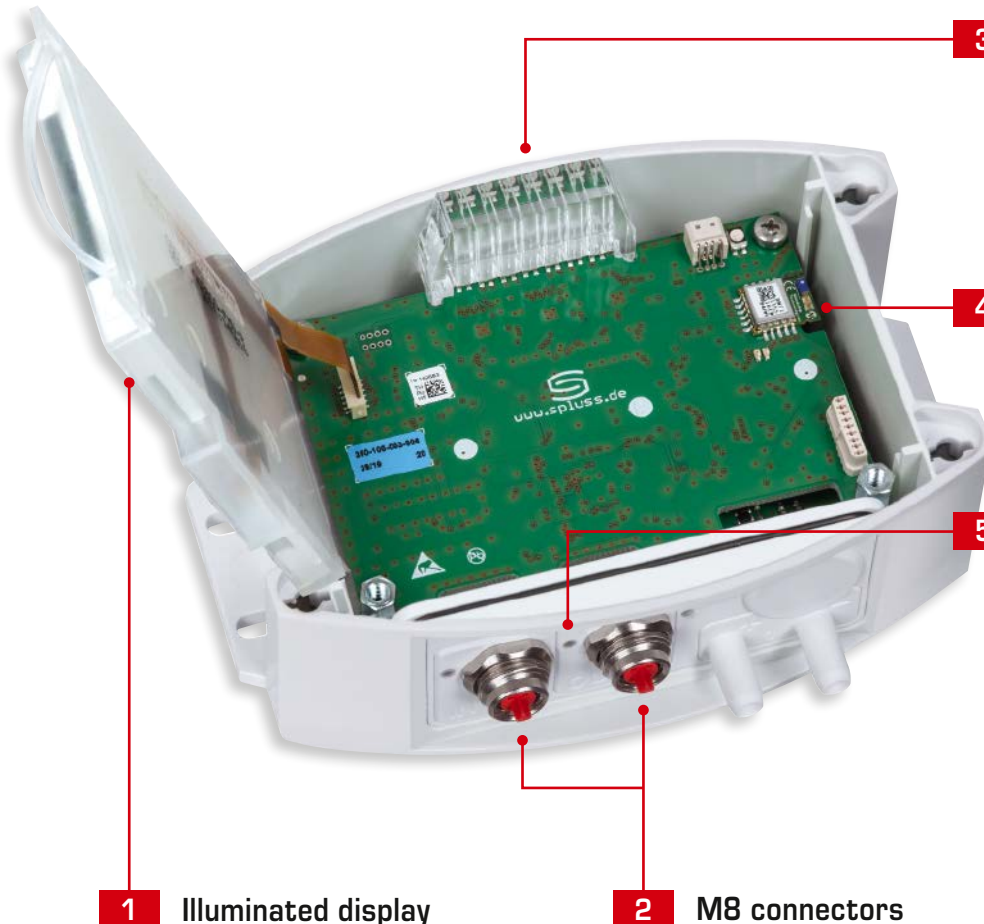

**1 Illuminated display**  
Large, three-line display with background lighting, individually programmable

**2 M8 connectors**  
Low wiring effort due to EtherCAT TP coded built-in connectors

**3 Bargraph**  
Fibre optics with 7 LEDs, colours, colour change or colour gradient freely configurable, e.g. as traffic light display

**4 Bluetooth**   
Module for wireless communication

**5 Status LEDs**  
for displaying the three EtherCAT operating statuses IN, OUT and RUN



S+S TECHNOLOGY FOR  
SMART BUILDINGS

**On-wall / outdoor- / wet room temperature measuring transducers, Bluetooth-enabled, with EtherCATP port**

Networkable outdoor temperature measuring transducer **THERMASGARD® ATM2-EtherCATP** with M8 plug-in connector (EtherCATP-encoded), Bluetooth-enabled, in an impact-resistant plastic housing with quick-locking screws, optionally with /without display and bar graph.

The on-wall sensor is used to detect the temperature in gaseous media. It is used outdoors or in wet rooms, in cold storage buildings and greenhouses, in the industrial sector and in agriculture. Installation on outside walls is preferably performed on the north side or in a protected place. In case of direct solar irradiation, the weather and sun protection hood **WS 03** (accessory) is to be used. The sensor is factory-calibrated.

**EtherCATP-enabled measuring transducer** for industrial requirements with maximum reliability: includes easy PLC integration using the device's ESI configuration file, diagnostics (such as communication failure counter), advanced settings options, access to historical data (min / max) and establishing the sensor's service interval. Optionally with large illuminated display (3-line, customised programming in the 7-segment and dot-matrix range) and bar graph (7-digit, LEDs freely configurable) for graphical display, e.g., as a traffic light indicator.

ATM2-EtherCATP



**EtherCATP**  
Cable connection and LED status display

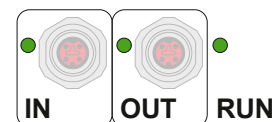

TECHNICAL DATA	
Power supply:	24VDC via EtherCATP (U <sub>S</sub> )
Power consumption:	< 3W
Bus protocol:	<b>EtherCAT</b>
Radio technology:	<b>Bluetooth</b> (LE)
Sensor:	Pt1000, DIN EN 60751, class B ( <b>Perfect Sensor Protection</b> )
Measuring range:	-50...+150°C
Deviation in temperature:	Typically ± 0.2K at +25°C
Medium:	Clean air and non-aggressive, non-combustible gases
Protective tube:	Stainless steel, <b>V4A</b> (1.4571), Ø = 6mm (see dimensional drawing)
Housing:	Plastic, UV-resistant, polyamide material, 30% glass-globe reinforced, with quick-locking screws (slotted / Phillips head combination), colour traffic white (similar to RAL 9016), housing cover for display is transparent!
Dimensions:	126 x 90 x 50mm (Tyr2)
Cable connection:	<b>M8 plug-in connector</b> , EtherCATP-encoded
Ambient temperature:	Measuring transducer -30...+70°C
Permitted humidity:	< 95% r. H., non-precipitating air
Protection class:	III (according to EN 60 730)
Protection type:	<b>IP 54</b> (according to EN 60 529) when built-in
Standards:	CE conformity, according to EMC Directive 2014 / 30 / EU, according to RED 2014 / 53 / EU
Equipment:	<b>Display with illumination</b> , 3-line, customised programming, cutout approx. W 51 x H 29mm, to display the actual temperature or a customised display value. <b>Bar graph</b> , 7-digit, LEDs freely configurable, to graphically display the reading.
<b>ACCESSORIES</b>	See table

EtherCAT P	LED status display
<b>1. LED</b>	<b>"IN"</b>
off	no connection to upstream EtherCAT module
illuminated	LINK: connection to upstream EtherCAT module
blinking	ACT: communication with upstream EtherCAT module
<b>2. LED</b>	<b>"OUT"</b>
off	no connection to downstream EtherCAT module
illuminated	LINK: connection to downstream EtherCAT module
blinking	ACT: communication with downstream EtherCAT module
<b>3. LED</b>	<b>"RUN"</b>
off	EtherCAT module is in "Init" state
quickly blinking	EtherCAT module is in "Pre-Operational" state
slowly blinking	EtherCAT module is in "Safe-Operational" state
illuminated	EtherCAT module is in "Operational" state
<b>The status LEDs are next to the cable connection.</b>	

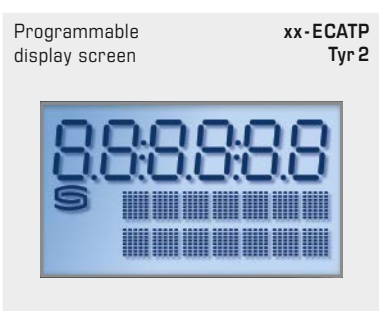
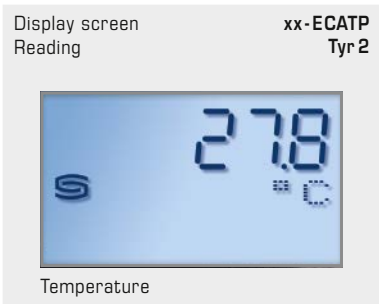





**NEW**

S+S REGELTECHNIK

THERMASGARD® ATM2 - EtherCAT P

On-wall / outdoor- / wet room temperature measuring transducers, Bluetooth-enabled, with EtherCAT port

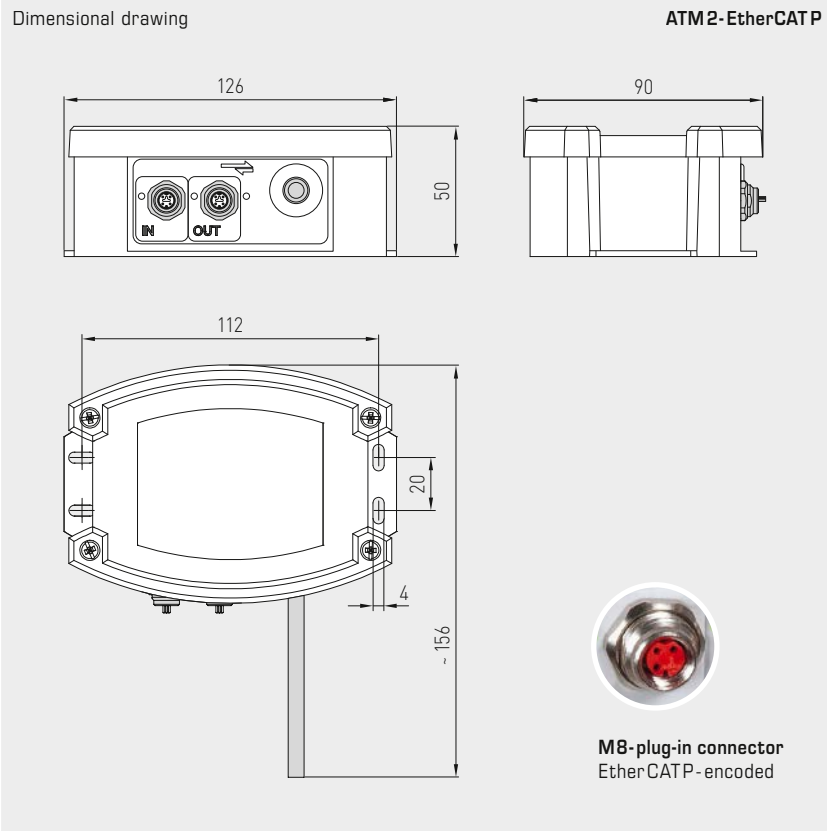

ATM2-EtherCAT P with display and bar graph



**WS-03**

Weather and sun protection hood, (optional)



High-performance encapsulation against vibration, mechanical stress and humidity

**PS-PROTECTION**  
PERFECT SENSOR PROTECTION

THERMASGARD® ATM2 - EtherCAT P		On-wall temperature sensor, with EtherCAT port				
Type / WG02	Measuring Range Temperature	Sensor	Output	Bar graph Display	Item No.	Price
<b>ATM2-ECATP xx</b>						
ATM2-ECATP	-50...+150 °C	Pt1000	EtherCAT P		2001-6201-9100-001	<b>329,38 €</b>
ATM2-ECATP LCD	-50...+150 °C	Pt1000	EtherCAT P	<input type="checkbox"/> <input checked="" type="checkbox"/>	2001-6202-9100-001	<b>373,43 €</b>
<b>Note:</b>	Cable connection with <b>M8 plug-in connector</b> (EtherCAT P-encoded)					

ACCESSORIES		
<b>WS-03</b>	Weather and sun protection hood, 200 x 180 x 150 mm, stainless steel V2A (1.4301)	7100-0040-6000-000 <b>42,61 €</b>

For further information, see last chapter Accessories!



Immersion / screw-in / duct  
temperature measuring transducer, Bluetooth-enabled,  
with EtherCATP port

Networkable temperature measuring transducer with sensor tube THERMASGARD®  
TM65-EtherCATP with M8 plug-in connector (EtherCATP-encoded), Bluetooth-enabled,  
in an impact-resistant plastic housing with quick-locking screws, optionally with /without  
display and bar graph.

The duct sensor is used to detect the temperature in liquid or gaseous media. Use the stainless  
steel immersion sleeves for aggressive media. It is used in heating engineering, ventilation and air  
conditioning ducts, pipes, storage systems, compact district heating stations, warm and cold  
water systems, oil and lubrication cycle systems, machine and systems engineering and the entire  
industry sector. The sensor is factory-calibrated.

**EtherCATP-enabled measuring transducer** for industrial requirements with maximum reliability:  
includes easy PLC integration using the device's ESI configuration file, diagnostics (such as communication  
failure counter), advanced settings options, access to historical data (min / max) and establishing the  
sensor's service interval. Optionally with large illuminated display (3-line, customised programming in  
the 7-segment and dot-matrix range) and bar graph (7-digit, LEDs freely configurable) for graphical  
display, e.g., as a traffic light indicator.

TM65-EtherCATP



EtherCATP  
Cable connection and  
LED status display

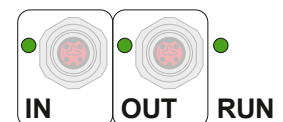

**TECHNICAL DATA**

Power supply:	24VDC via EtherCATP (U <sub>S</sub> )
Power consumption:	< 3W
Bus protocol:	<b>EtherCAT</b>
Radio technology:	<b>Bluetooth</b> (LE)
Sensor:	Pt1000, DIN EN 60751, class B ( <b>Perfect Sensor Protection</b> )
Measuring range:	-50...+150°C
Deviation in temperature:	Typically ±0.2K at +25°C
Medium:	Clean air and non-aggressive, non-combustible gases; liquids depending on selected immersion sleeve (accessory)
Protective tube:	Stainless steel, <b>V4A</b> (1.4571), Ø = 6mm, installation length (IL) = 50-400mm (see table)
Housing:	Plastic, UV-resistant, polyamide material, 30% glass-globe reinforced, with quick-locking screws (slotted / Phillips head combination), colour traffic white (similar to RAL 9016), housing cover for display is transparent!
Dimensions:	126 x 90 x 50mm (Tyr 2)
Cable connection:	<b>M8 plug-in connector</b> , EtherCATP-encoded
Ambient temperature:	Measuring transducer -30...+70°C
Permitted humidity:	<95% r. H., non-precipitating air
Protection class:	III (according to EN 60730)
Protection type:	<b>IP 54</b> (according to EN 60529) when built-in
Standards:	CE conformity, according to EMC Directive 2014 / 30 / EU, according to RED 2014 / 53 / EU
Equipment:	<b>Display with illumination</b> , 3-line, customised programming, cutout approx. W51 x H29mm, to display the actual temperature or a customised display value. <b>Bar graph</b> , 7-digit, LEDs freely configurable, to graphically display the reading.

**ACCESSORIES** See table

EtherCAT P	LED status display
<b>1. LED</b>	<b>"IN"</b>
off	no connection to upstream EtherCAT module
illuminated	LINK: connection to upstream EtherCAT module
blinking	ACT: communication with upstream EtherCAT module
<b>2. LED</b>	<b>"OUT"</b>
off	no connection to downstream EtherCAT module
illuminated	LINK: connection to downstream EtherCAT module
blinking	ACT: communication with downstream EtherCAT module
<b>3. LED</b>	<b>"RUN"</b>
off	EtherCAT module is in "Init" state
quickly blinking	EtherCAT module is in "Pre-Operational" state
slowly blinking	EtherCAT module is in "Safe-Operational" state
illuminated	EtherCAT module is in "Operational" state

**The status LEDs are next to the cable connection.**

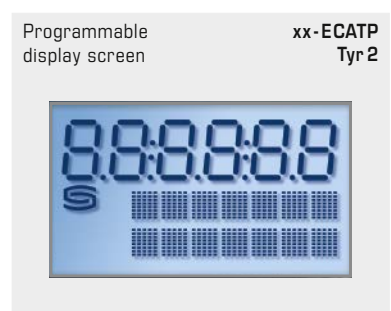
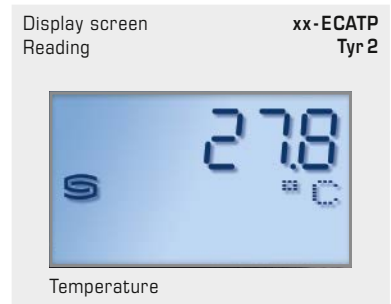





**NEW**

S+S REGELTECHNIK

**THERMASGARD® TM65 - EtherCAT P**

Immersion / screw-in / duct  
temperature measuring transducer, Bluetooth-enabled,  
with EtherCAT port

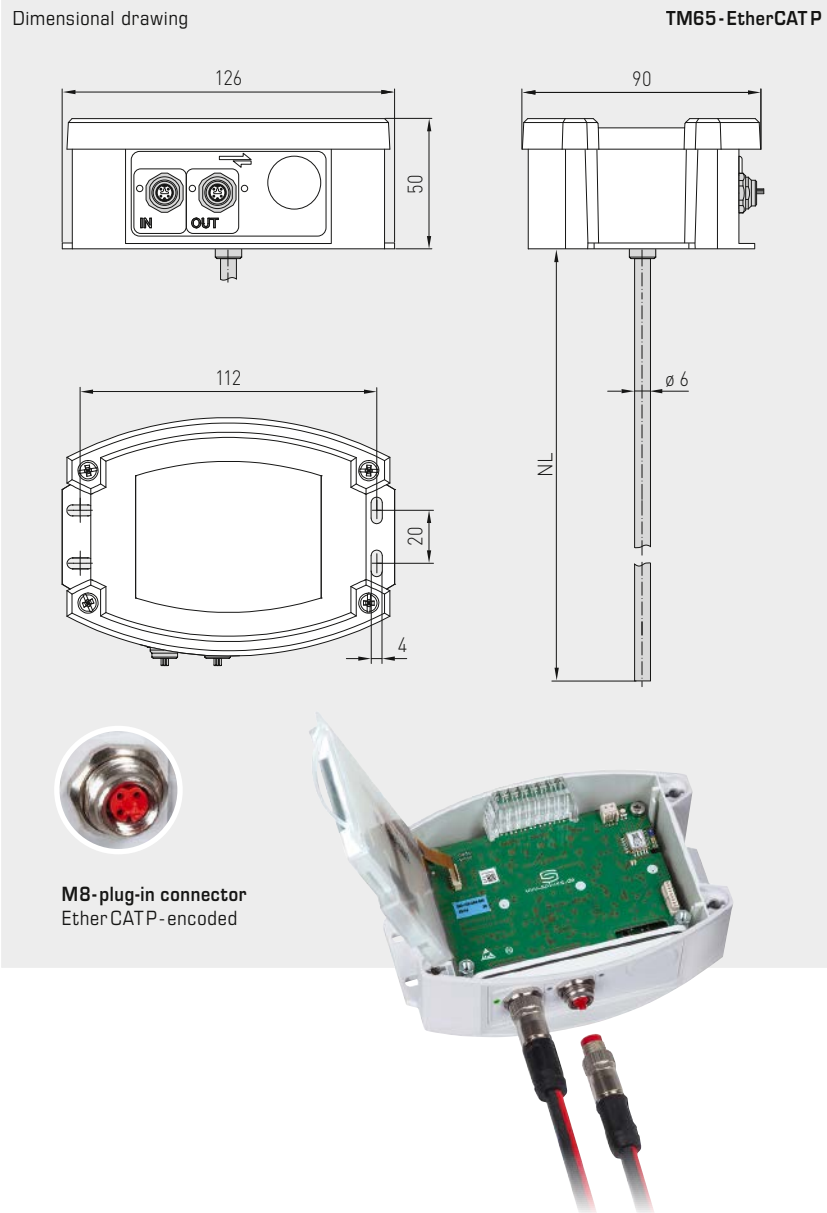

High-performance encapsulation against  
vibration, mechanical stress and humidity

**PS-PROTECTION**  
PERFECT SENSOR PROTECTION

THERMASGARD® TM65 - EtherCAT P		Temperature measuring transducer (basic unit), with EtherCAT port				
Type / WG02	Measuring Range Temperature	Output	Inserted Length (EL)	Bar graph Display	Item No.	Price
TM65-ECATP xx						
TM65-ECATP 50mm	-50...+150 °C	EtherCAT P	50 mm		2001-4201-9100-011	325,67 €
TM65-ECATP 50mm LCD				<input type="checkbox"/> <input checked="" type="checkbox"/>	2001-4202-9100-011	369,73 €
TM65-ECATP 100mm	-50...+150 °C	EtherCAT P	100 mm		2001-4201-9100-021	326,08 €
TM65-ECATP 100mm LCD				<input type="checkbox"/> <input checked="" type="checkbox"/>	2001-4202-9100-021	370,14 €
TM65-ECATP 150mm	-50...+150 °C	EtherCAT P	150 mm		2001-4201-9100-031	326,51 €
TM65-ECATP 150mm LCD				<input type="checkbox"/> <input checked="" type="checkbox"/>	2001-4202-9100-031	370,56 €
TM65-ECATP 200mm	-50...+150 °C	EtherCAT P	200 mm		2001-4201-9100-041	326,92 €
TM65-ECATP 200mm LCD				<input type="checkbox"/> <input checked="" type="checkbox"/>	2001-4202-9100-041	370,97 €
TM65-ECATP 250mm	-50...+150 °C	EtherCAT P	250 mm		2001-4201-9100-051	327,32 €
TM65-ECATP 250mm LCD				<input type="checkbox"/> <input checked="" type="checkbox"/>	2001-4202-9100-051	371,37 €
TM65-ECATP 300mm	-50...+150 °C	EtherCAT P	300 mm		2001-4201-9100-061	327,74 €
TM65-ECATP 300mm LCD				<input type="checkbox"/> <input checked="" type="checkbox"/>	2001-4202-9100-061	371,79 €
TM65-ECATP 400mm	-50...+150 °C	EtherCAT P	400 mm		2001-4201-9100-081	328,15 €
TM65-ECATP 400mm LCD				<input type="checkbox"/> <input checked="" type="checkbox"/>	2001-4202-9100-081	372,20 €

**Note:** Cable connection with **M8 plug-in connector** (EtherCAT P-encoded)

Immersion / screw-in / duct  
temperature measuring transducer, Bluetooth-enabled,  
with EtherCAT P port

One basic device in four variants ...



**TM65-ECATP +  
TH -ms /xx**

Immersion / screw-in  
temperature sensor  
with immersion sleeve,  
brass, nickel-plated

**TM65-ECATP +  
TH -VA /xx**

Immersion / screw-in  
temperature sensor  
with immersion sleeve,  
stainless steel, V4A

**TM65-ECATP +  
TH -VA /xx /90**

Immersion / screw-in  
temperature sensor with  
immersion sleeve with  
neck tube, stainless steel, V4A

**TM65-ECATP +  
MF-06-K**

Duct temperature sensor  
with mounting flange,  
plastic

Dimensional drawing  
**TH -ms /xx**

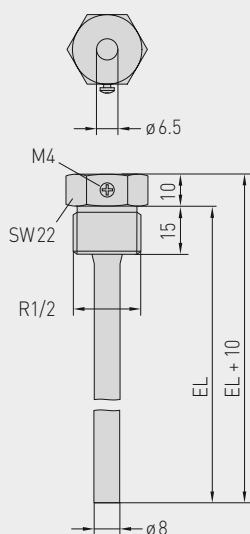

Dimensional drawing  
**TH -VA /xx**

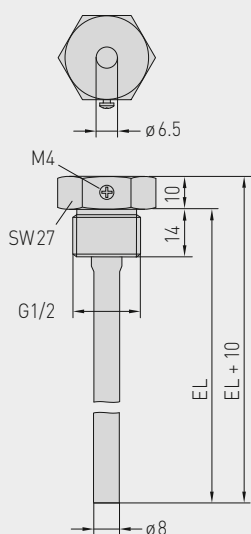

Dimensional drawing  
**TH -VA /xx /90**

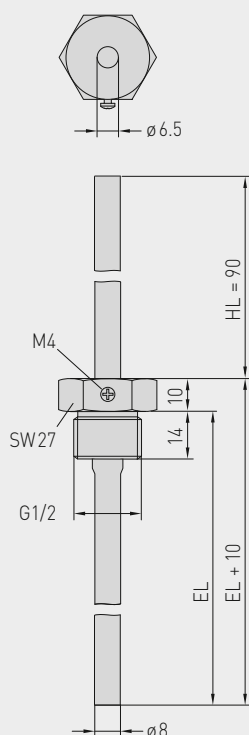

Dimensional drawing  
**MF-06-K**

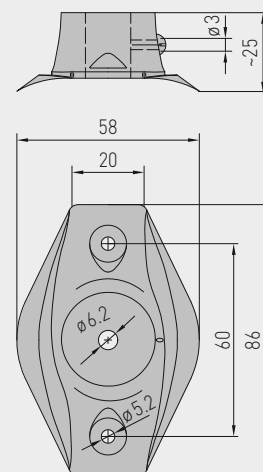





S+S REGELTECHNIK

**NEW**

**THERMASGARD® TM65-EtherCAT P**

Immersion / screw-in / duct  
temperature measuring transducer, Bluetooth-enabled,  
with EtherCAT port

... through combination with accessories:



**TH - ms / xx**

Immersion sleeve,  
brass, nickel-plated,  
thread-sealing, conical,  
according to DIN 10226



**TH - VA / xx**

Immersion sleeve,  
stainless steel, V4A,  
flat-sealing, cylindrical,  
according to DIN 228



**TH - VA / xx / 90**

Immersion sleeve with neck tube,  
stainless steel, V4A,  
flat-sealing, cylindrical,  
according to DIN 228



**MF-06-K**

Mounting flange,  
plastic

THERMASGARD® TH Immersion sleeve Ø 8 mm (Accessories)					
Type / WG01	p <sub>max</sub> (static)	T <sub>max</sub>	Inserted Length (EL)	Item No.	Price
<b>TH - ms / xx</b>	<b>Brass nickel-plated</b>			without neck tube	
TH-MS 50MM	10 bar	+150 °C	<b>50 mm</b>	7100-0011-0010-001	<b>8,87 €</b>
TH-MS 100MM	10 bar	+150 °C	<b>100 mm</b>	7100-0011-0020-001	<b>10,10 €</b>
TH-MS 150MM	10 bar	+150 °C	<b>150 mm</b>	7100-0011-0030-001	<b>10,67 €</b>
TH-MS 200MM	10 bar	+150 °C	<b>200 mm</b>	7100-0011-0040-001	<b>11,01 €</b>
TH-MS 250MM	10 bar	+150 °C	<b>250 mm</b>	7100-0011-0050-001	<b>12,75 €</b>
TH-MS 300MM	10 bar	+150 °C	<b>300 mm</b>	7100-0011-0060-001	<b>13,10 €</b>
TH-MS 350MM	10 bar	+150 °C	<b>350 mm</b>	7100-0011-0070-001	<b>13,21 €</b>
TH-MS 400MM	10 bar	+150 °C	<b>400 mm</b>	7100-0011-0080-001	<b>13,33 €</b>
<b>TH - VA / xx</b>	<b>Stainless steel V4A (1.4571)</b>			without neck tube	
TH-VA 50MM	40 bar	+600 °C	<b>50 mm</b>	7100-0012-0010-001	<b>19,31 €</b>
TH-VA 100MM	40 bar	+600 °C	<b>100 mm</b>	7100-0012-0020-001	<b>21,34 €</b>
TH-VA 150MM	40 bar	+600 °C	<b>150 mm</b>	7100-0012-0030-001	<b>22,93 €</b>
TH-VA 200MM	40 bar	+600 °C	<b>200 mm</b>	7100-0012-0040-001	<b>24,17 €</b>
TH-VA 250MM	40 bar	+600 °C	<b>250 mm</b>	7100-0012-0050-001	<b>30,05 €</b>
TH-VA 300MM	40 bar	+600 °C	<b>300 mm</b>	7100-0012-0060-001	<b>31,40 €</b>
TH-VA 350MM	40 bar	+600 °C	<b>350 mm</b>	7100-0012-0070-001	<b>31,61 €</b>
TH-VA 400MM	40 bar	+600 °C	<b>400 mm</b>	7100-0012-0080-001	<b>32,17 €</b>
<b>TH - VA / xx / 90</b>	<b>Stainless steel V4A (1.4571)</b>			with neck tube (90 mm)	
TH-VA 50/90MM	40 bar	+600 °C	<b>50 mm</b>	7100-0012-2010-001	<b>27,66 €</b>
TH-VA 100/90MM	40 bar	+600 °C	<b>100 mm</b>	7100-0012-2020-001	<b>28,90 €</b>
TH-VA 150/90MM	40 bar	+600 °C	<b>150 mm</b>	7100-0012-2030-001	<b>30,32 €</b>
TH-VA 200/90MM	40 bar	+600 °C	<b>200 mm</b>	7100-0012-2040-001	<b>31,61 €</b>
TH-VA 250/90MM	40 bar	+600 °C	<b>250 mm</b>	7100-0012-2050-001	<b>33,13 €</b>
TH-VA 300/90MM	40 bar	+600 °C	<b>300 mm</b>	7100-0012-2060-001	<b>35,91 €</b>
Note:	inner diameter of socket 6.5 mm For further information see last chapter!				
Mounting flange (Accessories)					
Type / WG01				Item No.	Price
<b>MF xx</b>					
MF-06-K	<b>Mounting flange, plastic,</b> 56.8x84.3 mm, Ø 6.2 mm tube gland, T <sub>max</sub> +100°C			7100-0030-1000-000	<b>5,83 €</b>
Note:	For information see last chapter!				

**Mean value temperature measuring transducer, incl. mounting flange, Bluetooth-enabled, with EtherCAT port**

Networkable mean value temperature measuring transducer **THERMASGARD® MWTM-EtherCAT P** with M8 plug-in connector (EtherCATP-encoded), Bluetooth-enabled, in an impact-resistant plastic housing with quick-locking screws, optionally with /without display and bar graph, with bendable sensor rod (0.4...20m, fully active) in a robust plastic-coated protective copper tube, incl. mounting flange.

The rod sensor is used to detect the mean temperature (mean value) in gaseous media. It is used in ventilation and air conditioning ducts over the entire cross-section or on a defined length (laid along a meandering route, it uniformly detects the surrounding temperature). For proper mounting of the rod, mounting clamps **MK-05-M** (accessory) are available. The sensor is factory-calibrated.

**EtherCATP-enabled measuring transducer** for industrial requirements with maximum reliability: includes easy PLC integration using the device's ESI configuration file, diagnostics (such as communication failure counter), advanced settings options, access to historical data (min / max) and establishing the sensor's service interval. Optionally with large illuminated display (3-line, customised programming in the 7-segment and dot-matrix range) and bar graph (7-digit, LEDs freely configurable) for graphical display, e.g., as a traffic light indicator.

**MWTM-EtherCAT P**  
Rod length  
0,4 m



**EtherCAT P**  
Cable connection and  
LED status display

**TECHNICAL DATA**

Power supply:	24 V DC via EtherCATP (U <sub>S</sub> )
Power consumption:	< 3 W
Bus protocol:	<b>EtherCAT</b>
Radio technology:	<b>Bluetooth</b> (LE)
Sensor:	Pt1000, DIN EN 60751, class B
Measuring range:	-50...+150 °C <b>T<sub>min</sub> -50 °C, T<sub>max</sub> +80 °C</b>
Deviation in temperature:	Typically ±0.2 K at +25 °C
Medium:	Clean air and non-aggressive, non-combustible gases
<b>Sensors:</b>	active across the entire length (averaging)
Rod material:	<b>protective tube made from copper, plastic-coated,</b> with anti-kink spring and sleeve, stainless steel V4A (1.4571)
Rod dimensions:	Ø = 5.0 mm, nominal length (NL) = 0.4 m / 3 m / 6 m (nominal length optionally up to max. 20 m)
Rod laying:	Bending radius: <b>&gt; 35 mm</b> Vibration load: <b>≤ 0.5 g</b> Tensile load: <b>&lt; 480 N</b>
Housing:	Plastic, UV-resistant, polyamide material, 30% glass-globe reinforced, with quick-locking screws (slotted / Phillips head combination), colour traffic white (similar to RAL 9016), housing cover for display is transparent!
Dimensions:	126 x 90 x 50mm (Tyr 2)
Cable connection:	<b>M8 plug-in connector</b> , EtherCATP-encoded
Process connection:	Using plastic mounting flange (included in the delivery scope) and mounting clamps <b>MK-05-M</b> (optional accessory)
Ambient temperature:	Measuring transducer -30...+70 °C
Permitted humidity:	< 95% r. H., non-precipitating air
Protection class:	III (according to EN 60 730)
Protection type:	<b>IP 54</b> (according to EN 60 529) when built-in
Standards:	CE conformity, according to EMC Directive 2014 / 30 / EU, according to RED 2014 / 53 / EU
Equipment:	<b>Display with illumination</b> , 3-line, customised programming, cutout approx. W51 x H29mm, to display the actual temperature or a customised display value. <b>Bar graph</b> , 7-digit, LEDs freely configurable, to graphically display the reading.

**ACCESSORIES** See table

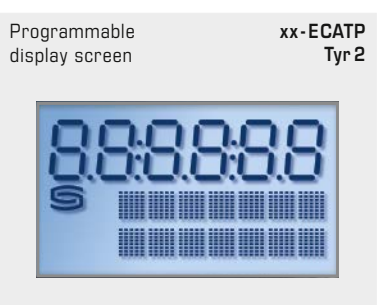
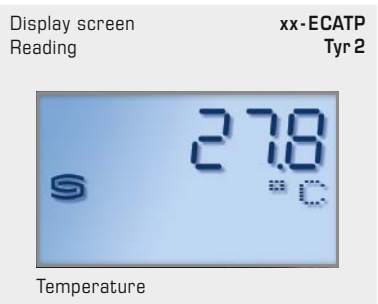





**NEW**

S+S REGELTECHNIK

Thermasgard® MWTM-EtherCAT P

Mean value temperature measuring transducer,  
incl. mounting flange, Bluetooth-enabled,  
with EtherCAT port

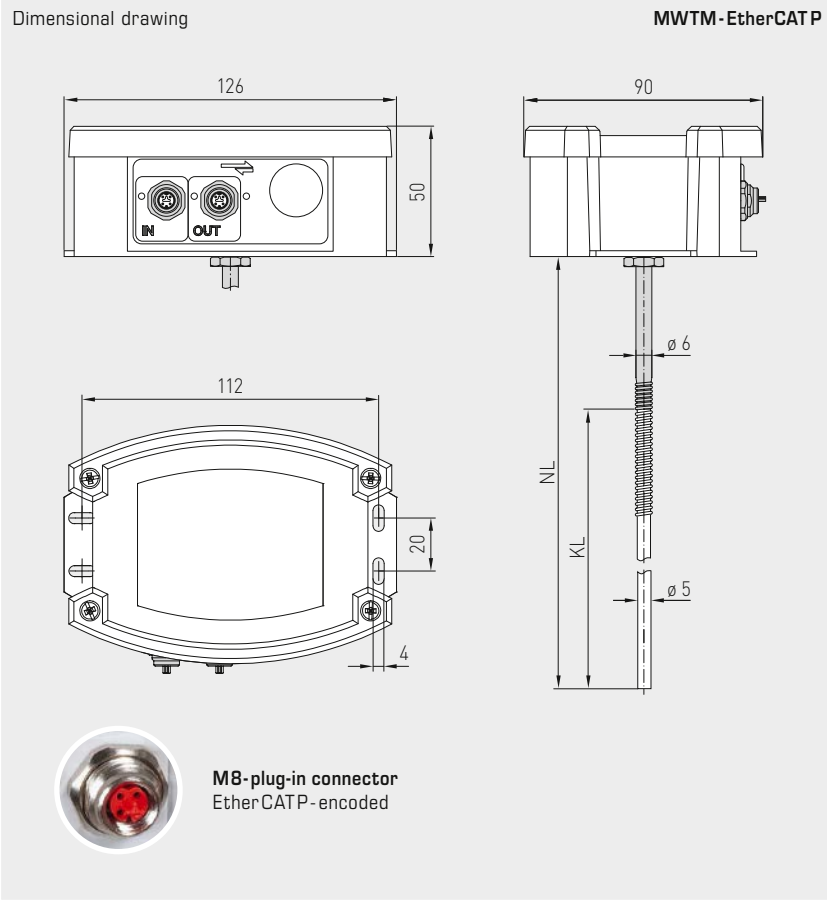

**MWTM-EtherCAT P**  
Rod length  
3 m / 6 m

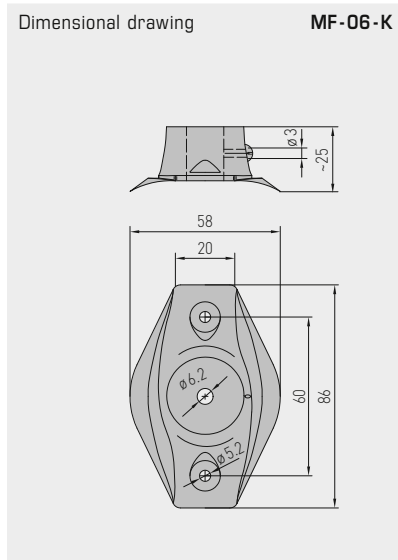
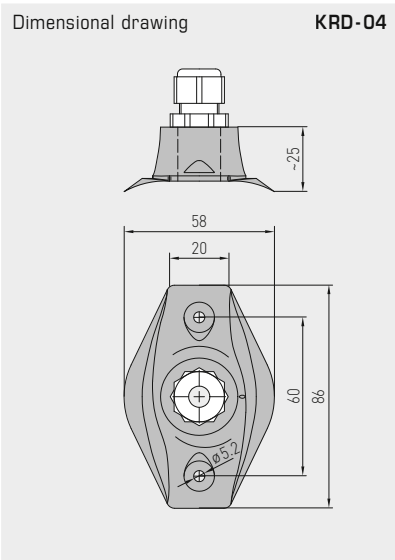

**MF-06-K**  
Mounting flange,  
plastic  
(included in the  
scope of delivery)



**KRD-04**  
Capillary tube  
gland bracket,  
plastic  
(optional)

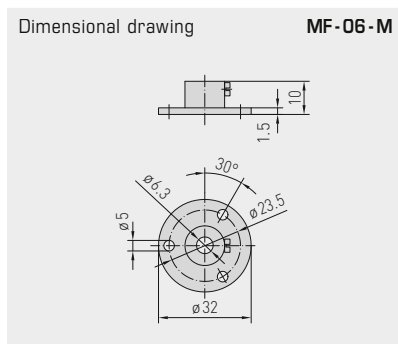
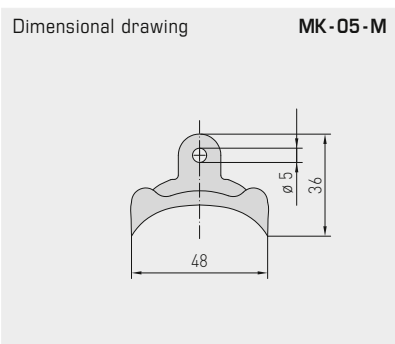

**MF-06-M**  
Mounting flange,  
metal  
(optional)



**MK-05-M**  
Galvanised steel  
mounting clamps  
(optional)



Mean value temperature measuring transducer,  
incl. mounting flange, Bluetooth-enabled,  
with EtherCAT P port

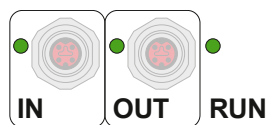

MWTM-EtherCAT P  
with display and bar graph



EtherCAT P	LED status display
<b>1. LED</b>	<b>"IN"</b>
off	no connection to upstream EtherCAT module
illuminated	LINK: connection to upstream EtherCAT module
blinking	ACT: communication with upstream EtherCAT module
<b>2. LED</b>	<b>"OUT"</b>
off	no connection to downstream EtherCAT module
illuminated	LINK: connection to downstream EtherCAT module
blinking	ACT: communication with downstream EtherCAT module
<b>3. LED</b>	<b>"RUN"</b>
off	EtherCAT module is in "Init" state
quickly blinking	EtherCAT module is in "Pre-Operational" state
slowly blinking	EtherCAT module is in "Safe-Operational" state
illuminated	EtherCAT module is in "Operational" state
<b>The status LEDs are next to the cable connection.</b>	





**NEW**

S+S REGELTECHNIK

Mean value temperature measuring transducer,  
incl. mounting flange, Bluetooth-enabled,  
with EtherCAT port

**MWTM-EtherCATP**

Rod length  
3 m / 6 m

**MWTM-EtherCATP**

Rod length  
0,4 m

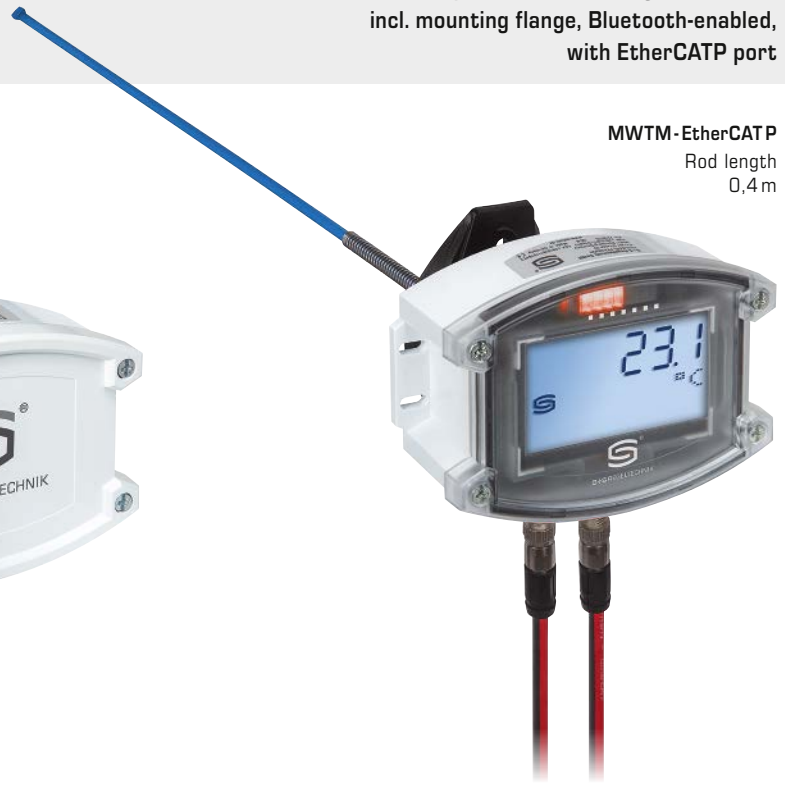

**THERMASGARD® MWTM-EtherCATP** Mean value temperature measuring transducer with EtherCAT port

Type / WG02	Measuring Range Temperature	Output	Rod length	Bar graph Display	Item No.	Price
<b>MWTM-ECATP xx</b>						
MWTM-ECATP 0,4m	-50...+150 °C	EtherCAT P	0,4 m		2001-4211-9100-001	366,43 €
MWTM-ECATP 0,4m LCD				<input type="checkbox"/> <input checked="" type="checkbox"/>	2001-4212-9100-001	410,49 €
MWTM-ECATP 3,0m	-50...+150 °C	EtherCAT P	3,0 m		2001-4211-9100-011	399,37 €
MWTM-ECATP 3,0m LCD				<input type="checkbox"/> <input checked="" type="checkbox"/>	2001-4212-9100-011	443,43 €
MWTM-ECATP 6,0m	-50...+150 °C	EtherCAT P	6,0 m		2001-4211-9100-021	440,54 €
MWTM-ECATP 6,0m LCD				<input type="checkbox"/> <input checked="" type="checkbox"/>	2001-4212-9100-021	484,60 €

**Note:** Cable connection with **M8 plug-in connector** (EtherCATP-encoded)

**ACCESSORIES**

<b>MF-06-K</b>	Mounting flange, plastic (included in the scope of delivery)	7100-0030-1000-000	5,83 €
<b>MF-06-M</b>	Mounting flange, metal, galvanised steel, Ø = 35 mm	7100-0030-5000-100	9,10 €
<b>KRD-04</b>	Capillary tube gland bracket, plastic	7100-0030-7000-000	8,49 €
<b>MK-05-M</b>	Galvanised steel mounting clamps (6 pieces)	7100-0034-0000-000	9,41 €

For further information, see last chapter Accessories!



Sleeve sensor with temperature measuring transducer, Bluetooth-enabled, with EtherCATP port

Networkable sleeve temperature measuring transducer THERMASGARD® HFTM-EtherCATP with M8 plug-in connector (EtherCATP-encoded), Bluetooth-enabled, in an impact-resistant plastic housing with quick-locking screws, optionally with/without display and bar graph, cable sensor with stainless steel sleeve.

The sleeve sensor is used to detect the temperature in liquid and gaseous media. It is used as a duct sensor or, if installed in an immersion sleeve THE (accessory), as an immersion and screw-in sensor in liquids. The sensor is factory-calibrated.

**EtherCATP-enabled measuring transducer** for industrial requirements with maximum reliability: includes easy PLC integration using the device's ESI configuration file, diagnostics (such as communication failure counter), advanced settings options, access to historical data (min / max) and establishing the sensor's service interval. Optionally with large illuminated display (3-line, customised programming in the 7-segment and dot-matrix range) and bar graph (7-digit, LEDs freely configurable) for graphical display, e.g., as a traffic light indicator.

HFTM-EtherCATP



EtherCATP Cable connection and LED status display

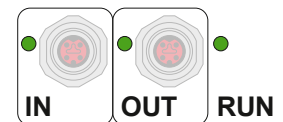

TECHNICAL DATA	
Power supply:	24 V DC via EtherCATP (U <sub>S</sub> )
Power consumption:	< 3 W
Bus protocol:	<b>EtherCAT</b>
Radio technology:	<b>Bluetooth</b> (LE)
Sensor:	Pt1000, DIN EN 60751, class B ( <b>Perfect Sensor Protection</b> at IP68)
Measuring range:	-50...+150 °C; T <sub>max</sub> <b>bis +150 °C</b>
Deviation in temperature:	Typically ± 0.2 K at +25 °C
Medium:	Clean air and non-aggressive, non-combustible gases; liquids depending on selected immersion sleeve (accessory)
Sensor protection:	Sensor sleeve made from stainless steel V4A (1.4571), Ø = 6 mm, nominal length (NL) = 50 mm (optional 30...400 mm)
Sensor cable:	Silicone, SiHF, 2 x 0.25 mm <sup>2</sup> ; cable length (CL) = 1.5 m (optionally also other lengths and measuring range limits, e.g., PTFE up to +250 °C or glass fibre with steel mesh up to +350 °C)
Housing:	Plastic, UV-resistant, polyamide material, 30% glass-globe reinforced, with quick-locking screws (slotted / Phillips head combination), colour traffic white (similar to RAL 9016), housing cover for display is transparent!
Dimensions:	126 x 90 x 50 mm (Tyr 2)
Cable connection:	<b>M8 plug-in connector</b> , EtherCATP-encoded
Ambient temperature:	Measuring transducer -30...+70 °C
Permitted humidity:	< 95% r. H., non-precipitating air
Protection class:	III (according to EN 60 730)
Protection type housing:	<b>IP 54</b> (according to EN 60 529)
Protection type sensor:	<b>IP 65</b> (according to EN 60 529) <b>sleeve</b> humidity-tight (standard) <b>IP 68</b> (according to EN 60 529) <b>sleeve</b> water-tight (optional) <b>IP 54</b> (according to EN 60 529) with <b>glass fibre</b> cable (optional)
Standards:	CE conformity, according to EMC Directive 2014 / 30 / EU, according to RED 2014 / 53 / EU
Equipment:	<b>Display with illumination</b> , 3-line, customised programming, cutout approx. W51 x H29mm, to display the actual temperature or a customised display value. <b>Bar graph</b> , 7-digit, LEDs freely configurable, to graphically display the reading.

ACCESSORIES	
EtherCAT P	LED status display
<b>1. LED</b>	<b>"IN"</b>
off	no connection to upstream EtherCAT module
illuminated	LINK: connection to upstream EtherCAT module
blinking	ACT: communication with upstream EtherCAT module
<b>2. LED</b>	<b>"OUT"</b>
off	no connection to downstream EtherCAT module
illuminated	LINK: connection to downstream EtherCAT module
blinking	ACT: communication with downstream EtherCAT module
<b>3. LED</b>	<b>"RUN"</b>
off	EtherCAT module is in "Init" state
quickly blinking	EtherCAT module is in "Pre-Operational" state
slowly blinking	EtherCAT module is in "Safe-Operational" state
illuminated	EtherCAT module is in "Operational" state

The status LEDs are next to the cable connection.

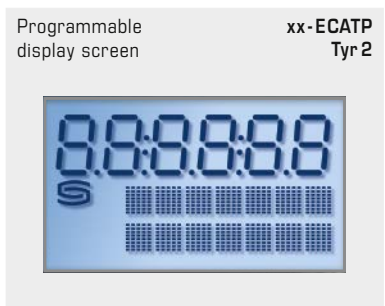
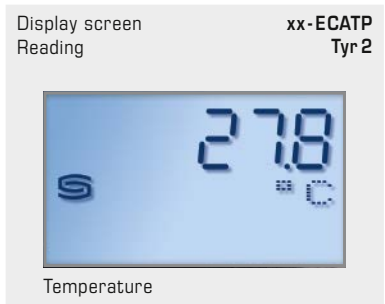





**NEW**

S+S REGELTECHNIK

THERMASGARD® HFTM - EtherCAT P

Sleeve sensor with temperature measuring transducer,  
Bluetooth-enabled,  
with EtherCAT port

Dimensional drawing

HFTM - EtherCAT P

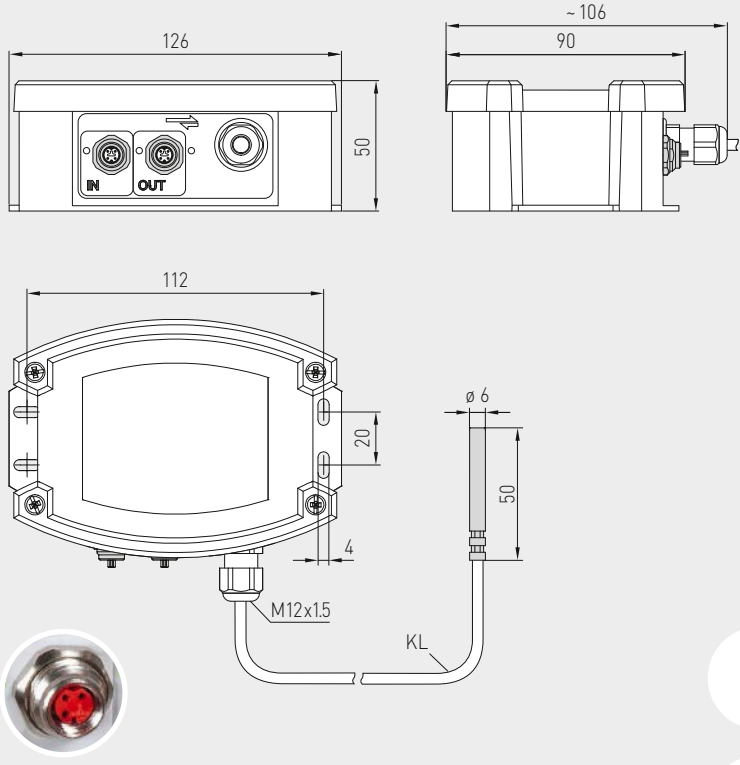

M8-plug-in connector  
EtherCAT P-encoded



HFTM - EtherCAT P  
with display and bar graph



IP65 (standard)  
humidity-tight

IP68 (optional)  
watertight  
**Perfect Sensor Protection**

IP54 (optional)  
with glass fibre cable

High-performance encapsulation against  
vibration, mechanical stress and humidity

**PS-PROTECTION**  
PERFECT SENSOR PROTECTION

THERMASGARD®  
HFTM - EtherCAT P

Sleeve sensors with temperature measuring transducer  
with EtherCAT port

Type / WG02	Measuring Range Temperature	Sensor	Output	Bar graph Display	Item No.	Price
<b>HFTM-ECATP xx</b>						
HFTM-ECATP	-50...+150 °C	Pt1000	EtherCAT P		2001-2161-9100-001	<b>337,62 €</b>
HFTM-ECATP LCD	-50...+150 °C	Pt1000	EtherCAT P	☐ ■	2001-2162-9100-001	<b>381,67 €</b>
<b>Note:</b>	Cable connection with <b>M8 plug-in connector</b> (EtherCAT P-encoded)					
Extra charge:	Protection type <b>IP68</b> (sensor sleeve watertight compound-filled) per running metre of connecting lead ( <b>silicone/PTFE/glass fibre</b> ) other protection sleeve lengths (optional 30...400 mm)				on request on request	<b>3,24 €</b>

**ACCESSORIES**

**THE-xx** Immersion sleeve, stainless steel V4A (1.4571) or nickel-plated brass, Ø = 9 mm  
For further information, see last chapter Accessories!

For further information, see last chapter Accessories!



Surface-contact temperature measuring transducer / pipe surface-contact sensor, with detached sensor, incl. strap, Bluetooth-enabled, with EtherCATP port

Networkable surface-contact temperature measuring transducer (detached version) THERMASGARD® ALTM2 - EtherCATP with M8 plug-in connector (EtherCATP-encoded), Bluetooth-enabled, in an impact-resistant plastic housing with quick-locking screws, optionally with /without display and bar graph, cable sensor with pipe feeder, incl. strap.

The pipe surface-contact sensor is used to detect the temperature on lines, pipes (e.g., cold and warm water) or on heating sections for heating control. The sensor is factory-calibrated.

**EtherCATP-enabled measuring transducer** for industrial requirements with maximum reliability: includes easy PLC integration using the device's ESI configuration file, diagnostics (such as communication failure counter), advanced settings options, access to historical data (min / max) and establishing the sensor's service interval. Optionally with large illuminated display (3-line, customised programming in the 7-segment and dot-matrix range) and bar graph (7-digit, LEDs freely configurable) for graphical display, e.g., as a traffic light indicator.

ALTM2-EtherCATP



EtherCATP Cable connection and LED status display

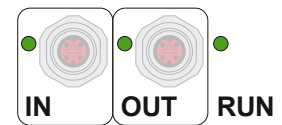

TECHNICAL DATA	
Power supply:	24 V DC via EtherCATP (U <sub>0</sub> )
Power consumption:	< 3 W
Bus protocol:	<b>EtherCAT</b>
Radio technology:	<b>Bluetooth (LE)</b>
Sensor:	Pt1000, DIN EN 60751, class B ( <b>Perfect Sensor Protection</b> at IP68)
Measuring range:	-50...+150 °C
Deviation in temperature:	typically ±0.2 K at +25 °C
Medium:	clean air and non-aggressive, non-combustible gases
Sensor protection:	pipe feeder made of stainless steel <b>V4A</b> (1.4571), Ø = 6 mm, L = 50 mm
Sensor cable:	Silicone, SiHF, 2 x 0.25 mm <sup>2</sup> ; cable length (CL) = 1.5 m (optionally also other lengths and measuring range limits, e.g., PTFE up to +250 °C or glass fibre with steel mesh up to +350 °C)
Housing:	Plastic, UV-resistant, polyamide material, 30 % glass-globe reinforced, with quick-locking screws (slotted / Phillips head combination), colour traffic white (similar to RAL 9016), housing cover for display is transparent!
Dimensions:	126 x 90 x 50 mm (Tyr 2)
Cable connection:	<b>M8 plug-in connector</b> , EtherCATP-encoded
Process connection:	Endless strap with metal tightener (included in delivery scope), Ø = 13-92 mm (1/4 - 3"), L = 300 mm
Ambient temperature:	Measuring transducer -30...+70 °C
Permitted humidity:	< 95 % r. H., non-precipitating air
Protection class:	III (according to EN 60 730)
Protection type housing:	<b>IP 54</b> (according to EN 60 529)
Protection type sensor:	<b>IP 65</b> (according to EN 60 529) <b>sleeve</b> humidity-tight (standard) <b>IP 68</b> (according to EN 60 529) <b>sleeve</b> water-tight (optional)
Standards:	CE conformity, according to EMC Directive 2014 / 30 / EU, according to RED 2014 / 53 / EU
Equipment:	<b>Display with illumination</b> , 3-line, customised programming, cutout approx. W51 x H29mm, to display the actual temperature or a customised display value. <b>Bar graph</b> , 7-digit, LEDs freely configurable, to graphically display the reading.

ACCESSORIES	See table
<b>EtherCAT P</b>	<b>LED status display</b>
<b>1. LED</b>	<b>"IN"</b>
off	no connection to upstream EtherCAT module
illuminated	LINK: connection to upstream EtherCAT module
blinking	ACT: communication with upstream EtherCAT module
<b>2. LED</b>	<b>"OUT"</b>
off	no connection to downstream EtherCAT module
illuminated	LINK: connection to downstream EtherCAT module
blinking	ACT: communication with downstream EtherCAT module
<b>3. LED</b>	<b>"RUN"</b>
off	EtherCAT module is in "Init" state
quickly blinking	EtherCAT module is in "Pre-Operational" state
slowly blinking	EtherCAT module is in "Safe-Operational" state
illuminated	EtherCAT module is in "Operational" state

The status LEDs are next to the cable connection.

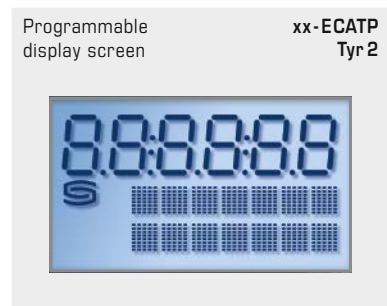
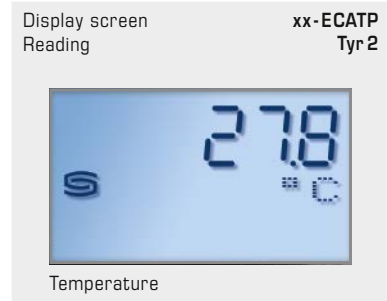





**NEW**

S+S REGELTECHNIK

THERMASGARD® **ALTM2-EtherCAT P**

Surface-contact temperature measuring transducer / pipe surface-contact sensor, with detached sensor, incl. strap, Bluetooth-enabled, with EtherCAT P port

Dimensional drawing

ALTM2-EtherCAT P

ALTM2-EtherCAT P with display and bar graph

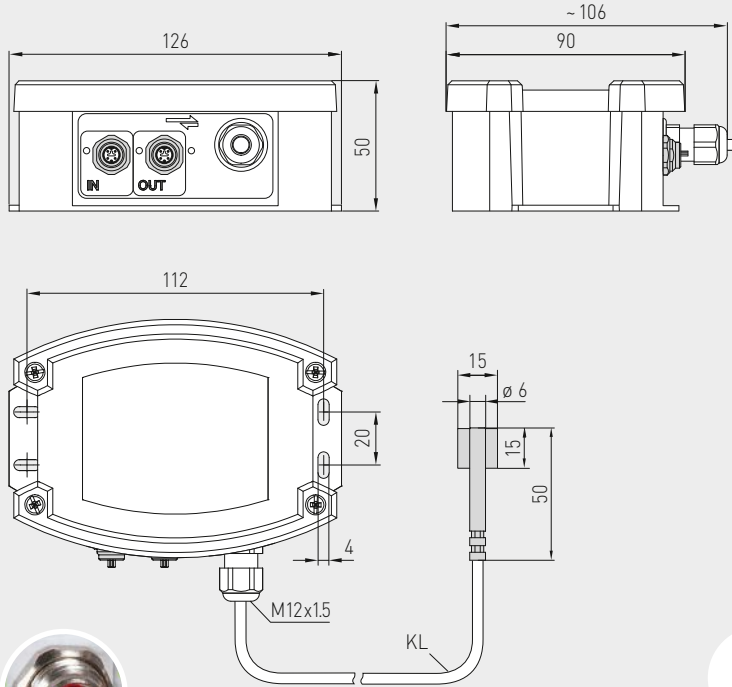

M8-plug-in connector EtherCAT P-encoded



IP65 (standard) humidity-tight

IP68 (optional) watertight **Perfect Sensor Protection**

IP54 (optional) with glass fibre cable

High-performance encapsulation against vibration, mechanical stress and humidity

**PS-PROTECTION**  
PERFECT SENSOR PROTECTION

THERMASGARD® ALTM2-EtherCAT P Surface-contact temperature measuring transducer with detached sensor, with EtherCAT P

Type / WG02	Measuring Range Temperature	Sensor	Output	Bar graph Display	Item No.	Price
<b>ALTM2-ECATP xx</b>						
ALTM2-ECATP	-50...+150 °C	Pt1000	EtherCAT P		2001-2171-9100-001	<b>340,65 €</b>
ALTM2-ECATP LCD	-50...+150 °C	Pt1000	EtherCAT P	☐ ■	2001-2172-9100-001	<b>384,71 €</b>
<b>Note:</b>	Cable connection with <b>M8 plug-in connector</b> (EtherCAT P-encoded)					
Extra charge:	Protection type <b>IP68</b> (sensor sleeve watertight compound-filled) per running metre of connecting lead ( <b>silicone / PTFE / glass fibre</b> )					<b>3,24 €</b> on request

ACCESSORIES			
<b>WLP-1</b>	Heat-conductive paste, silicone-free	7100-0060-1000-000	<b>3,22 €</b>

For further information, see last chapter Accessories!



**On-wall humidity and temperature sensor ( $\pm 2.0\%$ ),  
for mixture ratio, relative/absolute humidity, dew point, enthalpy  
and temperature, Bluetooth-enabled, with EtherCATP port**

Networkable on-wall humidity and temperature sensor **HYGRASGARD® AFTF-EtherCATP** with M8 plug-in connector (EtherCATP-encoded), Bluetooth-enabled, in an impact-resistant plastic housing with quick-locking screws, optionally with /without display and bar graph, with plastic sinter filter (replaceable).

The sensor is used to detect various parameters in humidity measurement. It measures the **relative humidity** (0...100% r.H.) and the **temperature** ( $-35...+80^{\circ}\text{C}$ ) of the ambient air. These measurands are used internally to calculate further output values: **absolute humidity** (0...80g/m<sup>3</sup>), **mixture ratio** (0...80g/kg), **dew point temperature** ( $-20...+80^{\circ}\text{C}$ ) and **enthalpy** (0...85kJ/kg) while ignoring atmospheric air pressure. A long-term stable, digital sensor guarantees exact measurement results. The sensor is factory-calibrated.

**EtherCATP-enabled measuring transducer** for industrial requirements with maximum reliability: includes easy PLC integration using the device's ESI configuration file, diagnostics (such as communication failure counter), advanced settings options, access to historical data (min / max) and establishing the sensor's service interval. Optionally with large illuminated display (3-line, customised programming in the 7-segment and dot-matrix range) and bar graph (7-digit, LEDs freely configurable) for graphical display, e.g., as a traffic light indicator.

AFTF-EtherCATP



**EtherCATP**  
Cable connection and  
LED status display

**TECHNICAL DATA**

Power supply:	24VDC via EtherCATP (U <sub>S</sub> )
Power consumption:	< 3W
Bus protocol:	<b>EtherCAT</b>
Radio technology:	<b>Bluetooth (LE)</b>
Data points:	Temperature [ $^{\circ}\text{C}$ ], relative humidity [% r.H.], dew point [ $^{\circ}\text{C}$ ], absolute humidity [g/m <sup>3</sup> ], mixture ratio [g/kg], enthalpy [kJ/kg]
Sensor:	<b>Digital humidity sensor with integrated temperature sensor</b> , low hysteresis, high long-term stability
Measuring range:	0...100% r.H. (humidity) $-35...+80^{\circ}\text{C}$ (temperature)
Deviation in humidity:	Typically $\pm 2.0\%$ (20...80% r.H.) at $+25^{\circ}\text{C}$ , otherwise $\pm 3.0\%$
Deviation in temperature:	Typically $\pm 0.4\text{K}$ at $+25^{\circ}\text{C}$
Long-term stability:	$\pm 1\%$ per year
Medium:	Clean air and non-aggressive, non-combustible gases
Sensor protection:	Plastic sinter filter, $\varnothing 14\text{mm}$ , l = 35 mm, replaceable (optionally <b>metal</b> sinter filter, $\varnothing 16\text{mm}$ , l = 32mm)
Protective tube:	Stainless steel <b>V2A</b> (1.4301), $\varnothing 16\text{mm}$ (see dimensional drawing)
Housing:	Plastic, UV-resistant, polyamide material, 30% glass-globe reinforced, with quick-locking screws (slotted / Phillips head combination), colour traffic white (similar to RAL 9016), housing cover for display is transparent!
Dimensions:	126 x 90 x 50mm (Tyr 2)
Cable connection:	<b>M8 plug-in connector</b> , EtherCATP-encoded
Process connection:	Using screw-in device on housing
Ambient temperature:	$-30...+70^{\circ}\text{C}$
Permitted humidity:	< 95% r. H., non-precipitating air
Protection class:	III (according to EN 60 730)
Protection type:	<b>IP 54</b> (according to EN 60 529)
Standards:	CE conformity, according to EMC Directive 2014 / 30 / EU, according to RED 2014 / 53 / EU
Equipment:	<b>Display with illumination</b> , 3-line, customised programming, cutout approx. W 51 x H 29mm, to display actual humidity, actual temperature and/or an alternative characteristic value or a customised display value. <b>Bar graph</b> , 7-digit, LEDs freely configurable, to graphically display the reading.
<b>ACCESSORIES</b>	See table

Display screen Reading **xx-ECATP Tyr 2**



Humidity



Temperature

Programmable display screen **xx-ECATP Tyr 2**





**NEW**

S+S REGELTECHNIK

HYGRASGARD® **AFTF-EtherCAT P**

On-wall humidity and temperature sensor ( $\pm 2.0\%$ ),  
for mixture ratio, relative/absolute humidity, dew point, enthalpy  
and temperature, Bluetooth-enabled, with EtherCAT port

**Dimensional drawing**

**AFTF-EtherCAT P**

**M8-plug-in connector**  
Ether CATP - encoded

**SF-K**  
Plastic sinter filter  
(standard)

**SF-M**  
Metal sinter filter  
(optional)

**AFTF-EtherCAT P**  
with display and bar graph





On-wall humidity and temperature sensor ( $\pm 2.0\%$ ),  
for mixture ratio, relative/absolute humidity, dew point, enthalpy  
and temperature, Bluetooth-enabled, with EtherCAT port

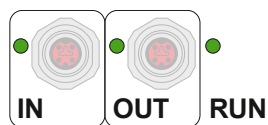

**WS-03**  
Weather and sun protection hood  
(optional)



EtherCAT P	LED status display
<b>1. LED</b>	<b>"IN"</b>
off	no connection to upstream EtherCAT module
illuminated	LINK: connection to upstream EtherCAT module
blinking	ACT: communication with upstream EtherCAT module
<b>2. LED</b>	<b>"OUT"</b>
off	no connection to downstream EtherCAT module
illuminated	LINK: connection to downstream EtherCAT module
blinking	ACT: communication with downstream EtherCAT module
<b>3. LED</b>	<b>"RUN"</b>
off	EtherCAT module is in "Init" state
quickly blinking	EtherCAT module is in "Pre-Operational" state
slowly blinking	EtherCAT module is in "Safe-Operational" state
illuminated	EtherCAT module is in "Operational" state
<b>The status LEDs are next to the cable connection.</b>	

Display screen Reading **xx-ECATP Tyr 2**



Humidity



Temperature

Display screen alternative output variables **xx-ECATP Tyr 2**



Absolute humidity



Mixture ratio



Dew point



Enthalpy

Programmable display screen **xx-ECATP Tyr 2**



Use the EtherCAT interface to program the **LCD display**.  
With only one output value selected, the display is static;  
with several values selected, the display is cyclical with one after the other.  
In the **first line** the value is displayed and in the **second line** the corresponding unit.  
The **third line** is empty by default if there are no customised inputs.  
The entire display in the 7-segment range as well as in the dot-matrix range can be **customised**.



S+S REGELTECHNIK

**NEW**

On-wall humidity and temperature sensor (± 2.0%),  
for mixture ratio, relative/absolute humidity, dew point, enthalpy  
and temperature, Bluetooth-enabled, with EtherCAT port

AFTF-EtherCAT P  
with display and bar graph



**HYGRASGARD®  
AFTF-EtherCAT P**

On-wall humidity and temperature sensor (± 2.0%),  
with EtherCAT port

Type / WG02	Measuring Range / Readout Humidity (switchable)	Temperature	Output	Bar graph Display	Item No.	Price
<b>AFTF-ECATP xx</b>						
AFTF-ECATP	0 ... 100% r. H. (default) 0 ... 80 g / kg (MV) 0 ... 80 g / m <sup>3</sup> (a.F.) 0 ... 85 kJ / kg (ENT.) -20...+80 °C (TP)	-35...+80 °C	EtherCAT P		2003-6261-9100-001	<b>349,96 €</b>
AFTF-ECATP LCD	0 ... 100% r. H. (default) 0 ... 80 g / kg (MV) 0 ... 80 g / m <sup>3</sup> (a.F.) 0 ... 85 kJ / kg (ENT.) -20...+80 °C (TP)	-35...+80 °C	EtherCAT P	<input type="checkbox"/> <input checked="" type="checkbox"/>	2003-6262-9100-001	<b>394,02 €</b>
<b>Note:</b> Cable connection with <b>M8 plug-in connector</b> (EtherCATP-encoded)						

**ACCESSORIES**

<b>WS-03</b>	Sun and ball-impact protection hood, 184x180x80 mm, stainless steel <b>V2A</b> (1.4301)	7100-0040-6000-000	<b>42,61 €</b>
<b>SF-K</b>	Plastic sinter filter, Ø 16 mm, L = 35 mm, exchangeable	7000-0050-2310-000	<b>12,25 €</b>
<b>SF-M</b>	Metal sinter filter, Ø 16 mm, L = 32 mm, exchangeable, stainless steel <b>V4A</b> (1.4404)	7000-0050-2200-100	<b>40,31 €</b>

For further information, see last chapter Accessories!



Duct humidity and temperature sensor ( $\pm 2.0\%$ ),  
for mixture ratio, relative/absolute humidity, dew point, enthalpy  
and temperature, Bluetooth-enabled, with EtherCATP port

Networkable duct humidity and temperature sensor **HYGRASGARD® KFTF-EtherCATP** with M8 plug-in connector (EtherCATP-encoded), Bluetooth-enabled, in an impact-resistant plastic housing with quick-locking screws, optionally with /without display and bar graph, with plastic sinter filter (replaceable), incl. mounting flange.

The sensor is used to detect various parameters in humidity measurement. It measures the **relative humidity** (0...100% r.H.) and the **temperature** (-35...+80°C) of the ambient air. These measurands are used internally to calculate further output values: **absolute humidity** (0...80g/m³), **mixture ratio** (0...80g/kg), **dew point temperature** (-20...+80°C) and **enthalpy** (0...85kJ/kg) while ignoring atmospheric air pressure. A long-term stable, digital sensor guarantees exact measurement results. The sensor is factory-calibrated.

**EtherCATP-enabled measuring transducer** for industrial requirements with maximum reliability: includes easy PLC integration using the device's ESI configuration file, diagnostics (such as communication failure counter), advanced settings options, access to historical data (min / max) and establishing the sensor's service interval. Optionally with large illuminated display (3-line, customised programming in the 7-segment and dot-matrix range) and bar graph (7-digit, LEDs freely configurable) for graphical display, e.g., as a traffic light indicator.



KFTF-EtherCATP

**TECHNICAL DATA**

Power supply:	24 V DC via EtherCATP (U <sub>S</sub> )
Power consumption:	< 3 W
Bus protocol:	<b>EtherCAT</b>
Radio technology:	<b>Bluetooth (LE)</b>
Data points:	Temperature [°C], relative humidity [% r.H.], dew point [°C], absolute humidity [g/m³], mixture ratio [g/kg], enthalpy [kJ/kg]
Sensor:	<b>Digital humidity sensor with integrated temperature sensor</b> , low hysteresis, high long-term stability
Measuring range:	0...100% r.H. (humidity) -35...+80 °C (temperature)
Deviation in humidity:	Typically $\pm 2.0\%$ (20...80% r.H.) at +25 °C, otherwise $\pm 3.0\%$
Deviation in temperature:	Typically $\pm 0.4$ K at +25 °C
Long-term stability:	$\pm 1\%$ per year
Medium:	Clean air and non-aggressive, non-combustible gases
Sensor protection:	Plastic sinter filter, $\varnothing$ 14mm, l = 35 mm, replaceable (optionally <b>metal</b> sinter filter, $\varnothing$ 16mm, l = 32mm)
Protective tube:	<b>PLEUROFORM™</b> , material polyamide (PA6), with torsion protection, $\varnothing$ 20mm, NL = 235mm, v <sub>max</sub> = 30m/s (air) (option available on request in stainless steel <b>V2A</b> (1.4301), $\varnothing$ 16mm)
Housing:	Plastic, UV-resistant, polyamide material, 30% glass-globe reinforced, with quick-locking screws (slotted / Phillips head combination), colour traffic white (similar to RAL 9016), housing cover for display is transparent!
Dimensions:	126 x 90 x 50mm (Tyr 2)
Cable connection:	<b>M8 plug-in connector</b> , EtherCATP-encoded
Process connection:	By plastic mounting flange (included in the delivery scope)
Ambient temperature:	-30...+70 °C
Permitted humidity:	< 95% r. H., non-precipitating air
Protection class:	III (according to EN 60 730)
Protection type:	<b>IP 54</b> (according to EN 60 529)
Standards:	CE conformity, according to EMC Directive 2014 / 30 / EU, according to RED 2014 / 53 / EU
Equipment:	<b>Display with illumination</b> , 3-line, customised programming, cutout approx. W 51 x H 29mm, to display actual humidity, actual temperature and/or an alternative characteristic value or a customised display value. <b>Bar graph</b> , 7-digit, LEDs freely configurable, to graphically display the reading.
<b>ACCESSORIES</b>	See table



**EtherCATP**  
Cable connection and LED status display

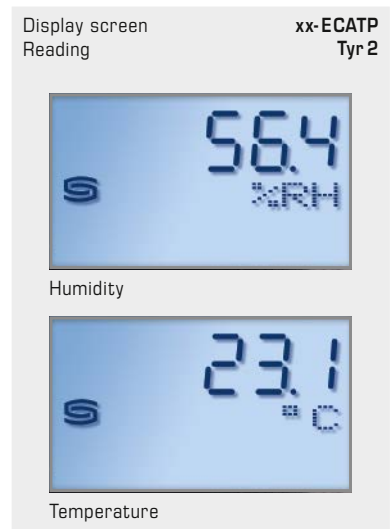

Display screen Reading **xx-ECATP Tyr 2**  
Humidity  
Temperature

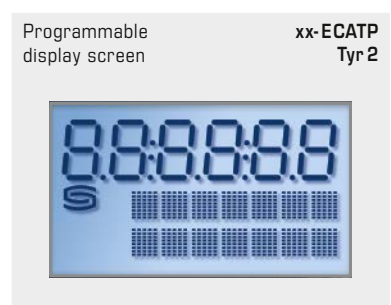

Programmable display screen **xx-ECATP Tyr 2**





**NEW**

S+S REGELTECHNIK

HYGRASGARD® **KFTF-EtherCAT P**

Duct humidity and temperature sensor ( $\pm 2.0\%$ ),  
for mixture ratio, relative/absolute humidity, dew point, enthalpy  
and temperature, Bluetooth-enabled, with EtherCAT port

Dimensional drawing

KFTF-EtherCAT P

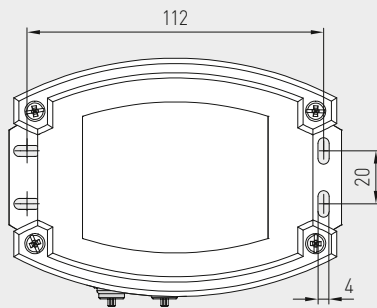
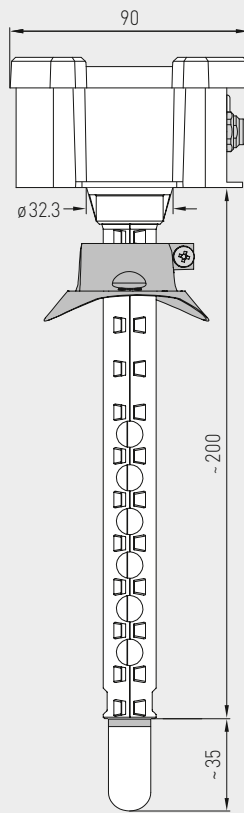
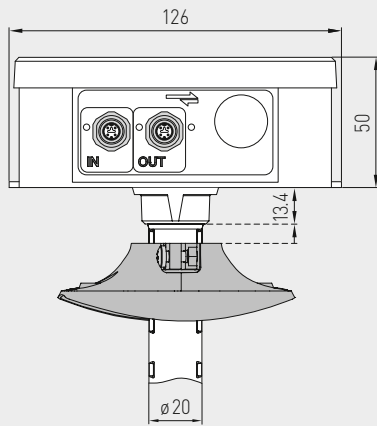

**MB-plug-in connector**  
EtherCAT P-encoded

**SF-K**  
Plastic sinter filter  
(standard)



**SF-M**  
Metal sinter filter  
(optional)



**Protective tube made from stainless steel**  
(optional on request)



**KFTF-EtherCAT P**  
with display and bar graph



Dimensional drawing

**MFT-20-K**

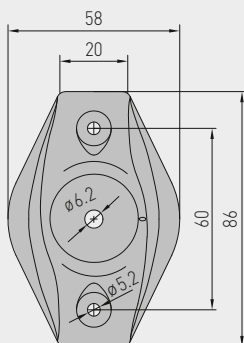
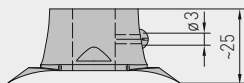

**MFT-20-K**  
Mounting flange,  
plastic  
(included in the scope  
of delivery)



Duct humidity and temperature sensor ( $\pm 2.0\%$ ),  
for mixture ratio, relative/absolute humidity, dew point, enthalpy  
and temperature, Bluetooth-enabled, with EtherCAT port

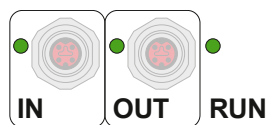

EtherCAT P	LED status display
<b>1. LED</b>	<b>"IN"</b>
off	no connection to upstream EtherCAT module
illuminated	LINK: connection to upstream EtherCAT module
blinking	ACT: communication with upstream EtherCAT module
<b>2. LED</b>	<b>"OUT"</b>
off	no connection to downstream EtherCAT module
illuminated	LINK: connection to downstream EtherCAT module
blinking	ACT: communication with downstream EtherCAT module
<b>3. LED</b>	<b>"RUN"</b>
off	EtherCAT module is in "Init" state
quickly blinking	EtherCAT module is in "Pre-Operational" state
slowly blinking	EtherCAT module is in "Safe-Operational" state
illuminated	EtherCAT module is in "Operational" state
<b>The status LEDs are next to the cable connection.</b>	

Display screen Reading **xx-ECATP Tyr 2**



Humidity



Temperature

Display screen alternative output variables **xx-ECATP Tyr 2**



Absolute humidity



Mixture ratio



Dew point



Enthalpy

Programmable display screen **xx-ECATP Tyr 2**



Use the EtherCAT interface to program the **LCD display**.  
With only one output value selected, the display is static;  
with several values selected, the display is cyclical with one after the other.

In the **first line** the value is displayed and in the **second line** the corresponding unit. The **third line** is empty by default if there are no customised inputs.

The entire display in the 7-segment range as well as in the dot-matrix range can be **customised**.



S+S REGELTECHNIK

**NEW**

HYGRASGARD® **KFTF-EtherCAT P**

Duct humidity and temperature sensor ( $\pm 2.0\%$ ),  
for mixture ratio, relative/absolute humidity, dew point, enthalpy  
and temperature, Bluetooth-enabled, with EtherCAT port

KFTF-EtherCAT P  
with display and bar graph



**HYGRASGARD®**  
**KFTF-EtherCAT P**      Duct humidity and temperature sensor ( $\pm 2.0\%$ ),  
with EtherCAT port

Type / WG02	Measuring Range / Readout Humidity (switchable)	Temperature	Output	Bar graph Display	Item No.	Price
<b>KFTF-ECATP xx</b>						
KFTF-ECATP	0 ... 100 % r. H. (default) 0 ... 80 g / kg (MV) 0 ... 80 g / m <sup>3</sup> (a.F.) 0 ... 85 kJ / kg (ENT.) -20 ... +80 °C (TP)	-35 ... +80 °C	EtherCAT P		2003-4221-9100-001	<b>370,56 €</b>
KFTF-ECATP LCD	0 ... 100 % r. H. (default) 0 ... 80 g / kg (MV) 0 ... 80 g / m <sup>3</sup> (a.F.) 0 ... 85 kJ / kg (ENT.) -20 ... +80 °C (TP)	-35 ... +80 °C	EtherCAT P	<input type="checkbox"/> <input checked="" type="checkbox"/>	2003-4222-9100-001	<b>414,61 €</b>

**Note:** Cable connection with **M8 plug-in connector** (EtherCATP-encoded)

**ACCESSORIES**

<b>MFT-20-K</b>	<b>Mounting flange, plastic</b> (included in the scope of delivery)	7000-0031-0000-000	<b>9,10 €</b>
<b>SF-K</b>	<b>Plastic sinter filter</b> , Ø 16 mm, L = 35 mm, exchangeable	7000-0050-2310-000	<b>12,25 €</b>
<b>SF-M</b>	<b>Metal sinter filter</b> , Ø 16 mm, L = 32 mm, exchangeable, stainless steel <b>V4A</b> (1.4404)	7000-0050-2200-100	<b>40,31 €</b>

For further information, see last chapter Accessories!





Pressure measuring transducer for differential pressure and volume flow,  
incl. connection kit, Bluetooth-enabled,  
with EtherCATP port

Networkable pressure measuring transducer **PREMASGARD® 612x-EtherCATP** (series) with M8 plug-in connector (EtherCATP-encoded), Bluetooth-enabled, in an impact-resistant plastic housing with quick-locking screws, optionally with /without display and bar graph, nozzles for pressure hose (Ø 6mm), incl. connection kit **ASD-06** (2m connecting hose, two pressure port nipples, screws).

The on-wall sensor is used to measure positive, negative or differential pressure in clean air and gaseous media as well to calculate volume flows using the K-factor with function selection. The piezoresistive measuring element is temperature-compensated and guarantees a high degree of reliability and accuracy. The sensor is factory-calibrated.

It is used in the clean room, medical and filter technology, ventilation and air conditioning ducts, spray booths, large-scale catering facilities, for filter monitoring and level measurement or for triggering frequency converters. In case of direct solar irradiation, we recommend using our weather and sun protection hood **WS03** (accessory).

**EtherCATP-enabled measuring transducer** for industrial requirements with maximum reliability: includes easy PLC integration using the device's ESI configuration file, diagnostics (such as communication failure counter), advanced settings options, access to historical data (min / max) and establishing the sensor's service interval. Optionally with large illuminated display (3-line, customised programming in the 7-segment and dot-matrix range) and bar graph (7-digit, LEDs freely configurable) for graphical display, e.g., as a traffic light indicator.

PREMASGARD® 612x-ECATP



EtherCATP  
Cable connection and  
LED status display

**TECHNICAL DATA**

Power supply:	24VDC via EtherCATP (U <sub>S</sub> )
Power consumption:	< 3W
Bus protocol:	<b>EtherCAT</b>
Radio technology:	<b>Bluetooth</b> (LE)
Type of pressure:	Differential pressure [Pa], volume flow [m <sup>3</sup> /h]
Pressure port:	With nozzles for pressure hose Ø 6mm
Measuring range, pressure:	<b>-500... +500 Pa</b> or <b>-7000...+7000 Pa</b> depending on the device type, see table
Pressure accuracy:	<b>Type 6128</b> (500 Pa): typically ± 3 Pa at +25°C <b>type 6127</b> (7000 Pa): typically ± 35 Pa at +25°C compared to the calibrated reference device
Positive / negative pressure:	max. ± 50 kPa
Medium:	Clean air and non-aggressive, non-combustible gases
Parts in contact with media:	Brass, Ni, Duroplast, Si, epoxy, RTV, BSG, UV silicone gel
Media temperature:	-20...+50°C (temperature-compensated 0...+50°C)
Hysteresis:	0.3% of final value
Linearity:	< ± 1% of final value
Temp. drift values:	± 0.1% / °C
Long-term stability:	± 1% per year
Housing:	Plastic, UV-resistant, polyamide material, 30% glass-globe reinforced, with quick-locking screws (slotted / Phillips head combination), colour traffic white (similar to RAL 9016), enclosure cover for display is transparent!
Dimensions:	126 x 90 x 50mm (Tyr 2)
Cable connection:	<b>M8 plug-in connector</b> , EtherCATP-encoded
Permitted humidity:	< 95% r. H., non-precipitating air
Protection class:	III (according to EN 60 730)
Protection type:	<b>IP 54</b> (according to EN 60 529) when built-in
Standards:	CE conformity, according to EMC Directive 2014 / 30 / EU, according to RED 2014 / 53 / EU
Equipment:	<b>Display with illumination</b> , 3-line, customised programming, cutout approx. W51 x H29mm, to display the actual pressure or a customised display value. <b>Bar graph</b> , 7-digit, LEDs freely configurable, to graphically display the reading.

**ACCESSORIES** See table

Display screen Reading **xx-ECATP Tyr 2**



Differential pressure



Volume flow rate

Programmable display screen **xx-ECATP Tyr 2**





**NEW**

S+S REGELTECHNIK

PREMASGARD® 612x-EtherCAT P

Pressure measuring transducer for differential pressure and volume flow,  
incl. connection kit, Bluetooth-enabled,  
with EtherCAT port



Dimensional drawing

PREMASGARD® 612x-ECATP

M8-plug-in connector  
EtherCAT P - encoded

PREMASGARD® 612x-ECATP  
with display and bar graph

Dimensional drawing

**ASD-06**  
Connection set

Dimensional drawing

**ASD-07**  
Connection nipple

Dimensional drawing

**DAL-01**  
Pressure outlet

**ASD-06**  
Connection set

**ASD-07**  
Connection nipple

**DAL-01**  
Pressure outlet

Pressure measuring transducer for differential pressure and volume flow,  
incl. connection kit, Bluetooth-enabled,  
with EtherCAT port

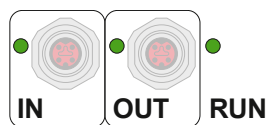

**WS-03**  
Weather and sun protection hood,  
(optional)



EtherCAT P	LED status display
<b>1. LED</b>	<b>"IN"</b>
off	no connection to upstream EtherCAT module
illuminated	LINK: connection to upstream EtherCAT module
blinking	ACT: communication with upstream EtherCAT module
<b>2. LED</b>	<b>"OUT"</b>
off	no connection to downstream EtherCAT module
illuminated	LINK: connection to downstream EtherCAT module
blinking	ACT: communication with downstream EtherCAT module
<b>3. LED</b>	<b>"RUN"</b>
off	EtherCAT module is in "Init" state
quickly blinking	EtherCAT module is in "Pre-Operational" state
slowly blinking	EtherCAT module is in "Safe-Operational" state
illuminated	EtherCAT module is in "Operational" state
<b>The status LEDs are next to the cable connection.</b>	

Mounting diagram

PREMASGARD® 612x-ECATP

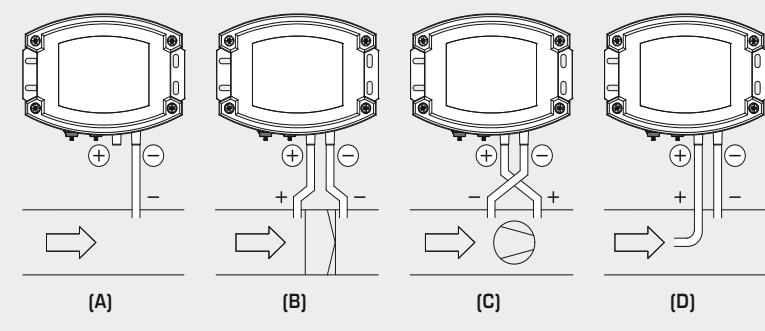

**TYPES OF MONITORING:**

The pressure connections are on the housing with P1 (+) for higher pressure and P2 (-) for lower pressure.

- (A) Below-atmospheric pressure**  
P1 (+) is not connected, but open to the atmosphere  
P2 (-) connected to inside of duct
- (B) Filter**  
P1 (+) connected upstream of filter  
P2 (-) connected downstream of filter
- (C) Ventilator**  
P1 (+) connected downstream of ventilator  
P2 (-) connected upstream of ventilator
- (D) Volume flow**  
P1 (+) dynamic pressure, connected in flow direction  
P2 (-) static pressure, connected free of dynamic pressure components

**Conversion table for pressure values:**

Unit =	bar	mbar	Pa	kPa	mWS
1 Pa	0,00001 bar	0,01 mbar	1 Pa	0,001 kPa	0,000101971 mWS
1 kPa	0,01 bar	10 mbar	1000 Pa	1 kPa	0,101971 mWS
1 bar	1 bar	1000 mbar	100000 Pa	100 kPa	10,1971 mWS
1 mbar	0,001 bar	1 mbar	100 Pa	0,1 kPa	0,0101971 mWS
1 mWS	0,0980665 bar	98,0665 mbar	9806,65 Pa	9,80665 kPa	1 mWS





**NEW**

S+S REGELTECHNIK

**PREMASGARD® 612x-EtherCAT P**

Pressure measuring transducer for differential pressure and volume flow, incl. connection kit, Bluetooth-enabled, with EtherCAT port

**PREMASGARD® 612x-ECATP**  
with display and bar graph



**PREMASGARD® 612x-EtherCAT P** Pressure measuring transducer for differential pressure and volume flow, with EtherCAT port

Type / WG02	Measuring Range / Readout Pressure	Output	Bar graph Display	Item No.	Price
<b>Type 6128</b>	<b>- 500...+ 500 Pa</b>				
PREMASGARD 6128-ECATP	-500...+ 500 Pa	EtherCAT P		2004-6271-9100-011	<b>345,85 €</b>
PREMASGARD 6128-ECATP LCD	-500...+ 500 Pa	EtherCAT P	<input type="checkbox"/> <input checked="" type="checkbox"/>	2004-6272-9100-011	<b>389,90 €</b>
<b>Type 6127</b>	<b>- 7000...+ 7000 Pa</b>				
PREMASGARD 6127-ECATP	-7000...+ 7000 Pa	EtherCAT P		2004-6271-9100-001	<b>345,85 €</b>
PREMASGARD 6127-ECATP LCD	-7000...+ 7000 Pa	EtherCAT P	<input type="checkbox"/> <input checked="" type="checkbox"/>	2004-6272-9100-001	<b>389,90 €</b>
<b>Note:</b>	Cable connection with <b>M8 plug-in connector</b> (EtherCATP-encoded)				

**ACCESSORIES**

<b>ASD-06</b>	<b>Connection set (included in the scope of delivery)</b> , consisting of 2 connection nipples (straight) made of ABS, 2 m PVC hose (soft, UV-resistant) and 4 screws	7100-0060-3000-000	<b>7,28 €</b>
<b>ASD-07</b>	<b>2 connection nipples</b> (at 90° angle) made of ABS	7100-0060-7000-000	<b>7,28 €</b>
<b>DAL-01</b>	<b>Pressure outlet</b> for ceiling or in-wall installation (e.g. in clean rooms)	7300-0060-3000-001	<b>34,07 €</b>
<b>WS-03</b>	<b>Weather and sun protection hood</b> , 200 x 180 x 150 mm, stainless steel <b>V2A</b> (1.4301)	7100-0040-6000-000	<b>42,61 €</b>

For further information, see last chapter Accessories!

↑ BUS

↑ BUS

↑

↑

↑

↑

↑

↑

↑

↑



## Modbus

Against the background of rapidly increasing energy costs, the centralised measurement, monitoring, and control of power consumption in buildings is also becoming increasingly important. The networking of our Modbus-compatible temperature, moisture, pressure and VOC, CO<sub>2</sub> and fine dust (PM) measuring transducers leads to comprehensive energy efficiency and therefore saves money.

### APPLICATION RANGE

- > Industrial and commercial facility automation
- > Central energy management in public and private facilities, such as hospitals, administration centers, schools and museums
- > Measurement and control of temperature, humidity, pressure and air quality parameters in poorly accessible or remote areas



## THERMASGARD®, HYGRASGARD®, PREMASGARD® & AERASGARD®

056 – 161

BUS

### Room control units, Room sensors Room controller with Touchscreen

<b>RYMASKON® 200</b>	Room control units, on-wall	<b>087</b>
<b>RYMASKON® 400</b>	Room controller, on-wall	<b>085</b>
<b>RYMASKON® 500</b>	Room controller, on-wall	<b>NEW 083</b>
<b>RYMASKON® 600</b>	Room controller, on-wall	<b>NEW 079</b>
<b>RYMASKON® 700</b>	Room control units, on-wall	<b>NEW 075</b>
<b>RFTF-Modbus-xx</b>	Room control units, on-wall	<b>089</b>
<b>RTM 1-Modbus</b>	Room sensor, on-wall	<b>091</b>
<b>RFTM-CO2-Modbus-P</b>	Room control units, on-wall	<b>147</b>
<b>FSFTM-Modbus</b>	Room sensors and	
<b>FSFTM-Modbus-P</b>	Room control units, in-wall	<b>113</b>
<b>FSFTM-CO2-Modbus</b>	Room sensors and	
<b>FSFTM-CO2-Modbus-P</b>	Room control units, in-wall	<b>149</b>

### Air quality sensor VOC / CO2 / fine dust sensors (PM)

<b>FSFTM-CO2-Modbus</b>	In-wall sensor	<b>149</b>
<b>RFTM-LQ-PS-CO2-Modbus</b>	Room sensor	<b>NEW 147</b>
<b>AFTM-LQ-CO2-Modbus</b>	On-wall sensor	<b>153</b>
<b>KFTM-LQ-CO2-Modbus</b>	Duct sensor	<b>157</b>

Multifunctional sensor for humidity and temperature and air quality (VOC), fine dust (PM) and CO2 content

### Special accessories

<b>powerIO®</b>	Installation system	<b>NEW 067</b>
<b>MODKON® LA-Modbus</b>	Line termination device	<b>159</b>
<b>MODKON® KA2-Modbus</b>	Communication adapter	<b>161</b>
see chapter Accessories		<b>636</b>

### Temperature sensors

<b>RTM 1-Modbus</b>	Room temperature sensor	<b>091</b>
<b>RPTM 1-Modbus-T3</b>	Pendulum room temperature sensor	<b>107</b>
<b>RPTM 2-Modbus-T3</b>	Pendulum room temperature sensor	<b>109</b>
<b>HFTM-Modbus-T3</b>	Sleeve sensor with cable	<b>101</b>
<b>ALTM 1-Modbus-T3</b>	Surface-contact temperature sensor	<b>103</b>
<b>ALTM 2-Modbus-T3</b>	Surface-contact temperature sensor with cable	<b>105</b>
<b>ATM 2-Modbus-T3</b>	Outside temperature sensor	<b>093</b>
<b>TM 65-Modbus-T3</b>	Duct / immersion / screw-in sensor	<b>095</b>
<b>MWTM-Modbus-T3</b>	Mean value temperature sensor	<b>099</b>

### Humidity sensors

<b>FSFTM-Modbus</b>	In-wall humidity and temperature sensor	<b>113</b>
<b>RFTF-Modbus</b>	Room humidity and temperature sensor	<b>111</b>
<b>RPFTF-Modbus-T3</b>	Room humidity and temperature sensor	<b>119</b>
<b>VFTF-Modbus-T3</b>	Showcase humidity and temperature sensor	<b>121</b>
<b>AFTF-Modbus-T3</b>	On-wall humidity and temperature sensor	<b>115</b>
<b>KFTF-Modbus-T3</b>	Duct humidity and temperature sensor	<b>117</b>
<b>TW-Modbus-T3</b>	Dew point sensor	<b>125</b>

### Pressure sensors

<b>PREMASGARD® 232x-Modbus-T3</b>	Pressure measuring transducer	<b>129</b>
<b>PREMASGARD® 714x-Modbus</b>	Measuring transducer for differential pressure and volume flow	<b>NEW 133</b>
<b>PREMASGARD® 724x-Modbus</b>	Measuring transducer for differential pressure and volume flow (2 channels)	<b>NEW 139</b>
<b>PREMASGARD® 814x-Modbus</b>	Duct humidity and temperature sensor with pressure measuring transducer	<b>143</b>



## Modbus-Capable Measuring Transducers for multi-functional requirements

### Broad Spectrum

All Modbus-compatible S+S temperature, pressure, and humidity sensors are designed to be multifunctional. This reduces the diversity of types and expands their possible applications. Thanks to microprocessor technology, almost any measuring range can be represented, including custom specifications.

### Optimum Precision

All devices are developed, manufactured and tested in accordance with the latest criteria. Each sensor is precisely re-adjustable using offset potentiometers. Take advantage of our experience, our development, manufacturing and product know-how and order these products directly from the manufacturer.

#### Technical Data

- > Galvanic isolation of the RS485 Modbus interface
- > Integrated selectable bus termination resistance
- > Display with backlighting and freely configurable
- > Offset adjustment with potentiometer
- > Temperature resolution: 16 bit AD converter, 0.1 K resolution
- > Measuring range: -50 to +150 °C
- > Accuracy: typically  $\pm 0.2K$  at +25 °C
- > Power supply: 15...36V DC; 24V AC  $\pm 20\%$
- > All devices programmable and addressable even when not energized

#### Certified Quality



Our development and production in Nuremberg/Germany is certified by TÜV Thüringen according to DIN EN ISO 9001:2015.



GOST certified



EAC certified

#### Approved Safety



RoHS conforming materials



ESD compliant manufacturing



CE compliance tested by external laboratories

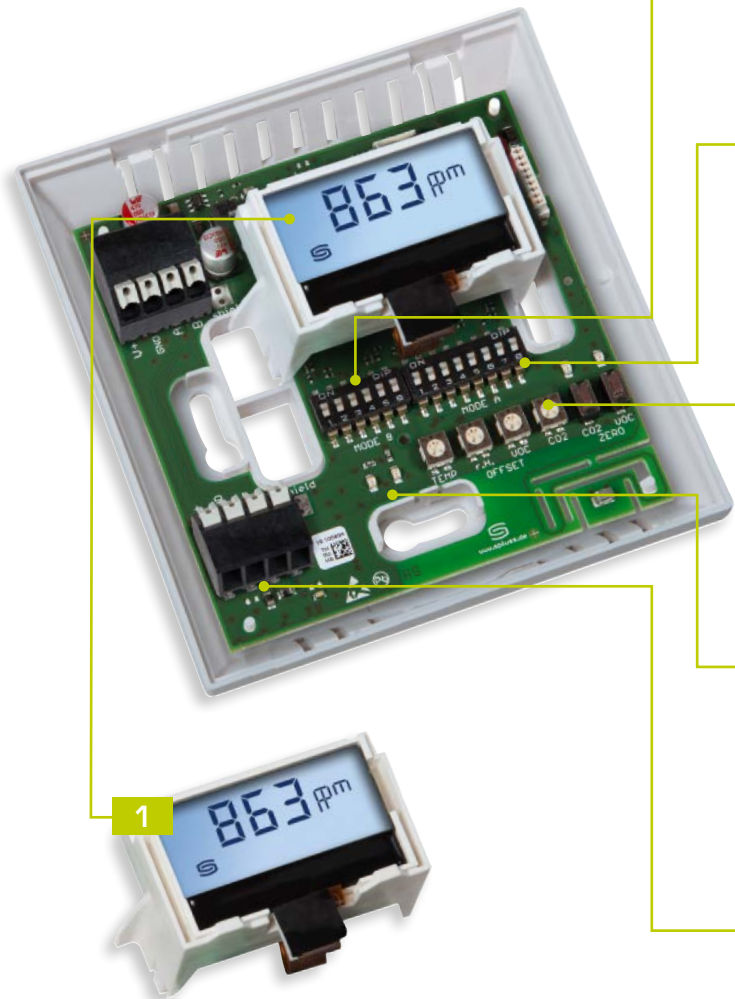

1

### Illuminated Display

With backlighting as well as freely configurable 7/14 segment and 40-point matrix for display of individual measured values

2

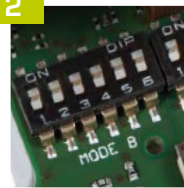

### DIP Switches für Busparameter

Easy configuration of bus parameters: baud rate, parity, parity check and bus termination

3

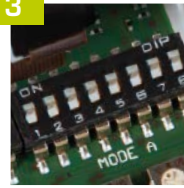

### DIP Switches for Bus Address

Up to 247 addresses possible, address can be configured even when the device is not energized

4



### Offset Potentiometer

For fine adjustment (zero point offset) and readjustment upon recalibration

5



### LED for Telegram Indication

(Green for Receive, Red for Error) Permits fast bus communication diagnosis

6



### Bus Terminals

Push-in terminals (2x) for I/O



S+S TECHNOLOGY FOR SMART BUILDINGS

**Bus address (DIP A)**  
in binary format



DIP switch [A] for setting the bus address:

Bus address (binary coded, value selectable from 1 to 247)							
DIP 1	DIP 2	DIP 3	DIP 4	DIP 5	DIP 6	DIP 7	DIP 8
128	64	32	16	8	4	2	1
ON	ON	OFF	OFF	OFF	OFF	OFF	ON

Example shows  
128 + 64 + 1 = 193  
as Modbus address.

DIP switch

1	00000000	51	00000000	101	00000000	151	00000000	201	00000000
2	00000000	52	00000000	102	00000000	152	00000000	202	00000000
3	00000000	53	00000000	103	00000000	153	00000000	203	00000000
4	00000000	54	00000000	104	00000000	154	00000000	204	00000000
5	00000000	55	00000000	105	00000000	155	00000000	205	00000000
6	00000000	56	00000000	106	00000000	156	00000000	206	00000000
7	00000000	57	00000000	107	00000000	157	00000000	207	00000000
8	00000000	58	00000000	108	00000000	158	00000000	208	00000000
9	00000000	59	00000000	109	00000000	159	00000000	209	00000000
10	00000000	60	00000000	110	00000000	160	00000000	210	00000000
11	00000000	61	00000000	111	00000000	161	00000000	211	00000000
12	00000000	62	00000000	112	00000000	162	00000000	212	00000000
13	00000000	63	00000000	113	00000000	163	00000000	213	00000000
14	00000000	64	00000000	114	00000000	164	00000000	214	00000000
15	00000000	65	00000000	115	00000000	165	00000000	215	00000000
16	00000000	66	00000000	116	00000000	166	00000000	216	00000000
17	00000000	67	00000000	117	00000000	167	00000000	217	00000000
18	00000000	68	00000000	118	00000000	168	00000000	218	00000000
19	00000000	69	00000000	119	00000000	169	00000000	219	00000000
20	00000000	70	00000000	120	00000000	170	00000000	220	00000000
21	00000000	71	00000000	121	00000000	171	00000000	221	00000000
22	00000000	72	00000000	122	00000000	172	00000000	222	00000000
23	00000000	73	00000000	123	00000000	173	00000000	223	00000000
24	00000000	74	00000000	124	00000000	174	00000000	224	00000000
25	00000000	75	00000000	125	00000000	175	00000000	225	00000000
26	00000000	76	00000000	126	00000000	176	00000000	226	00000000
27	00000000	77	00000000	127	00000000	177	00000000	227	00000000
28	00000000	78	00000000	128	00000000	178	00000000	228	00000000
29	00000000	79	00000000	129	00000000	179	00000000	229	00000000
30	00000000	80	00000000	130	00000000	180	00000000	230	00000000
31	00000000	81	00000000	131	00000000	181	00000000	231	00000000
32	00000000	82	00000000	132	00000000	182	00000000	232	00000000
33	00000000	83	00000000	133	00000000	183	00000000	233	00000000
34	00000000	84	00000000	134	00000000	184	00000000	234	00000000
35	00000000	85	00000000	135	00000000	185	00000000	235	00000000
36	00000000	86	00000000	136	00000000	186	00000000	236	00000000
37	00000000	87	00000000	137	00000000	187	00000000	237	00000000
38	00000000	88	00000000	138	00000000	188	00000000	238	00000000
39	00000000	89	00000000	139	00000000	189	00000000	239	00000000
40	00000000	90	00000000	140	00000000	190	00000000	240	00000000
41	00000000	91	00000000	141	00000000	191	00000000	241	00000000
42	00000000	92	00000000	142	00000000	192	00000000	242	00000000
43	00000000	93	00000000	143	00000000	193	00000000	243	00000000
44	00000000	94	00000000	144	00000000	194	00000000	244	00000000
45	00000000	95	00000000	145	00000000	195	00000000	245	00000000
46	00000000	96	00000000	146	00000000	196	00000000	246	00000000
47	00000000	97	00000000	147	00000000	197	00000000	247	00000000
48	00000000	98	00000000	148	00000000	198	00000000		
49	00000000	99	00000000	149	00000000	199	00000000		
50	00000000	100	00000000	150	00000000	200	00000000		





**DIP switch [B] for setting bus parameters:**

Baud rate (selectable)	DIP 1	DIP 2	Parity (selectable)	DIP 3	Parity check (on/off)	DIP 4	8N1 mode (on/off)	DIP 5	Bus termination (on/off)	DIP 6
9600 baud	ON	OFF	EVEN (numbered)	ON	Active (1 stop bit)	ON	Active	ON	Active	ON
19200 baud	ON	ON	ODD (numbered)	OFF	Inactive (no parity) (2 stop bits)	OFF	Inactive (default)	OFF	Inactive	OFF
38400 baud	OFF	ON								
Reserved	OFF	OFF								

**Configuration**

**BUS ADDRESS**

The device address in the range of **1 to 247** is set at DIP switch [A].  
For switch positions 1 to 8 see the table on the back!

Address 0 is reserved for broadcast messages. Addresses greater than 247 must not be assigned and are ignored by the device.  
The DIP switches are binary-coded with the following values:

- DIP 1 = 128 ..... DIP 1 = ON
- DIP 2 = 64 ..... DIP 2 = ON
- DIP 3 = 32 ..... DIP 3 = OFF
- DIP 4 = 16 ..... DIP 4 = OFF
- DIP 5 = 8 ..... DIP 5 = OFF
- DIP 6 = 4 ..... DIP 6 = OFF
- DIP 7 = 2 ..... DIP 7 = OFF
- DIP 8 = 1 ..... DIP 8 = ON

The switch positions shown here result in the Modbus address **128 + 64 + 1 = 193**

**BUS PARAMETERS**

The baud rate (speed of transmission) is set at DIP switches 1 and 2 of DIP switch block [B].  
Selectable are **9600 baud**, **19200 baud**, or **38400 baud** – see table!

**Parity** is set at DIP switch 3 of DIP switch block [B].  
Selectable are **EVEN** or **ODD** – see table!

**Parity check** is activated via DIP switch 4 of DIP switch block [B].  
Selectable are **active (1 stop bit)**, or **inactive (2 stop bits)**, i.e. no parity check – see table!

The **8N1 mode** is activated via DIP switch 5 of DIP switch block [B].  
The functionality of DIP switch 3 (parity) and DIP switch 4 (parity check) of DIP switch block [B] is therefore deactivated.  
Selectable are **8N1 active** or **inactive (default)** – see table!.

**Bus termination** is activated via DIP switch 6 of DIP switch block [B].  
Selectable are **active** (bus termination resistance of 120 Ohm), or **inactive** (no bus termination) – see table!

When bus parameters and bus address are changed at devices with **display**,  
the respective settings are shown on the display for approx. 30 seconds.

**COMMUNICATION INDICATOR**

Communication is indicated via two LEDs.  
Error-free received telegrams are signaled by the green LED lighting up, regardless of the device address.  
Faulty telegrams or triggered Modbus exception telegrams are depicted by the red LED lighting up.

**DIAGNOSTICS**

An error diagnostic function is integrated.

**Display (Baldur)**

Symbols and display examples



**Alternative parameters**

Display programmable via index



**Display (Tyr 2)**

Symbols and display examples



**Individually programmable display area  
for two or three-line displays**

Our displays can be controlled via the Modbus interface.  
This means that messages such as those from the PLC can also be displayed.

All characters in the display can be individually described both  
in the 7-segment area, and in the dot matrix area.

Depending on the device type, it is also possible to display  
alternative parameters such as absolute humidity, dew point, mixture ratio  
or enthalpy instead of the standard display.

**Display (Tyr 3)**

Symbols and display examples



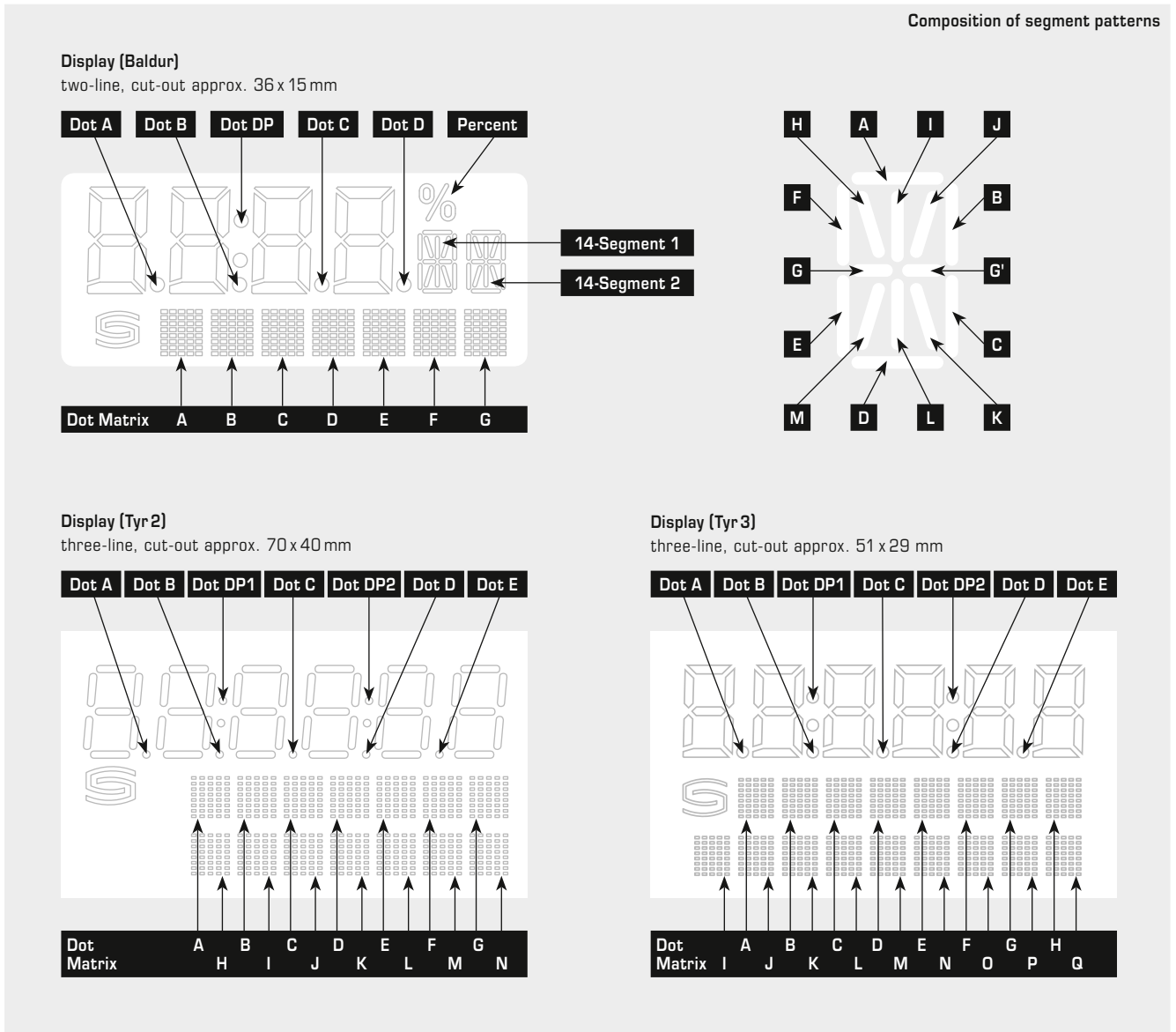

**Representable characters in the dot matrix display area  
for two- and three-line displays**

ASCII characters or control characters are displayed as spaces.

ASCII	Sign	ASCII	Sign	ASCII	Sign	ASCII	Sign	ASCII	Sign	ASCII	Sign	ASCII	Sign
32	Blank	48	0	63	?	78	N	94	^	109	m	124	
33	!	49	1	64	@	79	O	95	_	110	n	125	}
34	"	50	2	65	A	80	P	96	\	111	o	129	ü
35	#	51	3	66	B	81	Q	97	a	112	p	132	ä
36	\$	52	4	67	C	82	R	98	b	113	q	142	Ä
37	%	53	5	68	D	83	S	99	c	114	r	148	ö
38	&	54	6	69	E	84	T	100	d	115	s	153	Ö
40	[	55	7	70	F	85	U	101	e	116	t	154	Ü
41	]	56	8	71	G	86	V	102	f	117	u	223	°
42	*	57	9	72	H	87	W	103	g	118	v		
43	+	58	:	73	I	88	X	104	h	119	w		
44	,	59	;	74	J	89	Y	105	i	120	x		
45	-	60	<	75	K	90	Z	106	j	121	y		
46	.	61	=	76	L	91	[	107	k	122	z		
47	/	62	>	77	M	93	]	108	l	123	{		



General layout of bus structure

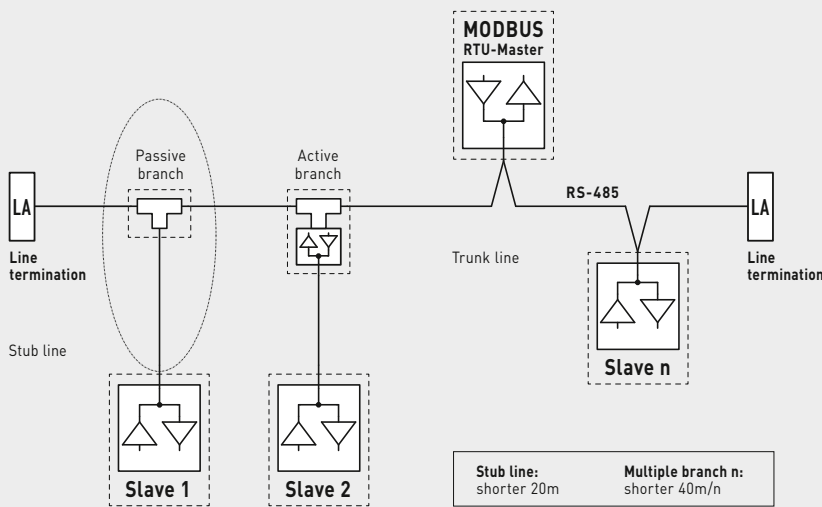

Bus topology with terminating and bias resistors

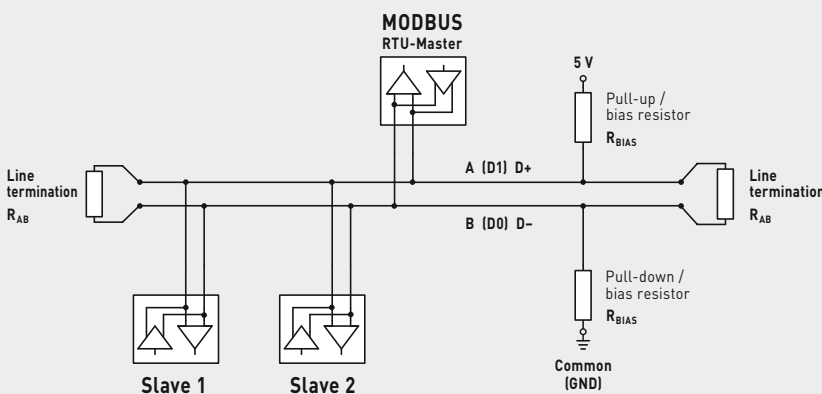

Terminating resistor may only be installed at the ends of the bus line.  
 In networks with repeaters not more than two line terminations are allowed.  
 Line termination at the device can be activated via DIP switch 6.  
 The bias resistors for bus level definition in the resting state are usually activated at the Modbus master / repeater.

The maximum number of subscribers per Modbus segment is 32 devices.  
 When the number of subscribers is greater, the bus must be subdivided into several segments separated by repeaters. The subscriber address can be set from 1 to 247.

For the bus line, a twisted-pair cable data line / power supply line and copper mesh wire shield must be used. Therefore, the line capacitance should be less than 100 pF/m (e.g. Profibus cable).

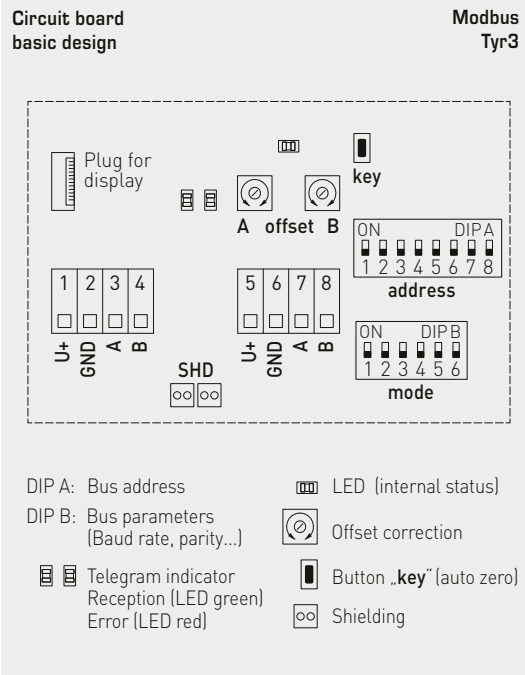

TECHNICAL DATA	
Power supply:	24 V AC (± 20 %) and 15...36 V DC
Power consumption:	< 2 W / 24 V DC < 3,5 VA / 24 V AC
Electrical connection:	see schematic diagram 0.2 - 1.5 mm <sup>2</sup> , via push-in terminals
<b>Bus parameters:</b>	<b>can be configured and addressed via DIP switches in the absence of current delivery (under currentless conditions)</b>
Bus interface:	RS485, <b>galvanically isolated</b> , Bus termination activatable via DIP switches. Up to 32 devices possible in one segment. In case of a greater number of devices, RS485 transceivers must be used.
Bus protocol:	Modbus (RTU mode), address range 0... <b>247</b> selectable
Baud rate:	9600, 19200, 38400 Baud
Status indicator:	LED green = Telegram valid LED red = Telegram error
Display:	The Modbus interface allows the display to be <b>individually</b> configured both in the 7-segment area and in the dot-matrix area.



Building automation is used to control heating, ventilation and air conditioning equipment. The powerIO®-System provides more efficient control, better monitoring and more reliable operational management than previous conventional systems. And does this independently of control system providers.

The installation system has outstanding compatibility with all sensors and actuators from leading manufacturers, and can be enhanced with all of the popular protocols. The system mainly consists of three parts:

### powerIO®-Line

A hybrid cable which transmits data via Ethernet (TCP/IP, 100 Mbit/s) and also power (230 V). This makes it possible to transmit data and provide sensors and actuators with power over long distances with a single cable.

### powerIO®-Box

The powerIO®-Line connects the powerIO®-Boxes. Several communicative sensors and actuators can be connected over short distances with standardised industrial M12 plug-in connections with the boxes.



### Control in accordance with IEC 61131-3

You can optionally create a CODESYS® controller from any powerIO®-Box and use HLK libraries from [www.hvac-automation.com](http://www.hvac-automation.com)

### powerIO®-App

The app turns your Smartphone into a measuring device. This gives you control over the communicative sensor system. You can start up and test devices independently of the manufacturer. Manual intervention and various service functions can be carried out using the Bluetooth connection or via WLAN.



Download the powerIO®-App

[www.powerio.com/app](http://www.powerio.com/app)

### OVERVIEW OF THE ADVANTAGES:

**Easy connection** of the systems thanks to standardised M12 plug-in connectors. The error quota is reduced. A practical aid in times of skill shortages!

**Fewer problems** with interfaces. Coordination problems (cable installations, among other things) between electrical systems and measuring and control equipment are a thing of the past.

**More reliability** during operational management due to preventive messages. Optimum for predictive maintenance.

**More information content** can be transmitted. Ideal for communicative devices and intelligent sensors. Makes better system optimisation and monitoring possible.

**Powerful**, also for large systems.

And long distances can also be achieved due to the 230 V powerIO®-Line.

## powerIO® System

Type / WG02!	Description	(Parts No.)	Item No.	Price
<b>Starter set</b>				
	<b>powerIO®-Starter Set</b>	(T1.Z121)	3PIO-1502-0000-000	<b>1652,40 €</b>
	1 x (T1.B100) powerIO®-Box			
	1 x (T1.S110) powerIO®-Start Unit			
	1 x (T1.L100) powerIO®-Line, 20 m			
	1 x (T1.Z109) Installation cable, 5 m			
	1 x (T1.Z104) M12 connecting cable, 2 m			
	1 x (T1.Z105) M12 connecting cable, 5 m			
	1 x (T1.Z106) M12 connecting cable, 10 m			
	1 x (T1.Z107) M12 connecting cable, 2 m			
	1 x (T1.Z114) M12 flange connector, front-of-wall mounting			
	1 x (T1.Y200) powerIO®-Y distributor			
	1 x (T1.D100) powerIO®-Bluetooth Dongle			

Note: Only one starter set is available per customer. Product is not discountable.

**COST-EFFECTIVE**

Reduction of cabling and cabinets by up to 70%

**FLEXIBLE**

Open system for easy and fast expansion

**DEPENDABLE**

Better control, higher safety, fewer connection faults, more data



**powerIO®-Box**

Decentralised automation box  
Serial to TCP conversion



**powerIO®-Line**

Hybrid cable for transmitting data  
(Ethernet TCP/IP, 100 Mbit/s) and power (230V)

2x 230V / 6 A outputs





WLAN / Bluetooth  
service port

Plug-in location for  
expansion cards

4x RS485  
M12, 5-pin plug-in connections  
with 24V power supply and bus

**powerIO® System**

Type / WG02I	Description	(Parts No.)	Item No.	Price
<b>Main components</b>				
	<p><b>powerIO®-Box</b> Decentralised automation box 230V voltage supply, Ethernet communication, Gateway functionn 2x 230V outputs up to 6 A 4x M12 coupling, A-coded for RS485 connections incl. 24V/2A DC voltage supply (ports 1 to 6) 1x optional plug-in location (port 5) 1x M12 service interface for commissioning with Smartphone app incl. shield terminal, Ethernet, fine fuse (4 A). Dimensions 180 x 255 x 64 mm (W x H x D) (plus cable lead-in and M12 ports) Can be extended with a CODESYS® runtime licence and HVAC libraries.</p>	(T1.B100)	3PIO-1101-0000-000	1652,40 €
	<p><b>powerIO®-Line</b> Hybrid cable for connecting the powerIO®-Boxes Sold by the metre, minimum ordering quantity 10m Data: 2 x (2 x 0,34 mm<sup>2</sup>), shielded Power: 3 x 4,00 mm<sup>2</sup></p>	(T1.L100)	3PIO-1201-0000-000	15,44 €/m
	<p>Power: 3 x 2,50 mm<sup>2</sup></p>	(T1.L200)	3PIO-1203-0000-000	15,01 €/m
	<p><b>powerIO®-Start Unit</b> Switch, allows connection of up to 3x powerIO®-Lines and 2x RJ45 Ethernet cables (e.g. for control, touch panel or network) Top-hat rail installation for switch cabinet or sub-distributor 4TE housing / dimensionsn 72 x 90 x 65 mm (B x H x T)</p>	(T1.S110)	3PIO-1102-0000-000	286,42 €

See next page for more information and accessories.

powerIO® System

Type / WG02I	Description	(Parts No.)	Item No.	Price
<b>Expansion components</b>				
	<p><b>powerIO®-Rio1</b></p> <p>Expansion box for non-communicative sensors / actuators</p> <p>6x Digital input 1x Analogue input 0–10V 1x Analogue input, passive (PT1000) 3x Digital outputs pot.-free (I<sub>max</sub> 16A) 4x Digital outputs 24V/0.5A 1x Analogue outputs 0–10V</p> <p>Each output with manual override (switch/potentiometer). Addressable using rotary switch. Connected via Modbus RTU. Dimensions 160 x 140 x 83 mm (W x H x D)</p>	(T1.R100)	3PIO-1104-0100-000	439,54 €
	<p><b>powerIO®-Rio 4DI</b></p> <p>Digital input modules for the activation of messages (24V)</p> <p>4x Digital input with counting function 24 V AC/DC power supply Connection via Modbus RTU Housing protection class IP67 Dimensions 160 x 140 x 81 mm (W x H x D)</p>	(T1.R100-4DI)	3PIO-1104-0300-000	134,40 €
	<p><b>powerIO®-Rio 8DI</b></p> <p>8x Digital input with counting function (any other design as above)</p>	(T1.R100-8DI)	3PIO-1104-0400-000	143,21 €
	<p><b>powerIO®-Hub</b></p> <p>Distributor for hybrid cable powerIO®-Line</p> <p>Input terminals for power and Ethernet CAT6 hybrid cable with shield terminals, output terminals for 2x power and Ethernet CAT 6, hybrid cable with shield terminals HUB functionality for Ethernet CAT6 distribution via connection to "Ethernet" additional card at powerIO®-Box. Dimensions 160 x 140 x 83 mm (W x H x D)</p>	(T1.H100)	3PIO-1106-0000-000	187,27 €
	<p><b>powerIO®-Booster</b></p> <p>Power output amplification on 24V end</p> <p>Input U = 230V AC Output U = 24V DC / I = 2A 2x M12 connectors each with 24V DC outlet and Modbus RTU Dimensions 160 x 140 x 81 mm (W x H x D)</p>	(T1.R350)	3PIO-1105-0000-000	219,22 €
	<p><b>powerIO®-HK Distributor</b></p> <p>for controlling thermal drives (such as underfloor heating circuit distributor or concrete core heating distributor)</p> <p>8x Digital output 2x Digital input 2x Passive analog input PT1000</p> <p>Modbus RTU using M12, 5-pin, A-coded plug connections. Suitable for installation on distributors. Dimensions 327 x 74 x 66 mm (W x H x D)</p>	(T1.R300)	3PIO-1110-0000-000	384,46 €
	<p><b>powerIO®-Y Distributor Box</b></p> <p>Distributor box for connection of 2 RS485 nodes per port (1-4) to the powerIO® box</p> <p>Bridged bus and voltage, Connection terminals with lever (5x 3-pin / up to 4.00 mm<sup>2</sup>), Connection is established (see below for type) via cable gland and/or M12 socket Dimensions 85 x 85 x 51 mm (W x H x D)</p>			
	2x cable gland	(T1.Y100)	3PIO-1107-0100-000	27,54 €
	1x cable gland	(T1.Y200)	3PIO-1107-0200-000	42,96 €
	1x M12 socket, 5-pin, A-coded			
	2x M12 socket, 5-pin, A-coded	(T1.Y300)	3PIO-1107-0300-000	58,38 €

**powerIO® System**

Type / WG02I	Description	(Parts No.)	Item No.	Price
--------------	-------------	-------------	----------	-------

<b>Service Tool</b>				
	<p><b>powerIO®-Bluetooth Dongle</b></p> <p><b>Communication with powerIO®-App</b></p> <p>For plugging into service port of the powerIO®-Box. For commissioning/servicing the sensors/actuators.</p>	(T1.D100)	3PIO-1103-0000-000	<b>218,12 €</b>

**BSK modules**



	<p><b>powerIO®-BSK ECO</b></p> <p><b>Fire damper module for 1 fire damper (24 V or 230 V), without galvanic isolation (ECO)</b></p> <p>2x digital input 1x digital output relay 230 V/5 A 24 V AC/DC power supply Connection via Modbus RTU BSK connection via AMP socket Housing protection class <b>IP 54</b> Dimensions 110 x 110 x 66 mm (W x H x D)</p>	(T1.BSK1-AMP-24-ECO)	3PIO-1108-0100-000	<b>112,36 €</b>
	<p>BSK connection via terminal blocks Housing protection class <b>IP67</b> (any other design as above)</p>	(T1.BSK1-24-ECO)	3PIO-1108-0200-000	<b>112,36 €</b>

	<p><b>powerIO®-BSK 24</b></p> <p><b>Fire damper module for 2 fire dampers (24 V or 230 V), with galvanic isolation</b></p> <p>4x Digital input 2x Digital output relay 230 V / 16 A 24 V AC/DC power supply Connection via Modbus RTU BSK connection via AMP socket Housing protection class <b>IP 54</b> Dimensions 160 x 140 x 81 mm (W x H x D)</p>	(T1.BSK2-AMP-24)	3PIO-1108-0300-000	<b>158,63 €</b>
	<p>BSK connection via terminal blocks Housing protection class <b>IP67</b> (any other design as above)</p>	(T1.BSK2-24)	3PIO-1108-0400-000	<b>158,63 €</b>

	<p><b>powerIO®-BSK 230</b></p> <p><b>Fire damper module for 2 fire dampers ( 230 V), with galvanic isolation</b></p> <p>4x Digital input 2x Digital output relay 230 V / 16 A 230 V AC power supply Connection via Modbus RTU BSK connection via AMP socket Housing protection class <b>IP 54</b> Dimensions 160 x 140 x 81 mm (W x H x D)</p>	(T1.BSK2-AMP-230)	3PIO-1108-0500-000	<b>167,44 €</b>
	<p>BSK connection via terminal blocks Housing protection class <b>IP67</b> (any other design as above)</p>	(T1.BSK2-230)	3PIO-1108-0600-000	<b>167,44 €</b>







powerIO® System











Type / WG02I	Description	(Parts No.)	Item No.	Price
<b>Expansion cards powerIO®-Box T1</b>				
 	<b>Expansion card "Ethernet"</b> M12, 4-pin D-coded Allows connection of an M12 Ethernet cable (T1.Z102). Incorporation of other IP subscribers with up to 100 Mbit/s.	(T1.C100-ETH)	3PIO-1301-0000-000	<b>218,12 €</b>
	<b>Expansion card "RS485"</b> M12, 5-pin A-coded Extends port 5 with an RS485 COM port. With 24 V on M12 pins as output voltage.	(T1.C100-RS485-24)	3PIO-1302-0000-000	<b>218,12 €</b>
	<b>Expansion card "RS232"</b> M12, 5-pin A-coded Extends port 5 with an RS232 COM port. With 24 V on M12 pins as output voltage.	(T1.C100-RS232-24)	3PIO-1303-0000-000	<b>286,42 €</b>

Installation board powerIO®-Box T1

	<b>Installation board</b> Simple preinstallation for electrical installation, 4 threaded bolts for screwing on the powerIO®-Box (series T1) at a later date. Aluminium installation board with cut-out for installation to pipes using lashing straps.	(T1.Z119)	3PIO-1403-0000-000	<b>57,28 €</b>
	<b>Installation board with magnets</b> Simple preinstallation for electrical installation, 4 threaded bolts for screwing on the powerIO®-Box (series T1) at a later date. Aluminium installation board with pre-installed magnets for attaching to air ducts, for example.	(T1.Z125)	3PIO-1404-0000-000	<b>80,42 €</b>

powerIO® Accessories

Type / WG02	Description	(Parts No.)	Item No.	Price	
<b>Connecting cable</b>					
	<b>M12 connecting cable</b> PVC cable, shielded, 5-pin, A-coded, M12 connector <-> open end	(ALG)	<b>ALG M12-A5M PVC xx</b>		
			<b>2 m</b>	2000-9141-0100-011	<b>29,82 €</b>
			<b>5 m</b>	2000-9141-0100-021	<b>37,71 €</b>
			<b>10 m</b>	2000-9141-0100-031	<b>50,38 €</b>
	<b>M12 connecting cable</b> PVC cable, shielded, 5-pin, A-coded, M12 connector <-> M12 socket	(VLG)	<b>VLG M12-A5 PVC xx</b>		
			<b>2 m</b>	2000-9111-0000-031	<b>56,21 €</b>
			<b>5 m</b>	2000-9111-0000-041	<b>63,68 €</b>
			<b>10 m</b>	2000-9111-0000-051	<b>76,47 €</b>
	<b>M12 Ethernet cable</b> M12 connector, 4-pin, D-coded <-> RJ45 connector Ethernet cable for direct connection to the powerIO®-"Ethernet" expansion card	(T1.Z102)	3PIO-1601-0000-000	<b>79,32 €</b>	
			<b>M12 installation cable</b> PVC cable, shielded, 5-pin (5 x 0.25 mm <sup>2</sup> ), open ended, same colour code as M12 cable Sold by the metre, minimum ordering quantity 10 m	(T1.Z109)	3PIO-1202-0000-000

powerIO® Accessories				
Type / WG02	Description	(Parts No.)	Item No.	Price
<b>Connection accessories</b>				
	<b>M12-Y-distributor</b> M12, 5-pin, A-coded, 1x connector → 2x sockets For connecting two M12 connectors to one M12 socket. Bus and voltage are available at both connections. Can be plugged directly into the powerIO®-Box for connecting two sensors / actuators. Length 300 mm	(T1.Z122)	3PIO-1602-0000-000	<b>62,79 €</b>
	<b>M12-Y-adapter</b> M12, 5-pin, A-coded. 1x socket / 1x connector → 1x connector	(T1.Z110)	3PIO-1603-0000-000	<b>44,06 €</b>
	<b>M12 coupling</b> M12, 5-pin, A-coded, 1x socket unassembled	(T1.Z111)	3PIO-1604-0000-000	<b>15,87 €</b>
	<b>M12 connector</b> M12, 5-pin, A-coded, 1x connector unassembled	(T1.Z112)	3PIO-1605-0000-000	<b>14,63 €</b>
	<b>M12 flange coupling VWM</b> M12, 5-pin, A-coded. 1x socket for front-of-wall mounting	(T1.Z113)	3PIO-1607-0000-000	<b>16,52 €</b>
	<b>M12 flange connector VWM</b> M12, 5-pin, A-coded, 1x connector for front-of-wall mounting	(T1.Z114)	3PIO-1608-0000-000	<b>17,63 €</b>
	<b>M12 flange coupling HWM</b> M12, 5-pin, A-coded. 1x socket for rear-wall mounting	(T1.Z115)	3PIO-1609-0000-000	<b>16,52 €</b>
	<b>M12 flange connector HWM</b> M12, 5-pin, A-coded, 1x connector for rear-wall mounting	(T1.Z116)	3PIO-1610-0000-000	<b>16,52 €</b>
	<b>M12 protection cap</b> Protection cap for unused M12 sockets	(T1.Z117)	3PIO-1606-0000-000	<b>3,30 €</b>
	<b>Ethernet connector</b> Connector for the powerIO®-Line to the powerIO®-Box or powerIO®-Start Unit (included in scope of delivery of the powerIO®-Box)	(T1.Z101)	3PIO-1402-0000-000	<b>9,91 €</b>
	<b>Shield terminal</b> for connecting the shield of the powerIO®-Line to the powerIO®-Box (included in scope of delivery of the powerIO®-Box)	(T1.Z100)	3PIO-1401-0000-000	<b>7,71 €</b>

**Interface for controlling  
temperature, ventilation, sun protection (2 zones),  
room control unit with colour touch display,  
with Modbus or BACnet connection**

The RYMASKON® 500 / 600 / 700 series of room control units are designed for controlling the climatic zone in residential, hotel and office rooms and individually regulate the heating/cooling steps of the internal rooms. A colour touch display with modern icons is used for the visual display and operation at the location. The product range is characterised by the variety of combination options of the individual components.

The RYMASKON® 700 Interface series controls via the bus heating or cooling valves, fan speed and the sun protection (blinds, shutters) in two zones. In addition to the integrated temperature sensor, two external temperature sensors (NTC10K) can also be connected. Measuring elements for relative humidity and CO<sub>2</sub> are also available. The devices are used in room climate technology, including convective fans, cooling ceilings and heating/cooling systems. Wall mounting is performed on standard in-wall flush boxes. The devices are optionally available with a Modbus or BACnet communication interface and in various type versions (see number key).

The basic model RYMASKON® 710 Interface with colour touch display (3.5"), in a white housing, possesses an integrated temperature and humidity sensor (CO<sub>2</sub> sensor optional), 2 resistance inputs (NTC10K) for external sensors, 1 digital input, 1 relay output (7 A / 0.5 A with CO<sub>2</sub>) and optionally with Modbus or BACnet connection. The room control units are used for controlling temperature, fans and sun protection (2 zones) via the bus.

#### TECHNICAL DATA (Basic model)

Device type:	room control unit
Functions:	temperature and fans (1 zone), sun protection (2 zones)
Communication:	<b>Modbus RTU Slave</b> address range can be configured between 1...247 or <b>BACnet MS/TP</b> device ID 65100 (default) and MAC address can be configured between 1...247 RS485 interface, max. 63 devices, 9500 / 19200 / 38400 / 57500 / 76800 Baud, none / even / odd parity, 1 / 2 stop bits
Voltage supply:	24 V AC/DC (± 15%)
Power consumption:	max. 1.92 W
Inputs:	2 resistance inputs (NTC10K) for external temperature sensors 1 digital input (potential-free), impedance <1 kOhm
Outputs:	1 relay output (2-point regulation) without CO <sub>2</sub> : 7 A at 230 V AC (resistive load); 2.2 / 1.3 A at 230 / 115 V AC (inductive load) with CO <sub>2</sub> : 0.5 / 0.5 A at 230 / 115 V AC (resistive/inductive load)
Operating mode:	Comfort, ECO, OFF, Boost
Control element:	<b>3.5" touch display</b> with backlighting, cut-out approx. 50 x 75 mm, resolution 320 x 480 pixels, 255,000 colours

#### TEMPERATURE

Sensor:	integrated temperature sensor
Measuring range:	-40...+125 °C
Accuracy:	typically ±0.5 °C at +25 °C

#### HUMIDITY

Sensor:	integrated humidity sensor
Measuring range:	0...100% r.H.
Accuracy:	typically ±2% r.H. (20...80% r.H.) at +25 °C

#### CARBON DIOXIDE (CO<sub>2</sub>)

Sensor:	optical NDIR sensor (non-dispersive infrared technology), with automatic calibration
Measuring range:	0...5000 ppm
Accuracy:	typically ±50 ppm ±3% of the measured value at +25 °C
Electrical connection:	0.14 - 1.5 mm <sup>2</sup> , via screw terminals
Housing:	plastic, polycarbonate material, self-extinguishing, white colour (optionally black or chrome), weight approx. 220 g
Housing dimensions:	approx. 88 x 112 x 14.5 mm (on-wall) approx. 88 x 112 x 20.5 mm (on-wall with CO <sub>2</sub> sensor) approx. 52 x 53 x 28.5 mm (in-wall)
Mounting:	wall-mounting on in-wall flush box, Ø55 mm
Ambient temperature:	0...+50 °C (operation); -30...+70 °C (storage)
Permitted humidity:	0...95% r.H., (non-precipitating air)
Protection type:	<b>IP 20</b> (according to EN 60529)
Standards:	CE conformity, according to EMC directive 2004/108/EU, Low-Voltage directive 2006/95/EU, according to EN 61000-6-1/3, EN 60730-1, EN 6100-4-2/4/5/11

#### ACCESSORIES

see table

#### RYMASKON® 700

Display icons



Room temperature  
[°C]



External temperature  
[°C]



Relative humidity  
[%RH]



Ventilation  
(fan speed,  
6 steps)



Sun protection  
(2 zones)

#### RYMASKON® 700

with CO<sub>2</sub> sensor

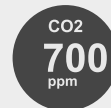

CO<sub>2</sub> content  
[ppm]





**NEW**

S+S REGELTECHNIK

**RYMASKON® 700** Interface

Interface for controlling temperature, ventilation, sun protection (2 zones), room control unit with colour touch display, with Modbus or BACnet connection

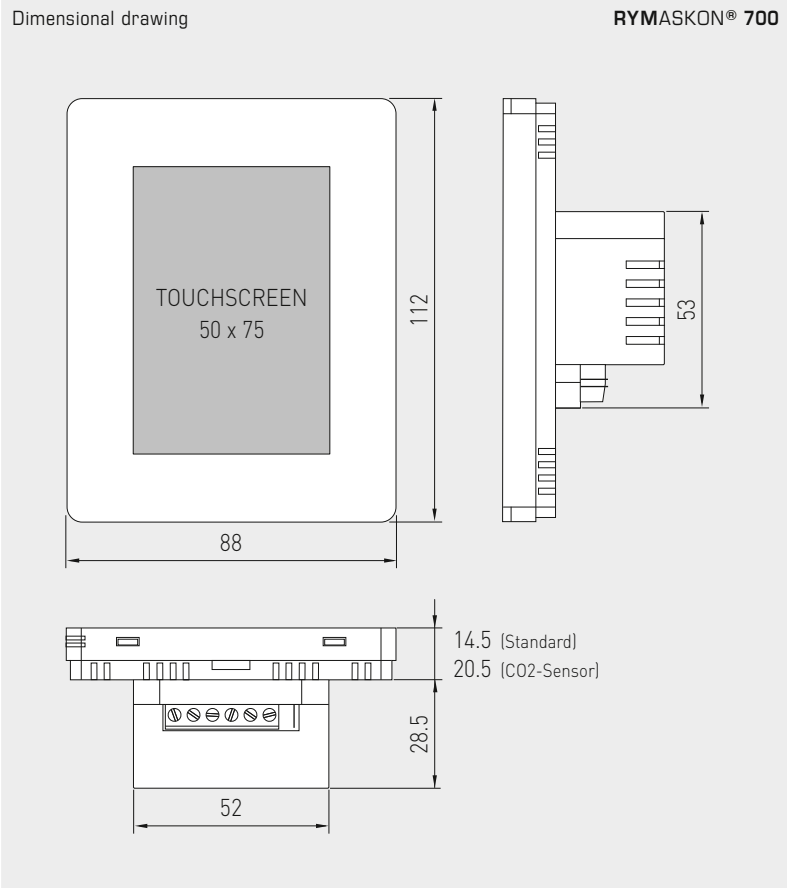

**RYMASKON® 700**  
On-wall 14.5 mm



**RYMASKON® 700**  
with CO2 sensor  
On-wall 20.5 mm

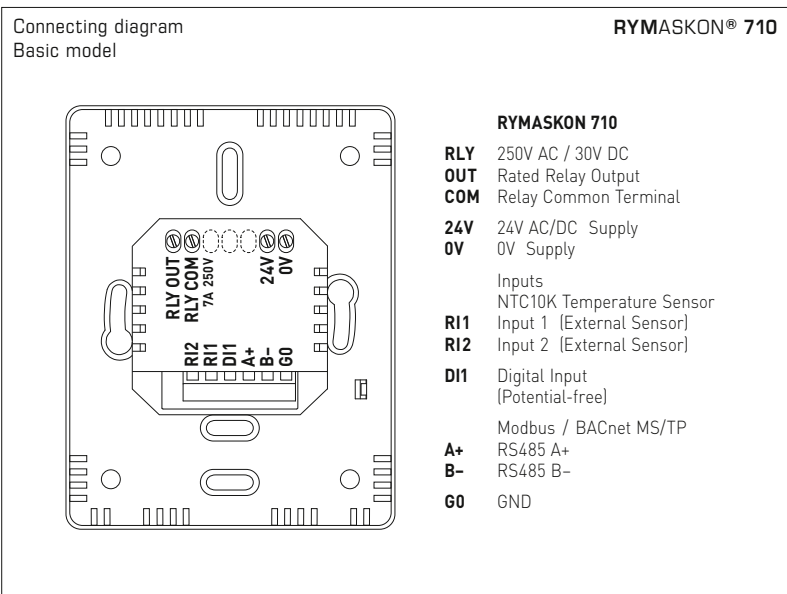

Interface for controlling  
 temperature, ventilation, sun protection (2 zones),  
 room control unit with colour touch display,  
 with Modbus or BACnet connection

**RYMASKON® 700** Interface (series)  
 Number key for type versions

**R Y M 7 - 1 0 I x - x x 0 x - 0 0 0**

- Pos. 1-4 Type name**  
RYMASKON 700
- Pos. 5 Channel configuration**  
Type 710 **2RI, 1DI, 1RO** 7 A / 0.5 A with CO2
- Pos. 7 Device type**  
Interface
- Pos. 8 Communication**  
Modbus  
BACnet
- Pos. 9 Voltage supply**  
12 V DC  
24 V AC/DC
- Pos. 10 Additional measuring elements**  
without \*  
**RH** (rel. humidity)  
**CO2** (carbon dioxide)  
**RH + CO2**
- Pos. 11 Extra options**  
without
- Pos. 12 Housing colour**  
black  
white  
chrome

RYM7 ]

1 ]

I ]

M ]

B ]

1 ]

2 ]

0 ]

1 ]

2 ]

3 ]

0 ]

1 ]

2 ]

3 ]

- Pos. 5 **RI** Resistance input (NTC10K) for external temperature sensors
- DI** Digital input (potential-free)
- RO** Relay output (7 A), (2-point regulation)

Pos. 10 \* The **temperature sensor** forms part of the basic equipment and is included in the option "without" additional measuring elements.

Type 710 **Basic model** (see table on the right) available from stock –  
 Freely configurable type versions available upon request!

RYMASKON® (basic model) Comparison table		Type 510 Thermostat	Type 610 Controller	Type 710 Interface
<b>Outputs</b>	Relay output for heating / cooling	<b>1</b>	–	Bus
	Analogue output (0–10 V) Heating / cooling 6-way valves, fans	–	<b>3</b>	Bus
<b>Function</b>	Sun protection (zones)	●	●●	●●
	Air Conditioning (on/off)	●	–	–
<b>Sensors</b>	Temperature (°C)	●	●	●
	Humidity (% RH)	●	●	●
	CO2 (ppm)	–	○	○
<b>Inputs</b>	Digital input	<b>1</b>	<b>1</b>	<b>1</b>
	Analogue input (0–10 V)	–	<b>2</b>	–
	Resistance input (NTC10K)	<b>2</b>	–	<b>2</b>

○ = optional



**NEW**

S+S REGELTECHNIK

**RYMASKON® 700** Interface

Interface for controlling temperature, ventilation, sun protection (2 zones), room control unit with colour touch display, with Modbus or BACnet connection

**KEY FEATURES**

Basic model

**RYMASKON® 700**

Home Screen

- 24 V AC/DC voltage supply
- 3.5 inch touch display with backlighting
- Modbus or BACnet
- Wall mounting on standard in-wall flush boxes
- Integrated temperature sensor (basic equipment)
- Integrated humidity sensor
- Integrated CO2 sensor (optional)
- Regulation of heating, cooling, fans via the bus
- Operation of temperature, fans and sun protection (2 zones) via touch display
- 2 resistance inputs (NTC10K) for external temperature sensors
- 1 relay output (7A / 0.5A with CO2) as 2-point regulator (potential-free) controllable via bus
- 1 digital input (potential-free)
- Operating mode  
Comfort, ECO, OFF, Boost, Frosts Protection



<b>RYMASKON® 710</b>		Interface (basic model), room control unit with touch display					
Type / WG02	Communi- cation	Measuring element	Control system	Colour	Display	Item No.	Price
<b>RYMASKON® 710-Modbus</b>							
Rymaskon 712-MOD-RH	Modbus	T   RH	T   V   S   S	white	■	RYM7-10IM-2102-000	<b>322,92 €</b>
Rymaskon 712-MOD-RH-CO2	Modbus	T   RH   CO2	T   V   S   S	white	■	RYM7-10IM-2302-000	<b>441,72 €</b>
<b>RYMASKON® 710-BACnet</b>							
Rymaskon 712-BAC-RH	BACnet	T   RH	T   V   S   S	white	■	RYM7-10IB-2102-000	<b>322,92 €</b>
Rymaskon 712-BAC-RH-CO2	BACnet	T   RH   CO2	T   V   S   S	white	■	RYM7-10IB-2302-000	<b>441,72 €</b>
Measuring element / control system:	<b>T</b> = Temperature sensor (basic equipment) <b>RH</b> = Humidity sensor <b>CO2</b> = Carbon dioxide sensor		<b>T</b> = Temperature <b>V</b> = Ventilation <b>S</b> = Sun protection (2 zones)				
Channel configuration:	<b>2RI</b> 2 Resistance inputs (NTC10K) for external temperature sensors <b>1DI</b> 1 digital input (potential-free) <b>1RO</b> 1 Relay output (7 A), (2-point regulation)						
Optional:	<b>More type versions available upon request!</b> For configuration options, see number key (left).						
<b>ACCESSORIES</b>							
<b>RYMASKON® USB Configuration Tool</b>							
RYMASKON USB_CT	For quick transfer of the device configuration from the PC to all devices in the building					1901-51Z3-0002-000	<b>139,32 €</b>



**Controller for controlling and regulating temperature, ventilation, sun protection (2 zones), room control unit with colour touch display, with Modbus or BACnet connection**

The **RYMASKON® 500 / 600 / 700** series of room control units are designed for controlling the climatic zone in residential, hotel and office rooms and individually regulate the heating/cooling steps of the internal rooms. A colour touch display with modern icons is used for the visual display and operation at the location. The product range is characterised by the variety of combination options of the individual components.

The **RYMASKON® 600 Controller** series regulates through analogue outputs (0–10 V) up to two **heating or cooling valves** (6-way valves can also be controlled) and the **ventilation** (EC ventilator). The **sun protection** (blinds, shutters) can be controlled in two zones via the bus. In addition to the integrated temperature sensor, two external temperature sensors (NTC10K) or two analogue sensors (0–10 V) can also be connected. Measuring elements for relative humidity and CO2 are also available. The devices are used in room climate technology, including convector fans, cooling ceilings and heating/cooling systems. Wall mounting is performed on standard in-wall flush boxes. The devices are optionally available with a Modbus or BACnet communication interface and in various type versions (see number key).

The basic model **RYMASKON® 610 Controller** with colour touch display (3.5"), in a white housing, possesses an integrated temperature and humidity sensor (CO2 sensor optional), 2 analogue inputs for external sensors (0–10 V), 1 digital input, 3 analogue outputs (0–10 V), and optionally with Modbus or BACnet connection. The room control units are used for controlling temperature, fans and sun protection (2 zones) directly via the analogue outputs or via the bus.

**TECHNICAL DATA (Basic model)**

Device type:	room control unit with controller
Functions:	temperature and fans (1 zone), sun protection (2 zones)
Communication:	<b>Modbus RTU Slave</b> address range can be configured between 1...247 or <b>BACnet MS/TP</b> device ID 65100 (default) and MAC address can be configured between 1...247 RS 485 interface, max. 63 devices, 9500 / 19200 / 38400 / 57500 / 76800 Baud, none / even / odd parity, 1 / 2 stop bits
Power supply:	24 V AC/DC (± 15%)
Power consumption:	max. 1.92 W
Inputs:	2 analogue inputs 0–10 V 1 digital input (potential-free, Impedance <1 kOhm)
Outputs:	3 analogue outputs 0–10 V (heating, cooling, fans) input impedance > 100 kOhm
Operating mode:	Comfort, ECO, OFF, Boost, Frost Protection
Control element:	<b>3.5" touch display</b> with backlighting, cut-out approx. 50 x 75 mm, resolution 320 x 480 pixels, 255,000 colours

<b>TEMPERATURE</b>	
Sensor:	integrated temperature sensor
Measuring range:	–40...+125 °C
Accuracy:	typically ±0.5 °C at +25 °C

<b>HUMIDITY</b>	
Sensor:	integrated humidity sensor
Measuring range:	0...100% r.H.
Accuracy:	typically ±2% r.H. (20...80% r.H.) at +25 °C

<b>CARBON DIOXIDE (CO2)</b>	
Sensor:	optical NDIR sensor (non-dispersive infrared technology), with automatic calibration
Measuring range:	0...5000 ppm
Accuracy:	typically ±50 ppm ±3% of the measured value at +25 °C
Electrical connection:	0.14–1.5 mm², via screw terminals
Housing:	plastic, polycarbonate material, self-extinguishing, white colour (optionally black or chrome), weight approx. 220 g
Housing dimensions:	approx. 88 x 112 x 14.5 mm (on-wall) approx. 88 x 112 x 20.5 mm (on-wall with CO2 sensor) approx. 52 x 53 x 28.5 mm (in-wall)
Mounting:	wall mounting on in-wall flush box, Ø55 mm
Ambient temperature:	0...+50 °C (operation); –30...+70 °C (storage)
Permitted humidity:	0...95% r.H., (non-precipitating air)
Protection type:	<b>IP 20</b> (according to EN 60 529)
Standards:	CE conformity, according to EMC directive 2004/108/EU, Low-Voltage directive 2006/95/EU, according to EN 61000-6-1/3, EN 60730-1, EN 6100-4-2/4/5/11

**ACCESSORIES** see table

**RYMASKON® 600**  
Display icons



**Room temperature**  
[°C]



**External temperature**  
[°C]



**Relative humidity**  
[%RH]



**Ventilation**  
(fan speed,  
6 steps)



**Sun protection**  
(2 zones)

**RYMASKON® 600**  
with CO2 sensor

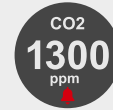
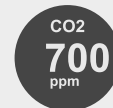

**CO2 content**  
[ppm]

Alarm levels 1/2  
(incl. bell icon)  
configurable



**NEW**

S+S REGELTECHNIK

**RYMASKON® 600** Controller

Controller for controlling and regulating temperature, ventilation, sun protection (2 zones), room control unit with colour touch display, with Modbus or BACnet connection

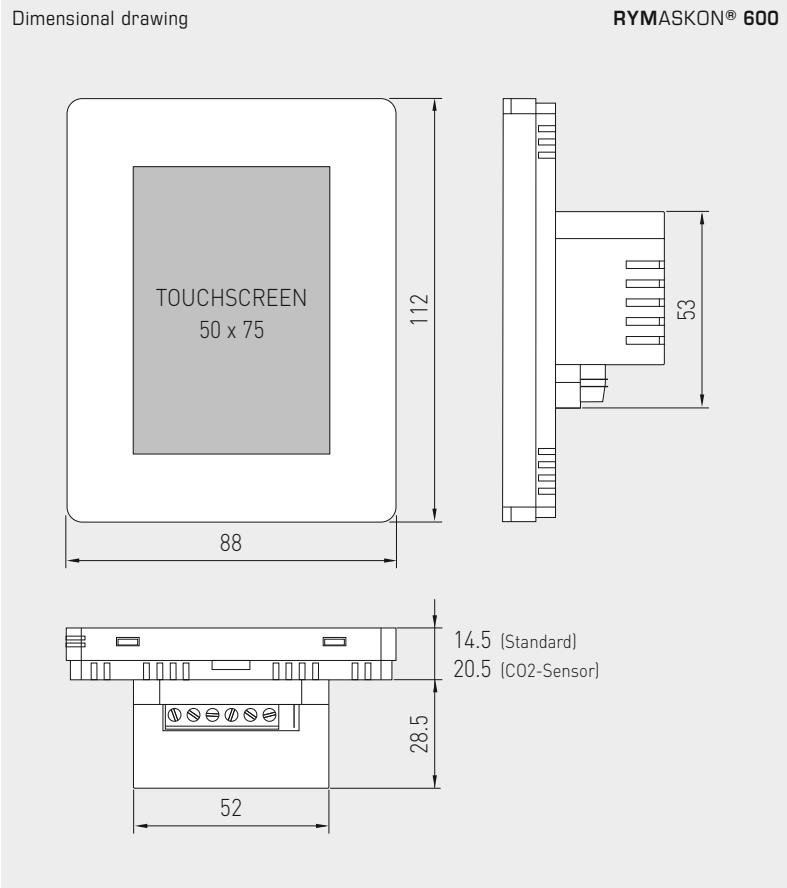

**RYMASKON® 600**  
On-wall 14.5 mm



**RYMASKON® 600**  
with CO2 sensor  
On-wall 20.5 mm

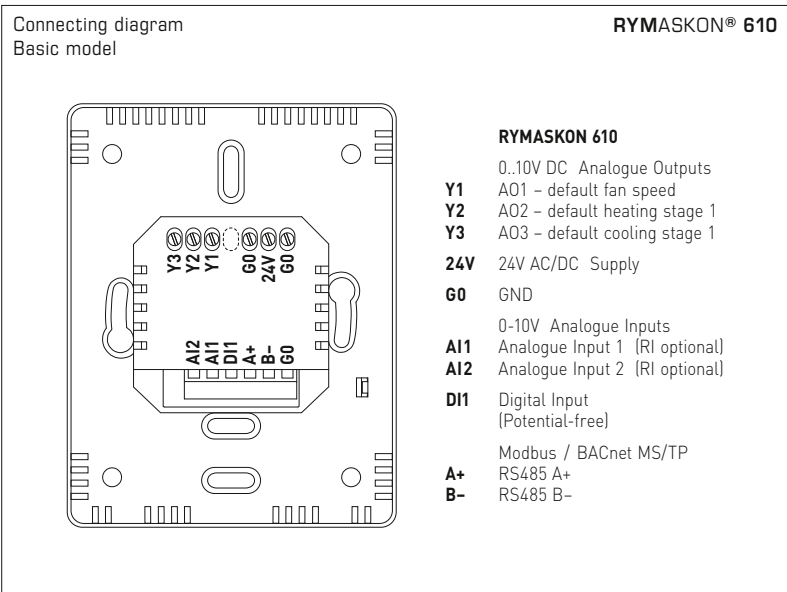

**Controller for controlling and regulating temperature, ventilation, sun protection (2 zones), room control unit with colour touch display, with Modbus or BACnet connection**

**RYMASKON® 600** Controller (series)  
Number key for type versions

**R Y M 6 - x 0 C x - 2 x x x - 0 0 0**

- Pos. 1-4** Type name  
RYMASKON 600
- Pos. 5** Channel configuration  
Type 610 **2RI, 1DI, 3AO** (h,c,f)  
Type 620 **1RI, 1DI, 2AO** (h,c), **3RO** (f) 0.5 A  
Type 630 **1RI, 1DI, 2AO** (h,c), **3RO** (f) 7A  
Type 640 **2RI, 1DI, 1AO** (f), **2DO** (h, c, PMW)  
Type 650 **2RI, 1DI, 1AO** (EC-f), **4RO** (h,c,f) 0.5 A  
Type 660 **2RI, 1DI, 2DO** (h, c, PMW), **3RO** (f) 7 A
- Pos. 7** Device type  
Controller
- Pos. 8** Communication  
Modbus  
BACnet
- Pos. 9** Voltage supply  
24 V AC/DC
- Pos. 10** Additional measuring elements  
without \*  
**RH** (rel. humidity)  
**CO2** (carbon dioxide)  
**RH + CO2**
- Pos. 11** Extra options  
without  
**AI** instead of **RI**
- Pos. 12** Housing colour  
black  
white  
chrome

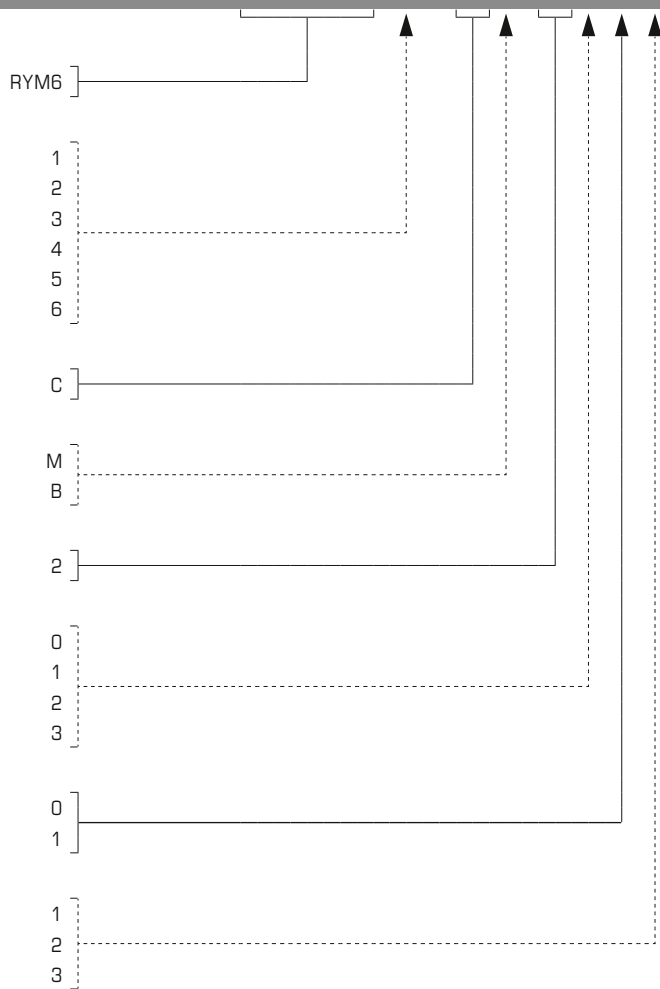

Pos. 5	<b>RI</b> Resistance input (NTC10K)	(h) Heating	Pos. 10 *	The <b>temperature sensor</b> forms part of the basic equipment and is included in the option "without" additional measuring elements.
	<b>RO</b> Relay output (0.5 A / 7 A)	(c) Cooling		
	<b>AI</b> Analogue input (0-10 V DC) instead of <b>RI</b>	(f) Fans		
	<b>AO</b> Analogue output (0-10 V DC)	(EC-f) EC fans		
	<b>DI</b> Digital input (potential-free)	(PMW) Pulse Width Modulation		
	<b>DO</b> Digital output (potential-free)			

Type 610 **Basic model** (see table on the right) available from stock – Freely configurable type versions available upon request!

RYMASKON® (basic model) Comparison table	Type 510 Thermostat	Type 610 Controller	Type 710 Interface
<b>Outputs</b>	Relay output for heating/cooling	1	–
	Analogue output (0-10 V) Heating/cooling 6-way valves, fans	–	3
<b>Function</b>	Sun protection (zones)	●	●●
	Air-conditioning (on/off)	●	–
<b>Sensors</b>	Temperature (°C)	●	●
	Humidity (% RH)	●	●
	CO2 (ppm)	–	○
<b>Inputs</b>	Digital input	1	1
	Analogue input (0-10 V)	–	2
	Resistance input (NTC10K)	2	–

○ = optional





**NEW**

S+S REGELTECHNIK

**RYMASKON® 600** Controller

Controller for controlling and regulating temperature, ventilation, sun protection (2 zones), room control unit with colour touch display, with Modbus or BACnet connection

**KEY FEATURES**

Basic model

**RYMASKON® 600**

Home Screen

- 24 V AC/DC voltage supply
- 3.5 inch touch display with background lighting
- Modbus or BACnet
- Wall mounting on standard in-wall flush boxes
- Integrated temperature sensor (basic equipment)
- Integrated humidity sensor
- Integrated CO2 sensor (optional)
- Regulation of heating, cooling, fans directly through analogue outputs (0–10 V)
- Operation of temperature, fans, sun protection (2 zones) via touch display
- 3 analogue outputs (0–10 V) for controlling heating/cooling valves and EC motor
- 2 analogue inputs (0–10 V) for external sensors
- 1 digital input (potential-free)
- Operating mode  
Comfort, ECO, OFF, Boost, Frosts Protection



<b>RYMASKON® 610</b>		Controller (basic model), room control unit with touch display					
Type / WG02	Communication	Measuring element	Control system	Colour	Display	Item No.	Price
<b>RYMASKON® 610-Modbus</b>							
Rymaskon 612-MOD-RH-AI	Modbus	T   RH	T   V   S   S	white	■	RYM6-10CM-2112-000	<b>376,92 €</b>
Rymaskon 612-MOD-RH-CO2-AI	Modbus	T   RH   CO2	T   V   S   S	white	■	RYM6-10CM-2312-000	<b>538,92 €</b>
<b>RYMASKON® 610-BACnet</b>							
Rymaskon 612-BAC-RH-AI	BACnet	T   RH	T   V   S   S	white	■	RYM6-10CB-2112-000	<b>376,92 €</b>
Rymaskon 612-BAC-RH-CO2-AI	BACnet	T   RH   CO2	T   V   S   S	white	■	RYM6-10CB-2312-000	<b>538,92 €</b>
Measuring element / control system:	<b>T</b> = Temperature sensor (basic equipment) <b>RH</b> = Humidity sensor <b>CO2</b> = Carbon dioxide sensor		<b>T</b> = Temperature <b>V</b> = Ventilation <b>S</b> = Sun protection (2 zones)				
Channel configuration:	<b>2AI</b> 2 analogue inputs (0–10 V DC) instead of <b>2RI</b> <b>1DI</b> 1 digital input (potential-free) <b>3AO</b> 3 analogue outputs (0–10 V DC) for heating, cooling, fans						
Optional:	<b>More type versions available upon request!</b> For configuration options, see number key (left).						
<b>ACCESSORIES</b>							
<b>RYMASKON® USB Configuration Tool</b>							
RYMASKON USB_CT	For quick transfer of the device configuration from the PC to all devices in the building					1901-51Z3-0002-000	<b>139,32 €</b>

**Thermostat for controlling and regulating temperature and the sun protection (1 zone), room control unit with colour touch display, with Modbus or BACnet connection**

The RYMASKON® 500 / 600 / 700 series of room control units are designed for controlling the climatic zone in residential, hotel and office rooms and individually regulate the heating/cooling steps of the internal rooms. A colour touch display with modern icons is used for the visual display and operation at the location. The product range is characterised by the variety of combination options of the individual components.

The RYMASKON® 500 Thermostat series regulates a heating or cooling valve directly through a relay. The sun protection (blinds, shutters) can be controlled in one zone via the bus. In addition to the integrated temperature sensor, two external temperature sensors (NTC10K) can also be connected. A measuring element for relative humidity is also available. The devices are used in room climate technology and heating/cooling systems, such as cooling ceilings and floor heating. Wall mounting is performed on standard in-wall flush boxes. The devices are optionally available with a Modbus or BACnet communication interface (optionally without communication) and in various type versions (see number key).

The basic model RYMASKON® 510 Thermostat with colour touch display (3.5"), in a white housing, possesses an integrated temperature and humidity sensor, 2 resistance inputs (for external NTC10K temperature sensors), 1 digital input, 1 relay output (7A) and optionally with a Modbus or BACnet connection. The room control units are used for controlling heating/cooling directly through the relay (2-point regulation) and the sun protection (1 zone) via the bus.

#### TECHNICAL DATA (Basic model)

Device type:	room control unit with 2-point regulation
Functions:	temperature (1 zone), sun protection (1 zone)
Communication:	<b>Modbus RTU Slave</b> address range can be configured between 1...247 or <b>BACnet MS/TP</b> device ID 65100 (default) and MAC address can be configured between 1...247 RS 485 interface, max. 63 devices, 9500 / 19200 / 38400 / 57500 / 76800 Baud, none / even / odd parity, 1 / 2 stop bits
Power supply:	24 V AC/DC (± 15%)
Power consumption:	max. 1.92 W
Inputs:	2 resistance inputs (NTC10K) for external temperature sensors 1 digital input (potential-free), impedance <1 kOhm
Outputs:	1 relay output (2-point regulation) 7 A at 230 V AC (resistive load); 2.2 / 1.3 A at 230 / 115 V AC (inductive load)
Operating mode:	Comfort, ECO, OFF, Boost, Holiday, Frost Protection
Control element:	<b>3.5" touch display</b> with background lighting, cut-out approx. 50 x 75 mm, resolution 320 x 480 pixels, 255,000 colours

#### TEMPERATURE

Sensor:	integrated temperature sensor
Measuring range:	-40...+125 °C
Accuracy:	typically ±0.5 °C at +25 °C

#### HUMIDITY

Sensor:	integrated humidity sensor
Measuring range:	0...100% r.H.
Accuracy:	typically ±2% r.H. (20...80% r.H.) at +25 °C
Electrical connection:	0.14 - 1.5 mm <sup>2</sup> , via screw terminals
Housing:	plastic, polycarbonate material, self-extinguishing, white colour (optionally black or chrome), weight approx. 220 g
Housing dimensions:	approx. 88 x 112 x 14.5 mm (on-wall) approx. 52 x 53 x 28.5 mm (in-wall)
Mounting:	wall mounting on in-wall flush box, Ø55 mm
Ambient temperature:	0...+50 °C (operation); -30...+70 °C (storage)
Permitted humidity:	0...95% r.H., (non-precipitating air)
Protection type:	<b>IP 20</b> (according to EN 60529)
Standards:	CE conformity, according to EMC directive 2004/108/EU, Low-Voltage directive 2006/95/EU, according to EN 61000-6-1/3, EN 60730-1, EN 6100-4-2/4/5/11

<b>ACCESSORIES</b>	see table
--------------------	-----------

#### RYMASKON® 500

Display icons



Room temperature  
[°C]



External temperature  
[°C]



Relative humidity  
[%RH]



Air Conditioning  
(AC)



Sun protection  
(1 zone)



**NEW**

S+S REGELTECHNIK

**RYMASKON® 500** Thermostat

Thermostat for controlling and regulating temperature and the sun protection (1 zone), room control unit with colour touch display, with Modbus or BACnet connection

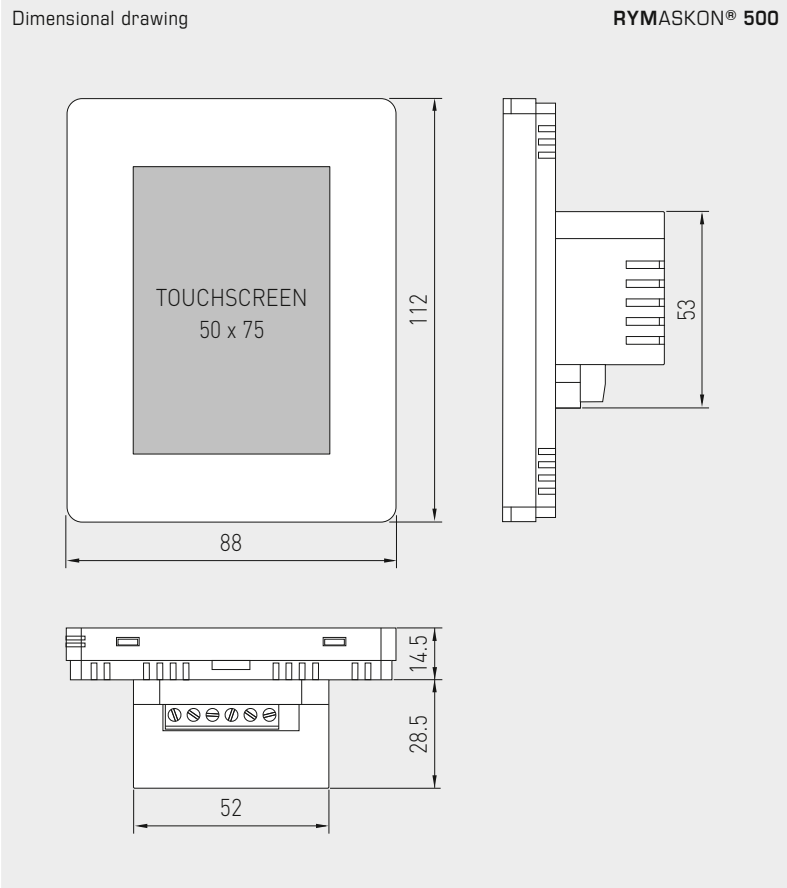

**RYMASKON® 500**  
On-wall 14.5 mm

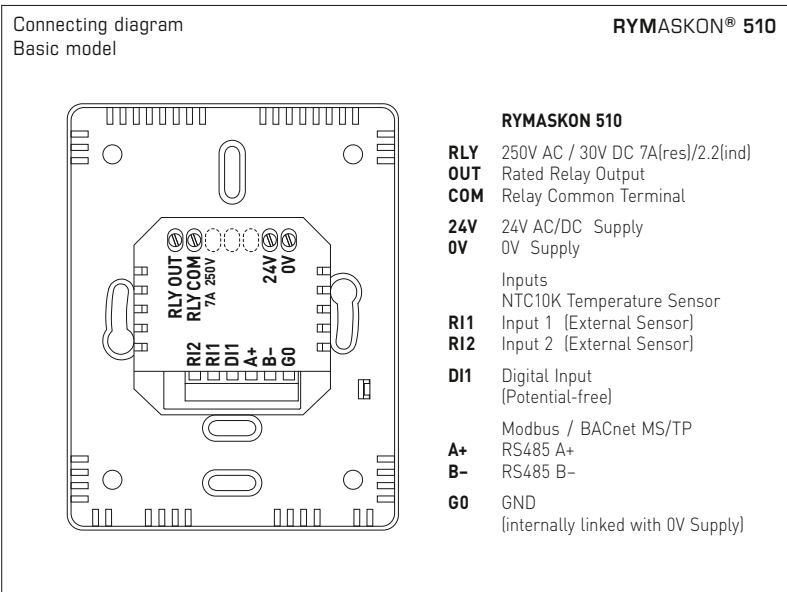



Thermostat for controlling and regulating temperature and the sun protection (1 zone), room control unit with colour touch display, with Modbus or BACnet connection

**RYMASKON® 500** Thermostat (series)  
Number key for type versions

**R Y M 5 - 1 0 T x - x x 0 x - 0 0 0**

- Pos. 1-4 Type name**  
RYMASKON 500
- Pos. 5 Channel configuration**  
Type 510 **2RI, 1DI, 1RO 7A**
- Pos. 7 Device type**  
Thermostat
- Pos. 8 Communication**  
without  
Modbus  
BACnet
- Pos. 9 Voltage supply**  
12 V DC  
24 V AC/DC  
90-250 V AC
- Pos. 10 Additional measuring elements**  
without \*  
**RH** (rel. humidity)
- Pos. 11 Extra options**  
without
- Pos. 12 Housing colour**  
black  
white  
chrome

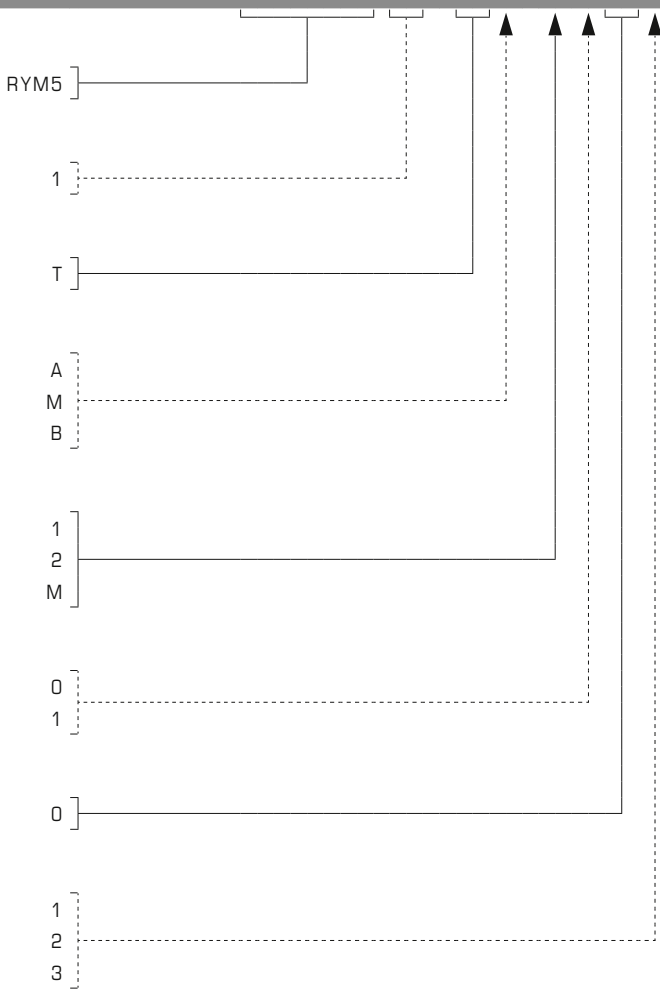

Pos. 5	<b>RI</b> Resistance input (NTC10K) for external temperature sensors <b>DI</b> Digital input (potential-free) <b>RO</b> Relay output (7 A), (2-point regulation)	Pos. 10 *	The <b>temperature sensor</b> forms part of the basic equipment and is included in the option "without" additional measuring elements.
--------	--	-----------	--

Type 510 **Basic model** (see table on the right) available from stock –  
Freely configurable type versions available upon request!

RYMASKON® (basic model) Comparison table	Type 510 Thermostat	Type 610 Controller	Type 710 Interface
<b>Outputs</b>	Relay output for heating/cooling	1	–
	Analogue output (0-10 V) Heating/cooling 6-way valves, fans	–	3
<b>Function</b>	Sun protection (zones)	●	● ●
	Air Conditioning (on/off)	●	–
<b>Sensors</b>	Temperature (°C)	●	●
	Humidity (% RH)	●	●
	CO2 (ppm)	–	○
<b>Inputs</b>	Digital input	1	1
	Analogue input (0-10 V)	–	2
	Resistance input (NTC10K)	2	–

○ = optional



**NEW**

S+S REGELTECHNIK

**RYMASKON® 500** Thermostat

Thermostat for controlling and regulating temperature and the sun protection (1 zone), room control unit with colour touch display, with Modbus or BACnet connection

**KEY FEATURES**

Basic model

**RYMASKON® 500**

Home Screen

- 24 V AC/DC voltage supply
- 3.5 inch touch display with background lighting
- Modbus or BACnet
- Wall mounting on standard in-wall flush boxes
- Integrated temperature sensor (basic equipment)
- Integrated humidity sensor
- Regulation of heating or cooling via relay (2-point regulator)
- Operation of temperature and sun protection (1 zone) via touch display
- 2 resistance inputs (NTC10K) for external temperature sensors
- 1 digital input (potential-free)
- 1 relay output (7 A), (2-point regulation)
- Operating mode  
Comfort, ECO, OFF, Boost, Holiday, Frost Protection



**RYMASKON® 510** Thermostat (basic model), room control unit with touch display

Type / WG02	Communication	Measuring element	Control system	Colour	Display	Item No.	Price
<b>RYMASKON® 510-Modbus</b>							
Rymaskon 512-MOD-RH	Modbus	T   RH	T   S	white	■	RYM5-10TM-2102-000	<b>253,80 €</b>
<b>RYMASKON® 510-BACnet</b>							
Rymaskon 512-BAC-RH	BACnet	T   RH	T   S	white	■	RYM5-10TB-2102-000	<b>253,80 €</b>
Measuring element / control system:	T = Temperature sensor (basic equipment)		T = Temperature heating / cooling				
	RH = Humidity sensor		S = Sun protection (1 zone)				
Channel configuration:	<b>2RI</b> 2 resistance inputs (NTC10K) for external temperature sensors						
	<b>1DI</b> 1 digital input (potential-free)						
	<b>1RO</b> 1 Relay output (7 A), (2-point regulation)						
Optional:	<b>More type versions available upon request!</b> For configuration options, see number key (left).						

**ACCESSORIES**

<b>RYMASKON® USB Configuration Tool</b>							
RYMASKON USB_CT	For quick transfer of the device configuration from the PC to all devices in the building					1901-51Z3-0002-000	<b>139,32 €</b>

Room control unit for room automation, configurable, with multifunctional display and Modbus connection

**RYMASKON®** stands for a series of multifunctional room control units.

The individually configurable **RYMASKON® 400 - Modbus** enables automated monitoring and control of the indoor climate and illumination in a Modbus network. It has two digital inputs and two digital/analogue outputs. Room climate control and regulation can be accessed from a central point on a higher-level Modbus master and on-site operation can be selectively or completely disabled. Thanks to its internal outputs, the inputs and settings on the device do not necessarily have to be processed by the master. This means that it is also possible to have decentralised individual room control at any time. An internal sensor detects the room temperature.

Six freely assignable function buttons on the front panel of the unit can be used for on-site operation and configuration. An integrated rotary encoder with a central input button enables manual adjustment of settings and parameter assignment on location. Desired functions (such as "Light ON") and display values can be activated by triggering an approximation sensor when entering the room.

The dimmable multifunctional display is designed specifically for room operation and uses intuitive symbols for a clear view of all available spatial data. Besides the time, weekday and climate parameters (temperature, humidity, dew point, CO<sub>2</sub> content), it can also display additional features, such as heating/cooling and fan modes, window open, lighting, alarm, key lock or room occupancy.

**RYMASKON® 412-Modbus**  
**RYMASKON® 422-Modbus**



### TECHNICAL DATA

Power supply:	24 V DC (± 10%)
Power consumption:	1.08 W at 100% backlighting 0.94 W at 15% backlighting 0.89 W without backlighting (without load at the actuator outputs)
Inputs:	2 digital inputs without additional 0 V output signal *
Outputs:	Type 410: 2 analogue outputs (0-10 V DC) rated current max. 4 mA Type 420: 2 digital outputs or PWM rated current 400 mA (short circuit max. 1.2 A)
Interface:	RS485 Modbus RTU Slave (57600, 38400, 19200, 9600 Baud), bus termination can be set via DIP switch
Sensor:	NTC 10 kΩ, 0...+70 °C, precision ±0.4 K
Operating elements:	multifunctional display, 6 touch buttons, 1 rotary encoder, 1 approximation sensor (IR)
Electrical connection:	0.14 - 1.5 mm <sup>2</sup> , via plug-in screw terminals
Housing:	plastic, glass front panel, black or white colour
Dimensions:	88 x 173 x 30 mm (incl. connection terminals)
Mounting:	using a plastic mounting plate (see dimensional drawing), wall mounting or on in-wall flush double switch box
Ambient temperature:	+5...+40 °C (operation); -10...+50 °C (storage)
Permitted humidity:	0...85% r. H. (without dew formation)
Protection type:	<b>IP 20</b> (according to EN 60 529)
Standards:	CE-conformity, electromagnetic compatibility according to EN 61 326, EMC Directive 2014 / 30 / EU

#### \* digital inputs (DI1 / DI2)

In order to connect potential-free contacts, a GND signal (e.g. terminal X2.3) should be routed to the desired input via the contact.

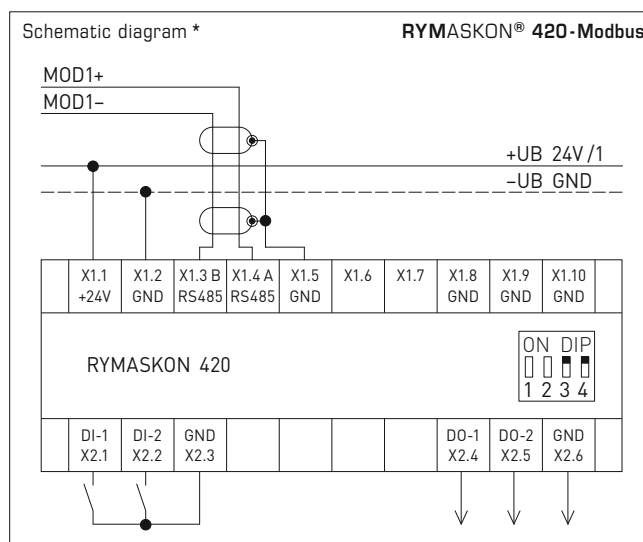
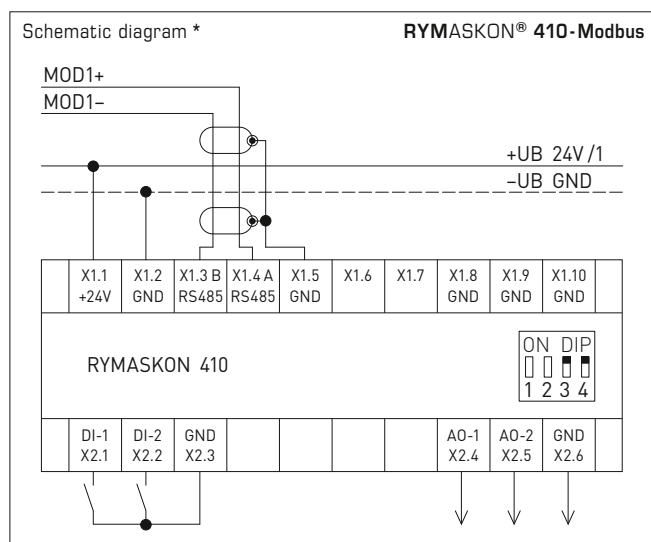



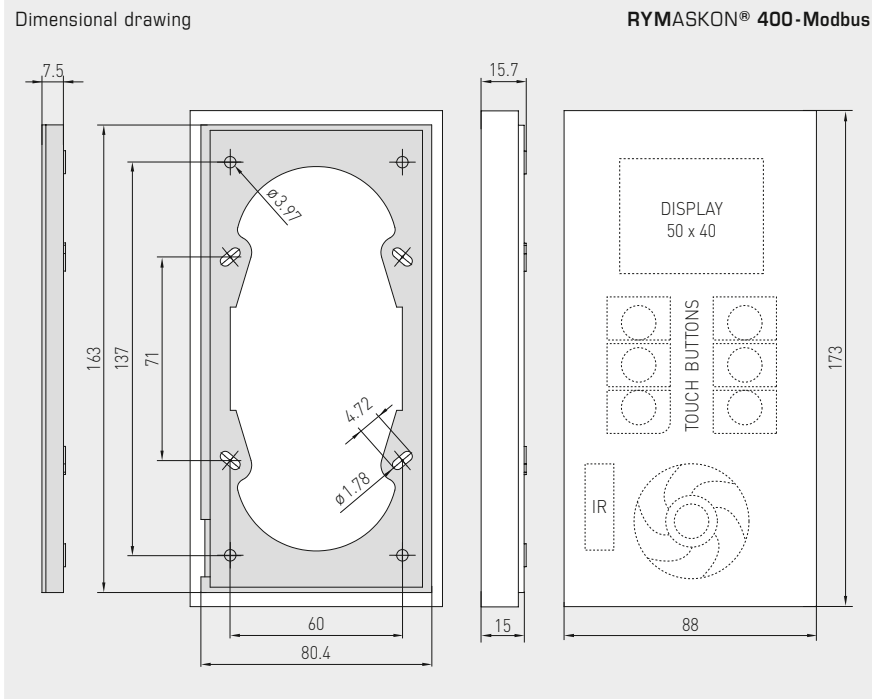

RYMASKON® 411-Modbus  
RYMASKON® 421-Modbus



Display symbols **RYMASKON® 400-Modbus**

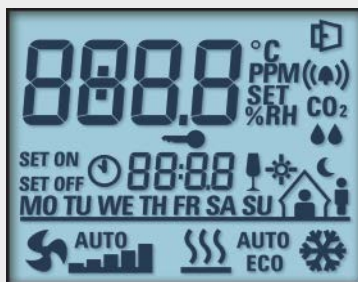

DIP Switch	<b>RYMASKON® 400-Modbus</b>	
<b>RS485 bus termination</b>	<b>DIP 3</b>	<b>DIP 4</b>
activated (default)	ON	ON
deactivated	OFF	OFF
<b>Note:</b> Always configure the bus termination of the RS 485 interface (DIP 3 and DIP 4) in pairs!		

Connecting diagram **RYMASKON® 410-Modbus**

<b>X2</b>		
Input 1	⊙1	DI-1 (digital) 0 V
Input 2	⊙2	DI-2 (digital) 0 V
	⊙3	GND
Output 1	⊙4	AO-1 (analogue) 0-10 V DC
Output 2	⊙5	AO-2 (analogue) 0-10 V DC
	⊙6	GND
<b>X1</b>		
	⊙1	+UB 24 V DC
	⊙2	-UB GND
	⊙3	RS485 - B (Modbus RTU)
	⊙4	RS485 - A (Modbus RTU)
	⊙5	GND
	⊙6	GND
	⊙7	GND
	⊙8	GND
	⊙9	GND
	⊙10	GND

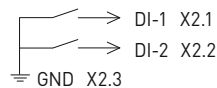

Connecting diagram **RYMASKON® 420-Modbus**

<b>X2</b>		
Input 1	⊙1	DI-1 (digital) 0 V
Input 2	⊙2	DI-2 (digital) 0 V
	⊙3	GND
Output 1	⊙4	DO-1 (digital / PWM)
Output 2	⊙5	DO-2 (digital / PWM)
	⊙6	GND
<b>X1</b>		
	⊙1	+UB 24 V DC
	⊙2	-UB GND
	⊙3	RS485 - B (Modbus RTU)
	⊙4	RS485 - A (Modbus RTU)
	⊙5	GND
	⊙6	GND
	⊙7	GND
	⊙8	GND
	⊙9	GND
	⊙10	GND

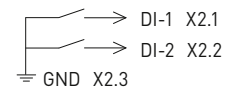

**RYMASKON® 400-Modbus** Room control unit for room automation

Type / WG02	Communication	Output	Colour	Display	Item No.	Price
<b>RYMASKON® 410-Modbus</b>						
RYMASKON 411	RS485	2x (analog) 0-10V	black	■	1901-5121-2101-000	513,77 €
RYMASKON 412	RS485	2x (analog) 0-10V	white	■	1901-5121-2102-000	513,77 €
<b>RYMASKON® 420-Modbus</b>						
RYMASKON 421	RS485	2x (digital / PWM)	black	■	1901-5121-2201-000	513,77 €
RYMASKON 422	RS485	2x (digital / PWM)	white	■	1901-5121-2202-000	513,77 €

PWM = pulse-width modulation

**ACCESSORIES**

<b>KA2-Modbus</b>	Communication adapter (USB/RS485) for system connection	1906-1200-0000-100	203,80 €
<b>LA-Modbus</b>	Line termination device (with terminating resistor) as an active bus termination	1906-1300-0000-100	76,01 €

**Room control unit for room automation, configurable, with multifunctional display and Modbus connection**

**RYMASKON® 200-Modbus**  
Type 232

**RYMASKON®** stands for a series of multifunctional room control units.

The individually configurable **RYMASKON® 200-Modbus** enables automated monitoring and control of the indoor climate and illumination in a Modbus network. It provides three digital inputs and a universal input, which allows connection of up to four external push buttons or switches. It can be configured remotely from a higher-level Modbus master and integrated into a cross-building room climate monitoring and data acquisition system. Internal sensors record room temperature, relative humidity and dew point.

Up to eight capacitive function buttons on the front panel of the compact unit can be used for on-site operation and configuration. A buzzer sounds to acknowledge button use and can also be used as an acoustic fault or alarm warning.

The dimmable multifunctional display is designed specifically for room operation and uses intuitive symbols for a clear view of all available spatial data. Besides the time, date and climate parameters (temperature, humidity, dew point, CO<sub>2</sub> content), it can also display additional features, such as fan mode or room occupancy. The back light colour can be adapted to the room design.



### TECHNICAL DATA

Power supply:	24 V DC (± 10%)
Power consumption:	max. 0.8 W
Inputs:	3 digital inputs (for standard push buttons or switches) 1 universal input (can be configured for connecting NTC10K temperature sensors or as additional digital input for the connection of standard push buttons or switches)
Bus interface:	RS485 Modbus RTU slave (57600, 38400, 19200, 9600 Baud), bus termination can be set via DIP switch, configurable speed 1200-115200 bit/s (typically 57600 bit/s), adjustable transfer mode (typically "8E1", 1 start bit, 8 data bits, even parity, 1 stop bit)
Equipment:	1 NFC (Near Field Communication) 1 infra-red receiver (NEC protocol) 1 buzzer
Operating elements:	1 backlit multifunctional display (individually programmable RGB colour selection) 4 / 6 / 8 touch buttons, type-dependent

### TEMPERATURE

Sensor:	CMOS temperature sensor
Measuring Range:	-40...+125 °C, resolution: 0.1 °C
Accuracy:	typically ±0.5 °C (at +5...+60 °C)

### HUMIDITY

Sensor:	capacitive humidity sensor
Measuring Range:	0...100 % r.H., resolution: 0.1 % r.H.
Accuracy:	typically ±2 % r.H. (at +25 °C, 20...80 % r.H.) typically ±3 % r.H. (at +25 °C, 0...20 % r.H. or 80...100 % r.H.)

Electrical connection:	0.2 - 1.5 mm <sup>2</sup> , via plug-in screw terminals
Housing:	plastic, black or white colour
Dimensions:	approx. 94.5 x 110 x 19.5 mm
Mounting:	using a plastic mounting plate (see dimensional drawing), on in-wall flush box, Ø 55 mm
Ambient temperature:	0...+50 °C (operation)
Permitted humidity:	0...90 % r.H. (without dew formation)
Protection type:	<b>IP 30</b> (according to EN 60 529)
Standards:	CE conformity, electromagnetic compatibility according to EN 50491, EMC directive 2014 / 30 / EU

### CONTROL

Type 210:	Temperature up/down, Room occupancy, Menu
Type 220:	Temperature up/down, Fan speed up/down, Room occupancy, Menu
Type 230:	Temperature up/down, Fan speed up/down, Light on/off, Room occupancy, Menu
Type 240:	Temperature up/down, Sun protection up/down, Light on/off, Room occupancy, Menu
Type 250:	Temperature up/down, Fan speed up/down, Sun protection up/down, Room occupancy, Menu
Type 260:	Temperature up/down, Fan speed up/down, Sun protection up/down, Light, Menu

### ACCESSORIES

see table

Display symbols **RYMASKON® 200-Modbus**



DIP Switch	<b>RYMASKON® 200-Modbus</b>
<b>RS 485 bus termination</b>	<b>DIP 1</b>
activated (default)	<b>ON</b>
deactivated	<b>OFF</b>

Connecting diagram **RYMASKON® 200-Modbus**

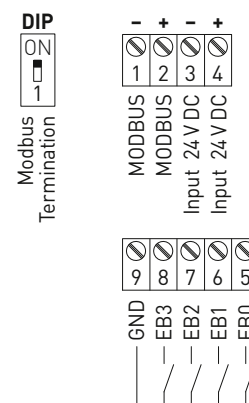



S+S REGELTECHNIK

Room control unit for room automation, configurable, with multifunctional display and Modbus connection

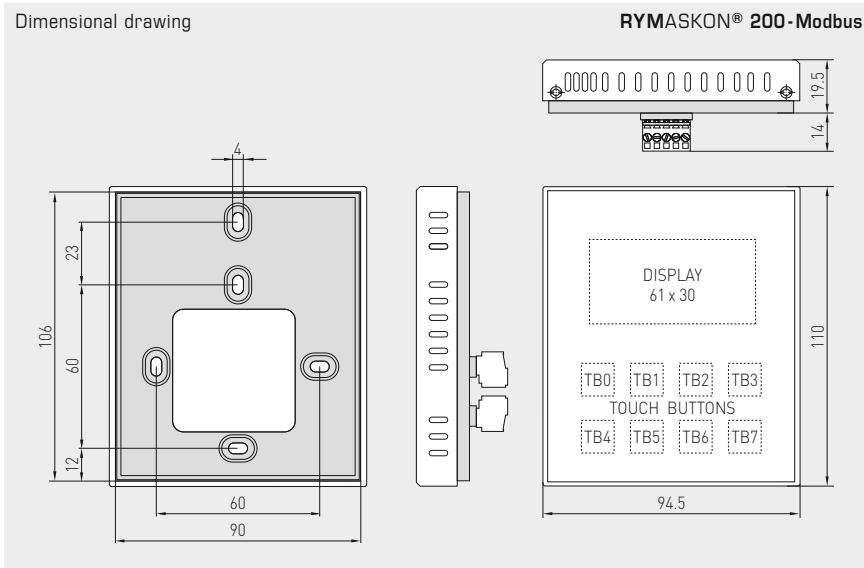

**RYMASKON® 200-Modbus**  
Type 231



**RYMASKON® 200-Modbus** Room control unit for room automation

Type / WG02	Communication	Buttons	Control	Colour	Display	Item No.	Price	
<b>RYMASKON® 210-Modbus</b>								
RYMASKON 211	RS485, NFC, NEC	4	T   -   -   -   R   M	black	■	1901-5111-3011-001	<b>319,89 €</b>	
RYMASKON 212	RS485, NFC, NEC	4	T   -   -   -   R   M	white	■	1901-5111-3012-001	<b>331,17 €</b>	
<b>RYMASKON® 220-Modbus</b>								
RYMASKON 221	RS485, NFC, NEC	6	T   V   -   -   R   M	black	■	1901-5111-3011-002	<b>319,89 €</b>	
RYMASKON 222	RS485, NFC, NEC	6	T   V   -   -   R   M	white	■	1901-5111-3012-002	<b>331,17 €</b>	
<b>RYMASKON® 230-Modbus</b>								
RYMASKON 231	RS485, NFC, NEC	8	T   V   -   L   R   M	black	■	1901-5111-3011-003	<b>319,89 €</b>	
RYMASKON 232	RS485, NFC, NEC	8	T   V   -   L   R   M	white	■	1901-5111-3012-003	<b>331,17 €</b>	
<b>RYMASKON® 240-Modbus</b>								
RYMASKON 241	RS485, NFC, NEC	8	T   -   S   L   R   M	black	■	1901-5111-3011-004	<b>319,89 €</b>	
RYMASKON 242	RS485, NFC, NEC	8	T   -   S   L   R   M	white	■	1901-5111-3012-004	<b>331,17 €</b>	
<b>RYMASKON® 250-Modbus</b>								
RYMASKON 251	RS485, NFC, NEC	8	T   V   S   -   R   M	black	■	1901-5111-3011-005	<b>319,89 €</b>	
RYMASKON 252	RS485, NFC, NEC	8	T   V   S   -   R   M	white	■	1901-5111-3012-005	<b>331,17 €</b>	
<b>RYMASKON® 260-Modbus</b>								
RYMASKON 261	RS485, NFC, NEC	8	T   V   S   L   -   M	black	■	1901-5111-3011-006	<b>319,89 €</b>	
RYMASKON 262	RS485, NFC, NEC	8	T   V   S   L   -   M	white	■	1901-5111-3012-006	<b>331,17 €</b>	
<b>Control:</b>	<b>T</b> = Temperature	<b>V</b> = Ventilation	<b>R</b> = Room occupancy					
	<b>S</b> = Sun protection	<b>L</b> = Light	<b>M</b> = Menu					
<b>ACCESSORIES</b>								
<b>KA2-Modbus</b>	<b>Communication adapter</b> (USB/RS485) for system connection					1906-1200-0000-100	<b>203,80 €</b>	
<b>LA-Modbus</b>	<b>Line termination device</b> (with terminating resistor) as an active bus termination					1906-1300-0000-100	<b>76,01 €</b>	

Roomoperating humidity and temperature sensor ( $\pm 2.0\%$ ), on-wall,  
for temperature, relative / absolute humidity, dew point, mixture ratio, enthalpy,  
calibratable, with Modbus connection

The calibratable room sensor **HYGRASGARD® RFTF-Modbus** with Modbus connection, with/without optional display in an elegant housing (BalduR2) measures the relative humidity and temperature of the room air. These measurands are used to internally calculate various parameters. The Modbus can be used to retrieve the following parameters: relative humidity [% r. H.], absolute humidity [g/m<sup>3</sup>], mixture ratio [g/kg], dew point temperature [°C], enthalpy [kJ/kg] (ignoring atmospheric air pressure) and room temperature [°C].

As operating element you can choose between a potentiometer, a 5-pole rotary switch or a presence button. For the temperature/relative humidity / absolute humidity / dew point / mixture ratio / enthalpy or setpoint output devices with LCD display are optionally available for displaying readings. Operating status can be displayed via a maximum of 5 multi-coloured LEDs. These displays (LCDs), as well as the retrieval of measurement and control values, are controlled via the Modbus interface.

**RFTF-Modbus-PTD5 5L**  
with potentiometer, push-buttons,  
rotary switches and LED display



**TECHNICAL DATA**

Power supply:	24 V AC ( $\pm 20\%$ ) and 15...36 V DC
Power consumption:	< 1 VA / 24 V DC, < 2.2 VA / 24 V AC
Sensor:	<b>Digital humidity sensor with integrated temperature sensor,</b> low hysteresis, high long-term stability
Data points:	Temperature, relative humidity, absolute humidity, dew point, mixture ratio, enthalpy and setpoint potentiometer, rotary switch and presence button
Measuring range:	0...100% r.H. (humidity) 0...+50 °C (temperature)
Deviation, humidity:	typically $\pm 2.0\%$ (20...80% r. H.) at +25 °C, otherwise $\pm 3.0\%$
Temperature deviation:	typically $\pm 0.2$ K at +25 °C
Zero point offset:	$\pm 10\%$ r.H. (humidity) $\pm 10$ °C (temperature) adjustable using potentiometer
Ambient temperature:	Storage -35...+85 °C; Operation 0...+50 °C
Medium:	clean air and other <b>non-aggressive</b> , non-combustible gases
Bus protocol:	Modbus (RTU mode), address range 0...247 selectable, LEDs colour-programmable
Signal filtering:	4 s / 32 s
Housing:	plastic, material ABS, colour pure white (similar to RAL 9010)
Dimensions:	98 x 98 x 33 mm (BalduR2)
Installation:	wall mounting or on in-wall flush box, $\varnothing$ 55 mm, base with 4 holes, for attachment to vertically or horizontally installed in-wall flush boxes for rear cable entry, with predetermined breaking point for cable entry from top/bottom in case of plain on-wall installation
Long-term stability:	$\pm 1\%$ / year
Permissible air humidity:	< 95% r. H., non-precipitating air
Protection class:	III (according to EN 60 730)
Protection type:	IP30 (according to EN 60 529)
Standards:	CE conformity according to EMC Directive 2014/30/EU, according to EN 61 326
Features:	<b>Display with illumination</b> , two-line, programmable, cutout approx. 36 x 15 mm (W x H), to display actual humidity and temperature or a selectable parameter or an individually programmable display value
<b>ACCESSORIES</b>	see table

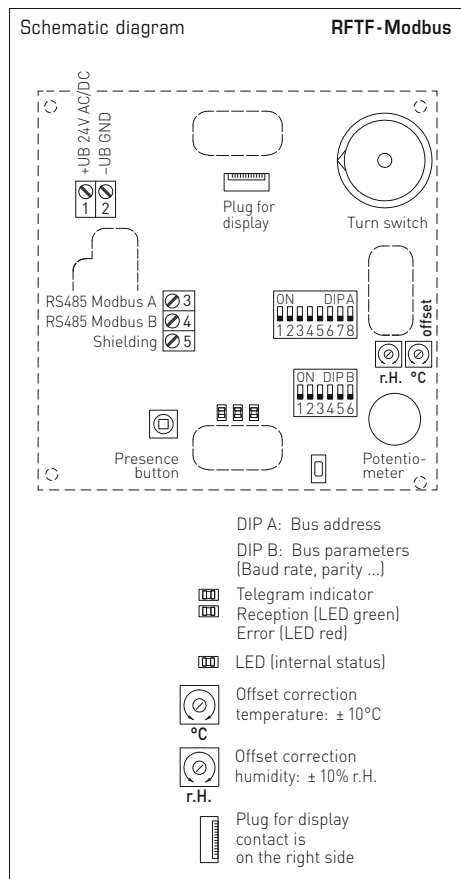
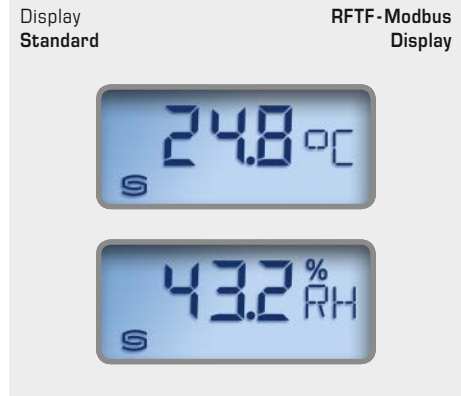





S+S REGELTECHNIK

Roomoperating humidity and temperature sensor ( $\pm 2.0\%$ ), on-wall,  
for temperature, relative / absolute humidity, dew point, mixture ratio, enthalpy,  
calibratable, with Modbus connection

Dimensional drawing

Housing Baldur 2

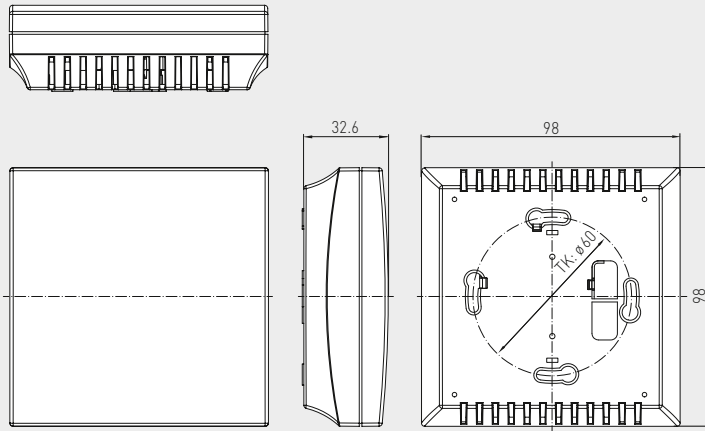

RFTF-Modbus-PT 5L  
with display, potentiometer,  
push-buttons and LED display



Display  
alternative output variables

RFTF-Modbus  
Display



By default, the display alternates between the **actual temperature** and the **actual humidity** (relative humidity). For improved legibility, backlighting is provided.

The Modbus interface allows the display to be **individually** configured both in the 7-segment area and in the dot-matrix area.

The **Modbus configuration** can be used to program an alternative output variable instead of the standard display.

In this case, the first line displays the value and index while the second line displays the corresponding unit.

The index identifies the display type:

- Index 1 = temperature in °C
- Index 2 = setpoint potentiometer in %
- Index 3 = dew point in °C
- Index 4 = relative humidity in % r.H.
- Index 5 = absolute humidity in g/m<sup>3</sup>
- Index 6 = mixture ratio in g/kg
- Index 7 = enthalpy in kJ/kg

HYGRASGARD® RFTF-Modbus		Roomoperating humidity and temperature sensor				
Type / WG01	Measuring Range / Readout Humidity (switchable)	Temperature	Output	Display	Item No.	Price
<b>RFTF-Modbus-xx</b>						
RFTF-Modbus P	0...100% r. H. (default) 0...80 g/kg (MR) 0...80 g/m <sup>3</sup> (A.H.) 0...85 kJ/kg (ENT.) -20...+80 °C (DP)	0...+50 °C	Modbus		1201-42B6-6001-005	190,95 €
RFTF-Modbus P LCD	(5x as above)	(1x as above)	Modbus	■	1201-42B6-7001-005	227,32 €
RFTF-Modbus P 5L	(5x as above)	(1x as above)	Modbus		1201-42B6-6119-005	246,23 €
RFTF-Modbus P 5L LCD	(5x as above)	(1x as above)	Modbus	■	1201-42B6-7119-005	282,60 €
RFTF-Modbus P D5	(5x as above)	(1x as above)	Modbus		1201-42B6-6012-841	219,75 €
RFTF-Modbus P D5 5L	(5x as above)	(1x as above)	Modbus		1201-42B6-6120-841	277,33 €
RFTF-Modbus P T D5 5L	(5x as above)	(1x as above)	Modbus		1201-42B6-6121-841	291,16 €
RFTF-Modbus P T	(5x as above)	(1x as above)	Modbus		1201-42B6-6047-005	202,47 €
RFTF-Modbus P T LCD	(5x as above)	(1x as above)	Modbus	■	1201-42B6-7047-005	238,84 €
RFTF-Modbus P T 5L	(5x as above)	(1x as above)	Modbus		1201-42B6-6051-005	260,05 €
RFTF-Modbus P T 5L LCD	(5x as above)	(1x as above)	Modbus	■	1201-42B6-7051-005	296,42 €
<b>Equipment:</b>	P = Potentiometer (setpoint setter) T = Presence push-buttons		D5 = Rotary switch, 5-step 5L = LED display, multi-colour (5x)			
<b>ACCESSORIES</b>						
KA2-Modbus	Communication adapter (USB/RS485)				1906-1200-0000-100	203,80 €

**Room operating temperature sensor (± 2.0 %), on-wall,  
for temperature, relative humidity, dew point,  
calibratable, with Modbus connection**

Calibratable room temperature measuring transducer **THERMASGARD® RTM1-Modbus** with Modbus connection, with/without optional display for displaying the actual temperature, in an elegant housing made of plastic, with snap-on lid, base with 4-hole attachment, for installation on vertically or horizontally installed in-wall flush boxes, with predetermined breaking point for on-wall cable entry.

The calibrateable room operating sensor measures the temperature of non-aggressive gases, particularly air. In this case, a setpoint potentiometer is available as an operating element. For temperature/humidity/dew point or setpoint readings, optional devices with LCD displays for displaying readings are available. The displays (LCD), as well as the retrieval of measurement and control values, are triggered via the Modbus interface.

**RTM1 - Modbus**  
Standard



**TECHNICAL DATA**

Voltage supply:	24 V AC (± 20 %) and 15...36 V DC
Power consumption:	< 1.0 VA / 24 V DC < 2.2 VA / 24 V AC
Sensor:	<b>digital humidity sensor with integrated temperature sensor,</b> low hysteresis, high long-term stability
Data points:	temperature, relative humidity, dew point, setpoint potentiometer
Measuring range:	0...+50 °C
Deviation, humidity:	typically <b>± 2.0 %</b> (20...80 % r. H.) at +25 °C, otherwise ± 3.0 %
Temperature deviation:	typically ± 0.2 K at +25 °C
Zero point offset:	± 10 °C, adjustable by potentiometer
Ambient temperature:	storage -35...+85 °C; operation 0...+50 °C
Medium:	clean air and non-aggressive, non-combustible gases
Bus protocol:	Modbus (RTU mode), address range 0... <b>247</b> selectable
Signal filtering:	4 s / 32 s
Process connection:	by screws
Housing:	plastic, material ABS, colour pure white (similar to RAL 9010)
Dimensions:	85 x 85 x 27 mm (Baldur 1)
Installation:	wall mounting or on in-wall flush box, Ø 55 mm, base with 4 holes, for attachment to vertically or horizontally installed in-wall flush boxes for rear cable entry, with predetermined breaking point for cable entry from top/bottom in case of plain on-wall installation
Permissible air humidity:	< 95 % r. H., non-precipitating air
Protection class:	III (according to EN 60 730)
Protection type:	<b>IP 30</b> (according to EN 60 529)
Standards:	CE conformity, electromagnetic compatibility according to EN 61326, according to EMC Directive 2014/30/EU
Optional:	two-line <b>display with illumination</b> , programmable, cutout approx. 36 x 15 mm (W x H), for displaying the actual temperature or an individually programmable display value (The Modbus interface allows the display to be individually configured in the 7-segment area and in the dot-matrix area.)
<b>ACCESSORIES</b>	see table

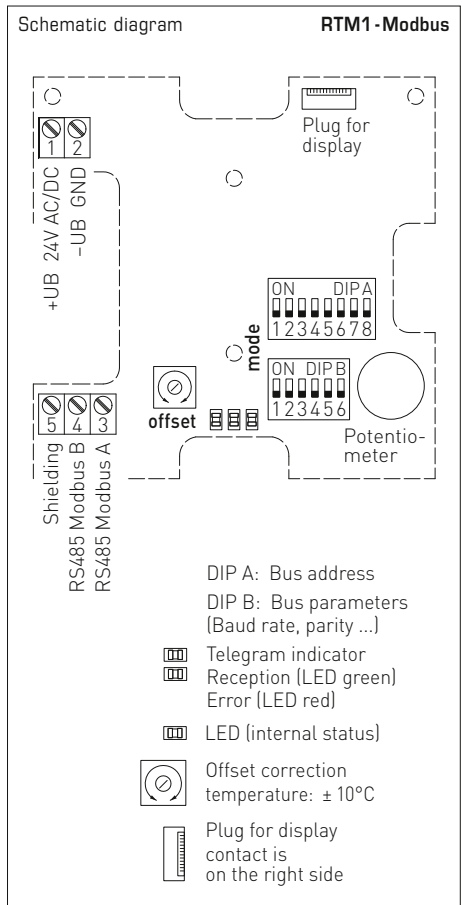



S+S REGELTECHNIK

Room operating temperature sensor ( $\pm 2.0\%$ ), on-wall,  
for temperature, relative humidity, dew point,  
calibratable, with Modbus connection

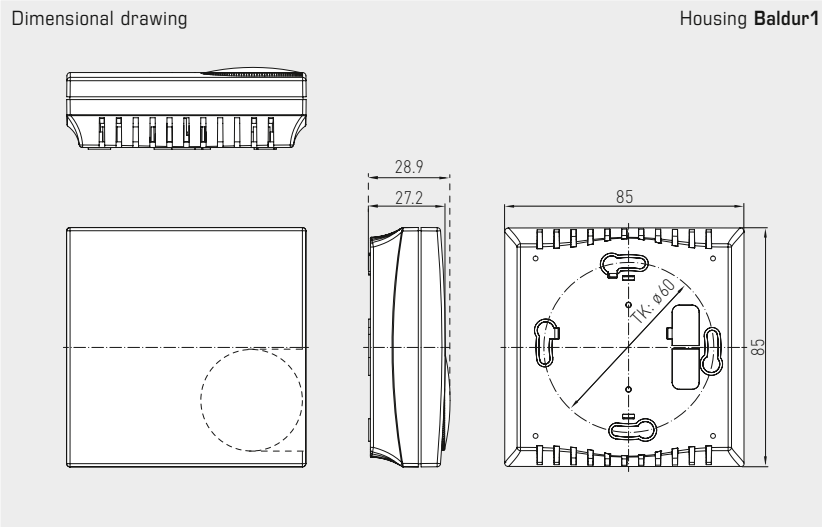

RTM1-Modbus  
with display



RTM1-Modbus-P  
with display and  
potentiometer



RTM1-Modbus-P  
with potentiometer



RTM1-Modbus  
with display



RTM1-Modbus  
without display

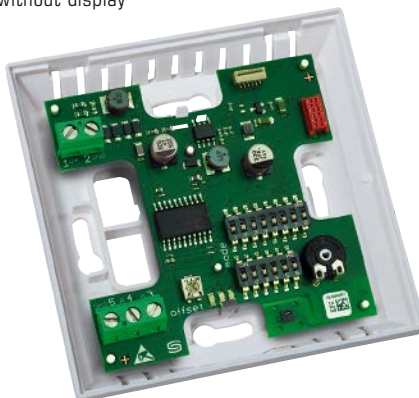

THERMASGARD® RTM 1 - Modbus Room operating temperature sensor

Type / WG01	Sensor	Output	Equipment	Display	Item No.	Price
<b>RTM 1 - Modbus</b>					<b>IP30</b>	
RTM1-Modbus	digital	Modbus	–		1101-42A6-0000-000	109,73 €
RTM1-Modbus LCD	digital	Modbus	–	■	1101-42A6-2000-000	162,48 €
<b>RTM 1 - P - Modbus</b>					<b>IP30</b>	
RTM1-Modbus P	digital	Modbus	potentiometer		1101-42A6-0001-005	144,28 €
RTM1-Modbus P LCD	digital	Modbus	potentiometer	■	1101-42A6-2001-005	259,83 €
<b>ACCESSORIES</b>						
KA2-Modbus	Communication adapter (USB/RS485) for system connection				1906-1200-0000-100	203,80 €
LA-Modbus	Line termination device (with terminating resistor) as an active bus termination				1906-1300-0000-100	76,01 €

**Outside temperature / wet room  
temperature measuring transducers, calibratable,  
with Modbus connection**

Calibratable outside temperature measurement transducer **THERMASGARD®  
ATM 2 - Modbus - T3** with Modbus connection, in an impact-resistant plastic housing  
with quick-locking screws, optionally with /without display.

The on-wall sensor is used to detect the temperature in gaseous media. It is used outside  
or in wet rooms, in cold storage buildings and greenhouses, in the industrial sector and in  
agriculture. Installation on outside walls is preferably performed on the north side or in a  
protected place. In case of direct solar irradiation, we recommend using our sun and  
ball-impact protection hood **WS01** or **WS04** (accessories).

**Innovative Modbus sensor** with galvanically separated RS485 Modbus interface, selectable  
bus termination resistance, DIP switch for setting the bus parameters and bus address in  
current-free state, LEDs for telegram status display, two separate push-in terminals and  
large three-line display (illuminated,  
with customised programming in the 7-segment range and dot-matrix range). Uses **internal  
diagnostics** to detect sensor breakage or sensor short circuit as errors. The error messages  
can be retrieved via Modbus and are shown on the display. The sensor is factory-calibrated;  
an environmental precision adjustment by an expert is possible.

**ATM 2 - Modbus - T3**



Device variant  
with **M12 connector**  
(optional on request)



**TECHNICAL DATA**

Voltage supply:	24 V AC (±20%) and 15...36 V DC
Power consumption:	< 1.2 W / 24 V DC; < 1.8 VA / 24 V AC
Sensor:	Pt1000, DIN EN 60751, class B
Measuring range:	-50...+150 °C
Temperature deviation:	typically ± 0.2 K at +25 °C
Zero point offset:	± 10 °C
Ambient temperature:	Measuring transducer -30...+70 °C
Medium:	clean air and non-aggressive, non-combustible gases
Bus protocol:	Modbus (RTU mode), address range 0... <b>247</b> selectable
Signal filtering:	0.3 s / 1 s / 10 s
Process connection:	by screws
Housing:	plastic, UV-resistant, material polyamide, 30% glass-globe reinforced, with quick-locking screws (slotted / Phillips head combination), colour traffic white (similar to RAL 9016), housing cover for display is transparent!
Housing dimensions:	108 x 78.5 x 43.3 mm (Tyr 3 without display) 108 x 78.5 x 45.8 mm (Tyr 3 with display)
Cable connection:	<b>cable gland</b> , plastic (2x M20 x 1.5; with strain relief, exchangeable, inner diameter 8 - 13 mm) or <b>M12 connector</b> according to DIN EN 61076-2-101 (optional on request)
Electrical connection:	0.2 - 1.5 mm², using push-in terminals
Permissible air humidity:	< 95% r. H., non-precipitating air
Protection class:	III (according to EN 60 730)
Protection type:	<b>IP65</b> (according to EN 60 529)
Standards:	CE conformity, electromagnetic compatibility according to EN 61326, according to EMC Directive 2014 / 30 / EU
Equipment:	<b>Display with illumination</b> , three-line, programmable, cutout approx. 51 x 29 mm (W x H), for displaying the actual temperature or an individually programmable display value
Internal diagnostics:	<b>Error 1</b> at sensor breakage <b>Error 2</b> at sensor short circuit
<b>ACCESSORIES</b>	see table

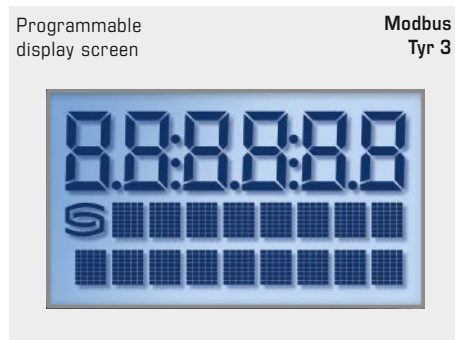
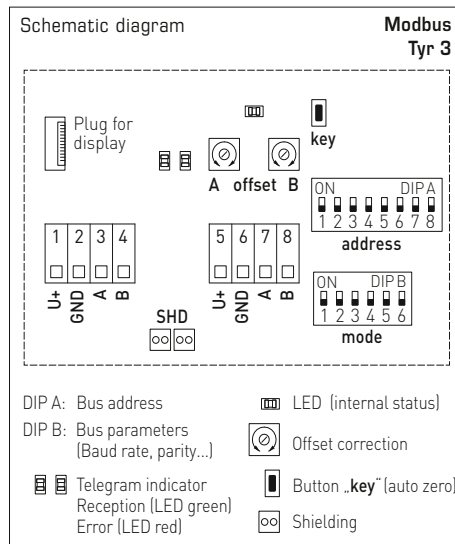





S+S REGELTECHNIK

Outside temperature / wet room temperature measuring transducers, calibratable, with Modbus connection

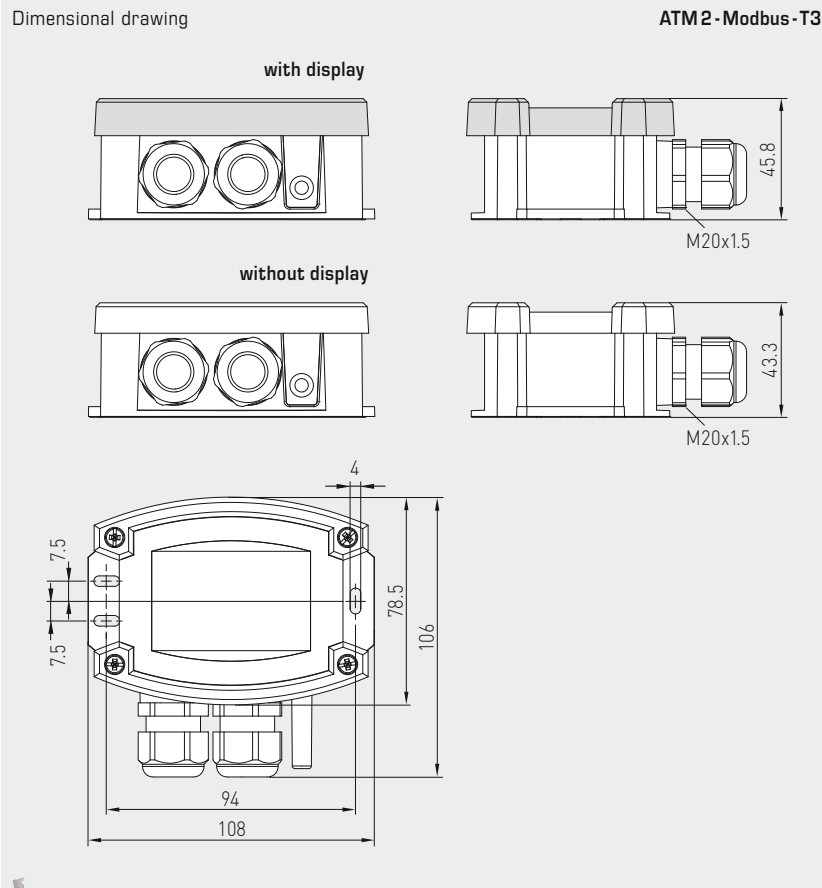

ATM 2 - Modbus - T3 with display



THERMASGARD® ATM 2 - Modbus - T3 Outside temperature / wet room temperature measuring transducers

Type / WG01	Sensor	Output	Display	Item No.	Price
<b>ATM 2 - Modbus - T3</b>					
ATM2-Modbus-T3	Pt1000	Modbus		1101-12C6-0000-000	122,34 €
ATM2-Modbus-T3 LCD	Pt1000	Modbus	■	1101-12C6-4000-000	173,97 €
Optional:	Cable connection with <b>M12 connector</b> according to DIN EN 61076-2-101			on request	

ACCESSORIES

<b>KA2-Modbus</b>	<b>Communication adapter</b> (with USB and RS485 interface) for system connection (incl. quick-start software)			1906-1200-0000-100	203,80 €
<b>LA-Modbus</b>	<b>Line termination device</b> (with terminating resistor) as an active bus termination of RS485 networks			1906-1300-0000-100	76,01 €
<b>WS-01</b>	<b>Sun and ball-impact protection hood</b> , 184 x 180 x 80 mm, stainless steel <b>V2A</b> (1.4301)			7100-0040-2000-000	30,26 €
<b>WS-04</b>	<b>Weather and sun protection hood</b> , 130 x 180 x 135 mm, stainless steel <b>V2A</b> (1.4301)			7100-0040-7000-000	35,70 €

For further information, see last chapter Accessories!

**Immersion / screw-in / duct temperature measuring transducer, calibratable, with Modbus connection**

**Patented quality product (Immersion sensor patent no. DE 10 2012 017 500.0)**

Calibratable temperature measuring transducer with sensor tube **THERMASGARD® TM 65 - Modbus - T3** with Modbus connection, in an impact-resistant plastic housing with quick-locking screws, optionally with /without display, stainless steel-protective tube (50–400 mm).

The duct sensor is used to detect the temperature in liquid or gaseous media. Use the stainless steel immersion sleeves for aggressive media. It is used in heating engineering, ventilation and air conditioning ducts, pipes, storage systems, compact district heating stations, warm and cold water systems, oil and lubrication cycle systems, machine and systems engineering and the entire industry sector.

**Innovative Modbus sensor** with galvanically separated RS485 Modbus interface, selectable bus termination resistance, DIP switch for setting the bus parameters and bus address in current-free state, LEDs for telegram status display, two separate push-in terminals and large three-line display (illuminated, with customised programming in the 7-segment range and dot-matrix range). Uses **internal diagnostics** to detect sensor breakage or sensor short circuit as errors. The error messages can be retrieved via Modbus and are shown on the display. The sensor is factory-calibrated; an environmental precision adjustment by an expert is possible.

TM 65 - Modbus - T3



Device version with **M12 connector** (optional on request)



**TECHNICAL DATA**

Voltage supply:	24 V AC (± 20%) and 15...36 V DC
Power consumption:	< 1.2 W / 24 V DC; < 1.8 VA / 24 V AC
Sensor:	Pt1000, DIN EN 60751, class B <b>(Perfect Sensor Protection)</b>
Measuring range:	-50...+150 °C
Temperature deviation:	typically ± 0.2 K at +25 °C
Zero point offset:	± 10 °C
Ambient temperature:	Measuring transducer -30...+70 °C
Medium:	depending on selected immersion sleeve
Bus protocol:	Modbus (RTU mode), address range 0... <b>247</b> selectable
Signal filtering:	0.3 s / 1 s / 10 s
Protective tube:	stainless steel, <b>V4A</b> (1.4571), Ø = 6 mm, inserted length (EL) = 50 - 400 mm (see table)
Housing:	plastic, UV-resistant, material polyamide, 30 % glass-globe reinforced, with quick-locking screws (slotted / Phillips head combination), colour traffic white (similar to RAL 9016), housing cover for display is transparent!
Housing dimensions:	108 x 78.5 x 43.3 mm (Tyr 3 without display) 108 x 78.5 x 45.8 mm (Tyr 3 with display)
Cable connection:	<b>cable gland</b> , plastic (2x M 20 x 1.5; with strain relief, exchangeable, inner diameter 8 - 13 mm) <b>or</b> <b>M12 connector</b> according to DIN EN 61076-2-101 (optional on request)
Electrical connection:	0.2 - 1.5 mm², using push-in terminals
Permissible air humidity:	< 95% r. H., non-precipitating air
Protection class:	III (according to EN 60 730)
Protection type:	<b>IP 65</b> (according to EN 60 529)
Standards:	CE conformity, electromagnetic compatibility according to EN 61326, according to EMC Directive 2014 / 30 / EU
Equipment:	<b>Display with illumination</b> , three-line, programmable, cutout approx. 51 x 29 mm (W x H), for displaying the actual temperature or an individually programmable display value
Internal diagnostics:	<b>Error 1</b> at sensor breakage <b>Error 2</b> at sensor short circuit
<b>ACCESSORIES</b>	see table

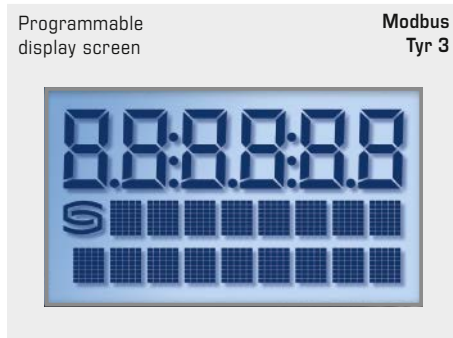
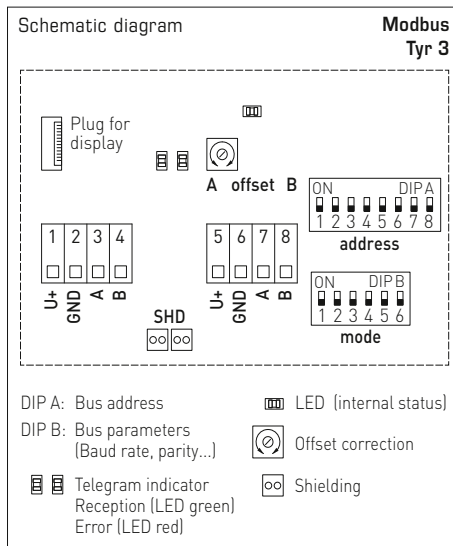

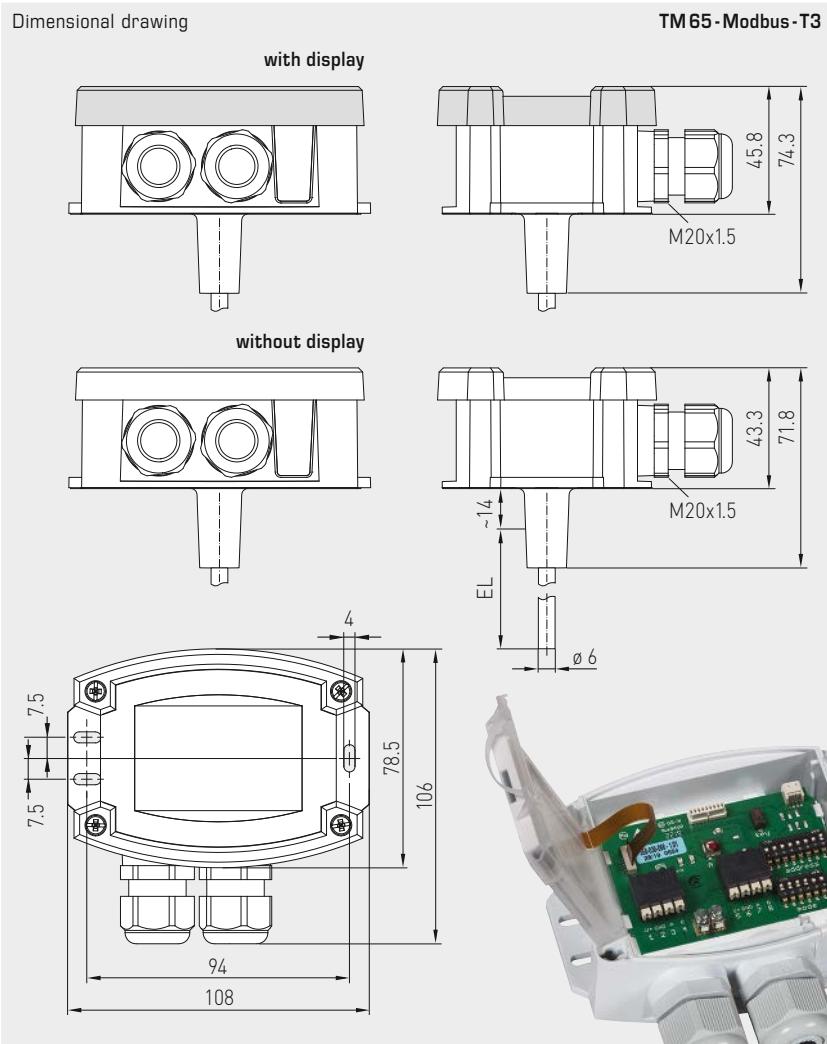

High-performance encapsulation against vibration, mechanical stress and humidity

**PS-PROTECTION**  
PERFECT SENSOR PROTECTION



THERMASGARD® TM 65 - Modbus - T3 Temperature sensor (basic device)

Type / WG01	Output	Inserted Length [EL]	Display	Item No.	Price
<b>TM65-Modbus-T3</b>					
TM65-Modbus-T3 50mm	Modbus	50 mm		1101-7236-0010-000	122,01 €
TM65-Modbus-T3 50mm LCD	Modbus	50 mm	■	1101-7236-4010-000	173,62 €
TM65-Modbus-T3 100mm	Modbus	100 mm		1101-7236-0020-000	122,28 €
TM65-Modbus-T3 100mm LCD	Modbus	100 mm	■	1101-7236-4020-000	173,89 €
TM65-Modbus-T3 150mm	Modbus	150 mm		1101-7236-0030-000	122,49 €
TM65-Modbus-T3 150mm LCD	Modbus	150 mm	■	1101-7236-4030-000	174,14 €
TM65-Modbus-T3 200mm	Modbus	200 mm		1101-7236-0040-000	122,71 €
TM65-Modbus-T3 200mm LCD	Modbus	200 mm	■	1101-7236-4040-000	174,33 €
TM65-Modbus-T3 250mm	Modbus	250 mm		1101-7236-0050-000	123,01 €
TM65-Modbus-T3 250mm LCD	Modbus	250 mm	■	1101-7236-4050-000	174,65 €
TM65-Modbus-T3 300mm	Modbus	300 mm		1101-7236-0060-000	123,77 €
TM65-Modbus-T3 300mm LCD	Modbus	300 mm	■	1101-7236-4060-000	175,38 €
TM65-Modbus-T3 350mm	Modbus	350 mm		1101-7236-0070-000	124,76 €
TM65-Modbus-T3 350mm LCD	Modbus	350 mm	■	1101-7236-4070-000	176,41 €
TM65-Modbus-T3 400mm	Modbus	400 mm		1101-7236-0080-000	125,77 €
TM65-Modbus-T3 400mm LCD	Modbus	400 mm	■	1101-7236-4080-000	177,43 €
Optional:	Cable connection with <b>M12 connector</b> according to DIN EN 61076-2-101			on request	
<b>ACCESSORIES</b>					
<b>KA2-Modbus</b>	<b>Communication adapter</b> (USB/RS485) for system connection			1906-1200-0000-100	203,80 €
<b>LA-Modbus</b>	<b>Line termination device</b> (with terminating resistor) as an active bus termination			1906-1300-0000-100	76,01 €

Immersion / screw-in / duct temperature measuring transducer, calibratable, with Modbus connection

One basic device in four variants ...



**PATENTED**

**TM 65 - Modbus - T3 + TH08 - ms / xx**

Immersion / screw-in temperature sensor with immersion sleeve, brass, nickel-plated

**TM 65 - Modbus - T3 + TH08 - VA / xx**

Immersion / screw-in temperature sensor with immersion sleeve, stainless steel, V4A

**TM 65 - Modbus - T3 + TH08 - VA / xx / 90**

Immersion / screw-in temperature sensor with immersion sleeve with neck tube, stainless steel, V4A

**TM 65 - Modbus - T3 + MF - 15 - K**

Duct temperature sensor with mounting flange, plastic

Dimensional drawing TH08 - ms / xx

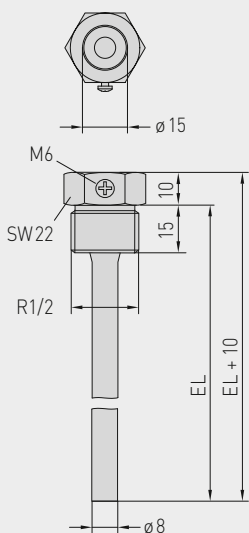

Dimensional drawing TH08 - VA / xx

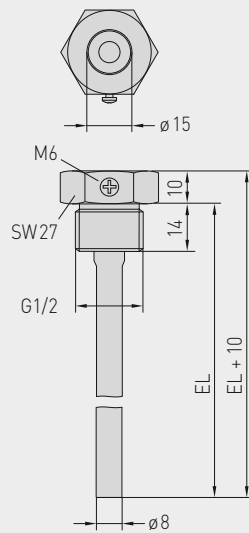

Dimensional drawing TH08 - VA / xx / 90

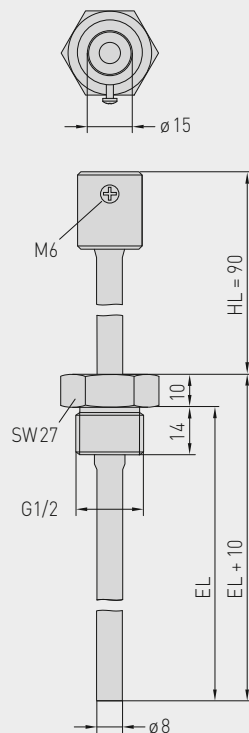

Dimensional drawing MF - 15 - K

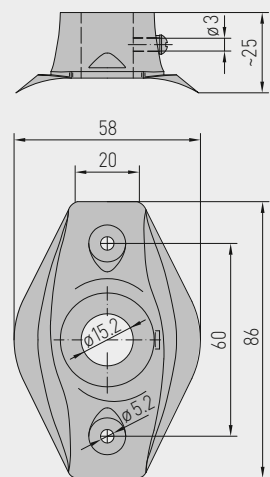





... through combination with accessories:



**TH08-ms/xx**  
Immersion sleeve, brass, nickel-plated, thread-sealing, conical, according to DIN 10226



**TH08-VA/xx**  
Immersion sleeve, stainless steel, V4A, flat-sealing, cylindrical, according to DIN 228



**TH08-VA/xx/90**  
Immersion sleeve with neck tube, stainless steel, V4A, flat-sealing, cylindrical, according to DIN 228



**MF-15-K**  
Mounting flange, plastic

**THERMASGARD® TH08** Immersion sleeve Ø 8 mm (Accessories)

Type / WG01B	p <sub>max</sub> (static)	T <sub>max</sub>	Inserted Length (EL)	Item No.	Price
<b>TH08-ms/xx</b>	<b>Brass nickel-plated</b>			without neck tube	
TH08-MS 50MM	10 bar	+150 °C	<b>50 mm</b>	7100-0011-0010-132	<b>8,87 €</b>
TH08-MS 100MM	10 bar	+150 °C	<b>100 mm</b>	7100-0011-0020-132	<b>10,10 €</b>
TH08-MS 150MM	10 bar	+150 °C	<b>150 mm</b>	7100-0011-0030-132	<b>10,67 €</b>
TH08-MS 200MM	10 bar	+150 °C	<b>200 mm</b>	7100-0011-0040-132	<b>11,01 €</b>
TH08-MS 250MM	10 bar	+150 °C	<b>250 mm</b>	7100-0011-0050-132	<b>12,75 €</b>
TH08-MS 300MM	10 bar	+150 °C	<b>300 mm</b>	7100-0011-0060-132	<b>13,10 €</b>
TH08-MS 350MM	10 bar	+150 °C	<b>350 mm</b>	7100-0011-0070-132	<b>13,21 €</b>
TH08-MS 400MM	10 bar	+150 °C	<b>400 mm</b>	7100-0011-0080-132	<b>13,33 €</b>
<b>TH08-VA/xx</b>	<b>Stainless steel V4A (1.4571)</b>			without neck tube	
TH08-VA 50MM	40 bar	+600 °C	<b>50 mm</b>	7100-0012-0010-132	<b>19,31 €</b>
TH08-VA 100MM	40 bar	+600 °C	<b>100 mm</b>	7100-0012-0020-132	<b>21,34 €</b>
TH08-VA 150MM	40 bar	+600 °C	<b>150 mm</b>	7100-0012-0030-132	<b>22,93 €</b>
TH08-VA 200MM	40 bar	+600 °C	<b>200 mm</b>	7100-0012-0040-132	<b>24,17 €</b>
TH08-VA 250MM	40 bar	+600 °C	<b>250 mm</b>	7100-0012-0050-132	<b>30,05 €</b>
TH08-VA 300MM	40 bar	+600 °C	<b>300 mm</b>	7100-0012-0060-132	<b>31,40 €</b>
TH08-VA 350MM	40 bar	+600 °C	<b>350 mm</b>	7100-0012-0070-132	<b>31,61 €</b>
TH08-VA 400MM	40 bar	+600 °C	<b>400 mm</b>	7100-0012-0080-132	<b>32,17 €</b>
<b>TH08-VA/xx/90</b>	<b>Stainless steel V4A (1.4571)</b>			with neck tube (90 mm)	
TH08-VA 50/90MM	40 bar	+600 °C	<b>50 mm</b>	7100-0012-0012-132	<b>27,66 €</b>
TH08-VA 100/90MM	40 bar	+600 °C	<b>100 mm</b>	7100-0012-0022-132	<b>28,90 €</b>
TH08-VA 150/90MM	40 bar	+600 °C	<b>150 mm</b>	7100-0012-0032-132	<b>30,32 €</b>
TH08-VA 200/90MM	40 bar	+600 °C	<b>200 mm</b>	7100-0012-0042-132	<b>31,61 €</b>
TH08-VA 250/90MM	40 bar	+600 °C	<b>250 mm</b>	7100-0012-0052-132	<b>33,13 €</b>
TH08-VA 300/90MM	40 bar	+600 °C	<b>300 mm</b>	7100-0012-0062-132	<b>35,91 €</b>

Note: inner diameter of socket 15.0 mm  
For further information see last chapter!

**Mounting flange (Accessories)**

Type / WG01B	Item No.	Price
<b>MF</b>		
<b>MF-15-K</b>	7100-0032-0000-000	<b>5,83 €</b>
<b>Mounting flange, plastic, 56.8x84.3mm, Ø 15.2mm tube gland, T<sub>max</sub> +100°C</b>		

Note: For information see last chapter!

Mean value temperature measuring transducers,  
incl. mounting flange, calibratable,  
with Modbus connection

Calibratable mean value temperature measuring transducer **THERMASGARD® MWTM-Modbus-T3** with Modbus connection, in an impact-resistant plastic housing with quick-locking screws, optionally with/without display, with flexible sensor rod (0.4...20m, fully active) in a robust protective plastic-coated copper tube, incl. mounting flange.

The rod sensor is used to detect the mean temperature (mean value) in gaseous media. It is used in ventilation and air conditioning ducts over the entire cross-section or on a defined length (laid along a meandering route, it uniformly detects the surrounding temperature). For proper mounting of the rod, mounting clamps **MK-05-M** (accessories) are available.

**Innovative Modbus sensor** with galvanically separated RS485 Modbus interface, selectable bus termination resistance, DIP switch for setting the bus parameters and bus address in current-free state, LEDs for telegram status display, two separate push-in terminals and large three-line display (illuminated, with customised programming in the 7-segment range and dot-matrix range). Uses **internal diagnostics** to detect sensor breakage or sensor short circuit as errors. The error messages can be retrieved via Modbus and are shown on the display. The sensor is factory-calibrated; an environmental precision adjustment by an expert is possible.

**MWTM-Modbus-T3**  
Rod length  
3m / 6m



Device version with **M12 connector** (optional on request)



**TECHNICAL DATA**

Voltage supply:	24 V AC (±20%) and 15...36 V DC
Power consumption:	< 1.2 W / 24 V DC; < 1.8 VA / 24 V AC
Sensor:	Pt1000, DIN EN 60751, class B
Measuring range:	-50...+150 °C; <b>T<sub>min</sub> -50 °C, T<sub>max</sub> +80 °C</b>
Temperature deviation:	typically ±0.2 K at +25 °C
Zero point offset:	±10 °C
Medium:	clean air and non-aggressive, non-combustible gases
Bus protocol:	Modbus (RTU mode), address range 0... <b>247</b> selectable
Signal filtering:	0.3 s / 1 s / 10 s
<b>Sensors:</b>	active across the entire length (averaging)
Rod material:	<b>protective tube made from copper, plastic-coated</b> , with anti-kink spring and sleeve, stainless steel V4A (1.4571)
Rod dimensions:	Ø = 5.0 mm, nominal length (NL) = 0.4 m / 3 m / 6 m (nominal length optional up to max. 20 m)
Rod laying:	Bending radius: <b>&gt; 35 mm</b> Vibration load: <b>≤ 0.5 g</b> Tensile load: <b>&lt; 480 N</b>
Housing:	plastic, UV-resistant, material polyamide, 30% glass-globe reinforced, with quick-locking screws (slotted / Phillips head combination), colour traffic white (similar to RAL 9016), housing cover for display is transparent!
Housing dimensions:	108 x 78.5 x 43.3 mm (Tyr 3 without display) 108 x 78.5 x 45.8 mm (Tyr 3 with display)
Cable connection:	<b>cable gland</b> , plastic (2x M20 x 1.5; with strain relief, exchangeable, inner diameter 8 - 13 mm) or <b>M12 connector</b> according to DIN EN 61076-2-101 (optional on request)
Electrical connection:	0.2 - 1.5 mm <sup>2</sup> , using push-in terminals
Process connection:	by mounting flange, plastic (galvanised steel optional, see accessories) and mounting clamps <b>MK-05-M</b>
Ambient temperature:	Measuring transducer -30...+70 °C
Permissible air humidity:	<95% r. H., non-precipitating air
Protection class:	III (according to EN 60 730)
Protection type:	<b>IP 65</b> (according to EN 60 529)
Standards:	CE conformity, electromagnetic compatibility according to EN 61326, according to EMC Directive 2014 / 30 / EU
Equipment:	<b>Display with illumination</b> , three-line, programmable, cutout approx. 51 x 29 mm (W x H), for displaying the actual temperature, error message or an individually programmable display value
Internal diagnostics:	<b>Error 1</b> at sensor breakage <b>Error 2</b> at sensor short circuit
<b>ACCESSORIES</b>	see table

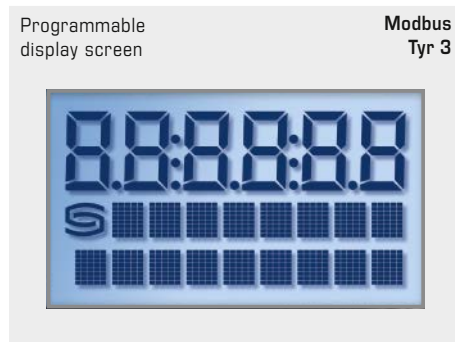
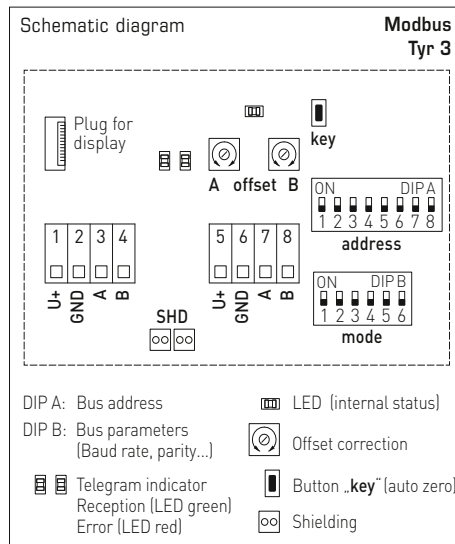



S+S REGELTECHNIK

Mean value temperature measuring transducers,  
incl. mounting flange, calibratable,  
with Modbus connection

Dimensional drawing

MWTM-Modbus-T3

MWTM-Modbus-T3

Rod length  
0,4 m

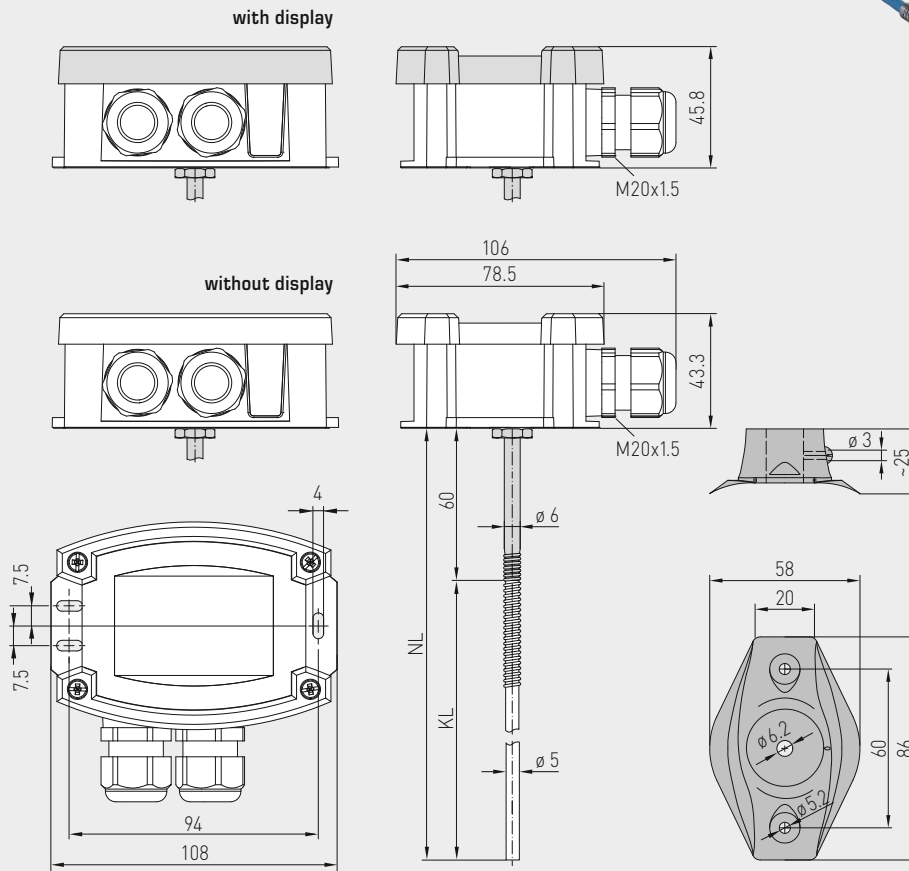

**MF-06-K**  
Mounting flange,  
plastic  
(included in the scope of delivery)



**MK-05-M**

Galvanised steel  
mounting clamps  
(optional)



**MF-06-M**

Mounting flange,  
metal  
(optional)



**KRD-04**

Capillary tube  
gland bracket, plastic  
(optional)

THERMASGARD® MWTM-Modbus-T3 Mean value temperature measuring transducers

Type / WG01	Sensor	Output	Rod length (NL)	Display	Item No.	Price
<b>MWTM-Modbus-T3</b>					<b>IP65</b>	
MWTM-Modbus-T3 0,4m	Pt1000	Modbus	<b>0,4 m</b>		1101-3266-0080-000	<b>191,82 €</b>
MWTM-Modbus-T3 0,4m <b>LCD</b>	Pt1000	Modbus	<b>0,4 m</b>	■	1101-3266-4080-000	<b>243,02 €</b>
MWTM-Modbus-T3 3m	Pt1000	Modbus	<b>3,0 m</b>		1101-3266-0230-000	<b>242,27 €</b>
MWTM-Modbus-T3 3m <b>LCD</b>	Pt1000	Modbus	<b>3,0 m</b>	■	1101-3266-4230-000	<b>293,98 €</b>
MWTM-Modbus-T3 6m	Pt1000	Modbus	<b>6,0 m</b>		1101-3266-0260-000	<b>278,49 €</b>
MWTM-Modbus-T3 6m <b>LCD</b>	Pt1000	Modbus	<b>6,0 m</b>	■	1101-3266-4260-000	<b>330,52 €</b>
Extra charge:	Per meter sensor cable (from 6 m to max. 20 m)				on request	
	Cable connection with <b>M12 connector</b> according to DIN EN 61076-2-101				on request	

**ACCESSORIES**

<b>KA2-Modbus</b>	<b>Communication adapter</b> (USB/RS485) for system connection				1906-1200-0000-100	<b>203,80 €</b>
<b>LA-Modbus</b>	<b>Line termination device</b> (with terminating resistor) as an active bus termination				1906-1300-0000-100	<b>76,01 €</b>
<b>MF-06-K</b>	<b>Mounting flange, plastic</b> (included in the scope of delivery)				7100-0030-1000-000	<b>5,83 €</b>
<b>MF-06-M</b>	<b>Mounting flange, metal, galvanised steel, Ø = 35 mm</b>				7100-0030-5000-100	<b>9,10 €</b>
<b>KRD-04</b>	<b>Capillary tube gland bracket, plastic</b>				7100-0030-7000-000	<b>8,49 €</b>
<b>MK-05-M</b>	<b>Galvanised steel mounting clamps</b> (6 pieces)				7100-0034-0000-000	<b>9,41 €</b>

For further information, see last chapter Accessories!

**Sleeve sensor with temperature measuring transducer, calibratable, with Modbus connection**

Calibratable sleeve temperature measuring transducer **THERMASGARD® HFTM - Modbus - T3** with Modbus connection, in an impact-resistant plastic housing with quick-locking screws, optionally with /without display, cable sensor with a stainless steel sleeve.

The sleeve sensor is used to detect the temperature in liquid and gaseous media. It is used as a duct sensor or, if installed in immersion sleeve **THE** (accessories), as an immersion and screw-in sensor in liquids.

**Innovative Modbus sensor** with galvanically separated RS485 Modbus interface, selectable bus termination resistance, DIP switch for setting the bus parameters and bus address in current-free state, LEDs for telegram status display, two separate push-in terminals and large three-line display (illuminated, with customised programming in the 7-segment range and dot-matrix range). Uses **internal diagnostics** to detect sensor breakage or sensor short circuit as errors. The error messages can be retrieved via Modbus and are shown on the display. The sensor is factory-calibrated; an environmental precision adjustment by an expert is possible.

HFTM - Modbus - T3



Device version with **M12 connector** (optional on request)



**TECHNICAL DATA**

Voltage supply:	24 V AC (±20%) and 15...36V DC
Power consumption:	< 1.2 W / 24 V DC; < 1.8 VA / 24 V AC
Sensor:	Pt1000, DIN EN 60751, class B <b>(Perfect Sensor Protection with IP68)</b>
Measuring range:	-50...+150 °C
Temperature deviation:	typically ±0.2 K at +25 °C
Zero point offset:	±10 °C
Bus protocol:	Modbus (RTU mode), address range 0... <b>247</b> selectable
Signal filtering:	0.3 s / 1 s / 10 s
Medium:	clean air and non-aggressive, non-combustible gases; liquids depending on selected immersion sleeve (accessory)
Sensor protection:	Sensor sleeve made from stainless steel V4A (1.4571), Ø=6 mm, nominal length (NL) = 50 mm (optional 30...400 mm)
Sensor cable:	silicone, SiHF, 2 x 0.25 mm <sup>2</sup> , cable length (KL) = 1.5 m (other lengths and range limits optional, e.g. PTFE leads up to +250 °C or glass fibre with steel wire mesh up to +350 °C)
Housing:	plastic, UV-resistant, material polyamide, 30% glass-globe reinforced, with quick-locking screws (slotted / Phillips head combination), colour traffic white (similar to RAL 9016), housing cover for display is transparent!
Housing dimensions:	108 x 78.5 x 43.3 mm (Tyr 3 without display) 108 x 78.5 x 45.8 mm (Tyr 3 with display)
Cable connection:	<b>cable gland</b> , plastic (2x M20 x 1.5; with strain relief, exchangeable, inner diameter 8 - 13 mm) or <b>M12 connector</b> according to DIN EN 61076-2-101 (optional on request)
Electrical connection:	0.2 - 1.5 mm <sup>2</sup> , using push-in terminals
Ambient temperature:	Measuring transducer -30...+70 °C
Permissible air humidity:	<95% r. H., non-precipitating air
Protection class:	III (according to EN 60 730)
Protection type housing:	<b>IP65</b> (according to EN 60 529)
Protection type sensor:	<b>IP65</b> (according to EN 60 529) <b>sleeve</b> humidity-tight (standard) <b>IP68</b> (according to EN 60 529) <b>sleeve</b> water-tight (optional) <b>IP54</b> (according to EN 60 529) with <b>glass fibre</b> cable (optional)
Standards:	CE conformity, electromagnetic compatibility according to EN 61326, according to EMC Directive 2014 / 30 / EU
Equipment:	<b>Display with illumination</b> , three-line, programmable, cutout approx. 51 x 29 mm (W x H), for displaying the actual temperature, error message or an individually programmable display value
Internal diagnostics:	<b>Error 1</b> at sensor breakage <b>Error 2</b> at sensor short circuit
<b>ACCESSORIES</b>	see table

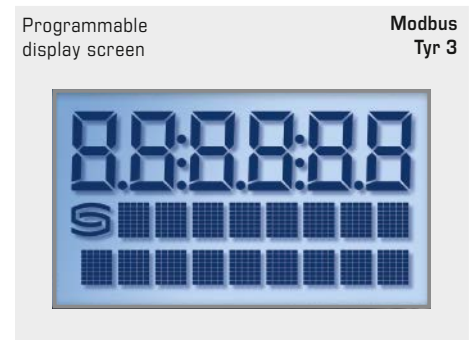
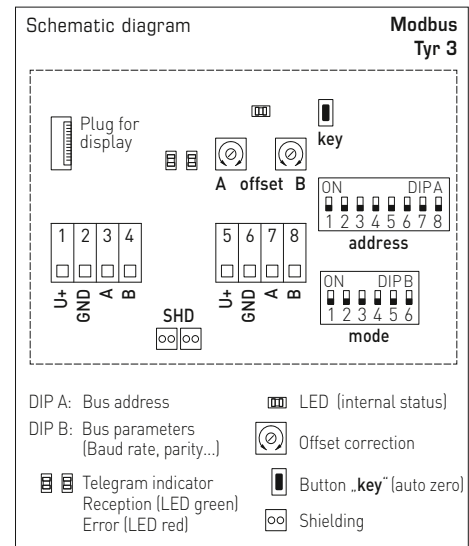



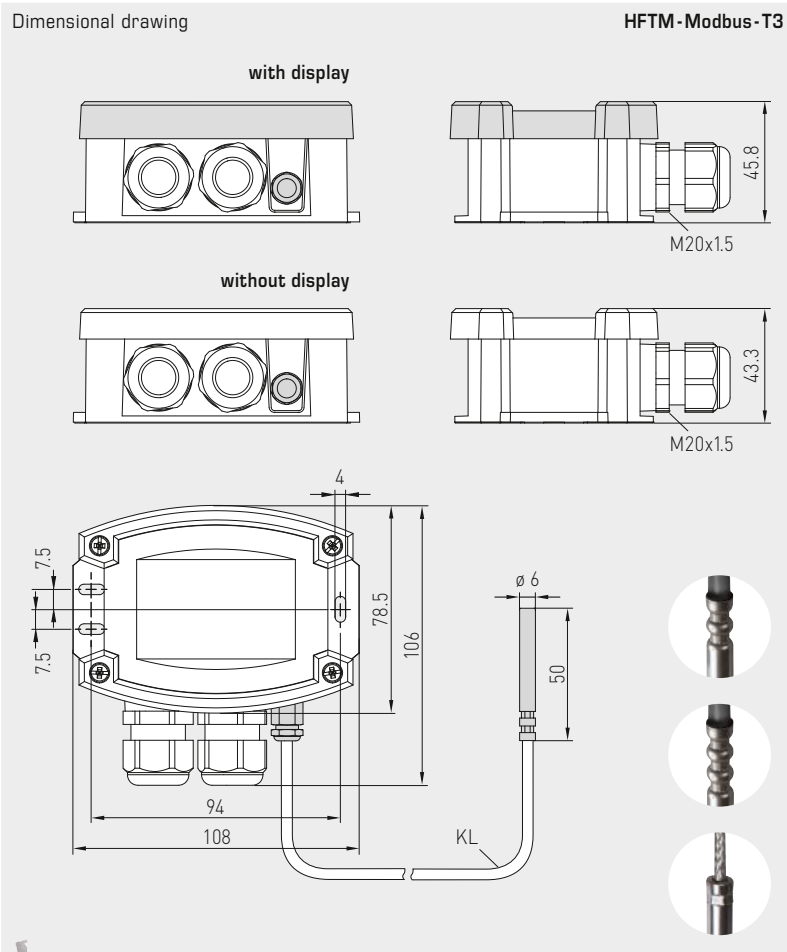

HFTM-Modbus-T3 with display



IP65 (standard)  
humidity-tight

IP68 (optional)  
water-tight  
Perfect Sensor Protection

IP54 (optional)  
with glass fibre cable



High-performance encapsulation against vibration, mechanical stress and humidity



THERMASGARD® HFTM - Modbus - T3 Sleeve sensor with temperature measuring transducer

Type / WG01	Sensor	Output	Type	Display	Item No.	Price
<b>HFTM-Modbus-T3</b>						
HFTM-Modbus-T3	Pt1000	Modbus	Remote sensor		1101-62A6-0210-000	126,25 €
HFTM-Modbus-T3 LCD	Pt1000	Modbus	Remote sensor	■	1101-62A6-4210-000	177,93 €
Extra charge:	Protection type IP68 (sensor sleeve watertight compound-filled) per running metre of connecting lead (silicone/PTFE/glass fibre) other protection sleeve lengths optional				on request	3,24 €
	Cable connection with M12 connector according to DIN EN 61076-2-101				on request	

ACCESSORIES

KA2-Modbus	Communication adapter (USB/RS485) for system connection				1906-1200-0000-100	203,80 €
LA-Modbus	Line termination device (with terminating resistor) as an active bus termination				1906-1300-0000-100	76,01 €
THE-xx	Immersion sleeve, stainless steel V4A (1.4571) or nickel-plated brass, Ø=9mm, inner diameter of socket 5.2mm, with adjusting screw M12x1.5					

For further information, see last chapter Accessories!

Surface contact temperature / tube contact temperature measuring transducers, incl. strap, compact variant, calibratable, with Modbus connection

Calibratable surface-contact temperature measuring transducer (compact variant)  
**THERMASGARD® ALTM1-Modbus-T3** with Modbus connection, in an impact-resistant plastic housing with quick-locking screws, optionally with/without display, incl. strap.

The surface-contact sensor is used to detect the temperature on lines, pipes (e.g., cold and warm water) or on heating sections for heating control.

**Innovative Modbus sensor** with galvanically separated RS485 Modbus interface, selectable bus termination resistance, DIP switch for setting the bus parameters and bus address in current-free state, LEDs for telegram status display, two separate push-in terminals and large three-line display (illuminated, with customised programming in the 7-segment range and dot-matrix range). Uses **internal diagnostics** to detect sensor breakage or sensor short circuit as errors. The error messages can be retrieved via Modbus and are shown on the display. The sensor is factory-calibrated; an environmental precision adjustment by an expert is possible.

ALTM 1 - Modbus-T3



Device version with **M12 connector** (optional on request)



**TECHNICAL DATA**

Voltage supply:	24 V AC (±20%) and 15...36 V DC
Power consumption:	< 1.2 W / 24 V DC; < 1.8 VA / 24 V AC
Sensor:	Pt1000, DIN EN 60751, class B
Measuring range:	-50...+150 °C <b>T<sub>max</sub> up to +100 °C</b> (compact variant)
Temperature deviation:	typically ±0.2 K at +25 °C
Zero point offset:	± 10 °C
Bus protocol:	Modbus (RTU mode), address range 0... <b>247</b> selectable
Signal filtering:	0.3 s / 1 s / 10 s
Housing:	plastic, UV-resistant, material polyamide, 30% glass-globe reinforced, with quick-locking screws (slotted / Phillips head combination), colour traffic white (similar to RAL 9016), housing cover for display is transparent!
Housing dimensions:	108 x 78.5 x 43.3 mm (Tyr 3 without display) 108 x 78.5 x 45.8 mm (Tyr 3 with display)
Cable connection:	<b>cable gland</b> , plastic (2x M20 x 1.5; with strain relief, exchangeable, inner diameter 8 - 13 mm) or <b>M12 connector</b> according to DIN EN 61076-2-101 (optional on request)
Electrical connection:	0.2 - 1.5 mm <sup>2</sup> , using push-in terminals
Process connection:	Endless strap with metal tightener (included in scope of delivery) Ø = 13 - 92 mm (¼ - 3"), L = 300 mm
Ambient temperature:	Measuring transducer -30...+70 °C
Permissible air humidity:	< 95% r. H., non-precipitating air
Protection class:	III (according to EN 60 730)
Protection type:	<b>IP65</b> (according to EN 60 529)
Standards:	CE conformity, electromagnetic compatibility according to EN 61326, according to EMC Directive 2014/30/EU
Equipment:	<b>Display with illumination</b> , three-line, programmable, cutout approx. 51 x 29 mm (W x H), for displaying the actual temperature, error message or an individually programmable display value
Internal diagnostics:	<b>Error 1</b> at sensor breakage <b>Error 2</b> at sensor short circuit
<b>ACCESSORIES</b>	see table

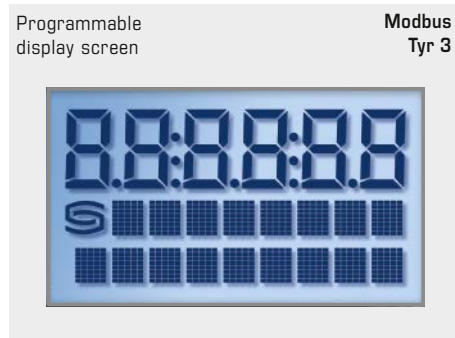
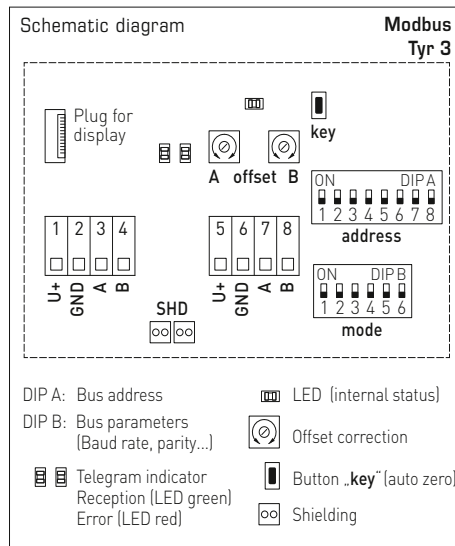



Surface contact temperature / tube contact temperature measuring transducers, incl. strap, compact variant, calibratable, with Modbus connection

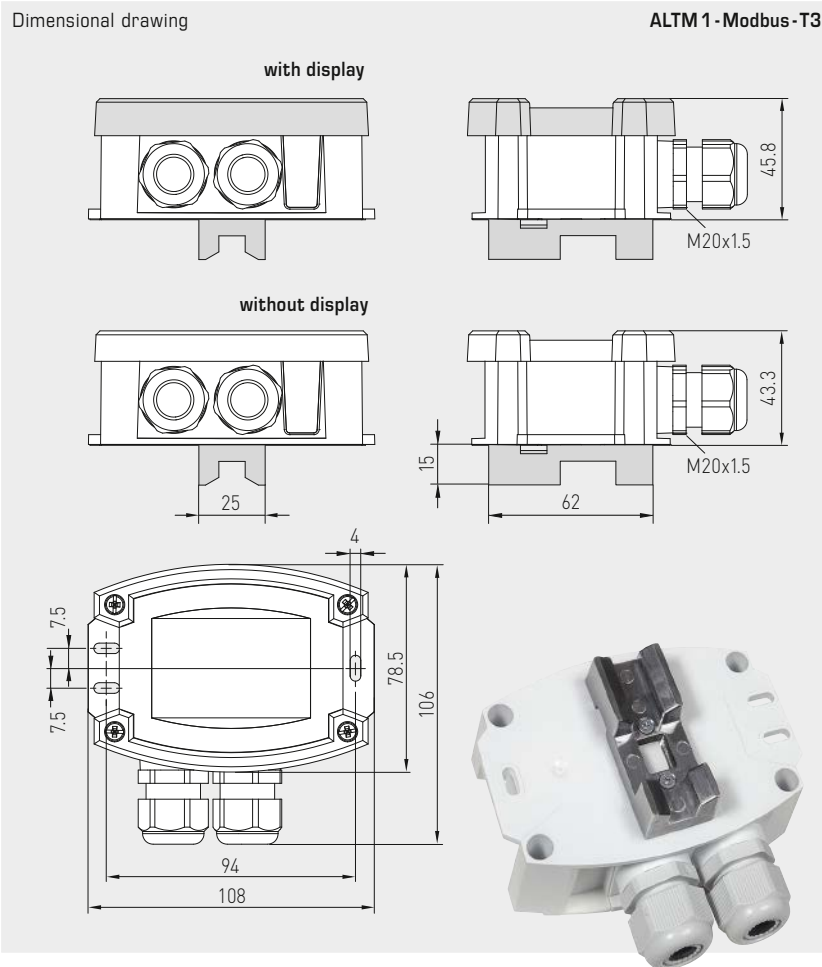

**THERMASGARD® ALTM 1 - Modbus - T3** Surface contact temperature / tube contact temperature measuring transducers

Type / WG01	Sensor	Output	Type	Display	Item No.	Price
<b>ALTM 1 - Modbus - T3</b>						
ALTM1-Modbus-T3	Pt1000	Modbus	Compact		1101-12B6-0000-000	<b>126,76 €</b>
ALTM1-Modbus-T3 LCD	Pt1000	Modbus	Compact	■	1101-12B6-4000-000	<b>179,63 €</b>
Optional:	Cable connection with <b>M12 connector</b> according to DIN EN 61076-2-101				on request	

<b>ACCESSORIES</b>						
<b>KA2-Modbus</b>	<b>Communication adapter</b> (USB/RS485) for system connection				1906-1200-0000-100	<b>203,80 €</b>
<b>LA-Modbus</b>	<b>Line termination device</b> (with terminating resistor) as an active bus termination				1906-1300-0000-100	<b>76,01 €</b>
<b>WLP-1</b>	<b>Heat-conductive paste</b> , silicone-free				7100-0060-1000-000	<b>3,22 €</b>

For further information, see last chapter Accessories!

Surface contact temperature / tube contact temperature measuring transducers, incl. strap, with detached sensor head, calibratable, with Modbus connection

Calibratable surface-contact temperature measuring transducer (detached variant) **THERMASGARD® ALTM2-Modbus-T3** with Modbus connection, in an impact-resistant plastic housing with quick-locking screws, optionally with /without display, cable sensor with a pipe feeder, incl. strap.

The pipe surface-contact sensor is used to detect the temperature on lines, pipes (e.g., cold and warm water) or on heating sections for heating control.

**Innovative Modbus sensor** with galvanically separated RS485 Modbus interface, selectable bus termination resistance, DIP switch for setting the bus parameters and bus address in current-free state, LEDs for telegram status display, two separate push-in terminals and large three-line display (illuminated, with customised programming in the 7-segment range and dot-matrix range). Uses **internal diagnostics** to detect sensor breakage or sensor short circuit as errors. The error messages can be retrieved via Modbus and are shown on the display. The sensor is factory-calibrated; an environmental precision adjustment by an expert is possible.

ALTM 2 - Modbus - T3



Device version with **M12 connector** (optional on request)



**TECHNICAL DATA**

Voltage supply:	24 V AC (± 20%) and 15...36 V DC
Power consumption:	< 1.2 W / 24 V DC; < 1.8 VA / 24 V AC
Sensor:	Pt1000, DIN EN 60751, class B <b>(Perfect Sensor Protection with IP68)</b>
Measuring range:	-50...+150 °C, <b>T<sub>max</sub> to +150 °C</b> (detached sensor variant)
Temperature deviation:	typically ± 0.2 K at +25 °C
Zero point offset:	± 10 °C
Bus protocol:	Modbus (RTU mode), address range 0... <b>247</b> selectable
Signal filtering:	0.3 s / 1 s / 10 s
Medium:	clean air and non-aggressive, non-combustible gases
Sensor protection:	pipe feeder made of stainless steel <b>V4A</b> (1.4571), Ø = 6 mm, L = 50 mm
Sensor cable:	silicone, SiHF, 2 x 0.25 mm <sup>2</sup> , cable length (KL) = 1.5 m (other lengths and range limits optional, e.g. PTFE leads up to + 250 °C or glass fibre with steel wire mesh up to + 350 °C)
Housing:	plastic, UV-resistant, material polyamide, 30 % glass-globe reinforced, with quick-locking screws (slotted / Phillips head combination), colour traffic white (similar to RAL 9016), housing cover for display is transparent!
Housing dimensions:	108 x 78.5 x 43.3 mm (Tyr 3 without display) 108 x 78.5 x 45.8 mm (Tyr 3 with display)
Cable connection:	<b>cable gland</b> , plastic (2x M20 x 1.5; with strain relief, exchangeable, inner diameter 8 - 13 mm) or <b>M12 connector</b> according to DIN EN 61076-2-101 (optional on request)
Electrical connection:	0.2 - 1.5 mm <sup>2</sup> , using push-in terminals
Process connection:	Endless strap with metal tightener (included in scope of delivery) Ø = 13 - 92 mm (¼ - 3"), L = 300 mm
Ambient temperature:	Measuring transducer -30...+70 °C
Permitted humidity:	< 95 % r. H., non-precipitating air
Protection class:	III (according to EN 60 730)
Protection type housing:	<b>IP65</b> (according to EN 60 529)
Protection type sensor:	<b>IP65</b> (according to EN 60 529) <b>sleeve</b> humidity-tight (standard) <b>IP68</b> (according to EN 60 529) <b>sleeve</b> water-tight (optional)
Standards:	CE conformity, electromagnetic compatibility according to EN 61326, according to EMC Directive 2014 / 30 / EU
Equipment:	<b>Display with illumination</b> , three-line, programmable, cutout approx. 51 x 29 mm (W x H), for displaying the actual temperature, error message or an individually programmable display value
Internal diagnostics:	<b>Error 1</b> at sensor breakage <b>Error 2</b> at sensor short circuit
<b>ACCESSORIES</b>	see table

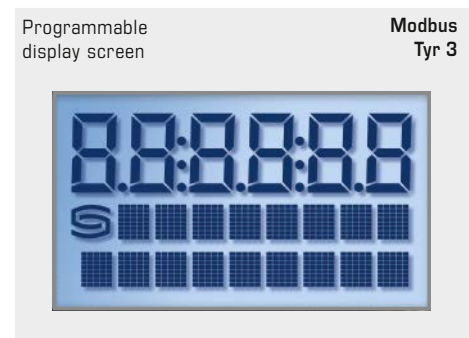
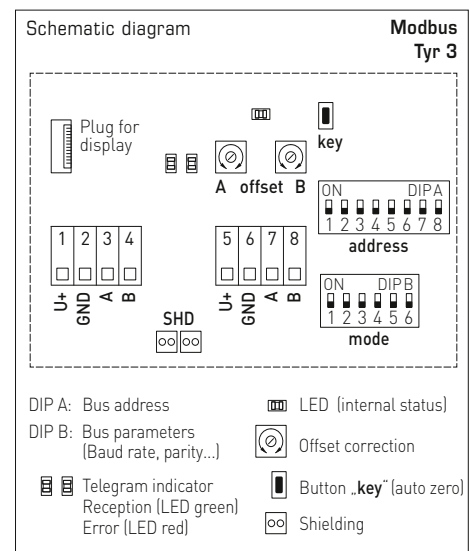





S+S REGELTECHNIK

Surface contact temperature / tube contact temperature measuring transducers,  
incl. strap, with detached sensor head, calibratable,  
with Modbus connection

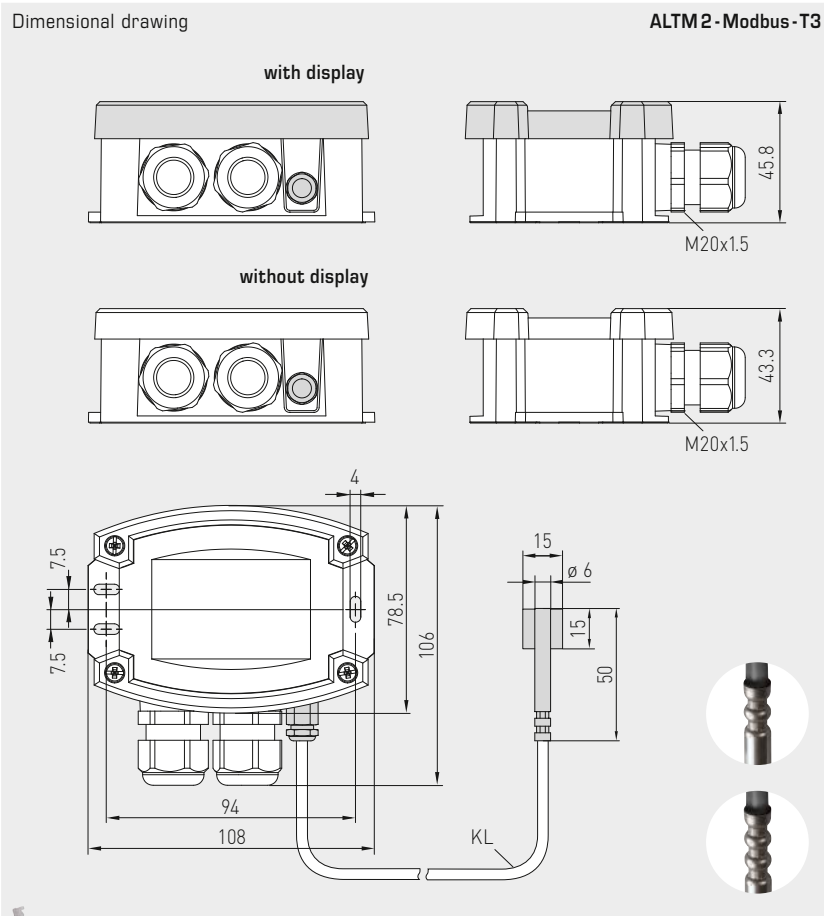

ALTM 2 - Modbus - T3  
with display



**IP65** (standard)  
humidity-tight

**IP68** (optional)  
water-tight  
**Perfect Sensor Protection**



High-performance encapsulation against  
vibration, mechanical stress and humidity



**THERMASGARD® ALTM 2 - Modbus - T3** Surface contact temperature / tube contact temperature measuring transducers

Type / WG01	Sensor	Output	Type	Display	Item No.	Price	
<b>ALTM 2 - Modbus - T3</b>							
ALTM2-Modbus-T3	Pt1000	Modbus	Remote sensor		1101-62B6-0210-000	<b>133,63 €</b>	
ALTM2-Modbus-T3 <b>LCD</b>	Pt1000	Modbus	Remote sensor	■	1101-62B6-4210-000	<b>185,36 €</b>	
Extra charge:	Protection type <b>IP68</b> (sensor sleeve watertight compound-filled) per running metre of connecting lead ( <b>silicone / PTFE / glass fibre</b> ) Cable connection with <b>M12 connector</b> according to DIN EN 61076-2-101					on request on request	<b>3,24 €</b>

**ACCESSORIES**

<b>KA2-Modbus</b>	<b>Communication adapter</b> (USB/RS485) for system connection	1906-1200-0000-100	<b>203,80 €</b>
<b>LA-Modbus</b>	<b>Line termination device</b> (with terminating resistor) as an active bus termination	1906-1300-0000-100	<b>76,01 €</b>
<b>WLP-1</b>	<b>Heat-conductive paste</b> , silicone-free	7100-0060-1000-000	<b>3,22 €</b>

For further information, see last chapter Accessories!

**Pendulum room temperature measuring transducer, (with stainless steel sleeve), calibratable, with Modbus connection**

Calibratable room pendulum temperature measuring transducer (with sleeve)  
**THERMASGARD® RPTM1-Modbus-T3** with Modbus connection, in an impact-resistant plastic housing with quick-locking screws, optionally with /without display, cable sensor with stainless steel sleeve and plastic sinter filter (exchangeable).

The pendulum sensor has been specially designed to detect the temperature in larger rooms or halls. The resistance thermometer achieves a very good representative measurement result due to its positioning in the room.

**Innovative Modbus sensor** with galvanically separated RS485 Modbus interface, selectable termination resistance, DIP switch for setting the bus parameters and bus address in current-free state, LEDs for telegram status display, two separate push-in terminals and large three-line display (illuminated, with customised programming in the 7-segment range and dot-matrix range). Uses **internal diagnostics** to detect sensor breakage or sensor short circuit as errors. The error messages can be retrieved via Modbus and are shown on the display. The sensor is factory-calibrated; an environmental precision adjustment by an expert is possible.

RPTM1-Modbus-T3



Device version with **M12 connector** (optional on request)

**TECHNICAL DATA**

Voltage supply:	24 V AC (±20%) and 15...36V DC
Power consumption:	< 1.2 W / 24 V DC; < 1.8 VA / 24 V AC
Sensor:	Pt1000, DIN EN 60751, class B
Sensor protection:	<b>plastic</b> sinter filter, Ø 16 mm, L = 35 mm, exchangeable (optional <b>metal</b> sinter filter, Ø 16 mm, L = 32 mm)
Measuring range:	-50...+150 °C
Temperature deviation:	typically ± 0.2 K at +25 °C
Zero point offset:	± 10 °C
Ambient temperature:	Measuring transducer -30...+70 °C
Medium:	clean air and non-aggressive, non-combustible gases
Bus protocol:	Modbus (RTU mode), address range 0... <b>247</b> selectable
Signal filtering:	0.3 s / 1 s / 10 s
Housing:	plastic, UV-resistant, material polyamide, 30% glass-globe reinforced, with quick-locking screws (slotted / Phillips head combination), colour traffic white (similar to RAL 9016), housing cover for display is transparent!
Housing dimensions:	108 x 78.5 x 43.3 mm (Tyr3 without display) 108 x 78.5 x 45.8 mm (Tyr3 with display)
Cable connection:	<b>cable gland</b> , plastic (2x M20 x 1.5; with strain relief, exchangeable, inner diameter 8 - 13 mm) <b>or</b> <b>M12 connector</b> according to DIN EN 61076-2-101 (optional on request)
Connection cable:	PVC, H03VV-F, 2 x 0.5 mm <sup>2</sup> , cable length (KL) = approx. 1.5 m (other lengths optional)
Protective tube:	stainless steel <b>V2A</b> (1.4301), Ø=16 mm, NL = 142 mm
Electrical connection:	0.2 - 1.5 mm <sup>2</sup> , using push-in terminals
Permissible air humidity:	< 95 % r. H., non-precipitating air
Protection class:	III (according to EN 60 730)
Protection type:	<b>IP 65</b> (according to EN 60 529)
Standards:	CE conformity, electromagnetic compatibility according to EN 61326, according to EMC Directive 2014 / 30 / EU
Equipment:	<b>Display with illumination</b> , three-line, programmable, cutout approx. 51 x 29 mm (W x H), for displaying the actual temperature, error message or an individually programmable display value
Internal diagnostics:	<b>Error 1</b> at sensor breakage <b>Error 2</b> at sensor short circuit
<b>ACCESSORIES</b>	see table

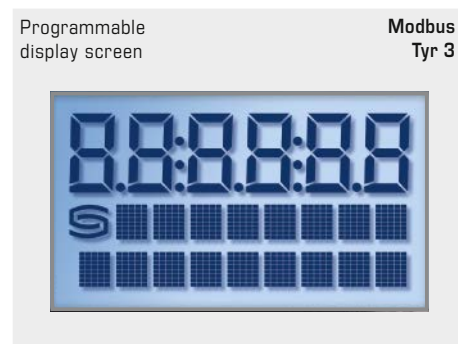
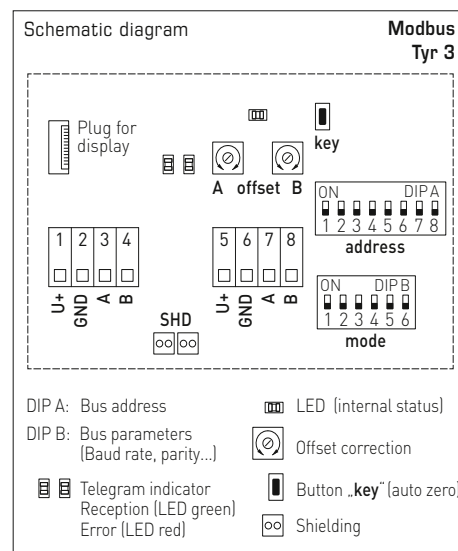

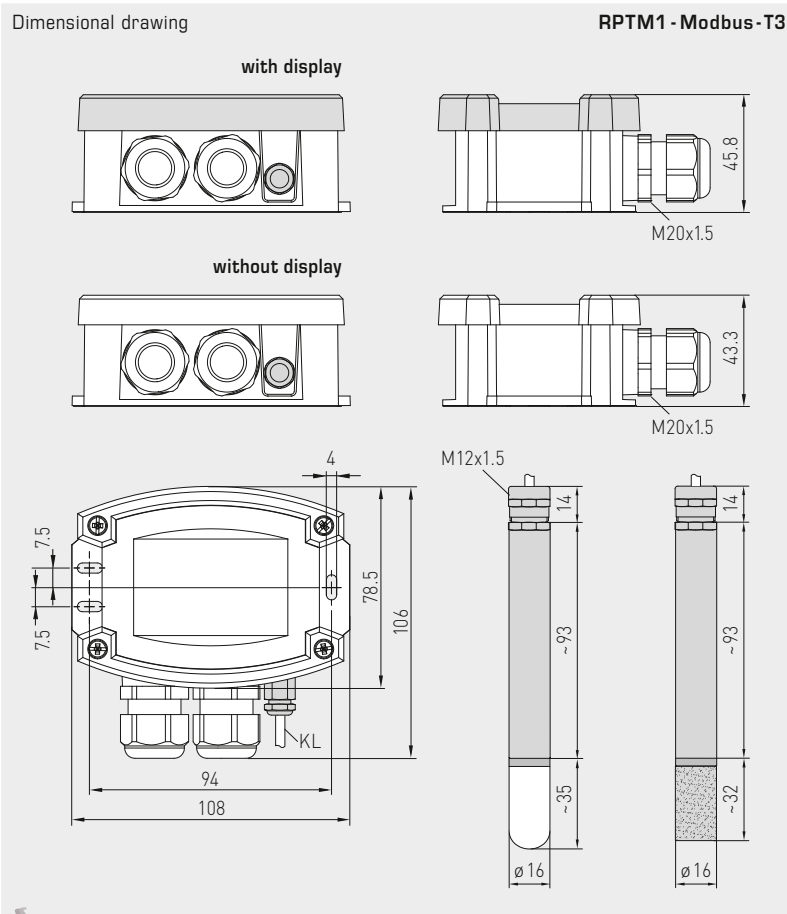

RPTM1 - Modbus - T3  
with display



MF-16-K  
Mounting flange,  
plastic (optional)



SF-K  
with plastic sinter filter  
(standard)



SF-M  
with metal sinter filter  
(optional)



THERMASGARD® RPTM1 - Modbus - T3 Pendulum room temperature measuring transducer (with stainless steel sleeve)

Type / WG01	Sensor	Output	Type	Display	Item No.	Price
<b>RPTM1 - Modbus - T3</b>						
RPTM1-Modbus-T3	Pt1000	Modbus	Remote sensor		1101-6286-0210-000	<b>167,36 €</b>
RPTM1-Modbus-T3 LCD	Pt1000	Modbus	Remote sensor	■	1101-6286-4210-000	<b>219,52 €</b>
Extra charge:	per running metre of connecting lead (PVC)				on request	
	Cable connection with <b>M12 connector</b> according to DIN EN 61076-2-101				on request	

ACCESSORIES

KA2-Modbus	Communication adapter (USB/RS485) for system connection				1906-1200-0000-100	<b>203,80 €</b>
LA-Modbus	Line termination device (with terminating resistor) as an active bus termination				1906-1300-0000-100	<b>76,01 €</b>
SF-M	Metal sinter filter, Ø 16 mm, L = 32 mm, exchangeable stainless steel V4A (1.4404)				7000-0050-2200-100	<b>40,31 €</b>
MF-16-K	Mounting flange plastic (optional)				7100-0030-0000-000	<b>9,10 €</b>

For further information, see last chapter Accessories!

**Pendulum room temperature measuring transducer, (with globe), calibratable, with Modbus connection**

Calibratable room pendulum temperature measuring transducer (with globe) **THERMASGARD® RPTM2 - Modbus - T3** with Modbus connection, in an impact-resistant plastic housing with quick-locking screws, optionally with /without display, cable sensor with a black plastic globe.

The pendulum sensor has been specially designed to detect the temperature in larger rooms or halls. The resistance thermometer (globe thermometer) achieves a very good, representative measurement result due to its positioning in the room. The dark radiation sensor determines the effective radiation heat at the measured location. This is relevant for calculating the thermal comfort (operative room temperature) taking into account the co-action of thermal radiation and thermal convection. The ratio of globe temperature / air temperature is approx. 70% / 30%.

**Innovative Modbus sensor** with galvanically separated RS485 Modbus interface, selectable bus termination resistance, DIP switch for setting the bus parameters and bus address in current-free state, LEDs for telegram status display, two separate push-in terminals and large three-line display (illuminated, with customised programming in the 7-segment range and dot-matrix range). Uses **internal diagnostics** to detect sensor breakage or sensor short circuit as errors. The error messages can be retrieved via Modbus and are shown on the display. The sensor is factory-calibrated; an environmental precision adjustment by an expert is possible.

RPTM2 - Modbus - T3



Device version with **M12 connector** (optional on request)



**TECHNICAL DATA**

Voltage supply:	24 V AC (± 20%) and 15...36 V DC
Power consumption:	< 1.2 W / 24 V DC; < 1.8 VA / 24 V AC
Sensor:	Pt1000, DIN EN 60751, class B
Measuring range:	-50...+150 °C <b>T<sub>min</sub> -50 °C, T<sub>max</sub> +80 °C</b>
Temperature deviation:	typically ± 0.2 K at +25 °C
Zero point offset:	± 10 °C
Ambient temperature:	Measuring transducer -30...+70 °C
Medium:	clean air and non-aggressive, non-combustible gases
Bus protocol:	Modbus (RTU mode), address range 0... <b>247</b> selectable
Signal filtering:	0.3 s / 1 s / 10 s
Housing:	plastic, UV-resistant, material polyamide, 30% glass-globe reinforced, with quick-locking screws (slotted / Phillips head combination), colour traffic white (similar to RAL 9016), housing cover for display is transparent!
Housing dimensions:	108 x 78.5 x 43.3 mm (Tyr 3 without display) 108 x 78.5 x 45.8 mm (Tyr 3 with display)
Cable connection:	<b>cable gland</b> , plastic (2x M20 x 1.5; with strain relief, exchangeable, inner diameter 8 - 13 mm) or <b>M12 connector</b> according to DIN EN 61076-2-101 (optional on request)
Connection cable:	PVC, H03VV-F, 2 x 0.5 mm <sup>2</sup> , cable length (KL) = approx. 1.5 m (other lengths optional)
Globe:	plastic, colour black, Ø = 50 mm
Electrical connection:	0.2 - 1.5 mm <sup>2</sup> , using push-in terminals
Permissible air humidity:	< 95% r. H., non-precipitating air
Protection class:	III (according to EN 60 730)
Protection type:	<b>IP 65</b> (according to EN 60 529)
Standards:	CE conformity, electromagnetic compatibility according to EN 61326, according to EMC Directive 2014 / 30 / EU
Equipment:	<b>Display with illumination</b> , three-line, programmable, cutout approx. 51 x 29 mm (W x H), for displaying the actual temperature, error message or an individually programmable display value
Internal diagnostics:	<b>Error 1</b> at sensor breakage <b>Error 2</b> at sensor short circuit
<b>ACCESSORIES</b>	see table

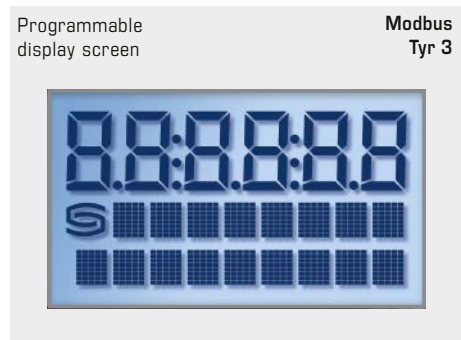
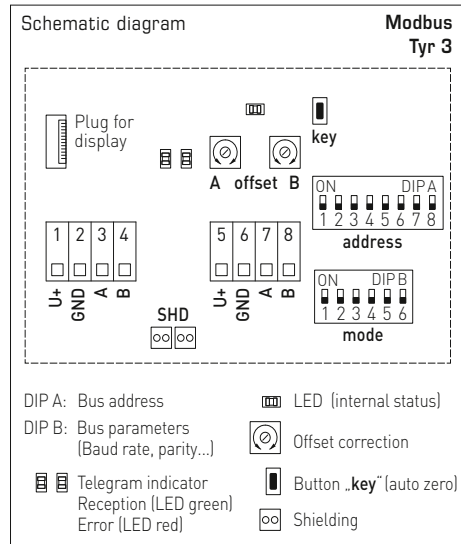





S+S REGELTECHNIK

Pendulum room temperature measuring transducer,  
(with globe), calibratable,  
with Modbus connection

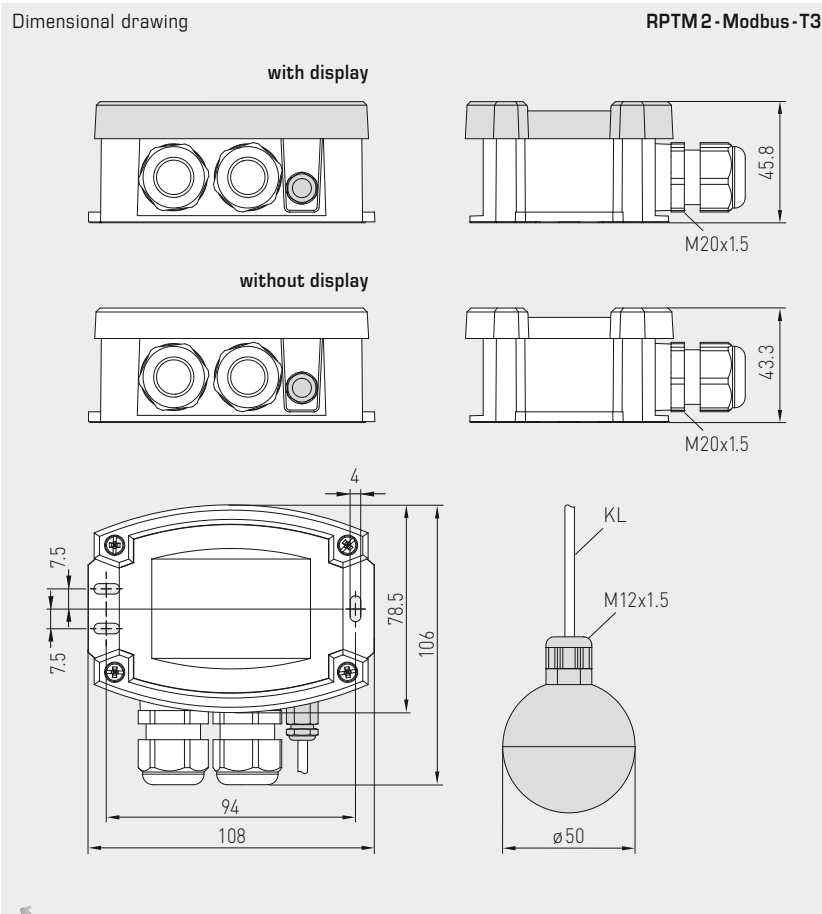

RPTM2 - Modbus - T3  
with display



THERMASGARD® RPTM 2 - Modbus - T3 Pendulum room temperature measuring transducer (with globe)						
Type / WG01	Sensor	Output	Type	Display	Item No.	Price
<b>RPTM2 - Modbus - T3</b>						
RPTM2-Modbus-T3	Pt1000	Modbus	Remote sensor		1101-6296-0210-000	<b>173,58 €</b>
RPTM2-Modbus-T3 LCD	Pt1000	Modbus	Remote sensor	■	1101-6296-4210-000	<b>225,83 €</b>
Extra charge:	per running metre of connecting lead (PVC)				on request	
	Cable connection with <b>M12 connector</b> according to DIN EN 61076-2-101				on request	

ACCESSORIES						
<b>KA2-Modbus</b>	<b>Communication adapter</b> (with USB and RS485 interface) for system connection (incl. quick-start software)				1906-1200-0000-100	<b>203,80 €</b>
<b>LA-Modbus</b>	<b>Line termination device</b> (with terminating resistor) as an active bus termination of RS485 networks				1906-1300-0000-100	<b>76,01 €</b>

**Room humidity and temperature sensor ( $\pm 2.0\%$ ), on-wall,  
for temperature, relative / absolute humidity, dew point, mixture ratio, enthalpy,  
calibratable, with Modbus connection**

**RFTF-Modbus  
Standard**

The calibratable room sensor **HYGRASGARD® RFTF-Modbus** with Modbus connection, with/without optional display in an elegant housing (Baldur 2) measures the relative humidity and temperature of the room air. These measurands are used to internally calculate various parameters. The Modbus can be used to retrieve the following parameters: relative humidity [% r. H.], absolute humidity [g/m<sup>3</sup>], mixture ratio [g/kg], dew point temperature [°C], enthalpy [kJ/kg] (ignoring atmospheric air pressure) and room temperature [°C].



TECHNICAL DATA	
Power supply:	24 V AC ( $\pm 20\%$ ) and 15...36 V DC
Power consumption:	< 1 VA / 24 V DC, < 2.2 VA / 24 V AC
Sensor:	<b>Digital humidity sensor with integrated temperature sensor,</b> low hysteresis, high long-term stability
Data points:	Temperature, relative humidity, absolute humidity, dew point, mixture ratio, enthalpy and setpoint potentiometer, rotary switch and presence button
Measuring range:	0...100% r.H. (humidity) 0...+50 °C (temperature)
Deviation, humidity:	typically $\pm 2.0\%$ (20...80% r. H.) at +25 °C, otherwise $\pm 3.0\%$
Temperature deviation:	typically $\pm 0.2$ K at +25 °C
Zero point offset:	$\pm 10\%$ r.H. (humidity) $\pm 10$ °C (temperature) adjustable using potentiometer
Ambient temperature:	Storage -35...+85 °C; Operation 0...+50 °C
Medium:	clean air and other <b>non-aggressive</b> , non-combustible gases
Bus protocol:	Modbus (RTU mode), address range 0... <b>247</b> selectable
Signal filtering:	4 s / 32 s
Housing:	plastic, material ABS, colour pure white (similar to RAL 9010)
Dimensions:	98 x 98 x 33 mm (Baldur 2)
Installation:	wall mounting or on in-wall flush box, $\varnothing$ 55 mm, base with 4 holes, for attachment to vertically or horizontally installed in-wall flush boxes for rear cable entry, with predetermined breaking point for cable entry from top/bottom in case of plain on-wall installation
Long-term stability:	$\pm 1\%$ / year
Permissible air humidity:	< 95% r. H., non-precipitating air
Protection class:	III (according to EN 60 730)
Protection type:	<b>IP30</b> (according to EN 60 529)
Standards:	CE conformity according to EMC Directive 2014/30/EU, according to EN 61 326
Features:	<b>Display with illumination</b> , two-line, programmable, cutout approx. 36 x 15 mm (W x H), to display actual humidity and temperature or a selectable parameter or an individually programmable display value
<b>ACCESSORIES</b>	see table

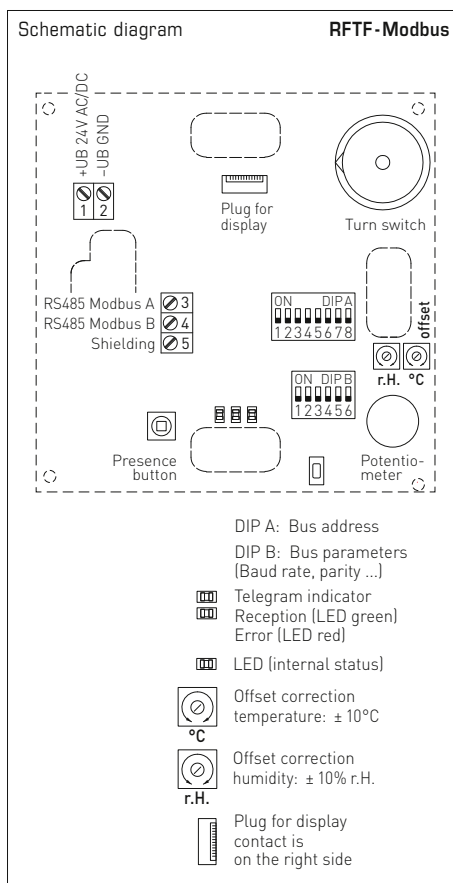
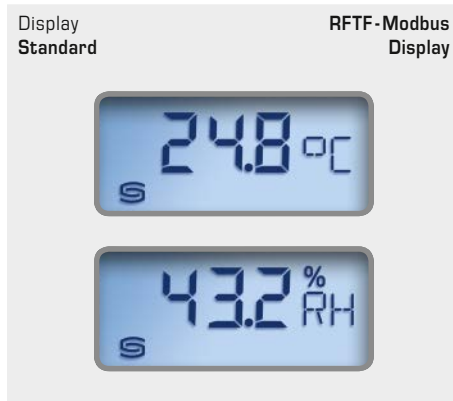



S+S REGELTECHNIK

Room humidity and temperature sensor ( $\pm 2.0\%$ ), on-wall,  
for temperature, relative / absolute humidity, dew point, mixture ratio, enthalpy,  
calibratable, with Modbus connection

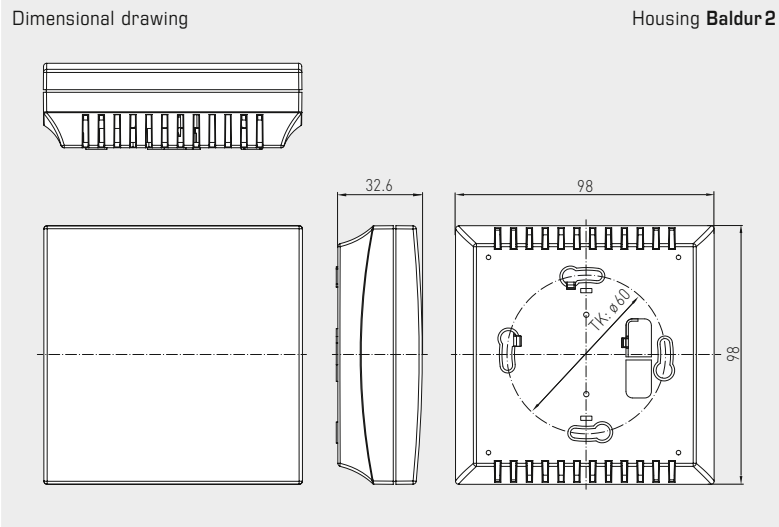

RFTF-Modbus  
with display



By default, the display alternates between the **actual temperature** and the **actual humidity** (relative humidity). For improved legibility, backlighting is provided.

The Modbus interface allows the display to be **individually** configured both in the 7-segment area and in the dot-matrix area.

The **Modbus configuration** can be used to program an alternative output variable instead of the standard display.

In this case, the first line displays the value and index while the second line displays the corresponding unit.

The index identifies the display type:

- Index 1** = temperature in °C
- Index 2** = setpoint potentiometer in %
- Index 3** = dew point in °C
- Index 4** = relative humidity in % r.H.
- Index 5** = absolute humidity in g/m<sup>3</sup>
- Index 6** = mixture ratio in g/kg
- Index 7** = enthalpy in kJ/kg

HYGRASGARD® RFTF-Modbus		Room humidity and temperature sensor					
Type / WG01	Measuring Range / Readout	Temperature	Output	Display	Item No.	Price	
<b>RFTF-Modbus</b>							
RFTF-Modbus	0...100 % r. H. (default) 0...80 g / kg (MR) 0...80 g / m <sup>3</sup> (A.H.) 0...85 kJ / kg (ENT.) -20...+80 °C (DP)	0...+50 °C	Modbus		1201-42B6-6000-000	156,39 €	
RFTF-Modbus LCD	0...100 % r. H. (default) 0...80 g / kg (MR) 0...80 g / m <sup>3</sup> (A.H.) 0...85 kJ / kg (ENT.) -20...+80 °C (DP)	0...+50 °C	Modbus	■	1201-42B6-7000-000	192,77 €	
<b>ACCESSORIES</b>							
<b>KA2-Modbus</b>	<b>Communication adapter</b> (with USB and RS485 interface) for system connection (incl. quick-start software)				1906-1200-0000-100	203,80 €	
<b>LA-Modbus</b>	<b>Line termination device</b> (with terminating resistor) as an active bus termination of RS485 networks				1906-1300-0000-100	76,01 €	

**Room, humidity and temperature sensor or measuring transducer for temperature, relative / absolute humidity, dew point, mixture ratio, enthalpy, in-wall in the panel switch programme, with Modbus connection**

The room sensor and measuring transducer **HYGRASGARD® FSFTM - Modbus** in the in-wall housing, optionally with potentiometer, is used to measure the relative humidity and temperature of the air, and for setpoint adjustment. The following parameters are calculated internally from the measured values: relative humidity [% r. H.], absolute humidity [g/m³], mixture ratio [g/kg], dew point temperature [°C], enthalpy [kJ/kg] (ignoring atmospheric air pressure) and room temperature [°C]. The parameters are queried via the Modbus interface.

A digital, long-term stable sensor is used for humidity and temperature measurement. Relative humidity [% r. H.] is the quotient of water vapour partial pressure divided by the saturation vapour pressure at the respective gas temperature.

The in-wall sensor is mounted in high-quality panel switch programmes, ideally of the brands Gira, Berker, Merten, Jung, Siemens or Busch-Jaeger (using in-wall adapters, no setpoint adjustment possible) either individually or in combination with light switches, socket outlets, etc.

It is used in non-aggressive, dust-free environments, in refrigeration, air conditioning and clean room technology, and in interior rooms, such as living rooms, offices, hotels, etc.

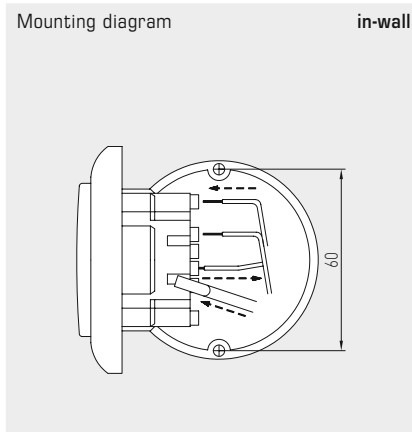

**TECHNICAL DATA**

Power supply:	24 V AC / DC (± 10 %)
Power consumption:	< 1.1 W / 24 V DC ; < 2.2 VA / 24 V AC
Data points:	temperature [°C], relative humidity [% r. H.] absolute humidity [g/m³], dew point [°C], mixing ratio [g/kg], enthalpy [kJ/kg] and setpoint potentiometer (no setpoint adjustment possible with Busch-Jaeger)
Bus protocol:	Modbus (RTU mode), address range 0...247 selectable
Signal filtering:	4 s / 32 s

**HUMIDITY**

Sensor:	<b>digital humidity sensor, with integrated temperature sensor, low hysteresis, high long-term stability</b>
Long-term stability:	± 1 % per year
Measuring range, humidity::	0...100% r. H.
Operating range, humidity:	0...95% r. H. (non-precipitating air)
Deviation, humidity:	typically ± 3.0 % (20...80% r. H.) at +25 °C, otherwise ± 5.0 %

**TEMPERATURE**

Measuring range:	0...+50 °C
Deviation, temperature:	typically ± 0.8 K at +25 °C

Mounting:	in-wall flush box Ø 55 mm
Electrical connection:	1.0-2.5 mm², via plug terminals
Ambient temperature:	Storage -35...+85 °C; Operation 0...+50 °C
Permitted humidity:	max. 90% r.H., non-precipitating air
Medium:	clean air and other non-aggressive, non-combustible gases
Protection class:	III (according to EN 60 730)
Protection type:	<b>IP 20</b> (according to 60 529)
Standards:	CE-conformity, electromagnetic compatibility according to EN 61 326, EMC Directive 2014 / 30 / EU

**SWITCH PROGRAMME**

Manufacturer:	GIRA System 55 (other switch programmes, manufacturers, colours as well as prices available upon request)
Housing:	plastic, the standard colour is pure glossy white (similar to RAL 9010) (other colours are available upon request with colour variants depending on the respective light switch programme)

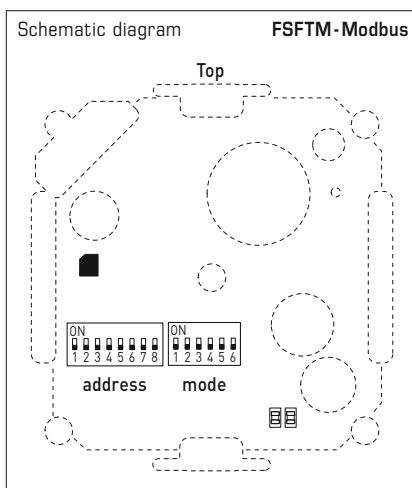
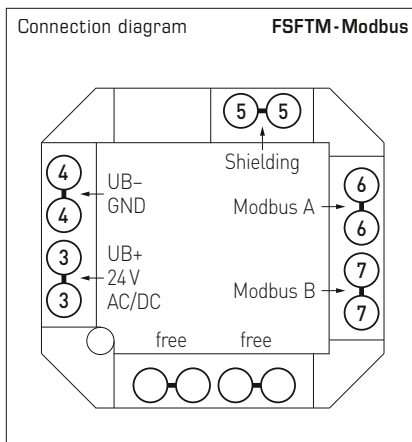





S+S REGELTECHNIK

Room, humidity and temperature sensor or measuring transducer for temperature, relative / absolute humidity, dew point, mixture ratio, enthalpy, in-wall in the panel switch programme, with Modbus connection

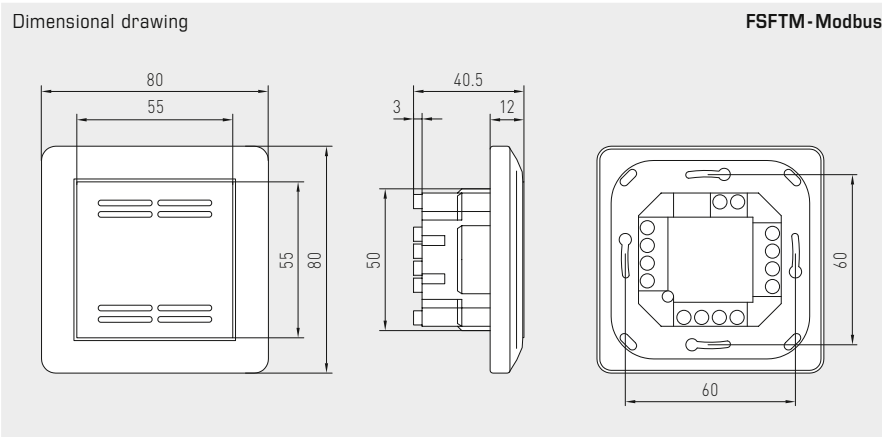

FSFTM-Modbus Standard

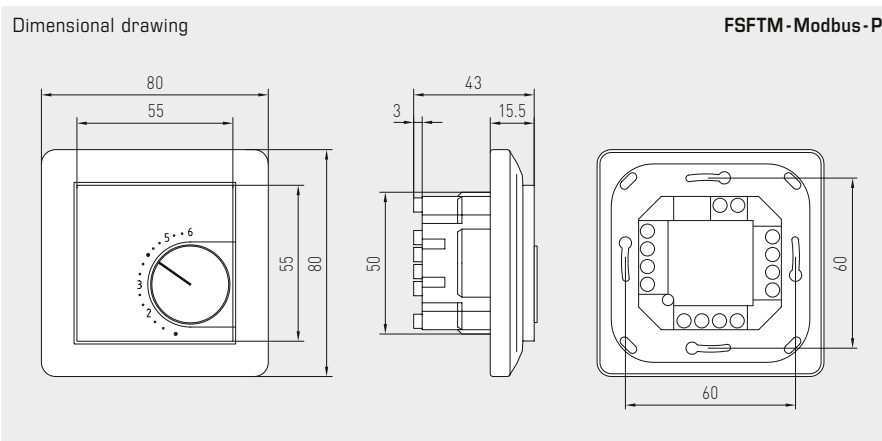

FSFTM-Modbus-P with potentiometer



**HYGRASGARD® FSFTM-Modbus** Room temperature and humidity sensor, in-wall

Type / WG02	Measuring Range	Temperature	Control element	Output	Item No.	Price
<b>FSFTM-Modbus</b>	Humidity (base value)					
FSFTM-Modbus	0...100% r. H. (default) 0...80 g / kg (MV) 0...80 g / m <sup>3</sup> (a.F.) 0...85 kJ / kg (ENT.) -20...+80 °C (TP)	0...+50 °C	-	Modbus	1201-9226-1000-162	<b>276,64 €</b>
FSFTM-Modbus P	0...100% r. H. (default) 0...80 g / kg (MV) 0...80 g / m <sup>3</sup> (a.F.) 0...85 kJ / kg (ENT.) -20...+80 °C (TP)	0...+50 °C	Potentiometer	Modbus	1201-9226-1400-282	<b>299,22 €</b>

**Data points:** relative humidity [% r. H.], absolute humidity [g/m<sup>3</sup>], mixture ratio [g/kg], dew point temperature [°C], enthalpy [kJ/kg] (ignoring atmospheric air pressure), temperature [°C] and setpoint potentiometer

ACCESSORIES						
<b>KA2-Modbus</b>	<b>Communication adapter</b> (with USB and RS485 interface) for system connection (incl. quick-start software)				1906-1200-0000-100	<b>203,80 €</b>
<b>LA-Modbus</b>	<b>Line termination device</b> (with terminating resistor) as an active bus termination of RS485 networks				1906-1300-0000-100	<b>76,01 €</b>

**On-wall-humidity- and temperature sensors ( $\pm 2.0\%$ ),  
for mixture ratio, relative/absolute humidity, dew point, enthalpy  
and temperature, calibratable, with Modbus connection**

Calibratable outside humidity and temperature sensor **HYGRASGARD® AFTF-Modbus-T3** with Modbus connection, in an impact-resistant plastic housing with quick-locking screws, optionally with/without display, with a plastic sinter filter (exchangeable).

The sensor is used to detect various parameters in humidity measurement. It measures the relative humidity (0...100% r.H.) and the temperature ( $-35...+80\text{ }^{\circ}\text{C}$ ) of the ambient air. These measurands are used to internally calculate the following parameters that can be retrieved via Modbus: relative humidity [% r.H.], absolute humidity [ $\text{g}/\text{m}^3$ ], mixture ratio [ $\text{g}/\text{kg}$ ], dew point temperature [ $^{\circ}\text{C}$ ], enthalpy [ $\text{kJ}/\text{kg}$ ] (ignoring atmospheric air pressure) and ambient temperature [ $^{\circ}\text{C}$ ]. A long-term stable, digital sensor guarantees exact measurement results.

The on-wall sensor is applied in a non-aggressive, dust-free environment. It is used in the refrigeration, air conditioning and clean room technology, engineering rooms, hotels and conference facilities.

**Innovative Modbus sensor** with galvanically separated RS485-Modbus-interface, selectable bus termination resistance, DIP switch for setting the bus parameters and bus address in current-free state, LEDs for telegram status display, two separate push-in terminals and large three-line display (illuminated; with customised programming in the 7-segment and dot-matrix range). The sensor is factory-calibrated; an environmental precision adjustment by an expert is possible.

**AFTF-Modbus-T3**



Device version with **M12 connector** (optional on request)



## TECHNICAL DATA

Voltage supply:	24 V AC ( $\pm 20\%$ ) and 15...36 V DC
Power consumption:	< 1.2 W / 24 V DC; < 1.8 VA / 24 V AC
Data points:	Temperature [ $^{\circ}\text{C}$ ], relative humidity [% r.H.], dew point [ $^{\circ}\text{C}$ ], absolute humidity [ $\text{g}/\text{m}^3$ ], mixture ratio [ $\text{g}/\text{kg}$ ], enthalpy [ $\text{kJ}/\text{kg}$ ]
Sensors:	<b>digital humidity sensor with integrated temperature sensor</b> , low hysteresis, high long-term stability
Sensor protection:	plastic sinter filter, $\varnothing$ 14 mm, L = 25 mm, exchangeable
Measuring range:	0...100% r.H. (humidity) $-35...+80\text{ }^{\circ}\text{C}$ (temperature)
Deviation, humidity:	typically $\pm 2.0\%$ (20...80% r.H.) at $+25\text{ }^{\circ}\text{C}$ , otherwise $\pm 3.0\%$
Temperature deviation:	typically $\pm 0.4\text{ K}$ at $+25\text{ }^{\circ}\text{C}$
Zero point offset:	$\pm 10\%$ r.H. (humidity); $\pm 5\text{ }^{\circ}\text{C}$ (temperature)
Ambient temperature:	$-30...+70\text{ }^{\circ}\text{C}$
Medium:	clean air and non-aggressive, non-combustible gases
Bus protocol:	Modbus (RTU mode), address range 0...247 selectable
Housing:	plastic, UV-resistant material polyamide, 30% glass-globe reinforced, with quick-locking screws (slotted / Phillips head combination), colour traffic white (similar to RAL 9016), housing cover for display is transparent!
Housing dimensions:	108 x 78.5 x 43.3 mm (Tyr 3 without display) 108 x 78.5 x 45.8 mm (Tyr 3 with display)
Cable connection:	<b>cable gland</b> , plastic (2x M20 x 1.5; with strain relief, exchangeable, inner diameter 8 - 13 mm) or <b>M12 connector</b> according to DIN EN 61076-2-101 (optional on request)
Process connection:	by screws
Electrical connection:	0.2 - 1.5 mm <sup>2</sup> , using push-in terminals
Long-term stability:	$\pm 1\%$ / year
Permissible air humidity:	< 95% r.H., non-precipitating air
Protection class:	III (according to EN 60 730)
Protection type:	<b>IP 65</b> (according to EN 60 529)
Standards:	CE conformity, electromagnetic compatibility according to EN 61326, according to EMC Directive 2014 / 30 / EU
Optional:	<b>Display with illumination</b> , three-line, programmable, cutout approx. 51 x 29 mm (W x H), for displaying the actual humidity and actual temperature (cyclic) or a selectable parameter (static) or an individually programmable display value
<b>ACCESSORIES</b>	see table

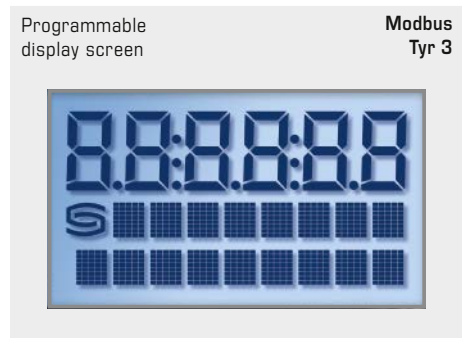
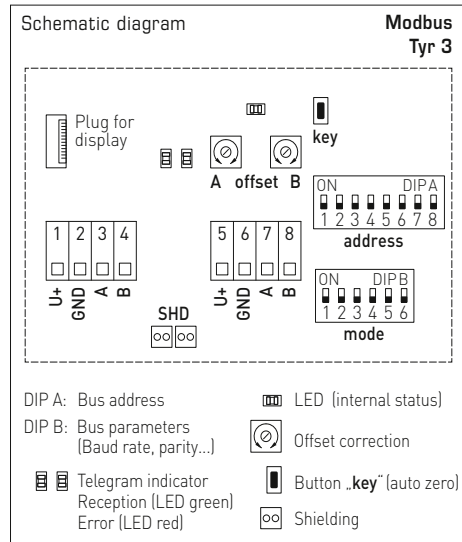



S+S REGELTECHNIK

On-wall-humidity- and temperature sensors ( $\pm 2.0\%$ ),  
for mixture ratio, relative/absolute humidity, dew point, enthalpy  
and temperature, calibratable, with Modbus connection

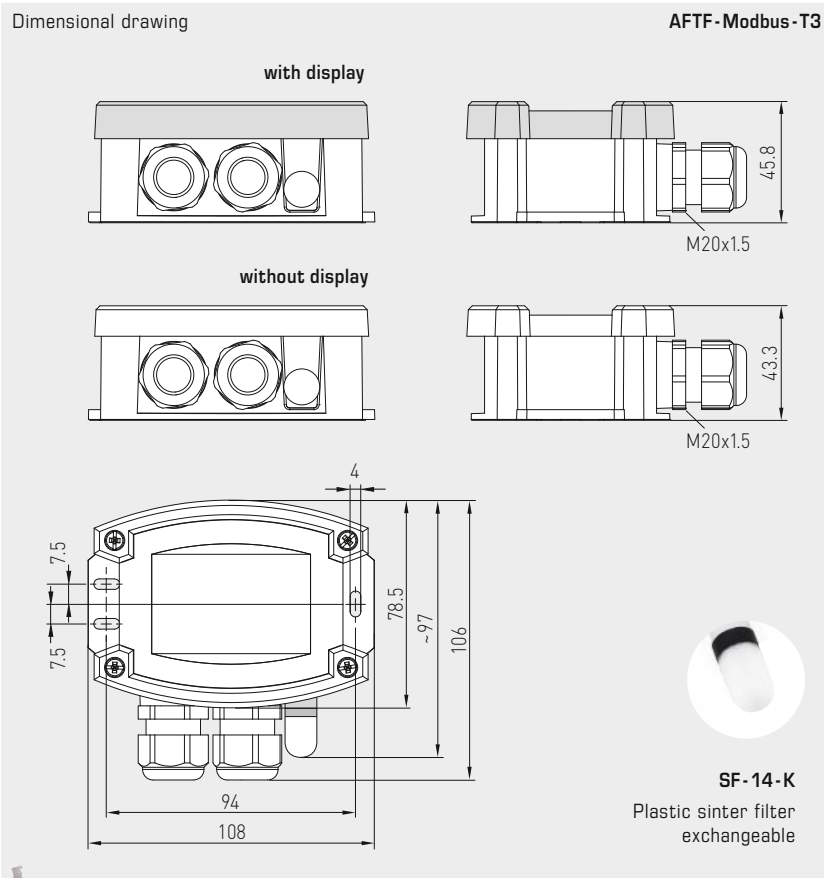

AFTF-Modbus-T3  
with display



SF-14-K  
Plastic sinter filter  
exchangeable

WS-04  
Weather and sun  
protection hood  
(optional)



HYGRASGARD® AFTF - Modbus - T3 On-wall-humidity- and temperature sensors ( $\pm 2.0\%$ )

Type / WG01	Measuring Range / Readout Humidity (switchable)	Temperature	Output	Display	Item No.	Price
<b>AFTF - Modbus - T3</b>						
AFTF-Modbus-T3	0 ... 100% r. H. (default) 0 ... 80 g / kg (MV) 0 ... 80 g / m <sup>3</sup> (a.F.) 0 ... 85 kJ / kg (ENT.) -20 ... +80 °C (TP)	-35 ... +80 °C	Modbus		1201-12C6-1000-000	201,05 €
AFTF-Modbus-T3 LCD	(5x as above)	(1x as above)	Modbus	■	1201-12C6-1400-000	253,44 €
Optional:	Cable connection with <b>M12 connector</b> according to DIN EN 61076-2-101				on request	

ACCESSORIES						
<b>KA2-Modbus</b>	<b>Communication adapter</b> (USB/RS485) for system connection				1906-1200-0000-100	203,80 €
<b>LA-Modbus</b>	<b>Line termination device</b> (with terminating resistor) as an active bus termination				1906-1300-0000-100	76,01 €
<b>WS-01</b>	<b>Sun and ball-impact protection hood</b> , 184 x 180 x 80 mm, stainless steel <b>V2A</b> (1.4301)				7100-0040-2000-000	30,26 €
<b>WS-04</b>	<b>Weather and sun protection hood</b> , 130 x 180 x 135 mm, stainless steel <b>V2A</b> (1.4301)				7100-0040-7000-000	35,70 €

For further information, see last chapter Accessories!

# HYGRASGARD® KFTF-Modbus-T3

## HYGRASGARD® KFTF-20-Modbus-T3



S+S REGELTECHNIK

Duct humidity- and temperature sensors ( $\pm 1.8\%$  /  $\pm 2.0\%$ ), incl. mounting flange, for mixture ratio, relative / absolute humidity, dew point, enthalpy and temperature, calibratable, with Modbus connection

Calibratable duct humidity and temperature sensor **HYGRASGARD® KFTF-Modbus-T3** ( $\pm 2.0\%$ ) or **KFTF-20-Modbus-T3** ( $\pm 1.8\%$ ), with Modbus connection, in an impact-resistant plastic housing with quick-locking screws, optionally with /without display, with a plastic sinter filter (exchangeable), incl. mounting flange.

The sensor is used to detect various parameters in humidity measurement. It measures the relative humidity (0...100% r.H.) and the temperature ( $-35...+80\text{ }^\circ\text{C}$ ) of the ambient air. These measurands are used to internally calculate the following parameters that can be retrieved via Modbus: relative humidity [% r.H.], absolute humidity [ $\text{g}/\text{m}^3$ ], mixture ratio [ $\text{g}/\text{kg}$ ], dew point temperature [ $^\circ\text{C}$ ], enthalpy [ $\text{kJ}/\text{kg}$ ] (ignoring atmospheric air pressure) and ambient temperature [ $^\circ\text{C}$ ]. A long-term stable, digital sensor guarantees exact measurement results. The duct sensor is applied in a non-aggressive, dust-free environment and is suitable for installation in ceilings, ducts and devices. It is used in the refrigeration, air conditioning and clean room technology, engineering rooms, hotels and conference facilities.

**Innovative Modbus sensor** with galvanically separated RS485-Modbus-interface, selectable bus termination resistance, DIP switch for setting the bus parameters and bus address in current-free state, LEDs for telegram status display, two separate push-in terminals and large three-line display (illuminated; with customised programming in the 7-segment and dot-matrix range). The sensor is factory-calibrated; an environmental precision adjustment by an expert is possible.

**KFTF-Modbus-T3** ( $\pm 2.0\%$ )  
**KFTF-20-Modbus-T3** ( $\pm 1.8\%$ )



Device version with **M12 connector** (optional on request)



### TECHNICAL DATA

Voltage supply:	24 V AC ( $\pm 20\%$ ) and 15...36 V DC
Power consumption:	< 1.2 W / 24 V DC; < 1.8 VA / 24 V AC
Data points:	Temperature [ $^\circ\text{C}$ ], relative humidity [% r.H.], dew point [ $^\circ\text{C}$ ], absolute humidity [ $\text{g}/\text{m}^3$ ], mixture ratio [ $\text{g}/\text{kg}$ ], enthalpy [ $\text{kJ}/\text{kg}$ ]
Sensor:	<b>digital humidity sensor with integrated temperature sensor</b> , low hysteresis, high long-term stability
Sensor protection:	<b>plastic sinter filter</b> , $\varnothing$ 16 mm, L = 35 mm, exchangeable (optional <b>metal sinter filter</b> , $\varnothing$ 16 mm, L = 32 mm)
Measuring range:	0...100% r.H. (humidity) $-35...+80\text{ }^\circ\text{C}$ (temperature)
Deviation, humidity:	<b>KFTF-Modbus:</b> typically $\pm 2.0\%$ (20...80% r.H.) at $+25\text{ }^\circ\text{C}$ , otherwise $\pm 3.0\%$ <b>KFTF-20-Modbus:</b> typically $\pm 1.8\%$ (10...90% r.H.) at $+25\text{ }^\circ\text{C}$ , otherwise $\pm 2.0\%$
Temperature deviation:	typically $\pm 0.2\text{ K}$ at $+25\text{ }^\circ\text{C}$
Zero point offset:	$\pm 10\%$ r.H. (humidity); $\pm 5\text{ }^\circ\text{C}$ (temperature)
Ambient temperature:	$-30...+70\text{ }^\circ\text{C}$
Medium:	clean air and non-aggressive, non-combustible gases
Bus protocol:	Modbus (RTU mode), address range 0...247 selectable
Signal filtering:	4 s / 32 s
Housing:	plastic, UV-resistant, material polyamide, 30% glass-globe reinforced, with quick-locking screws (slotted / Phillips head combination), colour traffic white (similar to RAL 9016), housing cover for display is transparent!
Housing dimensions:	108 x 78.5 x 43.3 mm (Tyr 3 without display) 108 x 78.5 x 45.8 mm (Tyr 3 with display)
Cable connection:	<b>cable gland</b> , plastic (2x M20 x 1.5; with strain relief, exchangeable, inner diameter 8 - 13 mm) or <b>M12 connector</b> according to DIN EN 61076-2-101 (optional on request)
Protective tube:	<b>PLEUROFORM™</b> , material polyamide (PA6), with torsion protection, $\varnothing$ 20 mm, NL = 235 mm, $v_{\text{max}} = 30\text{ m/s}$ (air) (on request, optional <b>stainless steel V2A</b> (1.4301), $\varnothing$ 16 mm)
Process connection:	by mounting flange, plastic (included in the scope of delivery)
Long-term stability:	$\pm 1\%$ / year
Electrical connection:	0.2 - 1.5 mm <sup>2</sup> , using push-in terminals
Permissible air humidity:	< 95% r.H., non-precipitating air
Protection class:	III (according to EN 60 730)
Protection type:	<b>IP 65</b> (according to EN 60 529)
Standards:	CE conformity, electromagnetic compatibility according to EN 61326, according to EMC Directive 2014 / 30 / EU
Optional:	<b>Display with illumination</b> , three-line, programmable, cutout approx. 51 x 29 mm (W x H), for displaying the actual humidity and actual temperature (cyclic) or a selectable parameter (static) or an individually programmable display value
<b>ACCESSORIES</b>	see table

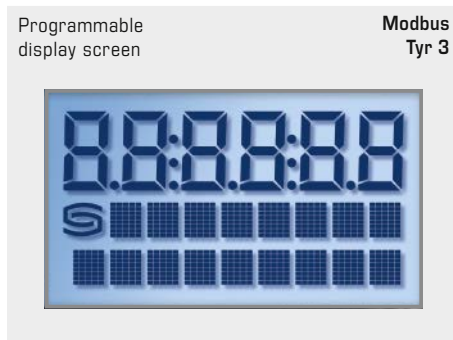
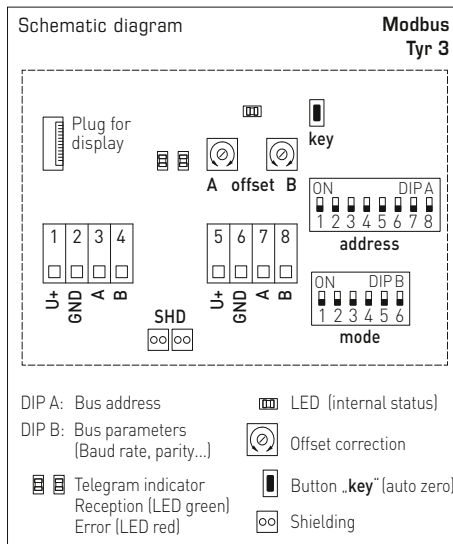





S+S REGELTECHNIK

# HYGRASGARD® KFTF-Modbus-T3 HYGRASGARD® KFTF-20-Modbus-T3

Duct humidity- and temperature sensors ( $\pm 1.8\%$  /  $\pm 2.0\%$ ), incl. mounting flange, for mixture ratio, relative / absolute humidity, dew point, enthalpy and temperature, calibratable, with Modbus connection

Dimensional drawing

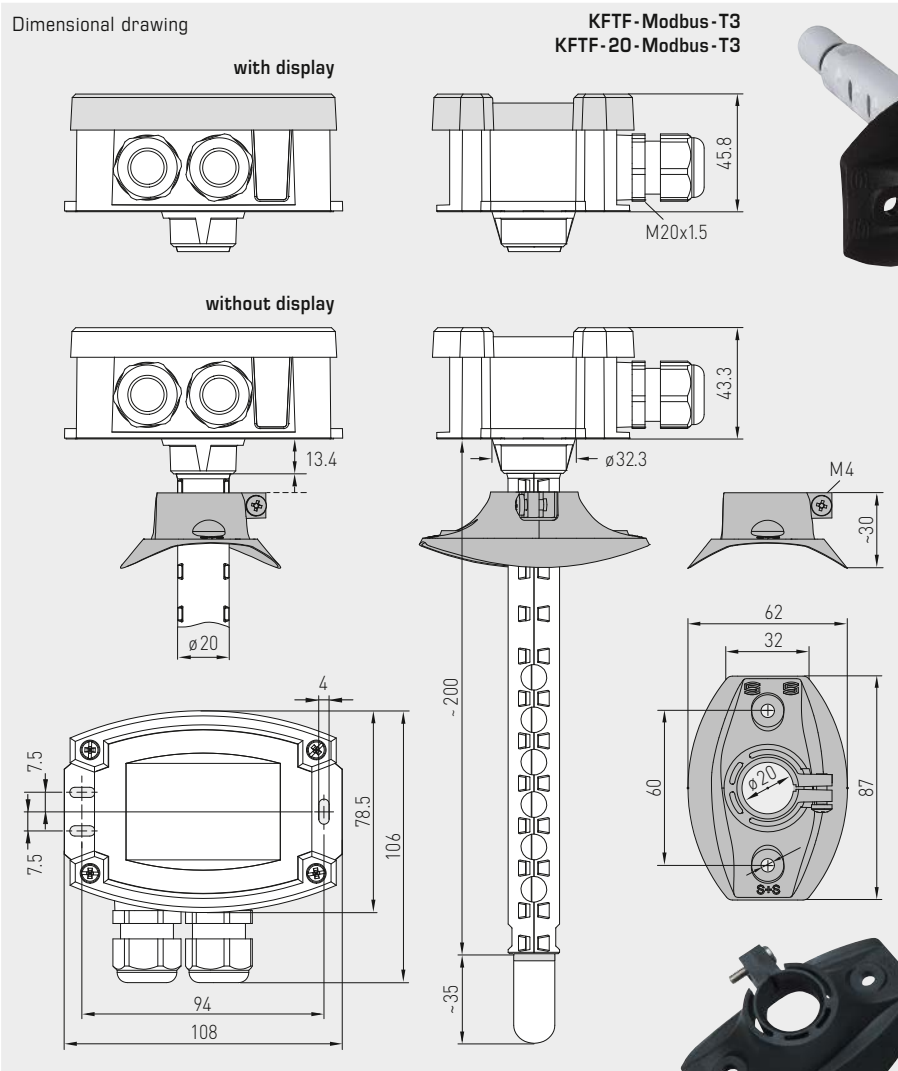

KFTF-Modbus-T3 ( $\pm 2,0\%$ )  
KFTF-20-Modbus-T3 ( $\pm 1,8\%$ )  
with display



**SF-K**  
Plastic sinter filter (standard)



**SF-M**  
Metal sinter filter (optional)



**stainless steel protective tube** (optional on request)

**MFT-20-K**  
Mounting flange, plastic



**HYGRASGARD® KFTF-Modbus-T3** Duct humidity- and temperature sensors ( $\pm 2.0\%$ )  
**HYGRASGARD® KFTF-20-Modbus-T3** Duct humidity- and temperature sensors ( $\pm 1.8\%$ )

Type / WG01	Measuring Range / Readout	Temperature	Output	Display	Item No.	Price
<b>KFTF-Modbus-T3</b>	Humidity (switchable)				<b>(<math>\pm 2,0\%</math>)</b>	
KFTF-Modbus-T3	0 ... 100% r. H. (default) 0 ... 80 g / kg (MV) 0 ... 80 g / m <sup>3</sup> (a.F.) 0 ... 85 kJ / kg (ENT.) -20 ... +80 °C (TP)	-35 ... +80 °C	Modbus		1201-32C6-1000-029	<b>199,18 €</b>
KFTF-Modbus-T3 LCD	(5x as above)	(1x as above)	Modbus	■	1201-32C6-1400-029	<b>251,56 €</b>
<b>KFTF-20-Modbus-T3</b>					<b>(<math>\pm 1,8\%</math>)</b>	
KFTF-20-Modbus-T3	(5x as above)	(1x as above)	Modbus		1201-32C6-1000-030	<b>260,37 €</b>
KFTF-20-Modbus-T3 LCD	(5x as above)	(1x as above)	Modbus	■	1201-32C6-1400-030	<b>392,27 €</b>
Optional:	Cable connection with <b>M12 connector</b> according to DIN EN 61076-2-101					on request

**ACCESSORIES**

<b>KA2-Modbus</b>	Communication adapter (USB/RS485) for system connection	1906-1200-0000-100	<b>203,80 €</b>
<b>LA-Modbus</b>	Line termination device (with terminating resistor) as an active bus termination	1906-1300-0000-100	<b>76,01 €</b>
<b>SF-M</b>	Metal sinter filter, $\varnothing$ 16 mm, L = 32 mm, exchangeable, stainless steel V4A (1.4404)	7000-0050-2200-100	<b>40,31 €</b>
<b>MFT-20-K</b>	Mounting flange, plastic (included in the scope of delivery)		

For further information, see last chapter Accessories!

# HYGRASGARD® RPFTF - Modbus-T3

## HYGRASGARD® RPFTF - 20 - Modbus-T3



S+S REGELTECHNIK

Pendulum room humidity and temperature sensors ( $\pm 1.8\%$  /  $\pm 2.0\%$ ),  
for mixture ratio, relative/absolute humidity, dew point, enthalpy  
and temperature, calibratable, with Modbus connection

Calibratable room pendulum humidity and temperature sensor **HYGRASGARD® RPFTF-Modbus-T3** ( $\pm 2.0\%$ ) or **RPFTF-20-Modbus-T3** ( $\pm 1.8\%$ ), with Modbus connection, in an impact-resistant plastic housing with quick-locking screws, optionally with/without display, cable sensor with a stainless steel pendulum and a plastic sinter filter (exchangeable).

The sensor is used to detect various parameters in humidity measurement. It measures the relative humidity (0...100% r.H.) and the temperature ( $-35...+80\text{ }^\circ\text{C}$ ) of the ambient air. These measurands are used to internally calculate the following parameters that can be retrieved via Modbus: relative humidity [% r.H.], absolute humidity [ $\text{g}/\text{m}^3$ ], mixture ratio [ $\text{g}/\text{kg}$ ], dew point temperature [ $^\circ\text{C}$ ], enthalpy [ $\text{kJ}/\text{kg}$ ] (ignoring atmospheric air pressure) and ambient temperature [ $^\circ\text{C}$ ]. A long-term stable, digital sensor guarantees exact measurement results.

The pendulum sensor is applied in a non-aggressive, dust-free environment and is suitable for installation in ceilings, ducts and devices. It is used in the refrigeration, air conditioning and clean room technology, engineering rooms, hotels and conference facilities.

**Innovative Modbus sensor** with galvanically separated RS485-Modbus-interface, selectable bus termination resistance, DIP switch for setting the bus parameters and bus address in current-free state, LEDs for telegram status display, two separate push-in terminals and large three-line display (illuminated; with customised programming in the 7-segment and dot-matrix range). The sensor is factory-calibrated; an environmental precision adjustment by an expert is possible.

**RPFTF-Modbus-T3** ( $\pm 2,0\%$ )  
**RPFTF-20-Modbus-T3** ( $\pm 1,8\%$ )



Device version  
with **M12 connector**  
(optional on request)



### TECHNICAL DATA

Voltage supply:	24 V AC ( $\pm 20\%$ ) and 15...36 V DC
Power consumption:	< 1.2 W / 24 V DC; < 1.8 VA / 24 V AC
Data points:	Temperature [ $^\circ\text{C}$ ], relative humidity [% r.h.], dew point [ $^\circ\text{C}$ ], absolute humidity [ $\text{g}/\text{m}^3$ ], mixture ratio [ $\text{g}/\text{kg}$ ], enthalpy [ $\text{kJ}/\text{kg}$ ]
Sensors:	<b>digital humidity sensor with integrated temperature sensor</b> , low hysteresis, high long-term stability
Sensor protection:	<b>plastic sinter filter</b> , $\varnothing$ 16 mm, L = 35 mm, exchangeable (optional <b>metal sinter filter</b> , $\varnothing$ 16 mm, L = 32 mm)
Measuring range:	0...100% r.H. (humidity) $-35...+80\text{ }^\circ\text{C}$ (temperature)
Deviation, humidity:	<b>RPFTF-Modbus:</b> typically $\pm 2.0\%$ (20...80% r.h.) at $+25\text{ }^\circ\text{C}$ , otherwise $\pm 3.0\%$ <b>RPFTF-20-Modbus:</b> typically $\pm 1.8\%$ (10...90% r.h.) at $+25\text{ }^\circ\text{C}$ , otherwise $\pm 2.0\%$
Temperature deviation:	typically $\pm 0.2\text{ K}$ at $+25\text{ }^\circ\text{C}$
Zero point offset:	$\pm 10\%$ r.h. (humidity); $\pm 5\text{ }^\circ\text{C}$ (temperature)
Ambient temperature:	$-30...+70\text{ }^\circ\text{C}$
Medium:	clean air and non-aggressive, non-combustible gases
Bus protocol:	Modbus (RTU mode), address range 0...247 selectable
Signal filtering:	4 s / 32 s
Housing:	plastic, UV-resistant, material polyamide, 30% glass-globe reinforced, with quick-locking screws (slotted / Phillips head combination), colour traffic white (similar to RAL 9016), housing cover for display is transparent!
Housing dimensions:	108 x 78.5 x 43.3 mm (Tyr 3 without display) 108 x 78.5 x 45.8 mm (Tyr 3 with display)
Cable connection:	<b>cable gland</b> , plastic (2x M20 x 1.5; with strain relief, exchangeable, inner diameter 8 - 13 mm) or <b>M12 connector</b> according to DIN EN 61076-2-101 (optional on request)
Connection cable:	PVC, LiYY, 6 x 0.14 mm <sup>2</sup> , cable length (KL) = approx. 2 m (other lengths optional)
Protective tube:	<b>stainless steel V2A</b> (1.4301), $\varnothing$ 16 mm, NL = 142 mm
Electrical connection:	0.2 - 1.5 mm <sup>2</sup> , using push-in terminals
Permissible air humidity:	< 95% r.H., non-precipitating air
Protection class:	III (according to EN 60 730)
Protection type:	<b>IP 65</b> (according to EN 60 529)
Standards:	CE conformity, electromagnetic compatibility according to EN 61326, according to EMC Directive 2014 / 30 / EU
Optional:	<b>Display with illumination</b> , three-line, programmable, cutout approx. 51 x 29 mm (W x H), for displaying the actual humidity and actual temperature (cyclic) or a selectable parameter (static) or an individually programmable display value
<b>ACCESSORIES</b>	see table

### Schematic diagram

Modbus  
Tyr 3

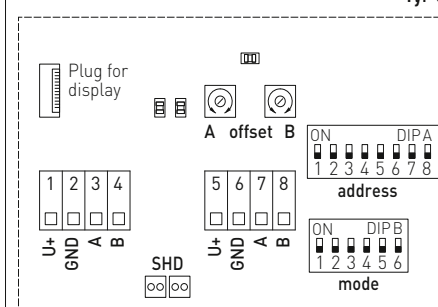

- DIP A: Bus address
- DIP B: Bus parameters (Baud rate, parity...)
- Telegram indicator Reception (LED green) Error (LED red)
- LED (internal status)
- Offset correction
- Shielding

### Programmable display screen

Modbus  
Tyr 3





S+S REGELTECHNIK

# HYGRASGARD® RPFTF-Modbus-T3 HYGRASGARD® RPFTF-20-Modbus-T3

Pendulum room humidity and temperature sensors ( $\pm 1.8\%$  /  $\pm 2.0\%$ ),  
for mixture ratio, relative/absolute humidity, dew point, enthalpy  
and temperature, calibratable, with Modbus connection

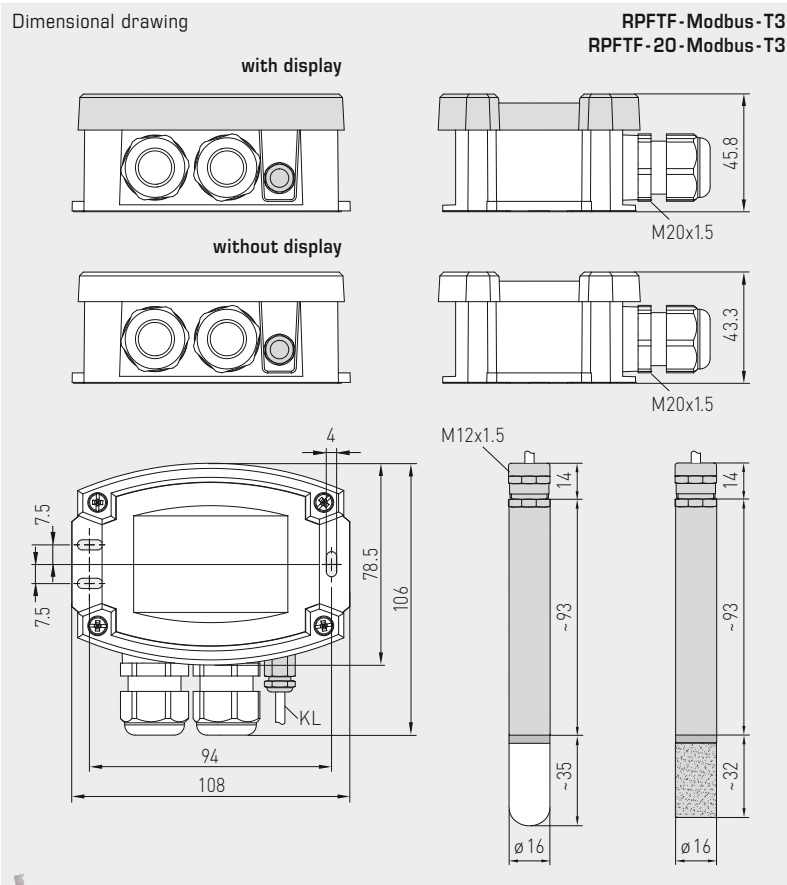

RPFTF-Modbus-T3 ( $\pm 2,0\%$ )  
RPFTF-20-Modbus-T3 ( $\pm 1,8\%$ )  
with display



**MF-16-K**  
Mounting flange,  
plastic (optional)



**SF-K**  
plastic sinter filter  
(standard)



**SF-M**  
metal sinter filter  
(optional)



**HYGRASGARD® RPFTF-Modbus-T3** Pendulum room humidity and temperature sensors ( $\pm 2.0\%$ )  
**HYGRASGARD® RPFTF-20-Modbus-T3** Pendulum room humidity and temperature sensors ( $\pm 1.8\%$ )

Type / WG01	Measuring Range / Readout Humidity (switchable)	Temperature	Output	Display	Item No.	Price
<b>RPFTF-Modbus-T3</b>					<b>(<math>\pm 2,0\%</math>)</b>	
RPFTF-Modbus-T3	0 ... 100% r. H. (default) 0 ... 80 g / kg (MV) 0 ... 80 g / m <sup>3</sup> (a.F.) 0 ... 85 kJ / kg (ENT.) -20 ... +80 °C (TP)	-35 ... +80 °C	Modbus		1201-6246-1000-000	<b>282,21 €</b>
RPFTF-Modbus-T3 LCD	(5 x as above)	(1 x as above)	Modbus	■	1201-6246-1400-000	<b>334,31 €</b>
<b>RPFTF-20-Modbus-T3</b>					<b>(<math>\pm 1,8\%</math>)</b>	
RPFTF-20-Modbus-T3	(5 x as above)	(1 x as above)	Modbus		1201-6246-1000-001	<b>338,55 €</b>
RPFTF-20-Modbus-T3 LCD	(5 x as above)	(1 x as above)	Modbus	■	1201-6246-1400-001	<b>391,18 €</b>
Extra charge:	per running metre of connecting lead (PVC) Cable connection with <b>M12 connector</b> according to DIN EN 61076-2-101				on request on request	
<b>ACCESSORIES</b>						
<b>KA2-Modbus</b>	<b>Communication adapter</b> (USB/RS485) for system connection				1906-1200-0000-100	<b>203,80 €</b>
<b>LA-Modbus</b>	<b>Line termination device</b> (with terminating resistor) as an active bus termination				1906-1300-0000-100	<b>76,01 €</b>
<b>SF-M</b>	<b>Metal sinter filter</b> , $\varnothing$ 16 mm, L = 32 mm, exchangeable, stainless steel V4A (1.4404)				7000-0050-2200-100	<b>40,31 €</b>
<b>MF-16-K</b>	<b>Mounting flange</b> made of plastic (optional)				7100-0030-0000-000	<b>9,10 €</b>

Showcase humidity and temperature sensor ( $\pm 2.0\%$ ),  
for mixture ratio, relative/absolute humidity, dew point, enthalpy  
and temperature, calibratable, with Modbus connection

Calibratable display cases humidity and temperature sensor **HYGRASGARD® VFTF-Modbus-T3** with Modbus connection, in an impact-resistant plastic housing with quick-locking screws, optionally with /without display, cable sensor with a flat stainless steel probe (pluggable).

The sensor is used to detect various parameters in humidity measurement. It measures the relative humidity (0...100% r.H.) and the temperature ( $-35...+80\text{ }^\circ\text{C}$ ) of the ambient air. These measurands are used to internally calculate the following parameters that can be retrieved via Modbus: relative humidity [% r.H.], absolute humidity [ $\text{g}/\text{m}^3$ ], mixture ratio [ $\text{g}/\text{kg}$ ], dew point temperature [ $^\circ\text{C}$ ], enthalpy [ $\text{kJ}/\text{kg}$ ] (ignoring atmospheric air pressure) and ambient temperature [ $^\circ\text{C}$ ]. A long-term stable, digital sensor guarantees exact measurement results.

The display cases sensor is applied in a non-aggressive, dust-free environment and is specially suitable for installation in ceilings, walls, display cases or showcases. It is used in museums, galleries, cinemas, lecture halls or laboratories.

**Innovative Modbus sensor** with galvanically separated RS485-Modbus-interface, selectable bus termination resistance, DIP switch for setting the bus parameters and bus address in current-free state, LEDs for telegram status display, two separate push-in terminals and large three-line display (illuminated; with customised programming in the 7-segment and dot-matrix range). The sensor is factory-calibrated; an environmental precision adjustment by an expert is possible.

## TECHNICAL DATA

Voltage supply:	24 V AC ( $\pm 20\%$ ) and 15...36 V DC
Power consumption:	< 1.2 W / 24 V DC; < 1.8 VA / 24 V AC
Data points:	Temperature [ $^\circ\text{C}$ ], relative humidity [% r.H.], dew point [ $^\circ\text{C}$ ], absolute humidity [ $\text{g}/\text{m}^3$ ], mixture ratio [ $\text{g}/\text{kg}$ ], enthalpy [ $\text{kJ}/\text{kg}$ ]
Sensor:	<b>digital humidity sensor with integrated temperature sensor</b> , low hysteresis, high long-term stability
Measuring Range:	0...100% r.H. (humidity) $-35...+80\text{ }^\circ\text{C}$ (temperature)
Deviation in humidity:	typically $\pm 2.0\%$ (20...80% r.H.) at $+25\text{ }^\circ\text{C}$ , otherwise $\pm 3.0\%$
Deviation in temperature:	typically $\pm 0.2\text{ K}$ at $+25\text{ }^\circ\text{C}$
Zero point offset:	$\pm 10\%$ r.H. (humidity); $\pm 5\text{ }^\circ\text{C}$ (temperature)
Ambient temperature:	$-30...+70\text{ }^\circ\text{C}$
Medium:	clean air and non-aggressive, non-combustible gases
Bus protocol:	Modbus (RTU mode), address range 0...247 selectable
Signal filtering:	4 s / 32 s
Housing:	plastic, UV-resistant, material polyamide, 30% glass-globe reinforced, with quick-locking screws (slotted / Phillips head combination), colour traffic white (similar to RAL 9016), housing cover for display is transparent!
Housing dimensions:	108 x 78.5 x 43.3 mm (Tyr 3 without display) 108 x 78.5 x 45.8 mm (Tyr 3 with display)
Cable connection:	<b>cable gland</b> , plastic (2x M20 x 1.5; with strain relief, exchangeable, inner diameter 8 - 13 mm) or <b>M12 connector</b> according to DIN EN 61076-2-101 (optional on request)
Connection cable:	PVC, LiYY, 4 x 0.14 mm <sup>2</sup> , cable length (KL) = approx. 2 m (other lengths optional)
Sensor protection:	<b>probe</b> made of stainless steel, V4A (1.4571), <b>pluggable</b> ; sensor head $\varnothing = 17\text{ mm}$ , H = approx. 2.5 mm; protective sleeve $\varnothing = 10\text{ mm}$ , NL = approx. 25 mm, M10 x 1.0; with plastic plug connector $\varnothing = \text{approx. } 11\text{ mm}$ , NL = approx. 25 mm
Mounting (sensor):	cut-out $\varnothing = 11 - 15\text{ mm}$ , inserted length (EL) = approx. 50 mm, lock nut for fixing is included in the scope of delivery.
Electrical connection:	0.2 - 1.5 mm <sup>2</sup> , using push-in terminals
Permissible air humidity:	< 95% r.H., non-precipitating air
Protection class:	III (according to EN 60 730)
Protection type:	<b>IP 65</b> (according to EN 60 529)
Standards:	CE conformity, electromagnetic compatibility according to EN 61326, according to EMC Directive 2014 / 30 / EU
Optional:	<b>Display with illumination</b> , three-line, programmable, cutout approx. 51 x 29 mm (W x H), for displaying the actual humidity and actual temperature (cyclic) or a selectable parameter (static) or an individually programmable display value
<b>ACCESSORIES</b>	see table

VFTF-Modbus-T3



Device version with **M12 connector** (optional on request)



Schematic diagram

Modbus Tyr 3

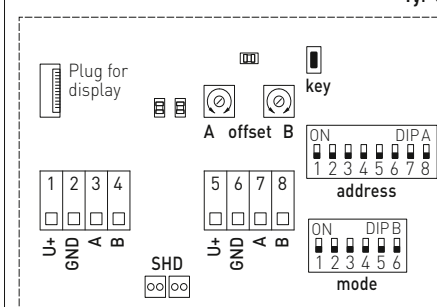

- DIP A: Bus address
- DIP B: Bus parameters (Baud rate, parity...)
- Telegram indicator Reception (LED green) Error (LED red)
- LED (internal status)
- Offset correction
- Button „key“ (auto zero)
- Shielding

Programmable display screen

Modbus Tyr 3







Showcase humidity and temperature sensor ( $\pm 2.0\%$ ),  
for mixture ratio, relative/absolute humidity, dew point, enthalpy  
and temperature, calibratable, with Modbus connection

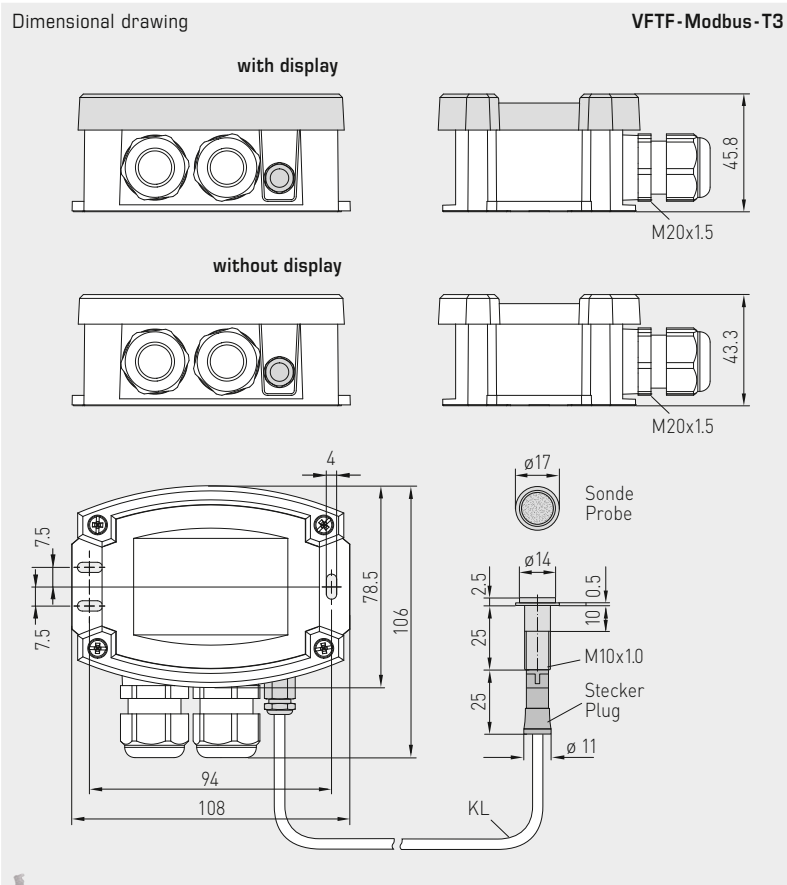

VFTF-Modbus-T3  
with display



Probe  
made of stainless steel,  
pluggable

HYGRASGARD® VFTF-Modbus-T3 Showcase humidity and temperature sensor ( $\pm 2.0\%$ ), Premium

Type/WG01	Measuring Range/Readout Humidity (switchable)	Temperature	Output	Display	Item no.	Price
<b>VFTF-Modbus-T3</b>						
VFTF-Modbus-T3	0...100% r. H. (default) 0...80 g/kg (MV) 0...80 g/m <sup>3</sup> (a.F.) 0...85 kJ/kg (ENT.) -20...+80 °C (TP)	-35...+80 °C	Modbus		1201-6256-1000-000	485,81 €
VFTF-Modbus-T3 LCD	(5 x as above)	(1 x as above)	Modbus	■	1201-6256-1400-000	541,36 €
Extra charge:	cable length (KL = approx. 2 m), other lengths optional				on request	
	Cable connection with M12 connector according to DIN EN 61076-2-101				on request	

ACCESSORIES

KA2-Modbus	Communication adapter (with USB and RS485 interface) for system connection (incl. quick-start software)				1906-1200-0000-100	203,80 €
LA-Modbus	Line termination device (with terminating resistor) as an active bus termination of RS485 networks				1906-1300-0000-100	76,01 €

Dew point control switches, incl. strap / with detached sensor head ( $\pm 2.0\%$ ), for mixture ratio, relative / absolute humidity, dew point, enthalpy and temperature, calibratable, with Modbus connection

## Patented quality product

(pro-dynamic cross convection patent no. DE 10 2012 015 726.6)

Calibratable dew point control switch **HYGRASGARD® TW-Modbus-T3** (compact variant incl. strap) or **TW-Modbus-external** (detached variant), with Modbus connection, in an impact-resistant plastic housing with quick-locking screws, optionally with /without display. It reliably detects the formation of dew due to its patented measuring method, the **pro-dynamic cross-convection** (no conductivity measurement).

The sensor is used to detect various parameters in humidity measurement. It measures the relative humidity (0...100% r.H.) and the temperature ( $-35...+80\text{ }^\circ\text{C}$ ) of the ambient air. These measurands are used to internally calculate the following parameters that can be retrieved via Modbus: relative humidity [% r.H.], absolute humidity [ $\text{g}/\text{m}^3$ ], mixture ratio [ $\text{g}/\text{kg}$ ], dew point temperature [ $^\circ\text{C}$ ], enthalpy [ $\text{kJ}/\text{kg}$ ] (ignoring atmospheric air pressure) and ambient temperature [ $^\circ\text{C}$ ]. A long-term stable, digital sensor guarantees exact measurement results.

The surface-contact sensor is applied in a non-aggressive, dust-free environment and is suitable for installation in ceilings, ducts and devices. It is used in the refrigeration, air conditioning and clean room technology, engineering rooms, hotels and conference facilities.

**Innovative Modbus sensor** with galvanically separated RS485-Modbus-interface, selectable bus termination resistance, DIP switch for setting the bus parameters and bus address in current-free state, LEDs for telegram status display, two separate push-in terminals and large three-line display (illuminated; with customised programming in the 7-segment and dot-matrix range). The sensor is factory-calibrated; an environmental precision adjustment by an expert is possible.

## TECHNICAL DATA

Voltage supply:	24 V AC ( $\pm 20\%$ ); 15...36 V DC
Power consumption:	< 1.2 W / 24 V DC; < 1.8 VA / 24 V AC
Data points:	Temperature [ $^\circ\text{C}$ ], relative humidity [% r.H.], dew point [ $^\circ\text{C}$ ], absolute humidity [ $\text{g}/\text{m}^3$ ], mixture ratio [ $\text{g}/\text{kg}$ ], enthalpy [ $\text{kJ}/\text{kg}$ ]
Sensor:	<b>Digital humidity sensor with integrated temperature sensor</b> , low hysteresis, high long-term stability
Sensor protection:	membrane filter
Measuring range:	0...100% r.H. (humidity) $-35...+80\text{ }^\circ\text{C}$ (temperature)
Deviation, humidity:	typically $\pm 2.0\%$ (20...80% r.H.) at $+25\text{ }^\circ\text{C}$ , otherwise $\pm 3.0\%$
Deviation, temperature:	typically $\pm 0.2\text{ K}$ at $+25\text{ }^\circ\text{C}$
Zero point offset:	$\pm 10\%$ r.H. (humidity); $\pm 5\text{ }^\circ\text{C}$ (temperature)
Ambient temperature:	$-30...+70\text{ }^\circ\text{C}$
Medium:	clean air and non-aggressive, non-combustible gases
Bus protocol:	Modbus (RTU mode), address range 0...247 selectable
Signal filtering:	4 s / 32 s
Housing:	plastic, UV-resistant, material polyamide, 30% glass-globe reinforced, with quick-locking screws (slotted / Phillips head combination), colour traffic white (similar to RAL 9016), housing cover for display is transparent!
Housing dimensions:	108 x 78.5 x 43.3 mm (Tyr 3 without display) 108 x 78.5 x 45.8 mm (Tyr 3 with display)
Cable connection:	<b>cable gland</b> , plastic (2x M20 x 1.5; with strain relief, exchangeable, inner diameter 8 - 13 mm) or <b>M12 connector</b> according to DIN EN 61076-2-101 (optional on request)
Process connection:	endless strap with metal tightener, 300 mm, for pipes up to 3"
Installation:	<b>TW-Modbus</b> with strap for direct mounting on pipes or for direct mounting on flat surfaces (e.g. walls, ceilings) <b>TW-Modbus-external</b> with detached sensor head (cable length KL = 1.5 m) for mounting on pipes
Electrical connection:	0.2 - 1.5 mm <sup>2</sup> , using push-in terminals
Permissible air humidity:	< 95% r.H., non-precipitating air
Protection class:	III (according to EN 60 730)
Protection type:	<b>IP 65</b> (according to EN 60 529)
Standards:	CE conformity, electromagnetic compatibility according to EN 61326, according to EMC Directive 2014 / 30 / EU
Optional:	<b>Display with illumination</b> , three-line, programmable, cutout approx. 51 x 29 mm (W x H), for displaying the actual humidity and actual temperature (cyclic) or a selectable parameter (static) or an individually programmable display value
<b>ACCESSORIES</b>	see table

**TW-Modbus-T3**  
(compact variant)



Device version with **M12 connector** (optional on request)



**TW-extern-Modbus-T3**  
(detached variant)





Dew point control switches, incl. strap /with detached sensor head ( $\pm 2.0\%$ ), for mixture ratio, relative /absolute humidity, dew point, enthalpy and temperature, calibratable, with Modbus connection

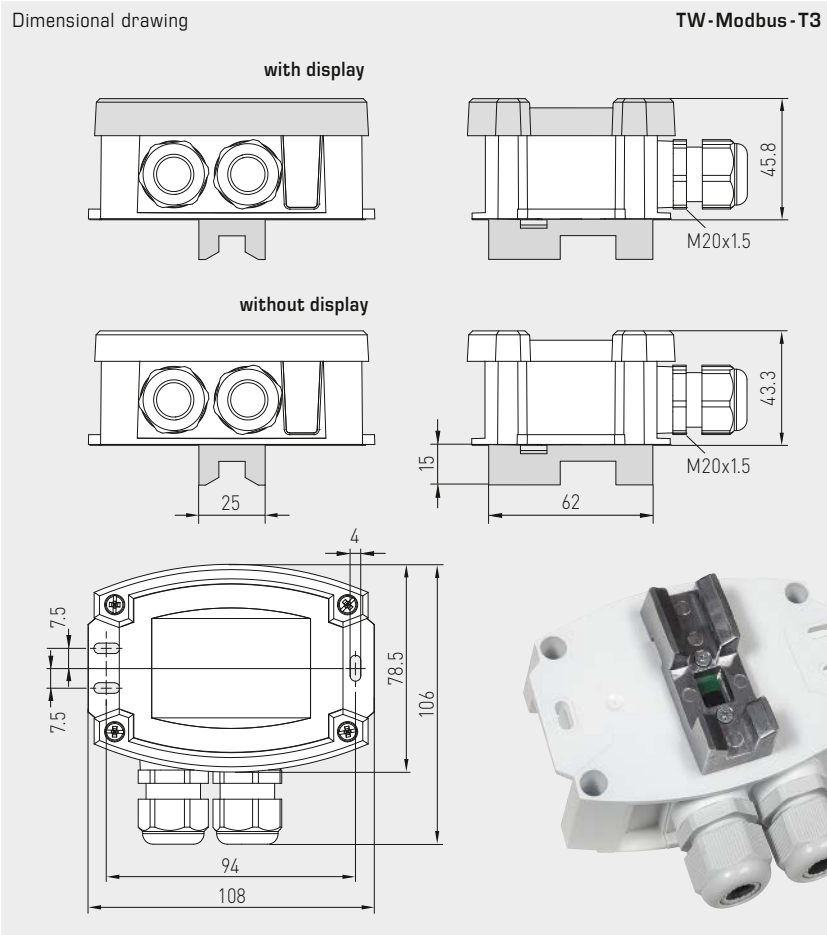

**TW-Modbus-T3**  
(compact variant)  
with display

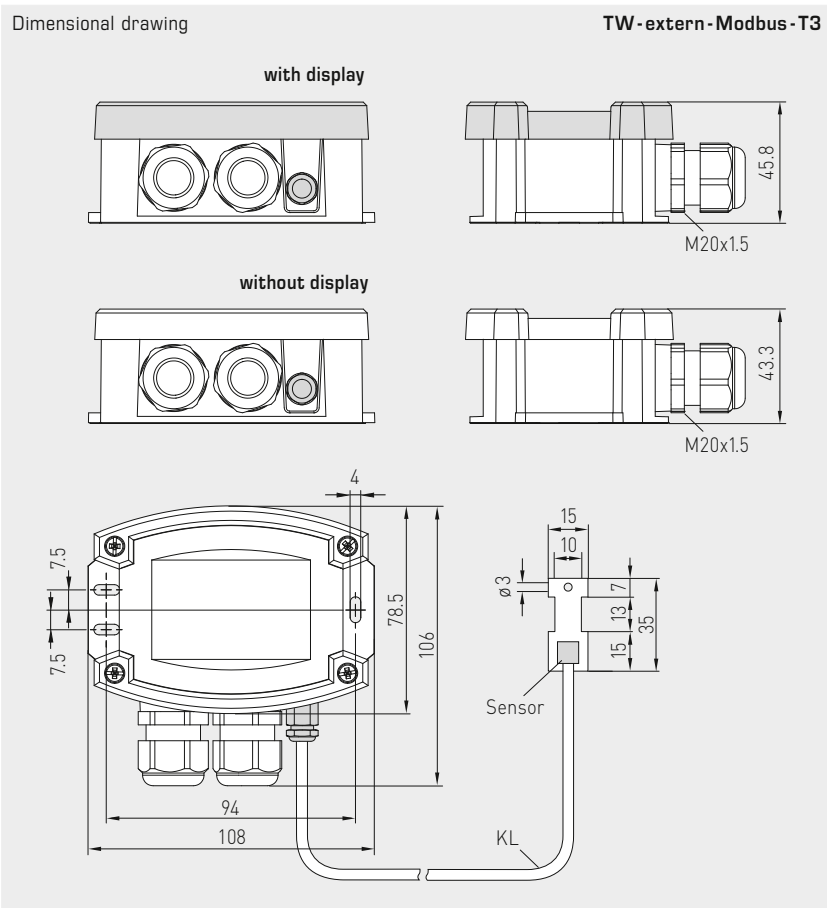

**TW-extern-Modbus-T3**  
(detached variant)  
with display



Dew point control switches, incl. strap/with detached sensor head ( $\pm 2.0\%$ ), for mixture ratio, relative/absolute humidity, dew point, enthalpy and temperature, calibratable, with Modbus connection

Display screen (cyclic) standard



Display screen (static) alternative output variables

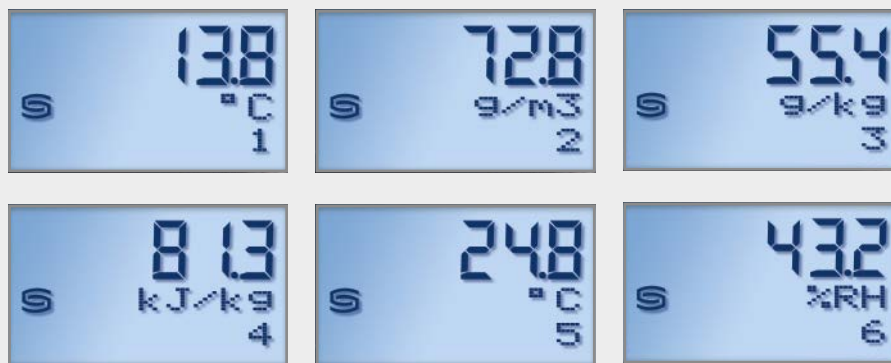

HYGRASGARD® Modbus-T3

By default, the display alternates between the **actual temperature** and the **actual humidity** (relative humidity). For improved legibility, backlighting is provided.

The Modbus interface can be used to program an **alternative output variable** instead of the standard display. In this case, the first line indicates the value while the second line indicates the corresponding unit **statically**. The index in the third line indicates the display type:

- Index 1** = dew point [°C]
- Index 2** = absolute humidity [g/m³]
- Index 3** = mixture ratio [g/kg]
- Index 4** = enthalpy [kJ/kg]
- Index 5** = temperature [°C]
- Index 6** = relative humidity [% r.H.]

Programmable display screen

Modbus Tyr 3



The Modbus interface allows the display to be **individually** configured both in the 7-segment area and in the dot-matrix area.

## TW - Modbus - T3 pro-dynamic cross convection



**PATENTED**



Schematic diagram

Modbus Tyr 3

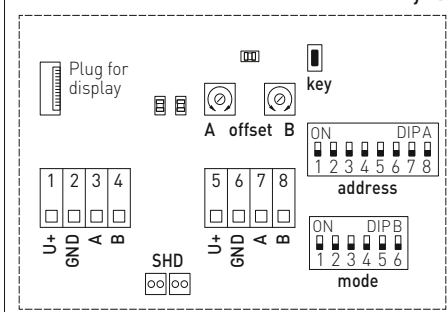

- DIP A: Bus address
- DIP B: Bus parameters (Baud rate, parity...)
- Telegram indicator Reception (LED green) Error (LED red)
- LED (internal status)
- Offset correction
- Button „key“ (auto zero)
- Shielding





Dew point control switches, incl. strap /with detached sensor head ( $\pm 2.0\%$ ),  
for mixture ratio, relative/absolute humidity, dew point, enthalpy  
and temperature, calibratable, with Modbus connection

TW - Modbus - T3  
with display



**HYGRASGARD® TW - Modbus - T3** Dew point control switches, incl. strap ( $\pm 2.0\%$ )  
**HYGRASGARD® TW - external - Modbus - T3** Dew point control switches, with detached sensor head ( $\pm 2.0\%$ )

Type / WG01	Measuring Range / Readout Humidity (switchable)	Temperature	Output	Display	Item No.	Price
<b>TW - Modbus - T3</b>						
TW-Modbus-T3	0 ... 100% r. H. (default) 0 ... 80 g / kg (MR) 0 ... 80 g / m <sup>3</sup> (A.H.) 0 ... 85 kJ / kg (ENT.) -20 ... +80 °C (DP)	-35 ... +80 °C	Modbus		1201-1281-3001-020	<b>181,39 €</b>
TW-Modbus-T3 LCD	(5x as above)	(1x as above)	Modbus	■	1201-1281-3401-020	<b>233,57 €</b>
<b>TW - external - Modbus - T3</b>						
TW-extern-Modbus-T3	0 ... 100% r. H. (default) 0 ... 80 g / kg (MR) 0 ... 80 g / m <sup>3</sup> (A.H.) 0 ... 85 kJ / kg (ENT.) -20 ... +80 °C (DP)	-35 ... +80 °C	Modbus		1201-1281-3001-030	<b>198,46 €</b>
TW-extern-Modbus-T3 LCD	(5x as above)	(1x as above)	Modbus	■	1201-1281-3401-030	<b>237,17 €</b>
Optional:	Cable connection with <b>M12 connector</b> according to DIN EN 61076-2-101					on request

<b>ACCESSORIES</b>						
<b>KA2-Modbus</b>	<b>Communication adapter</b> (with USB and RS485 interface) for system connection (incl. quick-start software)				1906-1200-0000-100	<b>203,80 €</b>
<b>LA-Modbus</b>	<b>Line termination device</b> (with terminating resistor) as an active bus termination of RS485 networks				1906-1300-0000-100	<b>76,01 €</b>

**Pressure and differential pressure measuring transducers,  
incl. connection set,  
with Modbus connection**

Maintenance-free pressure measuring transducer **PREMASGARD® 232x - Modbus - T3** (Series), with Modbus connection, in an impact-resistant plastic housing with quick-locking screws, optionally with /without display, nozzles for pressure hose (Ø 6 mm), incl. connection set **ASD-06** (2m connecting hose, two pressure port nipples, screws).

The on-wall sensor is used to measure positive, negative or differential pressure in clean air (non-precipitating) or gaseous, non-aggressive, non-combustible media. It is used in the clean room, medical and filter technology, ventilation and air conditioning ducts, spray booths, large-scale catering facilities, for filter monitoring and level measurement or for triggering frequency converters. The piezoresistive measuring element is temperature-compensated and guarantees a high degree of reliability and accuracy.

**Innovative Modbus sensor** with galvanically separated RS485-Modbus-interface, selectable bus termination resistance, DIP switch for setting the bus parameters and bus address in current-free state, LEDs for telegram status display, two separate push-in terminals and large three-line display (illuminated; with customised programming in the 7-segment and dot-matrix range). The sensor is factory-calibrated; an environmental precision adjustment by an expert is possible.

PREMASGARD® 232x - Modbus - T3



**TECHNICAL DATA**

Power supply:	24 V AC (±20%) and 15...36 V DC
Power consumption:	< 1.2 W / 24 V DC; < 1.8 VA / 24 V AC
Type of pressure:	differential pressure
Pressure connection:	with connection nozzles for pressure hose Ø 6 mm
Measuring ranges:	<b>-500... +500 Pa</b> or <b>-7000...+7000 Pa</b> depending on the type of device, see table
Accuracy:	<b>Type 2328</b> (500 Pa): typically ± 3 Pa at +25 °C <b>Type 2327</b> (7000 Pa): typically ±35 Pa at +25 °C compared to the calibrated reference device
Above- / below-pressure:	max. ± 50 kPa
Zero point offset:	± 5 % measuring range
Medium:	clean air and other non-aggressive, non-combustible gases
Media contacting parts:	Brass, Ni, Duroplast, Si, epoxy, RTV, BSG, UV silicone gel
Media temperature:	-20...+50 °C (temperature-compensated 0...+50 °C)
Hysteresis:	0.3% of final value
Linearity:	< ± 1 % of final value
Temperature drift values:	± 0.1 % / °C
Long-term stability:	± 1 % per year
Housing:	plastic, UV-resistant, material polyamide, 30% glass-globe reinforced, with quick-locking screws (slotted / Phillips head combination), colour traffic white (similar to RAL 9016), housing cover for display is transparent!
Housing dimensions:	108 x 78.5 x 43.3 mm (Tyr 3 without display) 108 x 78.5 x 45.8 mm (Tyr 3 with display)
Cable connection:	<b>cable gland</b> , plastic (2x M 20 x 1.5; with strain relief, exchangeable, inner diameter 8 - 13 mm) or <b>M12 connector</b> according to DIN EN 61076-2-101 (optional on request)
Electrical connection:	0.2 - 1.5 mm², using push-in terminals
Permissible air humidity:	< 95 % r. H., non-precipitating air
Protection class:	III (according to EN 60 730)
Protection type:	<b>IP65</b> (according to EN 60 529)
Standards:	CE conformity, electromagnetic compatibility according to EN 61 326, EMC directive 2014 / 30 / EU
Optional:	<b>Display with illumination</b> , three-line, programmable, cut-out approx. 51 x 29 mm (W x H), for displaying the ACTUAL pressure or an individually programmable display value
<b>ACCESSORIES</b>	see table

Device version with **M12 connector** (optional on request)

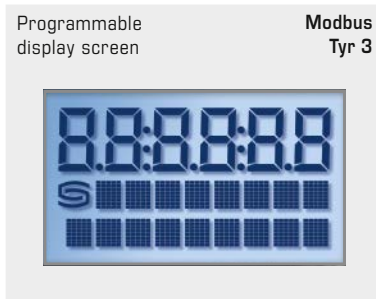

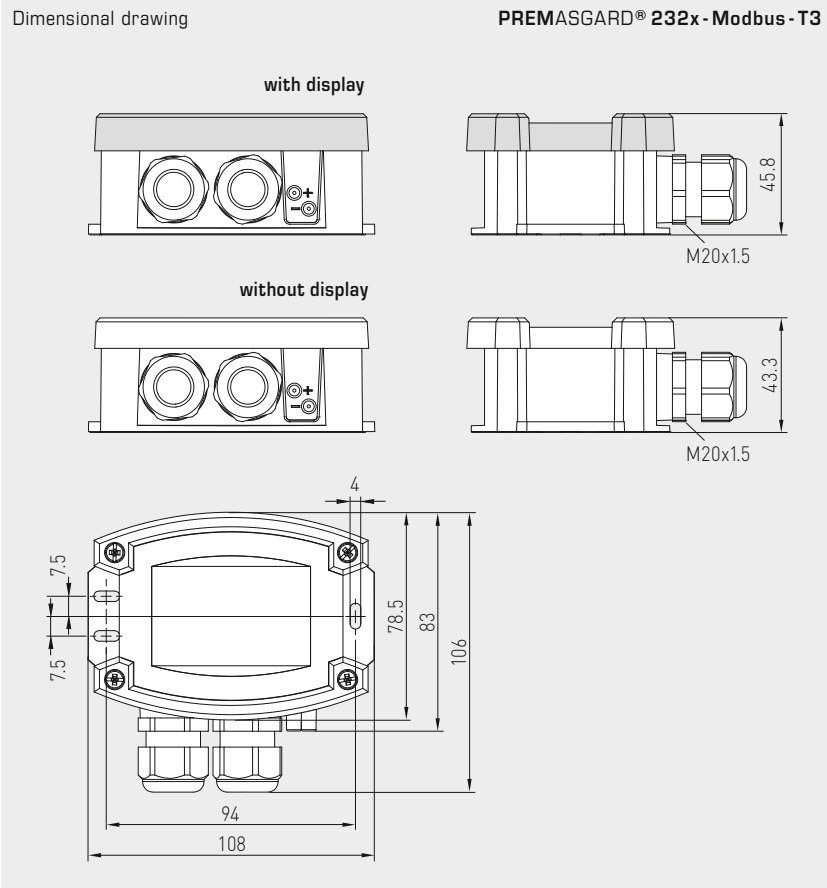

PREMASGARD® 232x - Modbus - T3 with display

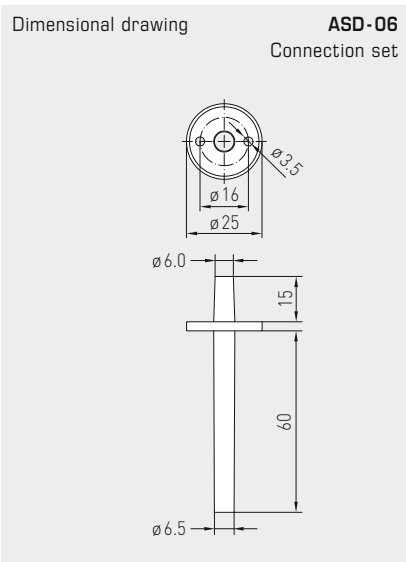

ASD-06 Connection set

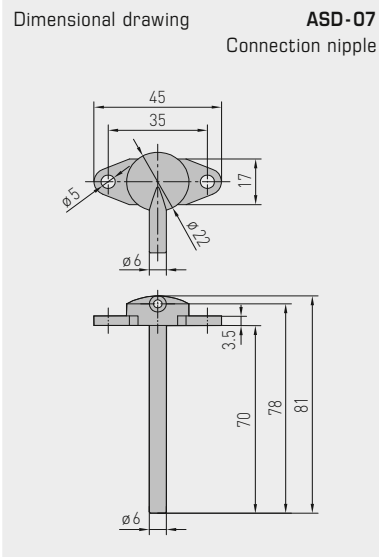

ASD-07 Connection nipple

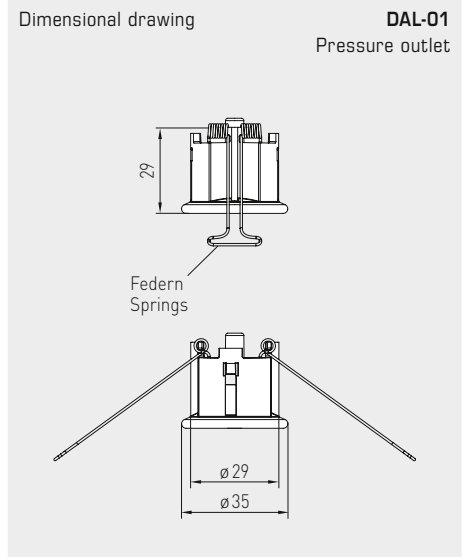

DAL-01 Pressure outlet



Pressure and differential pressure measuring transducers,  
incl. connection set,  
with Modbus connection

### WS-04

Weather and sun protection hood  
(optional)

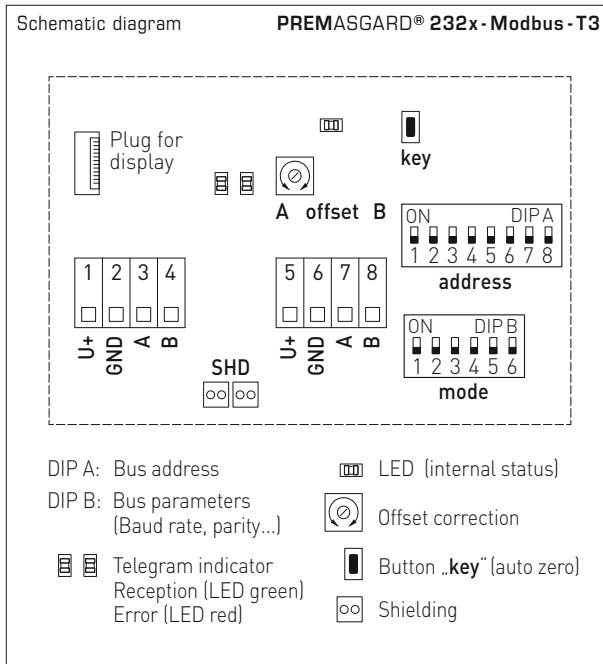

Mounting diagram **PREMASGARD® 232x - Modbus - T3**

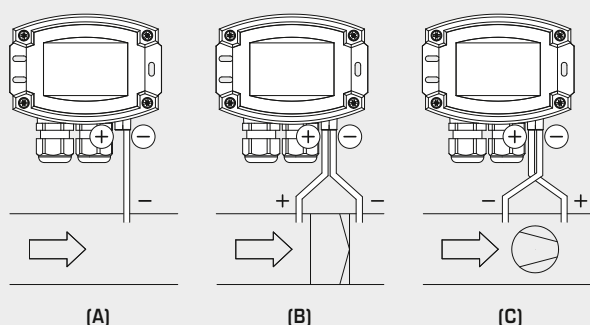

### TYPES OF MONITORING:

- (A) Below-atmospheric pressure:**  
P1 (+) is not connected but open against atmosphere  
P2 (-) connected to inside of duct
- (B) Filter:**  
P1 (+) connected upstream of filter  
P2 (-) connected downstream of filter
- (C) Ventilator:**  
P1 (+) connected downstream of ventilator  
P2 (-) connected upstream of ventilator

Pressure connections at the pressure switch are marked with P1 (+) for higher pressure and P2 (-) for lower pressure.

### Conversion table for pressure values:

Unit =	bar	mbar	Pa	kPa	mWS
1 Pa	0.00001 bar	0.01 mbar	1 Pa	0.001 kPa	0.000101971 mWS
1 kPa	0.01 bar	10 mbar	1000 Pa	1 kPa	0.101971 mWS
1 bar	1 bar	1000 mbar	100000 Pa	100 kPa	10.1971 mWS
1 mbar	0.001 bar	1 mbar	100 Pa	0.1 kPa	0.0101971 mWS
1 mWS	0.0980665 bar	98.0665 mbar	9806.65 Pa	9.80665 kPa	1 mWS





S+S REGELTECHNIK

Pressure and differential pressure measuring transducers,  
incl. connection set,  
with Modbus connection

PREMASGARD® 232x - Modbus - T3  
with display



**PREMASGARD® 232x - Modbus - T3** Pressure and differential pressure measuring transducers

Type / WG01	Measuring Range Pressure range	Output	Display	Item No.	Price
<b>PREMASGARD® 2328 - Modbus - T3</b>	<b>- 500...+ 500 Pa</b>				
PREMASGARD 2328	-500...+ 500 Pa	Modbus		1301-12C4-0910-200	<b>154,11 €</b>
PREMASGARD 2328 LCD	-500...+ 500 Pa	Modbus	■	1301-12C4-4910-200	<b>203,98 €</b>
<b>PREMASGARD® 2327 - Modbus - T3</b>	<b>- 7000...+ 7000 Pa</b>				
PREMASGARD 2327	-7000...+ 7000 Pa	Modbus		1301-12C4-0950-200	<b>154,11 €</b>
PREMASGARD 2327 LCD	-7000...+ 7000 Pa	Modbus	■	1301-12C4-4950-200	<b>203,98 €</b>
Optional:	Cable connection with <b>M12 connector</b> according to DIN EN 61076-2-101			on request	

**ACCESSORIES**

<b>KA2-Modbus</b>	<b>Communication adapter</b> (USB/RS485) for system connection			1906-1200-0000-100	<b>203,80 €</b>
<b>LA-Modbus</b>	<b>Line termination device</b> (with terminating resistor) as an active bus termination			1906-1300-0000-100	<b>76,01 €</b>
<b>ASD-06</b>	<b>Connection set (included in the scope of delivery)</b> , consisting of 2 connection nipples (straight) made of ABS, 2 m PVC hose (soft, UV-resistant) and 4 screws			7100-0060-3000-000	<b>7,28 €</b>
<b>ASD-07</b>	<b>2 connection nipples</b> (at 90 degree angle) made of plastic, ABS			7100-0060-7000-000	<b>7,28 €</b>
<b>DAL-01</b>	<b>Pressure outlet</b> for ceiling or in-wall installation (e.g. in clean rooms)			7300-0060-3000-001	<b>34,07 €</b>
<b>WS-04</b>	<b>Weather and sun protection hood</b> , 130 x 180 x 135 mm, stainless steel V2A (1.4301)			7100-0040-7000-000	<b>35,70 €</b>

For further information, see last chapter Accessories!

**Pressure sensor and measuring transducer for differential pressure and volume flow, incl. connection set, calibratable, with Modbus connection**

Maintenance-free, microprocessor-controlled **PREMASGARD® 714x-Modbus** (series) with Modbus connection, impact-resistant plastic housing, optionally with/without display, with cable gland or M12 connector according to DIN EN 61076-2-101, for measuring the differential pressure (max. -7000...+7000 Pa) in air. Incl. connection kit **ASD-06** (2m connecting hose, two pressure port nipples, screws).

The pressure sensor is applied to measure positive, negative or differential pressure in clean air and gaseous media. It is used in the clean room, medical and filter technology, ventilation and air conditioning ducts, spray booths, large-scale catering facilities, for filter monitoring and level measurement or for triggering frequency converters. A **pressure sensor** with piezoresistive measuring element guarantees exact measurement results. The following measured values can be accessed via the Modbus: Differential pressure [Pa], volume flow [m³/h].

**Innovative Modbus sensor** with galvanically separated RS485 Modbus interface, selectable bus termination resistance, DIP switch for setting the bus parameters and bus address in current-free state, LEDs for telegram status display, two separate push-in terminals and large three-line display (illuminated; with customised programming in the 7-segment and dot-matrix range). The sensor is factory-calibrated; an environmental precision adjustment by an expert is possible.

PREMASGARD® 714x-Modbus



Device version with **M12 connector** (optional)



**TECHNICAL DATA**

Power supply:	24 V AC (±20%) and 15...36V DC
Power consumption:	< 4.8 W / 24 V DC typical; < 6.8 VA / 24 V AC typical
Pressure type:	Differential pressure
Data points:	Differential pressure [Pa], volume flow [m³/h]
Measuring range, pressure:	<b>-500... +500 Pa</b> or <b>-7000...+7000 Pa</b> depending on the device type, see table
Pressure accuracy:	<b>Type 7148</b> (500 Pa): typical ± 13 Pa <b>Type 7147</b> (7000 Pa): typical ± 105 Pa compared to a calibrated reference device
Above- / below-pressure:	max. ± 50 kPa
Zero point offset:	± 10 % measuring range
Hysteresis:	0.3% of final value
Linearity:	< ± 1 % of final value
Temp. drift values:	± 0.1 % / °C
Long-term stability:	± 1 % per year
Bus protocol:	Modbus (RTU mode), address range 0... <b>247</b> selectable
Signal filtering:	0 s / 1 s / 10 s
Pressure connection:	with metal nozzles for pressure hose Ø 6 mm
Medium:	clean air and non-aggressive, non-combustible gases
Media contacting parts:	Brass, Ni, Duroplast, Si, epoxy, RTV, BSG, UV silicone gel
Media temperature:	-20...+50 °C (temperature-compensated 0...+50 °C)
Ambient temperature:	-30...+70 °C
Permissible humidity:	0...95% r. H. (non-precipitating air)
Housing:	plastic, UV-resistant, polyamide material, 30% glass-globe reinforced, with quick-locking screws (slotted / Phillips head combination), colour traffic white (similar to RAL 9016), housing cover for display is transparent!
Housing dimensions:	126 x 90 x 50 mm (Tyr2)
Cable connection:	<b>cable gland</b> plastic (M 16 x 1.5; with strain relief, exchangeable, inner diameter 10.4 mm) or <b>M12 connector</b> according to DIN EN 61076-2-101 (optional)
Electrical connection:	0.2-1.5 mm², via push-in terminals
Protection class:	III (according to EN 60 730)
Safety class:	<b>IP 65</b> (according to EN 60 529) in the built-in state
Standards:	CE-conformity, electromagnetic compatibility according to EN 61 326, EMC directive 2014 / 30 / EU
Optional:	<b>Illuminated display</b> , 3-line, programmable, cut-out approx. 70 x 40 mm (W x H), to display the actual pressure or volume flow or an individually programmable display value
<b>ACCESSORIES</b>	see table
<b>ASD-06</b>	<b>Connection set</b> (nipple straight) (included in the scope of delivery)

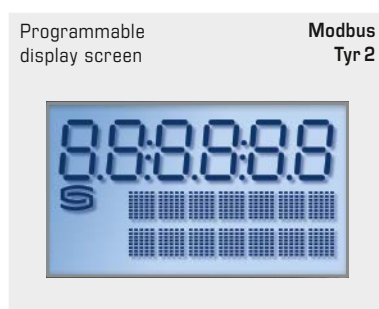
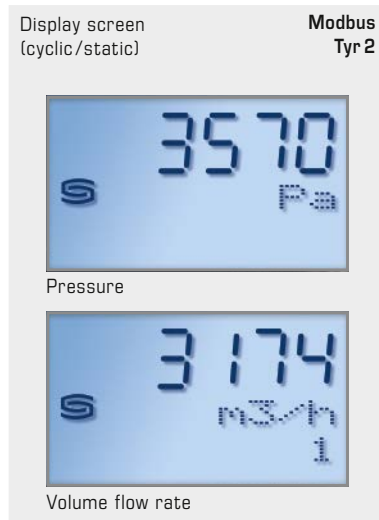



**NEW**

S+S REGELTECHNIK

PREMASGARD® 714x-Modbus

Pressure sensor and measuring transducer for differential pressure and volume flow, incl. connection set, calibratable, with Modbus connection

Dimensional drawing

PREMASGARD® 714x-Modbus

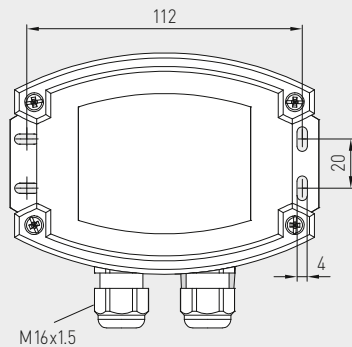
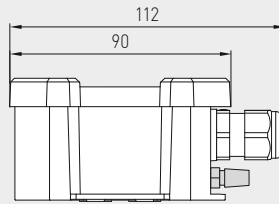
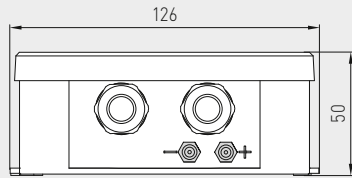

Pressure port nozzles, metal

PREMASGARD® 714x-Modbus with display



Device version with cable gland (as standard)



Mounting diagram

PREMASGARD® 714x-Modbus

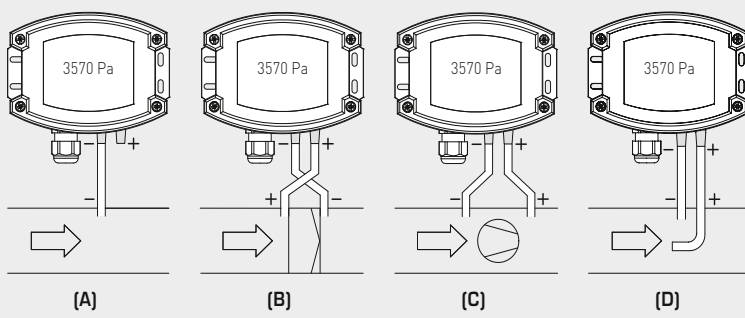

**TYPES OF MONITORING:**

Pressure connections at the pressure switch are marked with P1 (+) for higher pressure and P2 (-) for lower pressure.

- (A) Below-atmospheric pressure**  
P1 (+) is not connected, but open to the atmosphere  
P2 (-) connected to inside of duct
- (B) Filter**  
P1 (+) connected upstream of filter  
P2 (-) connected downstream of filter
- (C) Ventilator**  
P1 (+) connected downstream of ventilator  
P2 (-) connected upstream of ventilator
- (D) Volume flow**  
P1 (+) dynamic pressure, connected in flow direction  
P2 (-) static pressure, connected free of dynamic pressure components

Conversion table for pressure values:

Unit =	bar	mbar	Pa	kPa	mWS
1 Pa	0.00001 bar	0.01 mbar	1 Pa	0.001 kPa	0.000101971 mWS
1 kPa	0.01 bar	10 mbar	1000 Pa	1 kPa	0.101971 mWS
1 bar	1 bar	1000 mbar	100000 Pa	100 kPa	10.1971 mWS
1 mbar	0.001 bar	1 mbar	100 Pa	0.1 kPa	0.0101971 mWS
1 mWS	0.0980665 bar	98.0665 mbar	9806.65 Pa	9.80665 kPa	1 mWS

Pressure sensor and measuring transducer for differential pressure and volume flow, incl. connection set, calibratable, with Modbus connection

Dimensional drawing ASD-06 Connection set

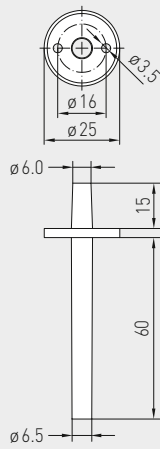

ASD-06 Connection set



Dimensional drawing ASD-07 Connection nipple

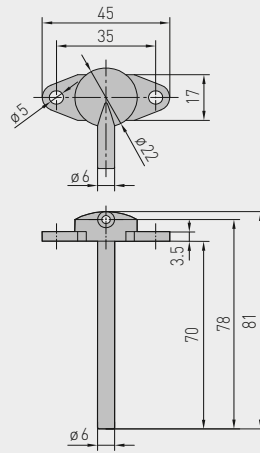

ASD-07 Connection nipple



Dimensional drawing DAL-01 Pressure outlet

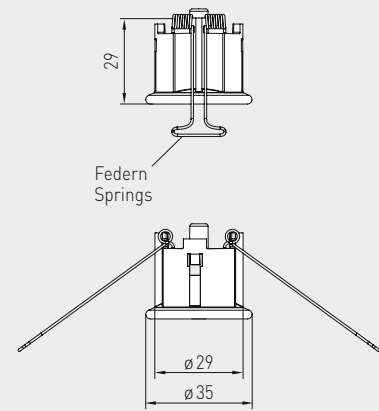

DAL-01 Pressure outlet



Schematic diagram PREMASGARD® 714x-Modbus

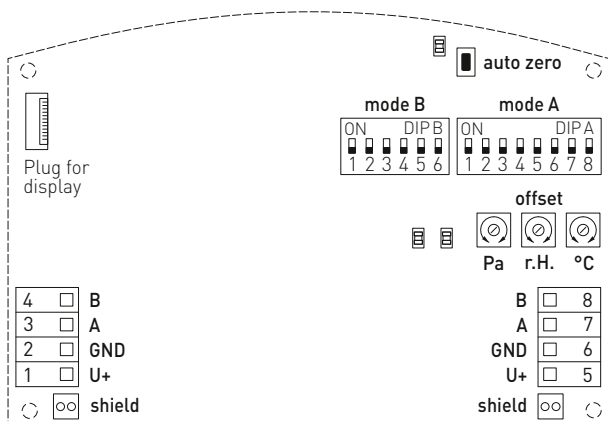

- DIP A: Bus address
- DIP B: Bus parameters (Baud rate, parity...)
- Telegram indicator Reception (LED green) Error (LED red)
- LED (internal status)
- Reset button
- Offset correction
- Shielding

WS-03 Weather and sun protection hood (optional)







Pressure sensor and measuring transducer for differential pressure and volume flow, incl. connection set, calibratable, with Modbus connection

PREMASGARD® 714x-Modbus  
with display,  
hinged



PREMASGARD® 714x-Modbus		Pressure sensor and measuring transducer for differential pressure and volume flow, <i>Deluxe</i>				
Measuring Range Pressure / Volume Flow	Type/WG02	Output	Display	Item no.	Price	
- 500...+ 500 Pa  k = 2000 44721 m <sup>3</sup> /h	<b>7148</b>					
	PREMASGARD 7148-Modbus	Modbus		1301-7164-0910-20V	<b>387,72 €</b>	
	PREMASGARD 7148-Modbus LCD	Modbus	■	1301-7164-4910-20V	<b>430,92 €</b>	
		<b>with automatic zero-point calibration as standard</b>				
- 7000...+ 7000 Pa  k = 2000 167332 m <sup>3</sup> /h	<b>7147</b>					
	PREMASGARD 7147-Modbus	Modbus		1301-7164-0950-200	<b>333,72 €</b>	
	PREMASGARD 7147-Modbus LCD	Modbus	■	1301-7164-4950-200	<b>376,92 €</b>	
		<b>with optional automatic zero point calibration</b> (Please specify in your order) on request				
Extra charge:	Cable connection with <b>M12 connector</b> according to DIN EN 61076-2-101			on request		
Measuring range:	The <b>pressure ranges</b> depend on the device type and can be set via Modbus.					

ACCESSORIES					
<b>KA2-Modbus</b>	<b>Communication adapter</b> (USB/RS485) for system connection			1906-1200-0000-100	<b>203,80 €</b>
<b>LA-Modbus</b>	<b>Line termination device</b> (with terminating resistor) as an active bus termination			1906-1300-0000-100	<b>76,01 €</b>
<b>ASD-06</b>	<b>Connection set (included in the scope of delivery)</b> , consisting of 2 connection nipples (straight) made of ABS, 2 m PVC hose (soft, UV-resistant) and 4 screws			7100-0060-3000-000	<b>7,28 €</b>
<b>ASD-07</b>	<b>2 connection nipples</b> (at 90 degree angle) made of plastic, ABS			7100-0060-7000-000	<b>7,28 €</b>
<b>DAL-01</b>	<b>Pressure outlet</b> for ceiling or in-wall installation (e.g. in clean rooms)			7300-0060-3000-001	<b>34,07 €</b>
<b>WS-03</b>	<b>Weather and sun protection hood</b> , 200 x 180 x 150 mm, stainless steel <b>V2A</b> (1.4301)			7100-0040-6000-000	<b>42,61 €</b>

For further information, see chapter Accessories!

**Dual pressure sensor (2 measuring channels), measuring transducer for differential pressure and volume flow, incl. connection set, calibratable, with Modbus connection**

Maintenance-free, microprocessor-controlled **PREMASGARD® 724x-Modbus** (series) with Modbus connection, impact-resistant plastic housing, optionally with /without display, with cable gland or M12 connector according to DIN EN 61076-2-101, for measuring the differential pressure (max. -7000...+7000 Pa) in air. Incl. connection set **ASD-06** (2m connecting hose, two pressure port nipples, screws). Type variant **724xT** with connection facility for external **Pt1000** sensor (sensor element not included in the scope of delivery) for detecting the temperature (-50...+150°C).

The pressure sensor is applied to measure positive, negative or differential pressure in clean air and gaseous media. It is used in the clean room, medical and filter technology, ventilation and air conditioning ducts, spray booths, large-scale catering facilities, for filter monitoring and level measurement or for triggering frequency converters. A **pressure sensor** with piezoresistive measuring element guarantees exact measurement results. The following measured values can be accessed via the Modbus: Differential pressure [Pa], volume flow [m³/h] and temperature [°C].

**Innovative Modbus sensor** with galvanically separated RS485 Modbus interface, selectable bus termination resistance, DIP switch for setting the bus parameters and bus address in current-free state, LEDs for telegram status display, two separate push-in terminals and large three-line display (illuminated; with customised programming in the 7-segment and dot-matrix range). The sensor is factory-calibrated; an environmental precision adjustment by an expert is possible.

**PREMASGARD® 724x-Modbus** with cable gland



**PREMASGARD® 724x-Modbus-Q** with M12 connector



**PREMASGARD® 724xT-Modbus** with cable gland



**TECHNICAL DATA**

Power supply:	24 V AC (±20%) and 15...36V DC
Power consumption:	< 4.8 W / 24 V DC typical; < 6.8 VA / 24 V AC typical
Pressure type:	differential pressure <b>(2 measuring channels)</b>
Data points:	differential pressure [Pa], volume flow [m³/h], temperature [°C] – <b>Type 724xT</b> with connection facility for external Pt1000 sensor (sensor element not included in the scope of delivery)
Measuring range, pressure:	<b>-500... +500 Pa</b> or <b>-7000...+7000 Pa</b> depending on the device type, see table
Pressure accuracy:	<b>Type 7249</b> (500 Pa): typical ± 13 Pa <b>Type 724x</b> (7000 Pa): typical ± 105 Pa compared to a calibrated reference device
Above- / below-pressure:	max. ± 50 kPa
Zero point offset:	± 10 % measuring range
Hysteresis:	0.3 % of final value
Linearity:	< ± 1 % of final value
Temp. drift values:	± 0.1 % / °C
Long-term stability:	± 1 % per year
Bus protocol:	Modbus (RTU mode), address range 0... <b>247</b> selectable
Signal filtering:	0 s / 1 s / 10 s at pressure (4 s / 32 s at temperature)
Pressure connection:	with nozzles for pressure hose Ø 6 mm
Medium:	clean air and non-aggressive, non-combustible gases
Media contacting parts:	brass, Ni, Duroplast, Si, epoxy, RTV, BSG, UV silicone gel
Media temperature:	-20...+50°C (temperature-compensated 0...+50°C)
Ambient temperature:	-30...+70 °C
Permissible humidity:	0...95 % r. H. (non-precipitating air)
Electrical connection:	0.2- 1.5 mm², via push-in terminals
Housing:	plastic, UV-resistant, polyamide material, 30% glass-globe reinforced, with quick-locking screws (slotted / Phillips head combination), colour traffic white (similar to RAL 9016), housing cover for display is transparent!
Housing dimensions:	126 x 90 x 50 mm (Tyr2)
Cable connection:	<b>cable gland</b> plastic (M 16 x 1.5; with strain relief, exchangeable, inner diameter 10.4 mm) or <b>M12 connector</b> according to DIN EN 61076-2-101
Protection class:	III (according to EN 60 730)
Safety class:	<b>IP 65</b> (according to EN 60 529) in the built-in state
Standards:	CE-conformity, electromagnetic compatibility according to EN 61 326, EMC directive 2014 / 30 / EU
Optional:	<b>display with illumination</b> , 3-line, programmable, cut-out approx. 70 x 40 mm (W x H), to display the ACTUAL pressure of both channels or the ACTUAL temperature (cyclic) or an individually programmable display value
<b>ACCESSORIES</b>	see table
<b>ASD-06</b>	<b>connection set</b> (nipple straight) (included in the scope of delivery)



**NEW**

S+S REGELTECHNIK

Dual pressure sensor (2 measuring channels),  
measuring transducer for differential pressure and volume flow,  
incl. connection set, calibratable, with Modbus connection

Dimensional drawing

PREMASGARD® 724x-Modbus

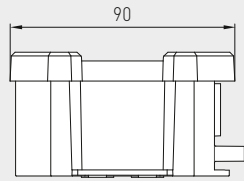
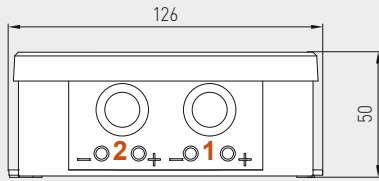

Housing with  
dual pressure connection  
(2 measuring channels)  
and cable gland

Housing with  
dual pressure connection  
(2 measuring channels)  
and M12 connector (male)

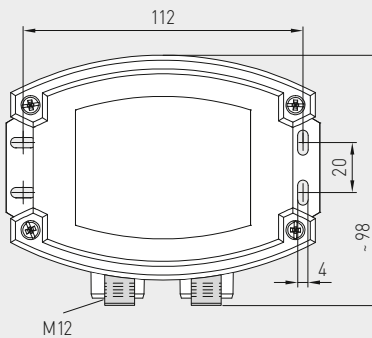
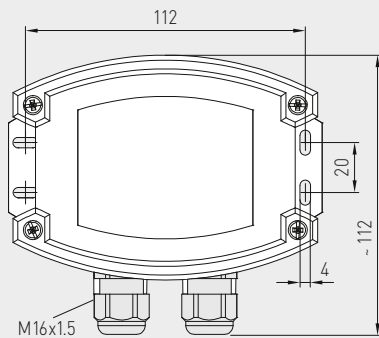

PREMASGARD® 724x-Modbus  
with cable gland  
and display



PREMASGARD® 724x-Modbus-Q  
with M12 connector  
and display



Dimensional drawing

PREMASGARD® 724xT-Modbus  
with connection facility  
for external Pt1000 sensor

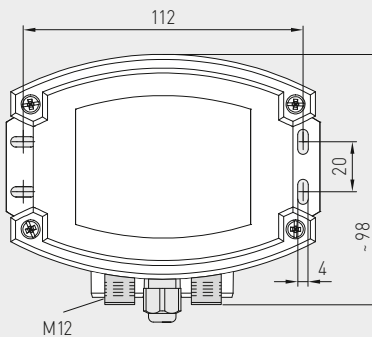
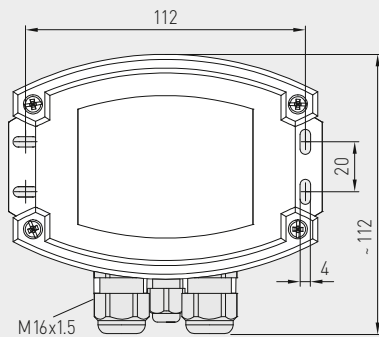

PREMASGARD® 724xT-Modbus  
with cable gland  
and display



Dual pressure sensor (2 measuring channels),  
measuring transducer for differential pressure and volume flow,  
incl. connection set, calibratable, with Modbus connection

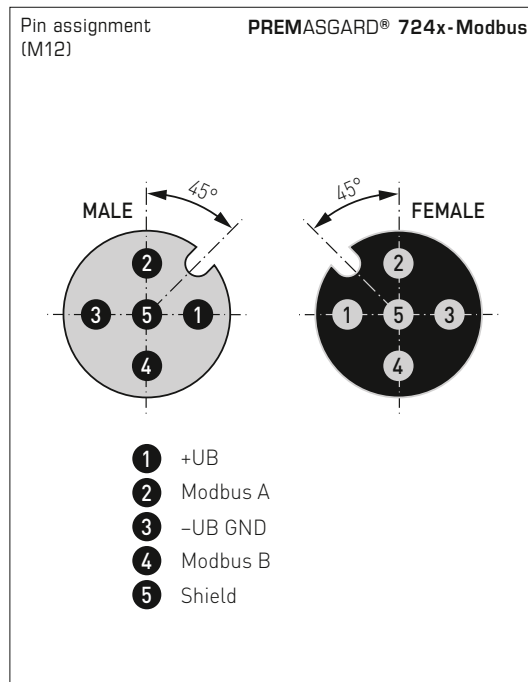
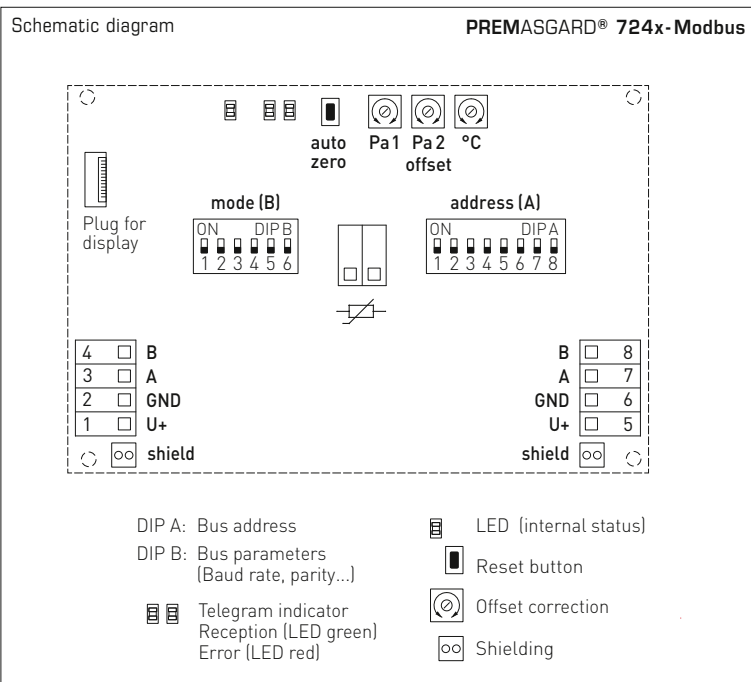

**Display screen (cyclic/static)** PREMASGARD® 724x-Modbus

Pressure (channel 1) Volume flow rate

Pressure (channel 2) Temperature (only type "T")

**Standard displays (programmable via Modbus)**

Actual **pressure** [Pa] of both channels is shown alternately. The associated measuring channel is visible at the bottom left.

Alternatively, the calculated **volume flow** [m<sup>3</sup>/h] can also be issued for channel 1 (via the index).

For the device type "T", the actual **temperature** [°C] of an external **Pt1000** temperature sensor can also be displayed as cyclic (standard) or static (via the index).

**Programmable display screen** Modbus Tyr 2





S+S REGELTECHNIK

NEW

Dual pressure sensor (2 measuring channels), measuring transducer for differential pressure and volume flow, incl. connection set, calibratable, with Modbus connection

PREMASGARD® 724x-Modbus with display, hinged

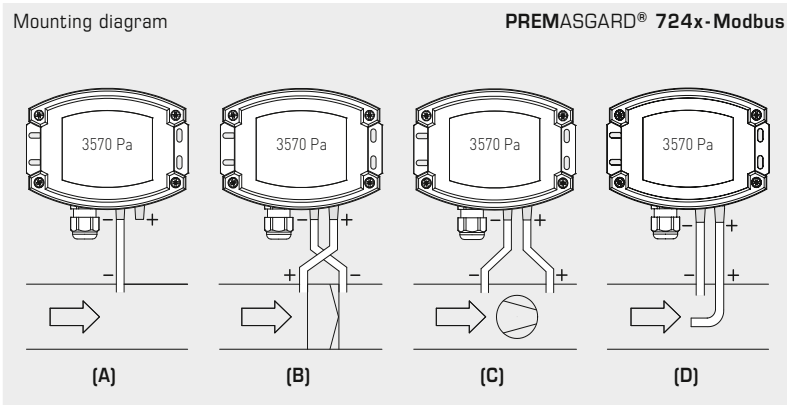

**TYPES OF MONITORING:**

Pressure connections at the pressure switch are marked with P1 (+) for higher pressure and P2 (-) for lower pressure.

- (A) Below-atmospheric pressure**  
P1 (+) is not connected, but open to the atmosphere  
P2 (-) connected to inside of duct
- (B) Filter**  
P1 (+) connected upstream of filter  
P2 (-) connected downstream of filter
- (C) Ventilator**  
P1 (+) connected downstream of ventilator  
P2 (-) connected upstream of ventilator
- (D) Volume flow**  
P1 (+) dynamic pressure, connected in flow direction  
P2 (-) static pressure, connected free of dynamic pressure components

**Conversion table for pressure values:**

Unit =	bar	mbar	Pa	kPa	mWS
1 Pa	0,00001 bar	0,01 mbar	1 Pa	0,001 kPa	0,000101971 mWS
1 kPa	0,01 bar	10 mbar	1000 Pa	1 kPa	0,101971 mWS
1 bar	1 bar	1000 mbar	100000 Pa	100 kPa	10,1971 mWS
1 mbar	0,001 bar	1 mbar	100 Pa	0,1 kPa	0,0101971 mWS
1 mWS	0,0980665 bar	98,0665 mbar	9806,65 Pa	9,80665 kPa	1 mWS

Dual pressure sensor (2 measuring channels),  
measuring transducer for differential pressure and volume flow,  
incl. connection set, calibratable, with Modbus connection

Dimensional drawing **ASD-06**  
Connection set

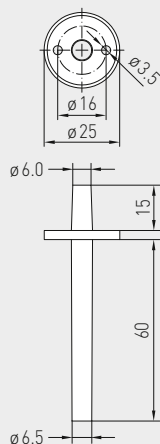

**ASD-06**  
Connection set



Dimensional drawing **ASD-07**  
Connection nipple

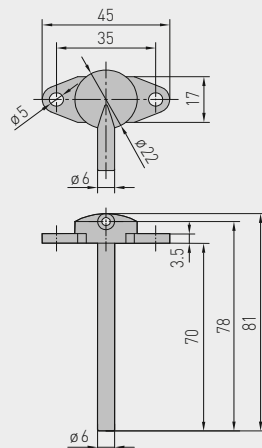

**ASD-07**  
Connection nipple



Dimensional drawing **DAL-01**  
Pressure outlet

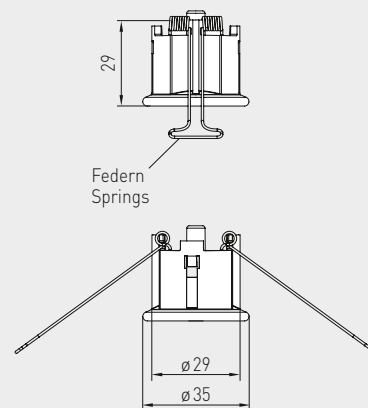

**DAL-01**  
Pressure outlet



**WS-03**  
Weather and sun protection hood  
(optional)

ACCESSORIES

<b>KA2-Modbus</b>	<b>Communication adapter</b> (USB/RS485) for system connection	1906-1200-0000-100	<b>203,80 €</b>
<b>LA-Modbus</b>	<b>Line termination device</b> (with terminating resistor) as an active bus termination	1906-1300-0000-100	<b>76,01 €</b>
<b>ASD-06</b>	<b>Connection set (included in the scope of delivery)</b> , consisting of 2 connection nipples (straight) made of ABS, 2 m PVC hose (soft, UV-resistant) and 4 screws	7100-0060-3000-000	<b>7,28 €</b>
<b>ASD-07</b>	<b>2 connection nipples</b> (at 90 degree angle) made of plastic, ABS	7100-0060-7000-000	<b>7,28 €</b>
<b>DAL-01</b>	<b>Pressure outlet</b> for ceiling or in-wall installation (e.g. in clean rooms)	7300-0060-3000-001	<b>34,07 €</b>
<b>WS-03</b>	<b>Weather and sun protection hood</b> , 200 x 180 x 150 mm, stainless steel V2A (1.4301)	7100-0040-6000-000	<b>42,61 €</b>

For further information, see chapter Accessories!



**NEW**

S+S REGELTECHNIK

PREMASGARD® 724x-Modbus

Dual pressure sensor (2 measuring channels),  
measuring transducer for differential pressure and volume flow,  
incl. connection set, calibratable, with Modbus connection

PREMASGARD® 724xT-Modbus  
with cable gland  
or M12 connector  
and connection facility for Pt1000

PREMASGARD® 724x-Modbus  
with cable gland  
or M12 connector



**PREMASGARD® 724x-Modbus** Dual pressure sensor (2 measuring channels), measuring transducer for differential pressure and volume flow, *Deluxe*

Pressure range (adjustable per channel)	Type/WG02	Output	Display ● = Q	Item No.	Price
(1) max. - 7000...+ 7000 Pa (2) max. - 7000...+ 7000 Pa	<b>Type 7247</b>				
Channel (1) and (2):	PREMASGARD 7247-Modbus	Modbus		1301-7224-0950-200	243,00 €
0 ... 1000 Pa / - 1000 ... + 1000 Pa	PREMASGARD 7247-Modbus LCD	Modbus	■	1301-7224-4950-200	289,44 €
0 ... 3000 Pa / - 3000 ... + 3000 Pa	PREMASGARD 7247T-Modbus	Modbus		1301-7224-0950-2W0	275,40 €
0 ... 5000 Pa / - 5000 ... + 5000 Pa	PREMASGARD 7247T-Modbus LCD	Modbus	■	1301-7224-4950-2W0	321,84 €
0 ... 7000 Pa / - 7000 ... + 7000 Pa	PREMASGARD 7247-Modbus Q	Modbus	●	2004-6331-6100-011	316,44 €
	PREMASGARD 7247-Modbus Q LCD	Modbus	● ■	2004-6332-6100-011	362,88 €
	PREMASGARD 7247T-Modbus Q	Modbus	●	2005-6331-6100-011	348,84 €
	PREMASGARD 7247T-Modbus Q LCD	Modbus	● ■	2005-6332-6100-011	395,28 €
(1) max. - 500... + 500 Pa (2) max. - 7000...+ 7000 Pa	<b>Type 7249</b>				
Channel (1):	PREMASGARD 7249-Modbus	Modbus		1301-7224-0930-200	243,00 €
0 ... 100 Pa / - 100 ... + 100 Pa	PREMASGARD 7249-Modbus LCD	Modbus	■	1301-7224-4930-200	289,44 €
0 ... 200 Pa / - 200 ... + 200 Pa	PREMASGARD 7249T-Modbus	Modbus		1301-7224-0930-2W0	275,40 €
0 ... 300 Pa / - 300 ... + 300 Pa	PREMASGARD 7249T-Modbus LCD	Modbus	■	1301-7224-4930-2W0	321,84 €
0 ... 500 Pa / - 500 ... + 500 Pa	PREMASGARD 7249-Modbus Q	Modbus	●	2004-6331-6100-001	316,44 €
Channel (2): see Type 7247	PREMASGARD 7249-Modbus Q LCD	Modbus	● ■	2004-6332-6100-001	362,88 €
	PREMASGARD 7249T-Modbus Q	Modbus	●	2005-6331-6100-001	348,84 €
	PREMASGARD 7249T-Modbus Q LCD	Modbus	● ■	2005-6332-6100-001	395,28 €
Multi-range switching:	The <b>pressure ranges</b> depend on the device type and are separately adjustable for each measuring channel via Modbus .				
Housing variant "Q":	Cable connection with <b>M12 connector</b> (male, 5-pin, A-code)				
Housing variant "T":	Connection facility for external <b>Pt1000</b> sensor (sensor element not included in the scope of delivery)				

**Multifunctional duct sensors and measuring transducers for humidity, temperature, pressure, differential pressure and volume flow, incl. mounting flange and connection set, calibratable, with Modbus connection**

Maintenance-free microprocessor-controlled **PREMASGARD® 814x - Modbus** (Series) with Modbus connection, in an impact-resistant plastic housing with quick-locking screws, optionally with/without display, with a plastic sinter filter (exchangeable), to exactly detect the relative humidity (0...100% r.H.) and the temperature (-35...+80 °C) in ducts and to measure the differential pressure (max. -7000...+7000 Pa) in air. Incl. mounting flange and connection set **ASD-06** (2m connecting hose, two pressure port nipples, screws).

The pressure sensor is applied to measure positive, negative or differential pressure in clean air and gaseous media. It is used in the clean room, medical and filter technology, ventilation and air conditioning ducts, spray booths, large-scale catering facilities, for filter monitoring and level measurement or for triggering frequency converters.

A long-term stable, **digital humidity and temperature sensor** and a **pressure sensor** with piezoresistive measuring element guarantee exact measurement results. These measurands are used to internally calculate the following parameters that can be retrieved via Modbus: temperature [°C], relative humidity [% r.H.], dew point [°C], absolute humidity [g/m³], mixture ratio [g/kg], enthalpy [kJ/kg] (ignoring atmospheric air pressure), differential pressure [Pa], volume flow [m³/h], air density [kg/m³].

**Innovative Modbus sensor** with galvanically separated RS485-Modbus-interface, selectable bus termination resistance, DIP switch for setting the bus parameters and bus address in current-free state, LEDs for telegram status display, two separate push-in terminals and large three-line display (illuminated; with customised programming in the 7-segment and dot-matrix range). The sensor is factory-calibrated; an environmental precision adjustment by an expert is possible.

**PREMASGARD® 814x - Modbus**  
with plastic sinter filter  
(standard)



## TECHNICAL DATA

Power supply:	24 V AC (±20%) and 15...36 V DC
Power consumption:	< 4.8 W / 24 V DC typical; < 6.8 VA / 24 V AC typical
Data points:	differential pressure [Pa], temperature [°C], relative humidity [% r.H.], dew point [°C], absolute humidity [g/m³], mixture ratio [g/kg], enthalpy [kJ/kg], volume flow [m³/h], air density [kg/m³]

## HUMIDITY

Sensors:	<b>digital humidity sensor with integrated temperature sensor</b> , low hysteresis, high long-term stability
Sensor protection:	<b>plastic sinter filter</b> , Ø 16 mm, L = 35 mm, exchangeable (optional <b>metal sinter filter</b> , Ø 16 mm, L = 32 mm)
Measuring range, humidity:	0...100% r. H.
Operating range, humidity:	0...95% r. H. (without dew formation)
Deviation in humidity:	typically <b>±2.0%</b> (20...80% r.H.) at +25 °C, otherwise ±3.0%

## TEMPERATURE

Measuring range, temperature:	-35...+80 °C
Deviation in temperature:	typically ±0.2 K at +25 °C

## PRESSURE

Type of pressure:	differential pressure
Pressure connection:	with metal <b>connection nozzles</b> for pressure hose Ø 6 mm (optional on request with <b>quick connect</b> for PVC fabric pressure hose Ø 6 mm)
Measuring range, pressure:	<b>-500... +500 Pa</b> or <b>-7000...+7000 Pa</b> depending on the type of device, see table
Accuracy, pressure:	<b>Type 8148</b> (500 Pa): typically ± 13 Pa at +25 °C <b>Type 8147</b> (7000 Pa): typically ± 105 Pa at +25 °C compared to the calibrated reference device
Above-/below-pressure:	max. ± 50 kPa
Zero point offset:	± 10 % of final value
Medium:	clean air and non-aggressive, non-combustible gases
Media contacting parts:	Brass, Ni, thermoset plastic, Si, epoxy, RTV, BSG, UV silicone gel
Media temperature:	-20...+50 °C (temperature-compensated 0...+50 °C)
Hysteresis:	0.3 % of final value
Linearity:	< ± 1 % of final value
Temp. drift values:	± 0.1 % / °C
Long-term stability:	± 1 % per year

Display screen (cyclic/static) **Modbus Tyr 2**



Pressure



Temperature



Humidity



Volume flow rate

Programmable display screen **Modbus Tyr 2**



Continued on next page!





Multifunctional duct sensors and measuring transducers for humidity, temperature, pressure, differential pressure and volume flow, incl. mounting flange and connection set, calibratable, with Modbus connection

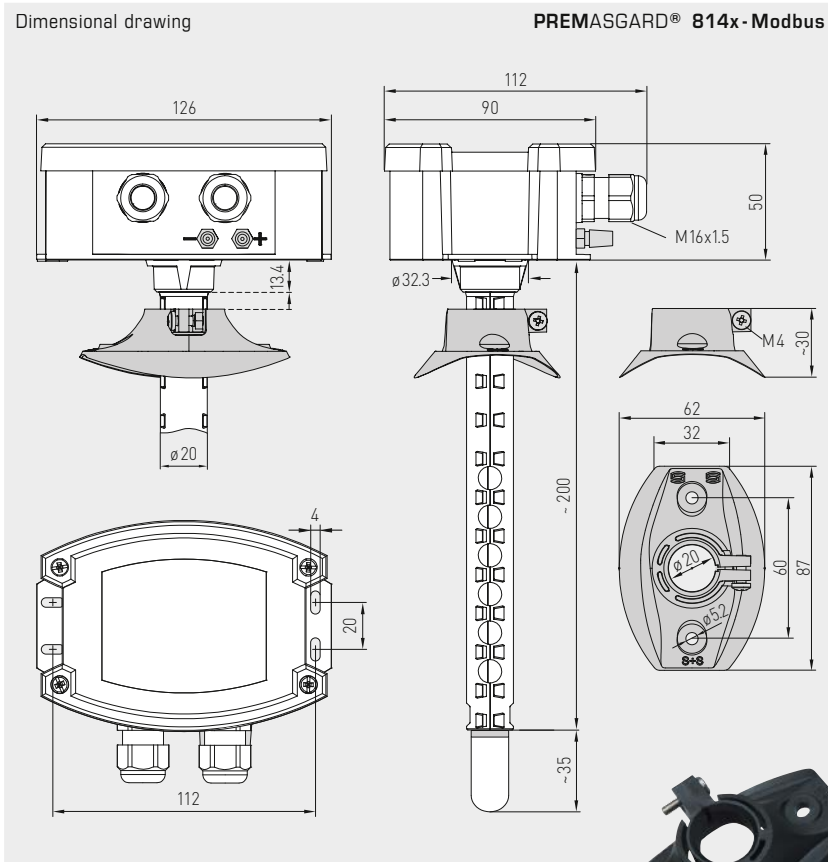

**MFT-20-K**  
Mounting flange, plastic



PREMASGARD® 814x-Modbus with display and plastic sinter filter (standard)



Device version with M12 connector (optional on request)



**TECHNICAL DATA** (continued)

Bus protocol:	Modbus (RTU mode), address range 0...247 adjustable
Signal filtering:	4 s / 32 s at temperature / humidity 0 s / 1 s / 10 s at pressure
Ambient temperature:	-30...+70 °C
Electrical connection:	0.2 - 1.5 mm <sup>2</sup> , via push-in terminal
Housing:	plastic, UV-resistant, material polyamide, 30% glass-globe reinforced, with quick-locking screws (slotted / Phillips head combination), colour traffic white (similar to RAL 9016), housing cover for display is transparent!
Housing dimensions:	126 x 90 x 50 mm (Tyr 2)
Cable connection:	<b>cable gland</b> , plastic (M 16 x 1.5; with strain relief, exchangeable, max. inner diameter 10.4 mm) or <b>M12 connector</b> according to DIN EN 61076-2-101 (optional on request)
Protective tube:	<b>PLEUROFORM™</b> , material: polyamide (PA6), with torsion protection, v <sub>max</sub> = 30 m/s (air), Ø 20 mm, (on request, optional stainless steel <b>V2A</b> (1.4301), Ø 16 mm) with plastic sinter filter: NL = 235 mm (optional with metal sinter filter: NL = 227 mm)
Process connection:	via mounting flange made of plastic (included in the scope of delivery)
Protection class:	III (according to EN 60 730)
Protection type:	IP 65 (according to EN 60 529) housing only! (PLEUROFORM IP 30)
Standards:	CE-conformity, electromagnetic compatibility according to EN 61 326, EMC Directive 2014 / 30 / EU
Optional:	three-line <b>display with illumination</b> , programmable, cut-out approx. 70 x 40 mm (W x H), for display actual humidity, actual temperature and ACTUAL pressure (cyclic) or a selectable parameter (static) or an individually programmable display value
<b>ACCESSORIES</b>	see table
<b>ASD-06</b>	<b>Connection set</b> (nipple straight) – (included in the scope of delivery)
<b>MFT-20K</b>	<b>Mounting flange</b> plastic (included in the scope of delivery)

Multifunctional duct sensors and measuring transducers  
for humidity, temperature, pressure, differential pressure and volume flow,  
incl. mounting flange and connection set,  
calibratable, with Modbus connection



Dimensional drawing ASD-06 Connection set

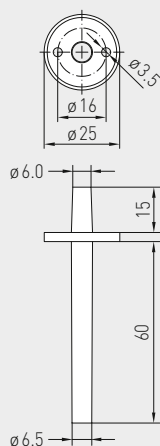

Dimensional drawing ASD-07 Connection nipple

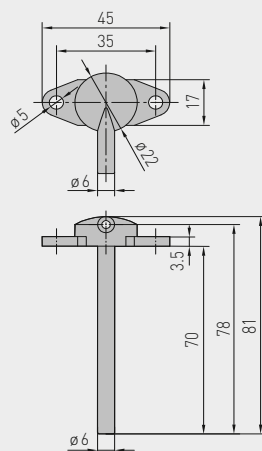

Dimensional drawing DAL-01 Pressure outlet

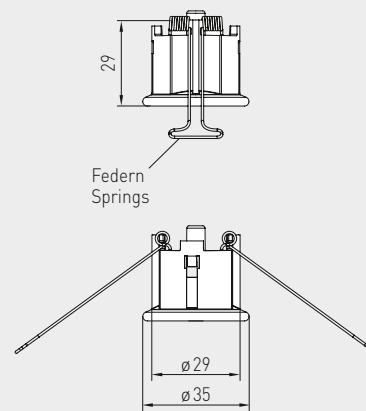

ASD-06 Connection set



ASD-07 Connection nipple



DAL-01 Pressure outlet



Mounting diagram PREMASGARD® 814x-Modbus

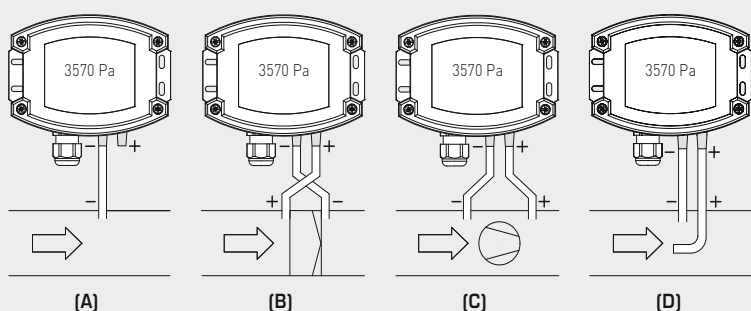

**TYPES OF MONITORING:**

Pressure connections at the pressure switch are marked with P1 (+) for higher pressure and P2 (-) for lower pressure.

- (A) **Below-atmospheric pressure**  
P1 (+) is not connected, but open to the atmosphere  
P2 (-) connected to inside of duct
- (B) **Filter**  
P1 (+) connected upstream of filter  
P2 (-) connected downstream of filter
- (C) **Ventilator**  
P1 (+) connected downstream of ventilator  
P2 (-) connected upstream of ventilator
- (D) **Volume flow**  
P1 (+) dynamic pressure, connected in flow direction  
P2 (-) static pressure, connected free of dynamic pressure components

**Conversion table for pressure values:**

Unit =	bar	mbar	Pa	kPa	mWS
1 Pa	0.00001 bar	0.01 mbar	1 Pa	0.001 kPa	0.000101971 mWS
1 kPa	0.01 bar	10 mbar	1000 Pa	1 kPa	0.101971 mWS
1 bar	1 bar	1000 mbar	100000 Pa	100 kPa	10.1971 mWS
1 mbar	0.001 bar	1 mbar	100 Pa	0.1 kPa	0.0101971 mWS
1 mWS	0.0980665 bar	98.0665 mbar	9806.65 Pa	9.80665 kPa	1 mWS



S+S REGELTECHNIK

# PREMASGARD® 814x-Modbus

Multifunctional duct sensors and measuring transducers for humidity, temperature, pressure, differential pressure and volume flow, incl. mounting flange and connection set, calibratable, with Modbus connection

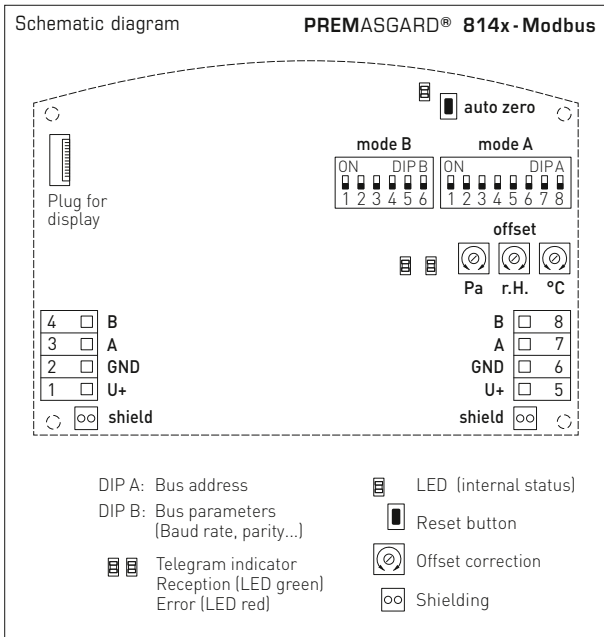

PREMASGARD® 814x-Modbus with display



**SF-K**  
Plastic sinter filter (standard)



**SF-M**  
Metal sinter filter (optional)

**stainless steel protective tube** (optional on request)

**PREMASGARD® 814x-Modbus** Multifunctional duct sensor for humidity, temperature, pressure, differential pressure and volume flow rate, *Deluxe*

Type / WG02	Measuring ranges	Humidity	Temperature	Output	Display	Item no.	Price
<b>PREMASGARD® 8148-Modbus</b>	<b>- 500...+ 500 Pa</b>						
PREMASGARD 8148-Modbus	-500...+ 500 Pa	0...100%r.H.	-35...+80°C	Modbus		1301-8144-0910-20V	<b>491,72 €</b>
PREMASGARD 8148-Modbus <b>LCD</b>	-500...+ 500 Pa	0...100%r.H.	-35...+80°C	Modbus	■	1301-8144-4910-20V	<b>537,00 €</b>
<b>Equipped as standard with automatic zero point calibration</b>							
<b>PREMASGARD® 8147-Modbus</b>	<b>- 7000...+ 7000 Pa</b>						
PREMASGARD 8147-Modbus	-7000...+ 7000 Pa	0...100%r.H.	-35...+80°C	Modbus		1301-8144-0950-200	<b>434,72 €</b>
PREMASGARD 8147-Modbus <b>LCD</b>	-7000...+ 7000 Pa	0...100%r.H.	-35...+80°C	Modbus	■	1301-8144-4950-200	<b>480,56 €</b>
Extra charge:	<b>with optional automatic zero point calibration</b> (please specify in your order)						<b>69,10 €</b>
Optional:	Cable connection with <b>M12 connector</b> according to DIN EN 61076-2-101						on request

ACCESSORIES			
<b>KA2-Modbus</b>	<b>Communication adapter</b> (USB/RS485) for system connection		1906-1200-0000-100 <b>203,80 €</b>
<b>LA-Modbus</b>	<b>Line termination device</b> (with terminating resistor) as an active bus termination		1906-1300-0000-100 <b>76,01 €</b>
<b>ASD-06</b>	<b>Connection set (included in the scope of delivery)</b> , consisting of 2 connection nipples (straight) made of ABS, 2 m PVC hose (soft, UV-resistant) and 4 screws		7100-0060-3000-000 <b>7,28 €</b>
<b>ASD-07</b>	<b>2 connection nipples</b> (at 90° angle) made of ABS		7100-0060-7000-000 <b>7,28 €</b>
<b>DAL-01</b>	<b>Pressure outlet</b> for ceiling or in-wall installation (e.g. in clean rooms)		7300-0060-3000-001 <b>34,07 €</b>
<b>SF-M</b>	<b>Metal sinter filter</b> , Ø 16 mm, L = 32 mm, exchangeable, stainless steel <b>V4A</b> (1.4404)		7000-0050-2200-100 <b>40,31 €</b>
<b>MFT-20-K</b>	<b>Mounting flange</b> , plastic (included in the scope of delivery)		7000-0031-0000-000 <b>9,10 €</b>

For further information see last chapter!

# AERASGARD® RC02 / RLQ - CO2 - Modbus AERASGARD® RFTM - LQ - PS - CO2 - Modbus

**NEW**



S+S REGELTECHNIK

**Multifunctional room sensor and measuring transducer for humidity, temperature, air quality (VOC), fine dust (PM) and CO2 content, calibratable, with Modbus connection**

Multifunctional indoor climate sensor **AERASGARD® RFTM - LQ - PS - CO2 - Modbus** (maximum expansion level) with Modbus connection, in an elegant plastic housing with snap-on lid, base with 4-hole attachment, optionally with / without display, type variant **RFTM - CO2 - Modbus** optionally with / without setpoint potentiometer.

The room sensor is used to detect the measurands air humidity (0...100% r.H.), temperature (0...+50°C), air quality (0...100% VOC), fine dust (PM) (0...1000 µg/m) and CO2 content (0...5000 ppm) as well as a room control unit (% setpoint).

Use just one device to monitor and control the entire indoor climate effectively. This enables energy-saving room ventilation on an as-needed basis, thereby reducing operating costs and improving well-being. It is used in offices, hotels, convention centres, apartments, shops, etc.

A long-term stable, **digital humidity and temperature sensor** guarantees exact measurement results. The air quality is determined based on a (VOC) **mixed gas sensor**. The CO2 content of the air is measured using an optical **NDIR sensor** (non-dispersive infra-red technology). An optical **fine dust sensor** precisely detects **particulate (PM)** of the size category 0.3 to 10 micrometres. The sensor is factory-calibrated; an environmental precision adjustment by an expert is possible. One sensor for every 30m² of room area is recommended.

**Modbus sensor** with galvanically separated RS485 Modbus interface, selectable bus termination resistance, DIP switches for setting the bus parameters and bus address in the currentless state, LEDs for telegram status display and two-line display (illuminated; with customised programming in the 7-segment and dot-matrix range).

**RFTM - CO2 - Modbus - P**  
with display and potentiometer



## TECHNICAL DATA

Power supply:	24 V AC / DC (± 10 %)
Power consumption:	typically < 4.4 W / 24 V DC; < 6.4 VA / 24 V AC; peak current 200 mA
Data points:	temperature [°C], relative humidity [% r.H.], air quality (VOC) [%,ppb], fine dust (PM) [µg/m³], carbon dioxide (CO2) [ppm], setpoint potentiometer [%]

## HUMIDITY & TEMPERATURE

Sensor (RH / °C):	<b>digital humidity sensor with integrated temperature sensor</b> , low hysteresis, high long-term stability
Deviation (RH):	typically <b>± 2.0 %</b> (20...80 % r.H.) at +25 °C, otherwise <b>± 3.0 %</b>
Deviation (°C):	typically <b>± 0.2 K</b> at +25 °C

## AIR QUALITY (VOC)

Sensor (VOC):	<b>VOC sensor</b> (metal oxide) <b>with automatic calibration</b> (VOC = volatile organic compounds)
Measuring range (VOC):	0...100% air quality; with reference to calibration gas; multi-range switching VOC sensitivity low, medium, high
Measuring accuracy (VOC):	typically <b>± 20 %</b> final value (with reference to the calibration gas)
Service life (VOC):	> 60 months (under normal load conditions)

## FINE DUST (PM)

Sensor (PM):	optical <b>particulate sensor</b> (PM = particulate matter), <b>fine-dust sensor</b> with laser- and soiling-resistant technology
Measuring range (PM):	0...1000 µg/m³
Particle size (PM):	<b>PM 2.5</b> (0.3...2.5 µm); <b>PM 10</b> (0.3...10 µm)
Measuring accuracy (PM):	typically <b>± 10 µg/m³</b> (± 10 % of measured value) at PM 2.5 typically <b>± 25 µg/m³</b> (± 25 % of measured value) at PM 10
Long-term stability (PM):	<b>± 1.25 µg/m³</b> (± 1.25 % of measured value/year)
Service life (PM):	> 10 years

## CARBON DIOXIDE (CO2)

Sensor (CO2):	optical <b>NDIR sensor</b> (non-dispersive infra-red technology) <b>with automatic and manual calibration</b>
Measuring range (CO2):	0...5000 ppm
Measuring accuracy (CO2):	typically <b>± 30 ppm</b> (± 3 % of measured value)
Temperature dependence (CO2):	<b>± 5 ppm / °C</b> or <b>± 0.5 %</b> of measured value / °C (whichever is greater)
Pressure dependence (CO2):	<b>± 0.13 % / mm Hg</b>
Long-term stability (CO2):	< 2 % in 15 years
Gas exchange (CO2):	Diffusion

Continued on next page!

Display screen  
**standard**

**Modbus**  
(Balduf)



Carbon dioxide (CO2)



Air quality (VOC)



Temperature



Humidity



Fine dust (PM)

Display screen  
**programmable**

**Modbus**  
(Balduf)



Symbols





**NEW**

S+S REGELTECHNIK

# AERASGARD® RC02 / RLQ-CO2 - Modbus AERASGARD® RFTM-LQ-PS-CO2 - Modbus

Multifunctional room sensor and measuring transducer  
for humidity, temperature, air quality (VOC), fine dust (PM) and CO2 content,  
calibratable, with Modbus connection

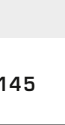

Dimensional drawing

Housing Baldur2

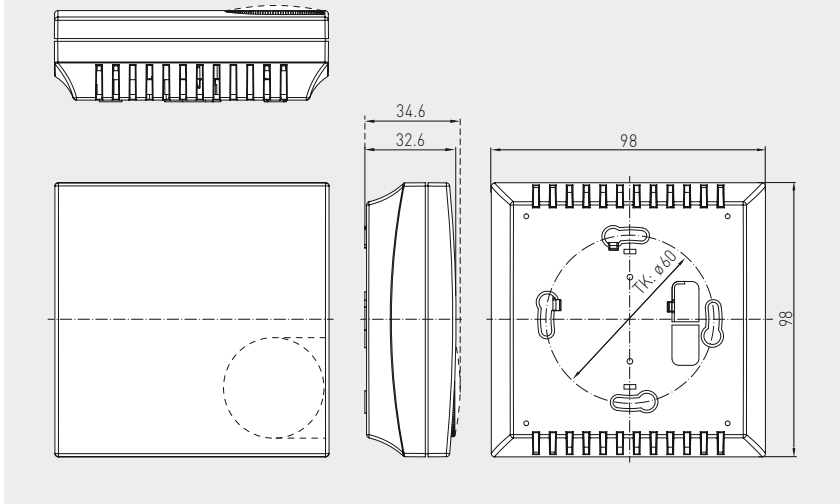

R xx CO2 - Modbus  
without display



RFTM-LQ-PS-CO2 - Modbus  
with display

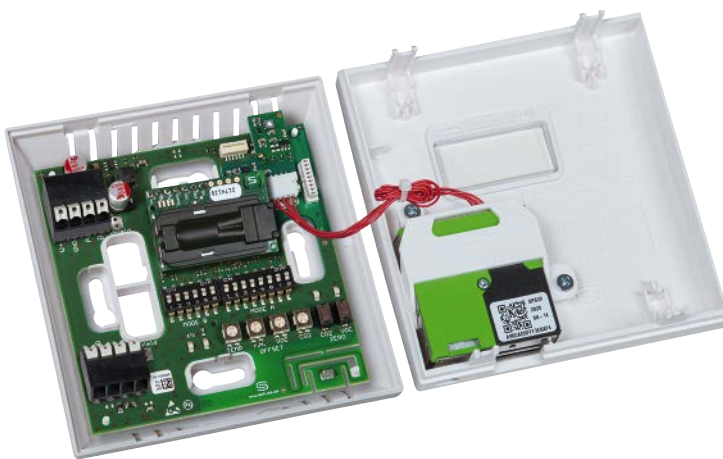

## TECHNICAL DATA (continued)

Ambient temperature:	0...+50 °C
Permitted humidity:	0...95% r. H. (non-precipitating air)
Warm up time:	approx. 1 hour
Response time:	< 2 minutes
Electrical connection:	0.2 - 1.5 mm <sup>2</sup> , via push-in terminal
Housing:	plastic, material ABS, colour pure white (similar to RAL 9010)
Dimensions:	98 x 98 x 33 mm (Baldur2)
Mounting:	wall mounting or on in-wall flush box, Ø55 mm, base with 4 holes, for attachment to vertically or horizontally installed in-wall flush boxes for rear cable entry, with predetermined breaking point for top/bottom cable entry for surface-mounted installation
Protection class:	III (according to EN 60 730)
Protection type:	IP 30 (according to EN 60 529)
Standards:	CE conformity, electromagnetic compatibility according to EN 61 326, EMC Directive 2014 / 30 / EU, Low Voltage Directive 2014 / 35 / EU
Optional:	<b>Display with illumination</b> , 2-line, cutout approx. 36 x 15 mm (W x H), to display actual humidity, actual temperature, air quality, of the fine-dust and CO2 content (cyclic) or a selectable parameter (static) or an individually programmable display value

Multifunctional room sensor and measuring transducer  
 for humidity, temperature, air quality (VOC), fine dust (PM) and CO2 content,  
 calibratable, with Modbus connection

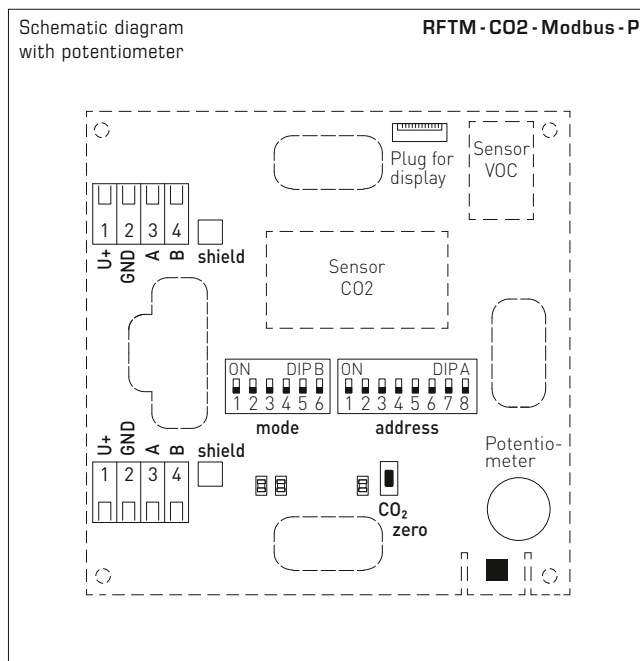
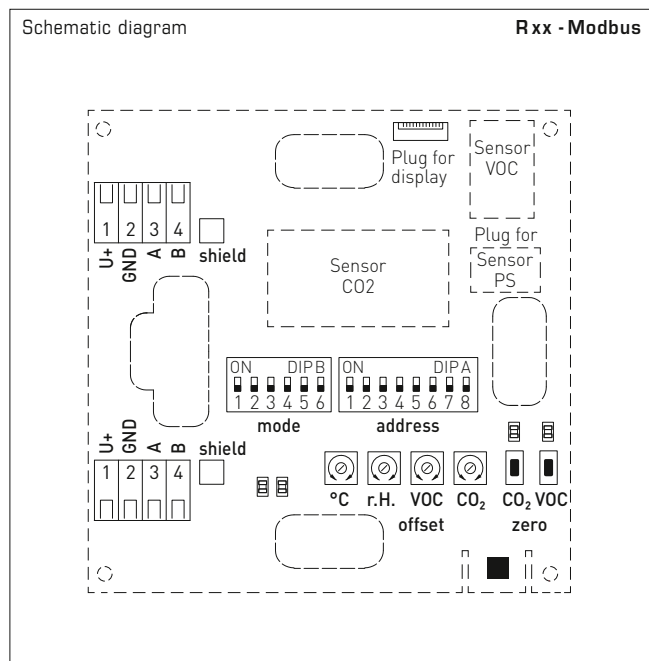

Display screen **standard (cyclic)**

Carbon dioxide (CO2)  
 Air quality (VOC)  
 Temperature  
 Humidity  
 Fine dust (PM)

Display screen **alternative (static)**

Carbon dioxide (CO2)  
 Air quality (VOC)  
 Temperature  
 Humidity  
 Fine dust (PM)

Display screen **Modbus programmable** (Balduz)

Symbols

The Modbus interface allows the display to be **individually** configured both in the 7-segment range and in the dot-matrix range. For improved legibility, backlighting is provided.

By default, the display indicates the measurements with the corresponding units **cyclically** and consecutively:

**CO2 content** in ppm, **air quality (VOC)** in %, **temperature** in °C, **relative humidity** in % r.H., **fine dust (PM)** in µg/m<sup>3</sup>.

The **Modbus** configuration can be used to program an **alternative output variable** instead of the standard display. In this case, the first line indicates the value and index while the second line indicates the corresponding unit **statically**. The index identifies the display type:

- Index 1** = carbon dioxide (CO2) [ppm]
- Index 2** = air quality (VOC) [%]
- Index 3** = temperature [°C]
- Index 4** = relative humidity [% r.H.]
- Index 6** = fine dust (PM) [µg/m<sup>3</sup>]



**NEW**

S+S REGELTECHNIK

**AERASGARD® RCO2 / RLQ - CO2 - Modbus**  
**AERASGARD® RFTM - LQ - PS - CO2 - Modbus**

Multifunctional room sensor and measuring transducer for humidity, temperature, air quality (VOC), fine dust (PM) and CO2 content, calibratable, with Modbus connection

**RFTM - CO2 - Modbus - P**  
with setpoint potentiometer (room control unit)



**RFTM - LQ - PS - CO2 - Modbus**  
with display



**Rxx CO2 - Modbus**  
without display



**AERASGARD® Rxx - Modbus** Room sensor and measuring transducer for humidity, temperature, air quality (VOC), fine dust (PM) and CO2 content, *Deluxe*

Type / WG02	Measuring Range				Display ☼=P	Item No.	Price
	Humidity	Temperature	PM	CO2			
<b>RCO2 - Modbus</b>							
RCO2-Modbus	-	-	-	5000 ppm	-	1501-61B0-6001-200	<b>259,63 €</b>
RCO2-Modbus LCD	-	-	-	5000 ppm	■	1501-61B0-6021-200	<b>307,10 €</b>
<b>RLQ - CO2 - Modbus</b>							
RLQ-CO2-Modbus	-	-	-	5000 ppm	0...100%	1501-61B1-6001-500	<b>380,57 €</b>
RLQ-CO2-Modbus LCD	-	-	-	5000 ppm	0...100%	■ 1501-61B1-6021-500	<b>428,03 €</b>
<b>RFTM - PS - Modbus</b>							
RFTM-PS-Modbus	0...100% r.H.	0...+50 °C	0...1000 µg/m³	-	-	1501-2116-6001-200	<b>353,85 €</b>
RFTM-PS-Modbus LCD	0...100% r.H.	0...+50 °C	0...1000 µg/m³	-	-	■ 1501-2116-6021-200	<b>406,59 €</b>
<b>RFTM - CO2 - Modbus</b>							
RFTM-CO2-Modbus	0...100% r.H.	0...+50 °C	-	5000 ppm	-	1501-61B6-6001-200	<b>306,35 €</b>
RFTM-CO2-Modbus LCD	0...100% r.H.	0...+50 °C	-	5000 ppm	-	■ 1501-61B6-6021-200	<b>353,58 €</b>
<b>RFTM - CO2 - Modbus - P</b>							
RFTM-CO2-Modbus-P	0...100% r.H.	0...+50 °C	-	5000 ppm	- ☼	1501-61B6-6501-271	<b>339,02 €</b>
RFTM-CO2-Modbus-P LCD	0...100% r.H.	0...+50 °C	-	5000 ppm	- ☼ ■	1501-61B6-6521-271	<b>386,48 €</b>
<b>RFTM - LQ - CO2 - Modbus</b>							
RFTM-LQ-CO2-Modbus	0...100% r.H.	0...+50 °C	-	5000 ppm	0...100%	1501-61B8-6001-500	<b>415,13 €</b>
RFTM-LQ-CO2-Modbus LCD	0...100% r.H.	0...+50 °C	-	5000 ppm	0...100%	■ 1501-61B8-6021-500	<b>462,59 €</b>
<b>RFTM - LQ - PS - CO2 - Modbus</b>							
RFTM-LQ-PS-CO2-Modbus	0...100% r.H.	0...+50 °C	0...1000 µg/m³	5000 ppm	0...100%	1501-2119-6001-500	<b>536,31 €</b>
RFTM-LQ-PS-CO2-Modbus LCD	0...100% r.H.	0...+50 °C	0...1000 µg/m³	5000 ppm	0...100%	■ 1501-2119-6021-500	<b>583,76 €</b>
<b>Housing variant "P":</b>	<b>Room control unit</b> with potentiometer (standard printing is a widening arrow with central position unfilled)						
<b>Note:</b>	These units must <b>not</b> be used as safety-relevant devices!						

**ACCESSORIES**

<b>KA2-Modbus</b>	Communication adapter (USB/RS485) for system connection	1906-1200-0000-100	<b>203,80 €</b>
<b>LA-Modbus</b>	Line termination device (with terminating resistor) as an active bus termination	1906-1300-0000-100	<b>76,01 €</b>

**Room humidity, temperature and CO2 sensor or measuring transducer, in-wall in the panel switch programme, with Modbus connection**

The room sensor and measuring transducer **AERASGARD® FSFTM - CO2 - Modbus** in the in-wall housing, optionally with potentiometer, is used to measure the CO2 content, relative humidity and temperature of the air, and for setpoint adjustment. The measured values are queried via the Modbus interface.

The CO2 content of the air is measured using an optical NDIR sensor (non-dispersive infra-red technology). A digital, long-term stable sensor is used for humidity and temperature measurement. Relative humidity [% r.H.] is the quotient of water vapour partial pressure divided by the saturation vapour pressure at the respective gas temperature.

The in-wall sensor is mounted in high-quality panel switch programmes, ideally of the brands Gira, Berker, Merten, Jung, Siemens or Busch-Jaeger (using in-wall adapters, no setpoint adjustment possible) either individually or in combination with light switches, socket outlets, etc.

It is used in non-aggressive, dust-free environments, in refrigeration, air conditioning and clean room technology, and in interior rooms, such as living rooms, offices, hotels, etc.

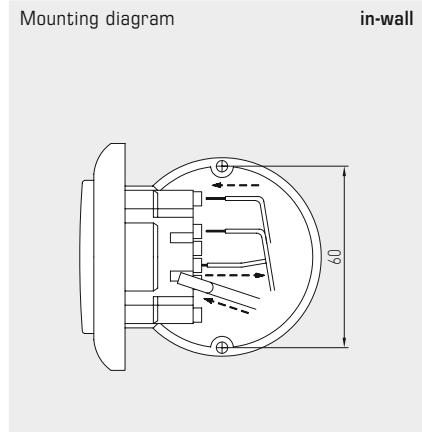

**TECHNICAL DATA**

Power supply:	24 V AC / DC (± 10%)
Power consumption:	< 4.4 W / 24 V DC; < 6.4 VA / 24 V AC
Data points:	relative humidity [% r.H.], temperature [°C], CO2 content of the air [ppm] as well as setpoint potentiometer (no setpoint adjustment possible with Busch-Jaeger)
Bus protocol:	Modbus (RTU mode), address range 0...247 selectable
Signal filtering:	4 s / 32 s

**CARBON DIOXIDE (CO2)**

Sensor, CO2:	<b>optical NDIR sensor</b> (non-dispersive infra-red technology), with manual calibration (via zero button) and automatic calibration (fixed)
Long-term stability:	< 2% in 15 years
Measuring range, CO2:	0...5000 ppm
Measuring accuracy, CO2:	typically ± 30 ppm ± 3% of measured value
Temperature dependence, CO2:	± 5 ppm / °C or ± 0.5% of measured value / °C (whichever is higher)
Pressure dependence:	± 0.13% / mm Hg
Gas exchange:	by diffusion
Warm up time:	approx. 1 hour
Response time:	< 2 minutes

**HUMIDITY**

Sensor:	<b>digital humidity sensor with integrated temperature sensor</b> , low hysteresis, high long-term stability
Long-term stability:	± 1% per year
Measuring range, humidity:	0...100% r.H.
Operating range, humidity:	0...95% r.H. (non-precipitating air)
Deviation, humidity:	typically ± 3.0% (20...80% r.H.) at +25 °C, otherwise ± 5.0%

**TEMPERATURE**

Measuring range:	0...+50 °C
Deviation, temperature:	typically ± 0.8K at +25 °C

Mounting:	in-wall flush box Ø 55 mm
Electrical connection:	1.0 - 2.5 mm <sup>2</sup> , via plug terminals
Ambient temperature:	Storage -35...+85 °C; Operation 0...+50 °C
Permitted humidity:	max. 90% r.H., non-precipitating air
Medium:	clean air and other non-aggressive, non-combustible gases
Protection class:	III (according to EN 60 730)
Protection type:	<b>IP 20</b> (according to 60 529)
Standards:	CE-conformity, electromagnetic compatibility according to EN 61 326, EMC Directive 2014 / 30 / EU

**SWITCH PROGRAMME**

Manufacturer:	GIRA System 55 (other switch programmes, manufacturers, colours as well as prices available upon request)
Housing:	plastic, the standard colour is pure glossy white (similar to RAL 9010) (other colours are available upon request with colour variants depending on the respective light switch programme)

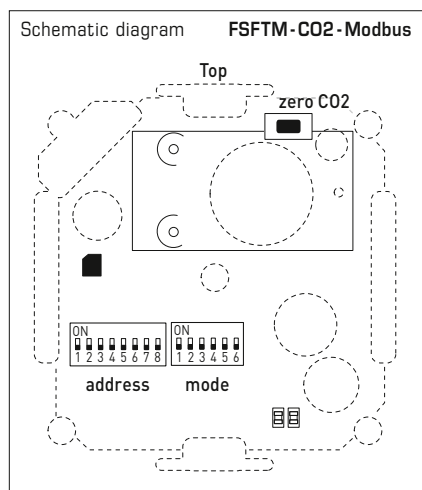
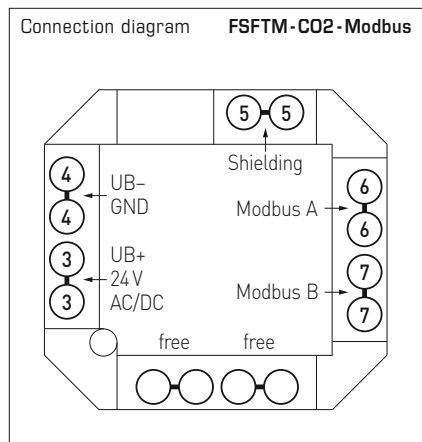





S+S REGELTECHNIK

Room humidity, temperature and CO2 sensor or measuring transducer, in-wall in the panel switch programme, with Modbus connection

Dimensional drawing

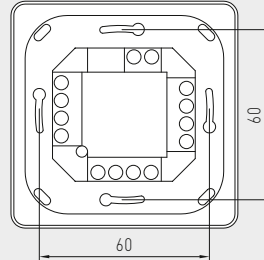
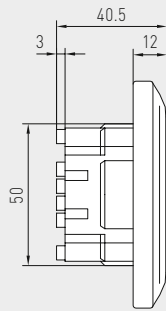
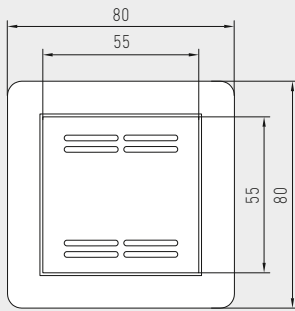

FSFTM - CO2 - Modbus

FSFTM - CO2 - Modbus Standard



Dimensional drawing

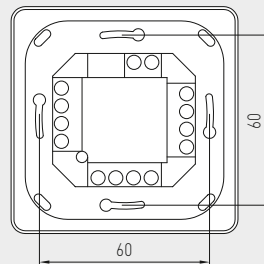
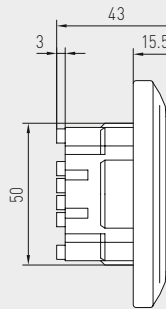
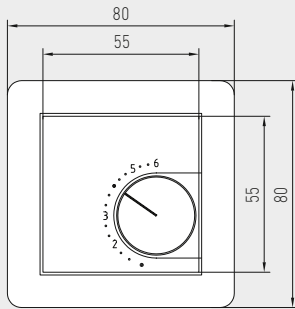

FSFTM - CO2 - Modbus - P

FSFTM - CO2 - Modbus - P with potentiometer



AERASGARD® FSFTM - CO2 - Modbus Room temperature humidity and CO2 sensor, in-wall

Type / WG02	Measuring Range CO2	Humidity	Temperature	Control element	Output	Item No.	Price
<b>FSFTM - CO2 - Modbus</b>							
FSFTM-CO2-Modbus	0...5000 ppm	0...100% r. H.	0...+50 °C	-	Modbus	1501-9226-6001-162	356,81 €
FSFTM-CO2-Modbus P	0...5000 ppm	0...100% r. H.	0...+50 °C	Potentiometer	Modbus	1501-9226-6501-282	440,37 €

**Data points:** relative humidity [% r. H.], temperature [°C], CO2 content of the air [ppm] and setpoint potentiometer

**ACCESSORIES**

<b>KA2-Modbus</b>	<b>Communication adapter</b> (with USB and RS485 interface) for system connection (incl. quick-start software)	1906-1200-0000-100	203,80 €
<b>LA-Modbus</b>	<b>Line termination device</b> (with terminating resistor) as an active bus termination of RS485 networks	1906-1300-0000-100	76,01 €

# AERASGARD® AC02 / ALQ-CO2 - Modbus

## AERASGARD® AFTM-(LQ)-CO2 - Modbus



S+S REGELTECHNIK

**Multifunctional on-wall sensors and measuring transducers, for humidity, temperature, CO2 content and air quality (VOC), calibratable, with Modbus connection**

The maintenance-free, microprocessor-controlled **AERASGARD® AFTM-LQ-CO2-Modbus** and **AC02 / ALQ-CO2 / AFTM-CO2-Modbus** with Modbus connection, with/without optional display, is designed for on-wall installation and is used to monitor all measurands of relevance to the climate inside a room. These are the measurands air humidity, temperature, CO2 concentration as well as air quality (VOC). By using a single device to monitor all four measurands, it is possible to effectively monitor and regulate the entire room climate. It measures CO2 in the range of 0...5000 ppm, VOC at one of three selectable sensitivity levels LOW / MEDIUM / HIGH, temperatures in the range of -35...+80 °C, as well as relative air humidity from 0...100% r.H.

A digital, long-term stable sensor used as measuring element for relative air humidity and temperature guarantees exact measurement results. The Modbus can be used to retrieve the following parameters: Temperature [°C], relative humidity [% r.H.], air quality (VOC) [%], carbon dioxide (CO2) [ppm] and atmospheric pressure [hPa].

The CO2 content of the air is measured using an optical NDIR sensor (non-dispersive infra-red technology). The detection range of the sensors is calibrated for standard applications such as monitoring residential rooms and conference rooms. Room ventilation on an as-needed basis, improved well-being and customer benefit, increased comfort as well as reduced operating costs through energy conservation are just some of the benefits of employing the AERASGARD® CO2 sensor. One sensor for every 30 m² of room area is recommended.

The explanations above demonstrate that there are applications for CO2 measurements, for VOC measurements, but from our perspective, above all, for a combination of both measurands. The crucial factor in this respect is that both of these measurands are not convertible into each other and derivations to or from one another cannot be made. An NDIR CO2 measuring instrument measures selectively and cannot detect any VOC; a VOC mixed gas sensor cannot recognize CO2 molecules.

### TECHNICAL DATA

Voltage supply:	24 V AC / DC (± 10%)
Power consumption:	< 4.8 W / 24 V DC typical; < 6.8 VA / 24 V AC typical; peak current 200 mA
Data points:	Temperature [°C], relative humidity [% r.H.], air quality (VOC) [%], carbon dioxide (CO2) [ppm], atmospheric pressure [hPa]

### HUMIDITY

Sensors:	<b>digital humidity sensor with integrated temperature sensor,</b> low hysteresis, high long-term stability
Sensor protection:	<b>plastic sinter filter</b> , Ø 16 mm, L = 35 mm, exchangeable (optional <b>metal sinter filter</b> , Ø 16 mm, L = 32 mm)
Measuring range, humidity:	0...100% r. H.
Operating range, humidity:	0...95% r. H. (without dew formation)
Deviation of humidity:	typically <b>± 2.0%</b> (20...80% r. H.) at +25 °C, otherwise ± 3.0%

### TEMPERATURE

Measuring range, temperature:	-35...+80 °C
Operating range, temperature:	-10...+60 °C
Deviation, temperature:	typically ± 0.4 K at 25 °C

### AIR QUALITY (VOC)

Sensor, VOC:	VOC sensor (metal oxide) <b>with automatic calibration</b> (VOC = volatile organic compounds)
Measuring range, VOC:	0...100% air quality; referred to calibrating gas; <b>multi-range switching</b> VOC sensitivity low, medium, high
Measuring accuracy, VOC:	± 20% of final value (referred to calibrating gas)
Service life:	> 60 months (under normal load conditions)

### CARBON DIOXIDE (CO2)

Sensor, CO2:	optical NDIR sensor (non-dispersive infra-red technology) including atmospheric pressure compensation (up to 1100 mbar) <b>with automatic and manual calibration</b>
Measuring range, CO2:	0...5000 ppm
Measuring accuracy, CO2:	typically ± 30 ppm ± 3% of measured value
Temperature dependence, CO2:	± 5 ppm / °C or ± 0.5% of measured value / °C (whichever is higher)
Pressure dependence:	± 0.13% / mm Hg
Long-term stability:	< 2% in 15 years
Gas exchange:	by diffusion

(continued on next page!)

Display screen (cyclic) Modbus Tyr 2



Temperature



Humidity



Air quality (VOC)



Carbon dioxide (CO2)

Display screen (static) Modbus Tyr 2



Carbon dioxide (CO2)



Atmospheric pressure

Programmable display screen Modbus Tyr 2





S+S REGELTECHNIK

# AERASGARD® AC02 / ALQ-CO2 - Modbus AERASGARD® AFTM-(LQ)-CO2 - Modbus

Multifunctional on-wall sensors and measuring transducers,  
for humidity, temperature, CO2 content and air quality (VOC),  
calibratable, with Modbus connection

Dimensional drawing

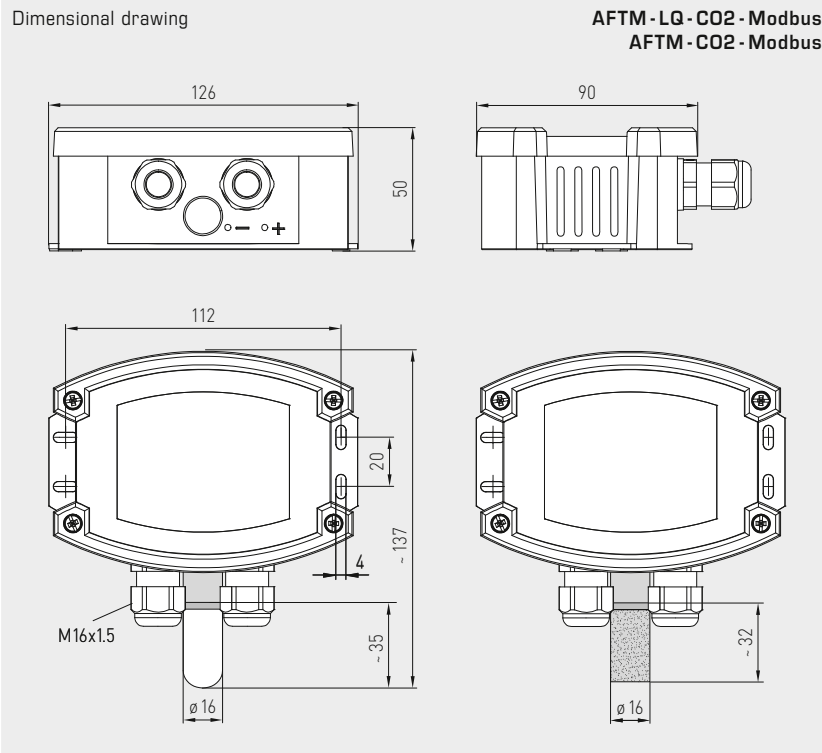

**AFTM-LQ-CO2-Modbus**  
**AFTM-CO2-Modbus**  
with plastic sinter filter  
(standard)



**AFTM-LQ-CO2-Modbus**  
**AFTM-CO2-Modbus**  
with display and  
plastic sinter filter  
(standard)



**SF-K**  
Plastic sinter filter  
(standard)



**SF-M**  
Metal sinter filter  
(optional)

TECHNICAL DATA		(continued)
Bus protocol:	Modbus (RTU mode), address range 0... <b>247</b> selectable	
Signal filtering:	4 s / 32 s	
Ambient temperature:	-10...+60 °C	
Response time:	< 2 minutes	
Electrical connection:	0.2-1.5 mm <sup>2</sup> , via push-in terminal	
Housing:	plastic, UV-resistant, material polyamide, 30% glass-globe reinforced, with quick-locking screws (slotted / Phillips head combination), colour traffic white (similar to RAL 9016), housing cover for display is transparent!	
Housing dimensions:	126 x 90 x 50 mm (Tyr2)	
Cable connection:	<b>cable gland</b> , plastic (M 16 x 1.5; with strain relief, exchangeable, inner diameter 10.4 mm) or <b>M12 connector</b> according to DIN EN 61076-2-101 (optional on request)	
Protective tube:	<b>stainless steel V2A</b> (1.4301), Ø 16 mm, NL = 55 mm	
Process connection:	by screws	
Protection class:	III (according to EN 60 730)	
Protection type:	<b>IP 65</b> (according to EN 60 529)	
Standards:	CE conformity, electromagnetic compatibility according to EN 61 326, EMC Directive 2014/30/EU	
Optional:	<b>Display with illumination</b> , three-line, cutout approx. 70 x 40 mm (W x H), for displaying actual humidity, actual temperature, air quality and the actual CO2 content (cyclic) or a selectable parameter (static) or an individually programmable display value (The Modbus interface allows the display to be individually configured in the 7-segment area and in the dot-matrix area.)	
<b>ACCESSORIES</b>	see table	

**AERASGARD® AC02 / ALQ - CO2 - Modbus**  
**AERASGARD® AFTM - (LQ) - CO2 - Modbus**



S+S REGELTECHNIK

Multifunctional on-wall sensors and measuring transducers,  
 for humidity, temperature, CO2 content and air quality (VOC),  
 calibratable, with Modbus connection

Dimensional drawing

AC02-Modbus  
 ALQ - CO2-Modbus

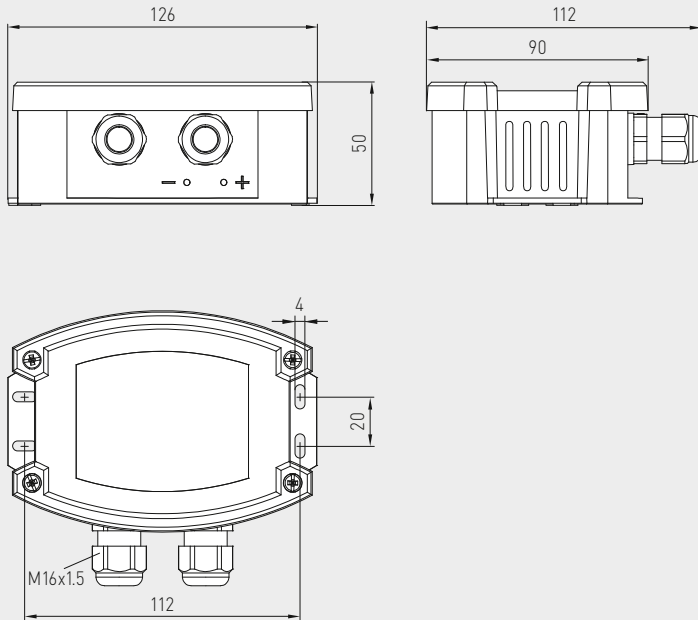

AC02-Modbus  
 ALQ - CO2-Modbus



Dimensional drawing

AFTM - LQ - CO2 - Modbus  
 AFTM - CO2 - Modbus

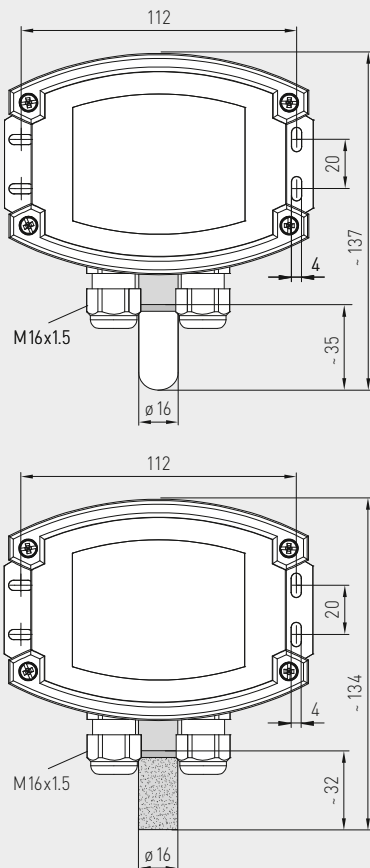

**SF-K**  
 plastic sinter filter  
 (standard)



**SF-M**  
 metal sinter filter  
 (optional)



AFTM - LQ - CO2 - Modbus  
 AFTM - CO2 - Modbus  
 with metal sinter filter  
 (optional)





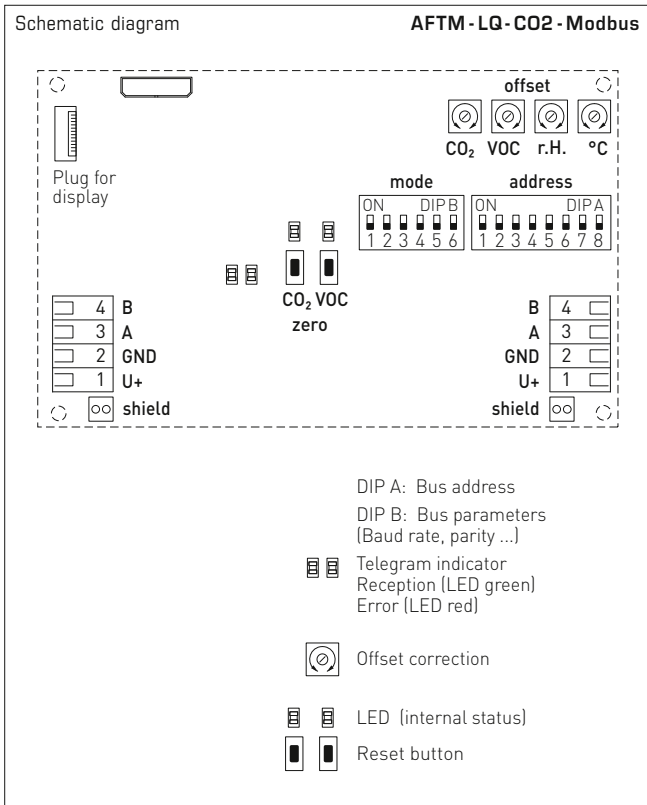

**AFTM - LQ - CO2 - Modbus**  
 with display



<b>AERASGARD® AC02 - Modbus</b>	On-wall sensor for CO <sub>2</sub> content, <i>Deluxe</i>
<b>AERASGARD® ALQ - CO2 - Modbus</b>	On-wall sensor for CO <sub>2</sub> content and air quality (VOC), <i>Deluxe</i>
<b>AERASGARD® AFTM - CO2 - Modbus</b>	Multifunctional on-wall sensor for humidity, temperature and CO <sub>2</sub> content, <i>Deluxe</i>
<b>AERASGARD® AFTM - LQ - CO2 - Modbus</b>	Multifunctional on-wall sensor for humidity, temperature, CO <sub>2</sub> content and air quality (VOC), <i>Deluxe</i>

Type / WG02	Measuring Range	Humidity	Temperature	CO <sub>2</sub>	VOC	Display	Item No.	Price
<b>AC02-Modbus</b>								
AC02-Modbus	–	–	–	5000 ppm	–		1501-7110-6001-200	<b>357,53 €</b>
AC02-Modbus LCD	–	–	–	5000 ppm	–	■	1501-7110-6071-200	<b>425,91 €</b>
<b>ALQ - CO2 - Modbus</b>								
ALQ-CO2-Modbus	–	–	–	5000 ppm	0..100%		1501-7111-6001-500	<b>481,92 €</b>
ALQ-CO2-Modbus LCD	–	–	–	5000 ppm	0..100%	■	1501-7111-6071-500	<b>563,68 €</b>
<b>AFTM - CO2 - Modbus</b>								
AFTM-CO2-Modbus	0..100% r.H.	–35...+80 °C	–	5000 ppm	–		1501-7116-6001-200	<b>448,51 €</b>
AFTM-CO2-Modbus LCD	0..100% r.H.	–35...+80 °C	–	5000 ppm	–	■	1501-7116-6071-200	<b>537,20 €</b>
<b>AFTM - LQ - CO2 - Modbus</b>								
AFTM-LQ-CO2-Modbus	0..100% r.H.	–35...+80 °C	–	5000 ppm	0..100%		1501-7118-6001-500	<b>573,15 €</b>
AFTM-LQ-CO2-Modbus LCD	0..100% r.H.	–35...+80 °C	–	5000 ppm	0..100%	■	1501-7118-6071-500	<b>677,71 €</b>
Note:	This unit <b>must not</b> be used as safety-relevant device!							
Optional:	Cable connection with <b>M12 connector</b> according to DIN EN 61076-2-101						on request	
<b>ACCESSORIES</b>								
<b>KA2-Modbus</b>	<b>Communication adapter</b> (USB/RS485) for system connection						1906-1200-0000-100	<b>203,80 €</b>
<b>LA-Modbus</b>	<b>Line termination device</b> (with terminating resistor) as an active bus termination						1906-1300-0000-100	<b>76,01 €</b>
<b>SF-M</b>	<b>Metal sinter filter</b> , Ø 16 mm, L = 32 mm, exchangeable/stainless steel <b>V4A</b> (1.4404)						7000-0050-2200-100	<b>40,31 €</b>
<b>WS-03</b>	<b>Weather and sun protection hood</b> , 200 x 180 x 150 mm, stainless steel <b>V2A</b> (1.4301)						7100-0040-6000-000	<b>42,61 €</b>
For further information see last chapter!								

# AERASGARD® **KCO2 / KLQ - CO2 - Modbus** **AERASGARD® **KFTM - (LQ) - CO2 - Modbus****



S+S REGELTECHNIK

**Multifunctional duct sensors and measuring transducers incl. mounting flange, for humidity, temperature, CO2 content and air quality (VOC), calibratable, with Modbus connection**

## Patented quality product (patent no. DE 10 2014 010 719.1)

The maintenance-free, microprocessor-controlled **AERASGARD® AFTM - LQ - CO2 - Modbus** and **KCO2 / KLQ - CO2 / KFTM - CO2 - Modbus** with Modbus connection, with /without optional display, is designed for duct installation and is used to monitor all measurands of relevance to the climate inside a room. These are the measurands air humidity, temperature, CO2 concentration as well as air quality (VOC). By using a single device to monitor all four measurands, it is possible to effectively monitor and regulate the entire room climate. It measures CO2 in the range of 0...5000 ppm, VOC at one of three selectable sensitivity levels LOW / MEDIUM / HIGH, temperatures in the range of -35...+80 °C, as well as relative air humidity from 0...100 % r.H.

A digital, long-term stable sensor used as measuring element for relative air humidity and temperature guarantees exact measurement results. The Modbus can be used to retrieve the following parameters: Temperature [°C], relative humidity [% r.H.], air quality (VOC) [%], carbon dioxide (CO2) [ppm] and atmospheric pressure [hPa].

The CO2 content of the air is measured using an optical NDIR sensor (non-dispersive infra-red technology). The detection range of the sensors is calibrated for standard applications such as monitoring residential rooms and conference rooms. Room ventilation on an as-needed basis, improved well-being and customer benefit, increased comfort as well as reduced operating costs through energy conservation are just some of the benefits of employing the AERASGARD® CO2 sensor. One sensor for every 30m² of room area is recommended.

The explanations above demonstrate that there are applications for CO2 measurements, for VOC measurements, but from our perspective, above all, for a combination of both measurands. The crucial factor in this respect is that both of these measurands are not convertible into each other and derivations to or from one another cannot be made. An NDIR CO2 measuring instrument measures selectively and cannot detect any VOC; a VOC mixed gas sensor cannot recognize CO2 molecules.

### TECHNICAL DATA

Voltage supply:	24 V AC / DC (± 10 %)
Power consumption:	< 4.8 W / 24 V DC typical; < 6.8 VA / 24 V AC typical; peak current 200 mA
Data points:	Temperature [°C], relative humidity [% r.H.], air quality (VOC) [%], carbon dioxide (CO2) [ppm], atmospheric pressure [hPa]

### HUMIDITY

Sensors:	<b>digital humidity sensor with integrated temperature sensor, low hysteresis, high long-term stability</b>
Sensor protection:	<b>plastic sinter filter, Ø 16 mm, L = 35 mm, exchangeable</b> (optional <b>metal sinter filter, Ø 16 mm, L = 32 mm</b> )
Measuring range, humidity:	0...100 % r. H.
Operating range, humidity:	0...95 % r. H. (without dew formation)
Deviation of humidity:	typically <b>± 2.0 %</b> (20...80 % r. H.) at +25 °C, otherwise <b>± 3.0 %</b>

### TEMPERATURE

Measuring range, temperature:	-35...+80 °C
Operating range, temperature:	-10...+60 °C
Deviation, temperature:	typically <b>± 0.2 K</b> at 25 °C

### AIR QUALITY (VOC)

Sensor, VOC:	VOC sensor (metal oxide) <b>with automatic calibration</b> (VOC = volatile organic compounds)
Measuring range, VOC:	0...100 % air quality; referred to calibrating gas; <b>multi-range switching</b> VOC sensitivity low, medium, high
Measuring accuracy, VOC:	± 20 % of final value (referred to calibrating gas)
Service life:	> 60 months (under normal load conditions)

### CARBON DIOXIDE (CO2)

Sensor, CO2:	optical NDIR sensor (non-dispersive infra-red technology) including atmospheric pressure compensation (up to 1100 mbar) <b>with automatic and manual calibration</b>
Measuring range, CO2:	0...5000 ppm
Measuring accuracy, CO2:	typically <b>± 30 ppm ± 3 %</b> of measured value
Temperature dependence, CO2:	± 5 ppm / °C or <b>± 0.5 %</b> of measured value / °C (whichever is higher)
Pressure dependence:	± 0.13 % / mm Hg
Long-term stability:	< 2 % in 15 years
Gas exchange:	by diffusion

(continued on next page!)

Display screen (cyclic) Modbus Tyr 2

Temperature

Humidity

Air quality (VOC)

Carbon dioxide (CO2)

Display screen (static) Modbus Tyr 2

Carbon dioxide (CO2)

Atmospheric pressure

Programmable display screen Modbus Tyr 2



S+S REGELTECHNIK

# AERASGARD® KC02 / KLQ - CO2 - Modbus AERASGARD® KFTM - (LQ) - CO2 - Modbus

Multifunctional duct sensors and measuring transducers incl. mounting flange, for humidity, temperature, CO2 content and air quality (VOC), calibratable, with Modbus connection

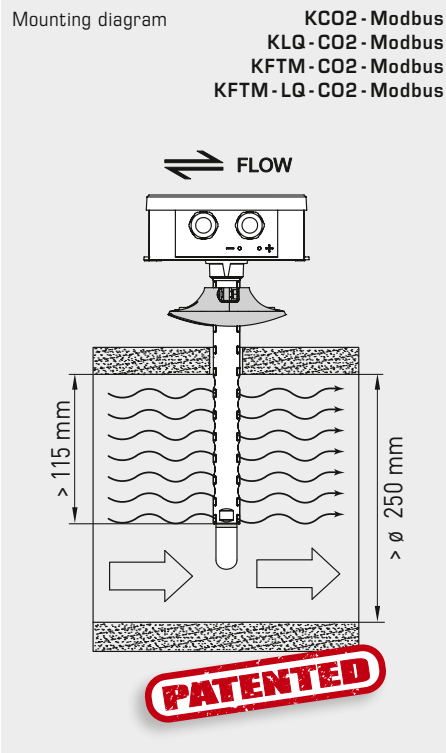

**MFT-20-K**  
Mounting flange,  
plastic



**KFTM - CO2 - Modbus  
KFTM - LQ - CO2 - Modbus**  
with plastic sinter filter  
(standard)



**KFTM - CO2 - Modbus  
KFTM - LQ - CO2 - Modbus**  
with display and  
plastic sinter filter  
(standard)



**SF-K**  
Plastic sinter filter  
(standard)



**SF-M**  
Metal sinter filter  
(optional)

TECHNICAL DATA		(continued)
Bus protocol:	Modbus (RTU mode), address range 0... <b>247</b> selectable	
Signal filtering:	4 s / 32 s	
Ambient temperature:	-10...+60 °C	
Response time:	< 2 minutes, minimal flow velocity 0.3 m/s (air)	
Electrical connection:	0.2 - 1.5 mm <sup>2</sup> , ia push-in terminal	
Housing:	plastic, UV-resistant, material polyamide, 30% glass-globe reinforced, with quick-locking screws (slotted / Phillips head combination), colour traffic white (similar to RAL 9016), housing cover for display is transparent!	
Housing dimensions:	126 x 90 x 50 mm (Tyr 2)	
Cable connection:	<b>cable gland</b> , plastic (M 16 x 1.5; with strain relief, exchangeable, inner diameter 10.4 mm) <b>or</b> <b>M12 connector</b> according to DIN EN 61076-2-101 (optional on request)	
Protective tube:	<b>PLEUROFORM™</b> , material polyamide (PA6), with torsion protection, Ø 20 mm, v <sub>max</sub> = 30 m/s (air) without filter: NL = 202.5 mm / with plastic filter: NL = 235 mm (optional with metal filter: NL = 227 mm)	
Process connection:	via mounting flange made of plastic (included in scope of delivery)	
Protection class:	III (according to EN 60730)	
Protection type:	<b>IP 65</b> (according to EN 60529) housing in the built-in state (permeable PLEUROFORM: IP30)	
Standards:	CE conformity, electromagnetic compatibility according to EN 61326, EMC Directive 2014/30/EU	
Optional:	<b>Display with illumination</b> , three-line, cutout approx. 70 x 40 mm (W x H), for displaying actual humidity, actual temperature, air quality and the actual CO2 content (cyclic) or a selectable parameter (static) or an individually programmable display value (The Modbus interface allows the display to be individually configured in the 7-segment area and in the dot-matrix area.)	
<b>ACCESSORIES</b>	see table	

**AERASGARD® KCO2 / KLQ - CO2 - Modbus**  
**AERASGARD® KFTM - (LQ) - CO2 - Modbus**



S+S REGELTECHNIK

Multifunctional duct sensors and measuring transducers incl. mounting flange,  
 for humidity, temperature, CO2 content and air quality (VOC),  
 calibratable, with Modbus connection

Dimensional drawing

**KCO2-Modbus**  
**KLQ - CO2-Modbus**

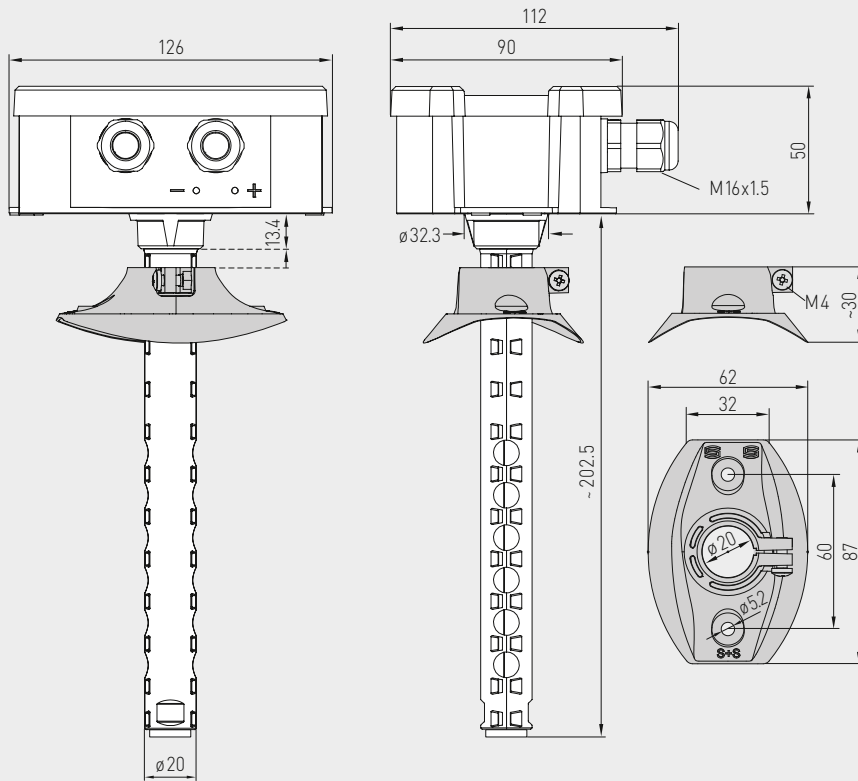

**KCO2-Modbus**  
**KLQ - CO2-Modbus**



Dimensional drawing

**KFTM - CO2 - Modbus**  
**KFTM - LQ - CO2 - Modbus**

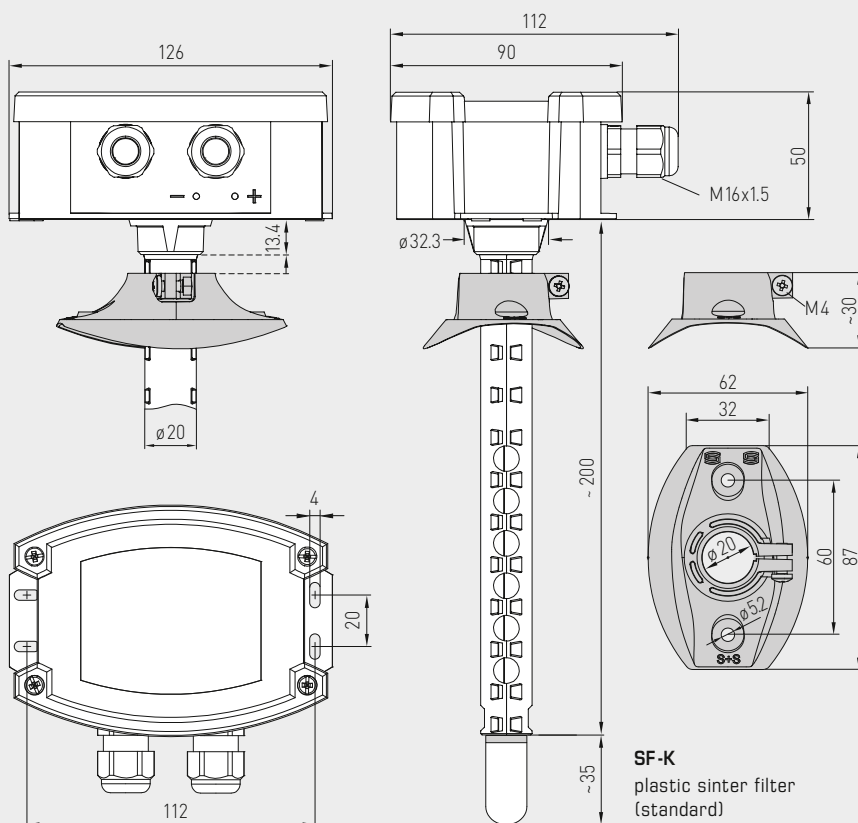

**KFTM - CO2 - Modbus**  
**KFTM - LQ - CO2 - Modbus**



**SF-M**  
 metal sinter filter  
 (optional)



**SF-K**  
 plastic sinter filter  
 (standard)



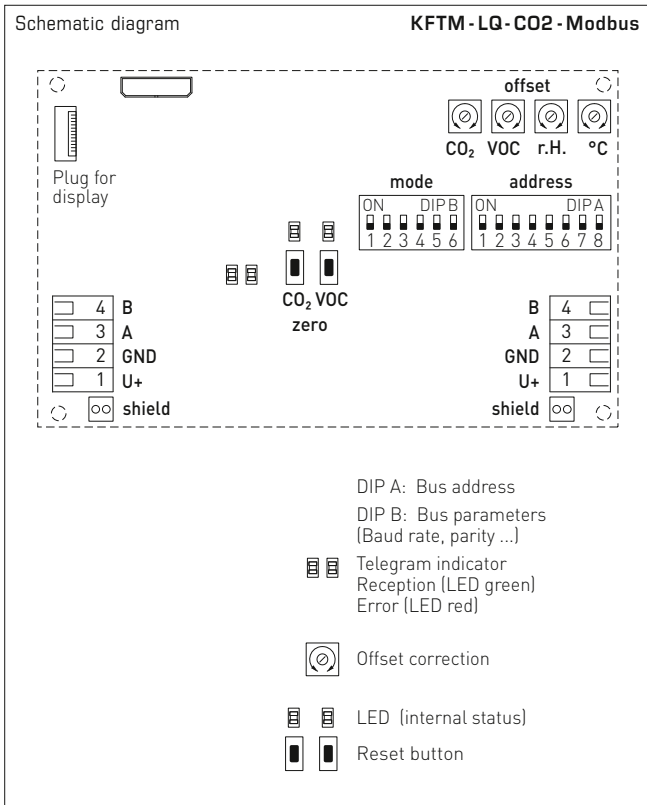

**KFTM - LQ - CO2 - Modbus**  
 with display



<b>AERASGARD® KCO2 - Modbus</b>	Duct sensor for CO <sub>2</sub> content, <i>Deluxe</i>
<b>AERASGARD® KLQ - CO2 - Modbus</b>	Duct sensor for air quality (VOC) and CO <sub>2</sub> content, <i>Deluxe</i>
<b>AERASGARD® KFTM - CO2 - Modbus</b>	Multifunctional duct sensor for humidity, temperature and CO <sub>2</sub> content, <i>Deluxe</i>
<b>AERASGARD® KFTM - LQ - CO2 - Modbus</b>	Multifunctional duct sensor for humidity, temperature, air quality (VOC) and CO <sub>2</sub> content, <i>Deluxe</i>

Type / WG02	Measuring Range				Display	Item No.	Price
	Humidity	Temperature	CO <sub>2</sub>	VOC			
<b>KCO2-Modbus</b>							
KCO2-Modbus	–	–	5000 ppm	–		1501-8110-6001-200	<b>357,53 €</b>
KCO2-Modbus <b>LCD</b>	–	–	5000 ppm	–	■	1501-8110-6071-200	<b>414,89 €</b>
<b>KLQ - CO2-Modbus</b>							
KLQ-CO2-Modbus	–	–	5000 ppm	0...100%		1501-8111-6001-500	<b>403,61 €</b>
KLQ-CO2-Modbus <b>LCD</b>	–	–	5000 ppm	0...100%	■	1501-8111-6071-500	<b>471,55 €</b>
<b>KFTM - CO2-Modbus</b>							
KFTM-CO2-Modbus	0...100% r.H.	–35...+80 °C	5000 ppm	–		1501-8116-6001-200	<b>366,75 €</b>
KFTM-CO2-Modbus <b>LCD</b>	0...100% r.H.	–35...+80 °C	5000 ppm	–	■	1501-8116-6071-200	<b>447,37 €</b>
<b>KFTM - LQ - CO2-Modbus</b>							
KFTM-LQ-CO2-Modbus	0...100% r.H.	–35...+80 °C	5000 ppm	0...100%		1501-8118-6001-500	<b>479,62 €</b>
KFTM-LQ-CO2-Modbus <b>LCD</b>	0...100% r.H.	–35...+80 °C	5000 ppm	0...100%	■	1501-8118-6071-500	<b>563,68 €</b>
Note:	This unit <b>must not</b> be used as safety-relevant device!						
Optional:	Cable connection with <b>M12 connector</b> according to DIN EN 61076-2-101					on request	
<b>ACCESSORIES</b>							
<b>KA2-Modbus</b>	<b>Communication adapter</b> (USB/RS485) for system connection					1906-1200-0000-100	<b>203,80 €</b>
<b>LA-Modbus</b>	<b>Line termination device</b> (with terminating resistor) as an active bus termination					1906-1300-0000-100	<b>76,01 €</b>
<b>SF-M</b>	<b>Metal sinter filter</b> , Ø 16 mm, L = 32 mm, exchangeable, stainless steel <b>V4A</b> (1.4404)					7000-0050-2200-100	<b>40,31 €</b>
<b>MFT-20-K</b>	<b>Mounting flange</b> , plastic (included in the scope of delivery)					7000-0031-0000-000	<b>9,10 €</b>
For further information, see last chapter Accessories!							

**Line termination device with terminating resistor  
for the active bus termination of RS485 networks**

LA-Modbus

Line termination device **MODKON® LA-Modbus T3** with terminating resistor, in an impact-resistant plastic housing with quick-locking screws.

The line termination serves as an active bus termination for RS485 networks (ANSI TIA/EIA-485), such as Modbus RTU. It contains a terminating resistor with a biasing network, which pre-defines the bus signals to a safe value (fail-safe biasing) during bus idle time.

The bus termination can be fully switched on or off via DIP switches. This allows various operating scenarios to be tested in a simple manner whenever servicing is needed.

For very long network cables, both end points can also be provided with an active bus termination to improve interference immunity under harsh environmental conditions.



**TECHNICAL DATA**

Power supply:	24 V AC (±20%) and 15...36 V DC
Power consumption:	< 0.5 W / 24 V DC; < 0.5 VA / 24 V AC
Housing:	Plastic, UV-resistant, polyamide material, 30% glass-globe reinforced, with quick-locking screws (slotted / Phillips head combination), colour traffic white (similar to RAL 9016)
Housing dimensions:	108 x 78.5 x 43.3 mm (Tyr 3 without display)
Cable connection:	Cable gland, plastic (2x M20 x 1.5; with strain relief, exchangeable, inner diameter 8 - 13 mm)
Electrical connection:	0.2 - 1.5 mm <sup>2</sup> , using push-in terminals
Ambient temperature:	-30...+70 °C
Permitted humidity:	< 95 % r. H., non-precipitating air
Protection class:	III (according to EN 60 730)
Protection type:	<b>IP65</b> (according to EN 60 529)
Operation display:	Status LED <b>PWR ON</b> (supply voltage)
Standards:	CE conformity, electromagnetic compatibility according to EN 61326, according to EMC Directive 2014 / 30 / EU

DIP 1	DIP 2	Resistance (type adjustable)	Bus termination (explanation)
ON	ON	<b>R<sub>AB</sub> active</b> and <b>R<sub>BIAS</sub> active</b>	Line termination and BIAS active
ON	OFF	<b>R<sub>AB</sub> active</b>	Line termination active
OFF	OFF	<b>Deactivated</b>	Bus termination switched off

Connecting diagram

LA-Modbus

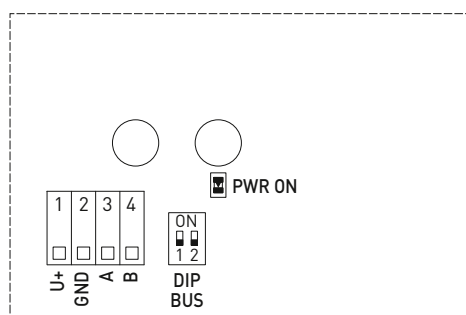

- Push-in terminal**
- +UB** Terminal 1: +UB 24V
- GND** Terminal 2: -UB GND
- A/B** Terminal 3/4: RS485 Modbus
- Status LED**
- PWR ON** Supply voltage
- DIP switch**
- DIP BUS** Activation or deactivation of the bus termination

Dimensional drawing

LA-Modbus

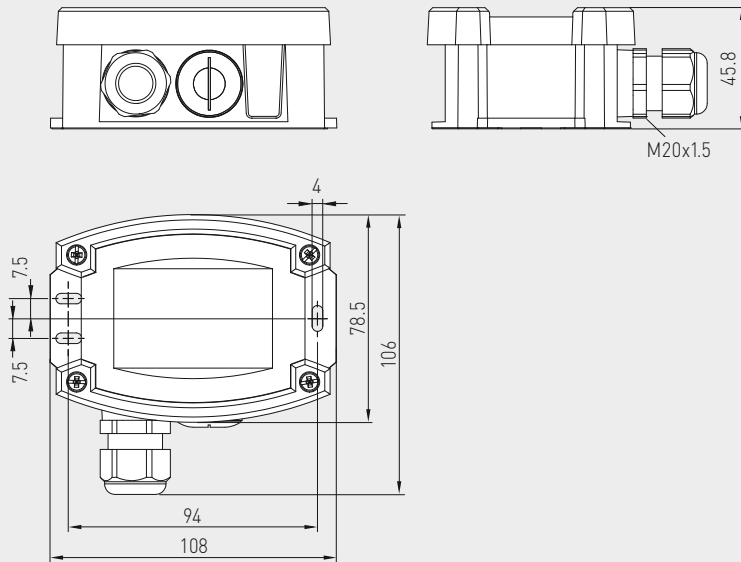

LA-Modbus



Bus topology with terminating and bias resistors

LA-Modbus

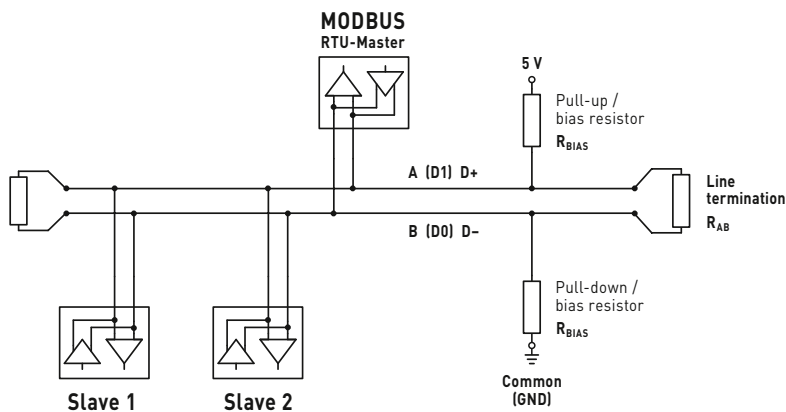

**MODKON® LA-Modbus** Line termination device with terminating resistor

Type / WG01	Bus termination (adjustable)	Item No.	Price
LA-Modbus			
LA-Modbus	1. Line termination and BIAS active 2. Line termination active 3. Bus termination deactivated	1906-1300-0000-100	76,01 €

**Note:** The bus termination can be fully switched on or off (via DIP switches).

Communication adapter incl. software MODKON RTU,  
with USB and RS485 interface,  
for system connection of S+S Modbus sensors

KA2-Modbus

Communication adapter **MODKON® KA2-Modbus T3** with USB and RS485 interface, in an impact-resistant plastic housing with quick-locking screws, incl. software.

The communication adapter serves as connecting element between an S+S Modbus sensor and a PC (Windows). A standard USB port enables quick and straightforward connection to the system; there is no need for an additional power supply.

When used in combination with the S+S software **MODKON RTU** (included in delivery), it offers a very convenient way to test the response behaviour of the sensor.

The Auto Scan function of the software automatically detects the device type, the device address and the set bus parameters. In this way, communication with the connected S+S Modbus sensor is possible without the need for additional settings. The ideal first step to gain experience with Modbus technology.



**TECHNICAL DATA**

Power supply:	Takes place via USB connection
Output:	Voltage: 15 V; Current: 100 mA
Interfaces:	Standard <b>USB</b> port for system connection, power supply <b>RS485</b> interface for connection of an S+S Modbus sensor
Compatibility:	S+S Modbus sensors for the device classes <b>THERMASGARD®</b> , <b>HYGRASGARD®</b> , <b>PREMASGARD®</b> , <b>AERASGARD®</b>
Housing:	Plastic, UV-resistant, polyamide material, 30% glass-globe reinforced, with quick-locking screws (slotted / Phillips head combination), colour traffic white (similar to RAL 9016)
Housing dimensions:	108 x 78.5 x 45.8 mm (Tyr 3)
Cable connection:	Cable gland, plastic (2x M 20 x 1.5; with strain relief, exchangeable, inner diameter 8 - 13 mm)
Electrical connection:	0.2 - 1.5 mm <sup>2</sup> , using push-in terminals
Ambient temperature:	-30...+70 °C
Permitted humidity:	< 95% r. H., non-precipitating air
Protection class:	III (according to EN 60 730)
Protection type:	<b>IP 54</b> (according to EN 60 529) housing only!
Standards:	CE conformity, electromagnetic compatibility according to EN 61326, according to EMC Directive 2014 / 30 / EU

Mounting diagram

KA2-Modbus

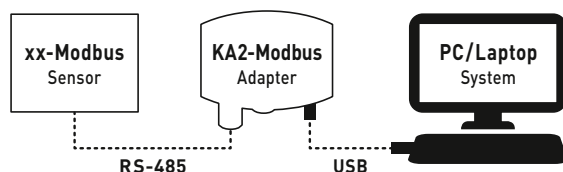

Connecting diagram

KA2-Modbus

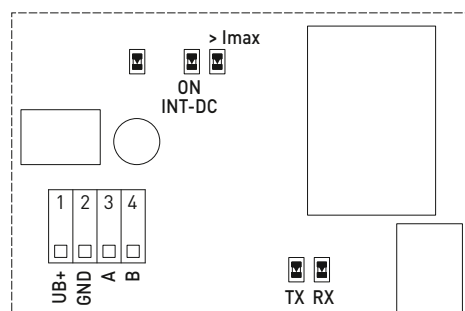

- Push-in terminal**
- +UB** Output supply for S+S Modbus sensor
  - GND** approx. 15V (max. 100mA) with supply via USB
  - A/B** RS485 Modbus
- Status LEDs**
- >Imax** Electronic fuse approx. 150mA
  - INT-DC** Internal supply (USB)
  - TX** Transmit telegrams
  - RX** Receive telegrams





S+S REGELTECHNIK

Communication adapter incl. software MODKON RTU,  
with USB and RS485 interface,  
for system connection of S+S Modbus sensors

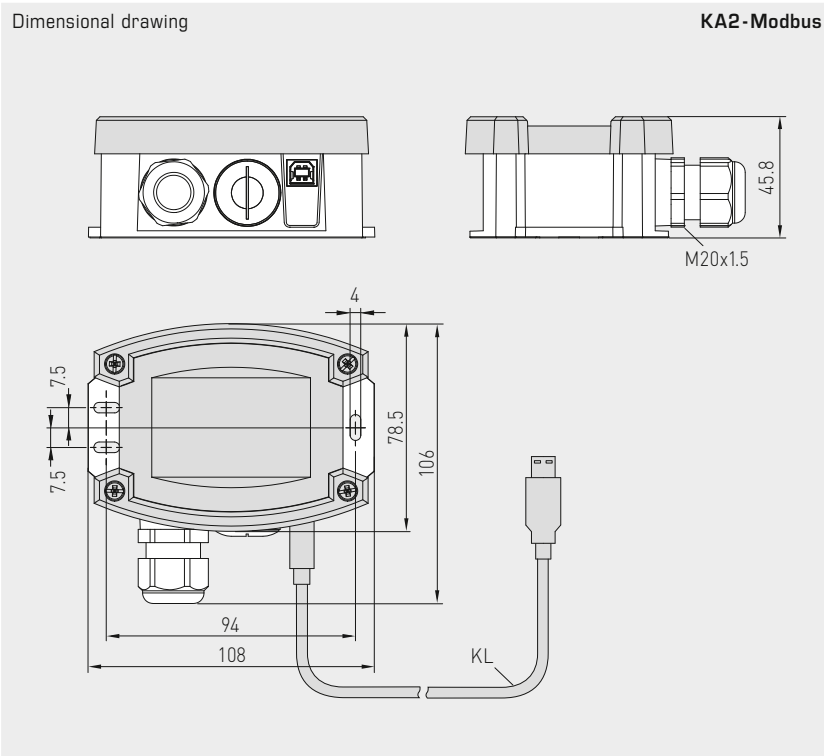

KA2-Modbus

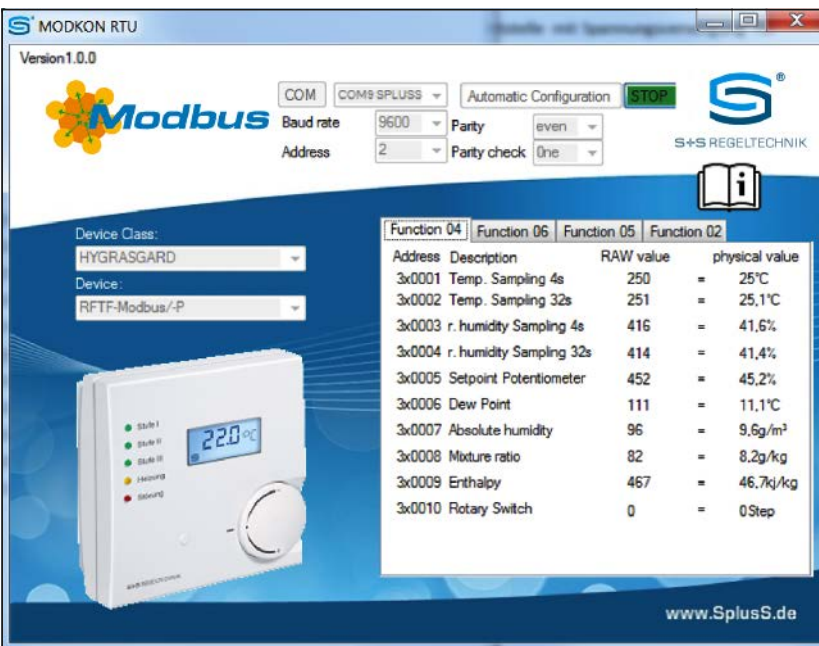

Fig. shows the input screen of the S+S software MODKON RTU (included in the scope of delivery) based on the example of the S+S Modbus sensor HYGRASGARD® RFTF-Modbus

MODKON® KA2-Modbus Communication adapter incl. software				
Type / WG01	Interfaces	Software	Item No.	Price
KA2-Modbus	USB + RS485	MODKON RTU	1906-1200-0000-100	203,80 €

**Note:** You can find information on how to operate the software on the USB stick included or in the online shop.



## Temperature PASSIVE SENSORS

Our passive **THERMASGARD®** temperature sensors have a proven fit in countless applications across all areas of temperature measurement. Technology for best measuring results you can rely on. Available in various different models and individual versions to meet your precise requirements.

### APPLICATION RANGE

- > Hospitals, museums, schools, hotels and administration buildings
- > Power plants and district heating facilities
- > Pharmaceutical and food industry
- > Production plants
- > Heating systems

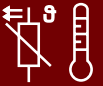

## THERMASGARD®

162 – 249

### Room sensors

<b>DTF</b>	In-ceiling temperature sensor	<b>185</b>
<b>RTF</b>	Room temperature sensor, on-wall	<b>166</b>
<b>RTF 1</b>	Room temperature sensor, on-wall	<b>168</b>
<b>FSTF</b>	Room temperature sensor, in-wall	<b>178</b>
<b>FSTF 1</b>	Room temperature sensor, in-wall	<b>179</b>
<b>RPTF 1</b>	Pendulum room temperature sensor	<b>246</b>
<b>RPTF 2</b>	Pendulum room temperature sensor	<b>247</b>
<b>RSTF</b>	Room radiation temperature sensor	<b>249</b>
<b>RTF-xx</b>	Room control units, on-wall	<b>171</b>
<b>FSTF-xx</b>	Room control units, in-wall	<b>180</b>

### Outdoor sensor, on-wall sensor

<b>ATF01</b>	Outside temperature sensor	<b>186</b>
<b>ATF 1</b>	Outside temperature sensor	<b>187</b>
<b>ATF2</b>	Outside temperature sensor	<b>189</b>
<b>ASTF</b>	On-wall radiation temperature sensor	<b>248</b>

### Duct sensors, surface-contact sensors

<b>HTF</b>	Sleeve temperature sensor with cable	<b>236</b>
<b>OFTF</b>	Surface temperature sensor	<b>241</b>
<b>ALTF 1</b>	Surface-contact temperature sensor with cable	<b>242</b>
<b>ALTF02</b>	Surface-contact temperature sensor	<b>244</b>
<b>ALTF2</b>	Surface-contact temperature sensor	<b>245</b>

### Duct, immersion, screw-in sensors

<b>TF43</b>	Duct / immersion / screw-in sensor	<b>194</b>
<b>TF65</b>	Duct / immersion / screw-in sensor	<b>192</b>
<b>TF54</b>	Duct / immersion / screw-in sensor	<b>210</b>
<b>TF43-F</b>	Duct / immersion / screw-in sensor with cable	<b>199</b>
<b>TF65-F</b>	Duct / immersion / screw-in sensor with cable	<b>199</b>
<b>MWTF</b>	Mean-value temperature sensor	<b>205</b>
<b>MWTF-SD</b>	Mean-value temperature sensor	<b>205</b>
<b>ETF6</b>	Screw-in sensor with neck tube	<b>218</b>
<b>ETF7</b>	Screw-in sensor, fast-acting	<b>207</b>
<b>RGTF 2</b>	Smoke gas screw-in sensor	<b>231</b>
<b>RGTF 1</b>	Smoke gas duct sensor	<b>225</b>
<b>HTF</b>	Duct / immersion / screw-in sensor with cable	<b>238</b>

### Immersion sleeves and accessories

see chapter Accessories	<b>636</b>
-------------------------	------------





# Temperature



## THERMASGARD® & THERMASREG® Sensor technology for heat and cold

### Broad Spectrum

Our temperature measuring transmitters are available customised to your requirements. Thanks to microprocessor technology, almost any measuring range can be represented, including custom specifications. Multi-range switching is selectable via DIP switches.

### Optimum Precision

The devices are calibrated in-house in climate cabinets and are tested according to the latest criteria. Each sensor is precisely re-adjustable using offset potentiometers. Take advantage of our experience, our development, manufacturing and product know-how and order these products directly from the manufacturer.

### Approved Safety

The **THERMASGARD® 1101-I** with current output (Test No. 69871-01939-1) and the **THERMASGARD® 1101-U** with voltage output (Test No. 69871-01940-1) are tested and certified according to DIN EN 61326-1:2006 and EN 61326-2-3:2006 by TÜV SÜD.

**THERMASREG® ETR** and **KTR** are tested and certified to DIN EN 14597:2015-01.



DIN tested/certified devices



RoHS conforming materials



ESD compliant manufacturing



CE compliance tested by external laboratories

### Certified Quality



Our development and production in Nuremberg/Germany is certified by TÜV Thüringen according to DIN EN ISO 9001:2015.



GOST certificates



EAC certified



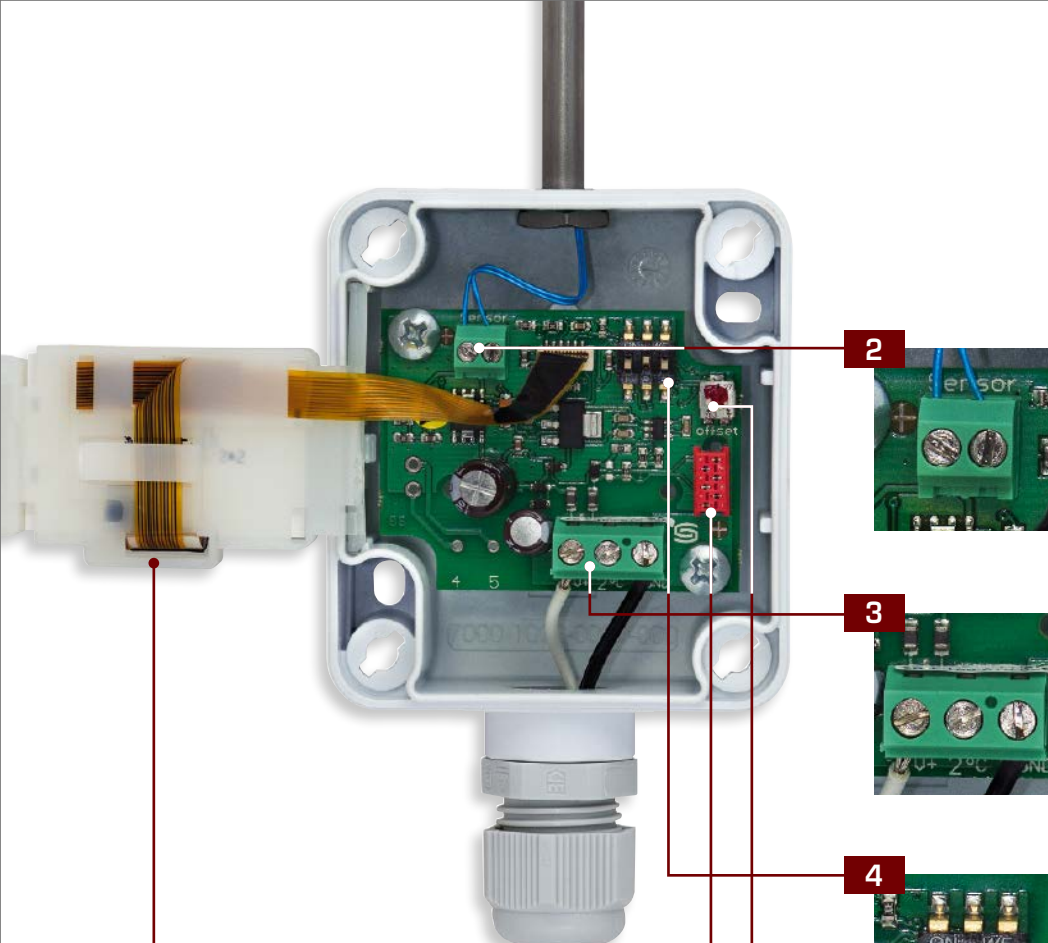

**Illuminated Display**

With backlighting as well as display of range violation, sensor breakage, sensor short circuit and physical units

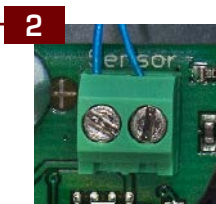

**Sensors**

Internal sensors / external sensors



**Screw Terminals**

Active output signals 0-10 V, 4...20 mA or switched as well as passive outputs (e.g. Pt1000, Ni1000 etc.)

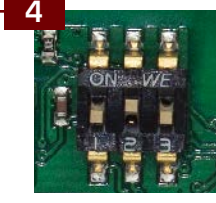

**DIP Switches**

For multi-range toggling and setting of measuring ranges

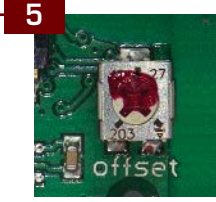

**Offset Potentiometer**

For fine adjustment (zero point offset) and readjustment upon recalibration

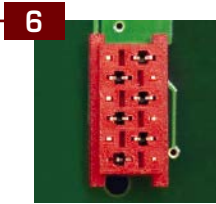

**Quality Assurance**

Calibration and balancing are done by means of the bus system in climate cabinets



Configuration variants of room operating units

Room temperature sensors and measuring transducers, on-wall, device series Baldur

Housing temperature sensors are electric contact thermometers for measuring temperatures in the gases (air) surrounding them on all sides. Room temperature sensors/measuring transducers are used for measuring air temperature (in non-precipitating air), for changing setpoint values, for presence detection, or as operating panels with push-buttons, switches, potentiometers, status indicators (LEDs) in residential, working, office and business facilities as well as in the industrial sector.

Here are some design and configuration examples of variants of the new Baldur series devices that can be individually customized ...

DEVICE SERIES

- Baldur 1 (85 x 85 x 27 mm)
- Baldur 2 (98 x 98 x 33 mm)

Baldur lying



Baldur 1 without operating elements



Baldur 1 with display



Baldur 1 with display and potentiometer



Baldur 1 with potentiometer, push-button, and LED



Baldur 1 with potentiometer and rocker switch



Baldur 1 with potentiometer and push-buttons



Baldur 1 with potentiometer and LEDs



Baldur 1 with potentiometer and LEDs



Baldur 1 with potentiometer and LEDs





**Baldur 2**  
without operating elements



**Baldur 2**  
with display



**Baldur 2** with display,  
potentiometer, and LEDs



**Baldur 2**  
with LEDs and push-buttons



**Baldur 2**  
with LEDs and push-buttons



**Baldur 2** with potentiometer,  
turn switch, and LEDs



**Baldur 2** with potentiometer,  
turn switch, and LEDs



**Baldur 2** with potentiometer,  
push-buttons, LEDs, and rocker switch



**Baldur 2** with potentiometer,  
turn switch, and LEDs



**Baldur 2** with potentiometer  
and turn switch



**Baldur 2** with potentiometer,  
turn switch, LEDs, and push-buttons



**Baldur 2** with potentiometer,  
turn switch, LEDs, and push-buttons



Room temperature sensors and measuring transducers, on-wall

Room temperature sensor **THERMASGARD® RTF 1** with passive output, in an elegant housing made of plastic, with snap-on lid, base with 4-hole attachment for installation on vertically or horizontally installed in-wall flush boxes, with predetermined breaking point for on-wall cable entry, or in enclosures made of stainless steel (top and bottom part are of stainless steel, the lid is screwed on), vandal-proof version e.g. for schools, military barracks, and public buildings. This residential room temperature sensor is used to detect/display temperatures in closed dry rooms, in apartments, in cinemas, supermarkets, storage rooms, office and business facilities.

**TECHNICAL DATA**

Measuring range:	-30...+70 °C
Sensor / output:	see table, passive
Connection type:	2-wire connection (4-wire connection on PT100/PT1000A, optional on other sensors)
Testing current:	< 0.6 mA (Pt1000) < 1.0 mA (Pt100) < 0.3 mA (Ni1000, Ni1000 TK5000) < 2.0 mW (NTC xx) 400 µA...5 mA (LM235Z)
Process connection:	by screws
Housing:	plastic, material ABS, colour pure white (similar to RAL 9010), optional stainless steel <b>V2A</b> (1.4301)
Dimensions:	85 x 85 x 27 mm (Baldur 1) Standard 98 x 98 x 33 mm (Baldur 2) optional 75 x 75 x 25 mm (stainless steel <b>V2A</b> (1.4301) optional
Installation:	wall mounting or on in-wall flush box Ø55 mm, base with 4-hole for mounting on vertically or horizontally installed in-wall flush boxes for cable entry from the back, with predetermined breaking point for on-wall cable entry from top/bottom in case of plain on-wall installation
Electrical connection:	0.14 - 1.5 mm <sup>2</sup> via terminal screws, secured against loss due to unscrewing, on safety extra-low voltage max. 24 V DC only
Humidity:	max. 90% r. H., non-precipitating air
Protection class:	III (according to EN 60 730)
Protection type:	IP 30 (according to EN 60 529)
<b>ACCESSORIES</b>	see last chapter

1x two-wire connection standard

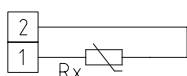

1x two-wire connection LM235Z (KP10)

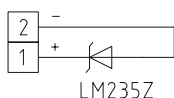

1x four-wire connection (optional)

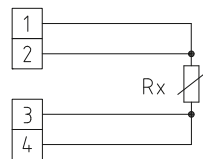

**THERMASGARD® RTF 1** Room temperature sensors (Standard)

Type / WG03	Sensor / Output	Item No.	Price
<b>RTF1 xx</b>	<b>passive</b>	<b>IP 30 (-30...+70 °C)</b>	
RTF1 Pt100	Pt100 (according to DIN EN 60 751, class B)	1101-40A0-1003-000	<b>22,24 €</b>
RTF1 Pt1000	Pt1000 (according to DIN EN 60 751, class B)	1101-40A0-5000-000	<b>24,73 €</b>
RTF1 Pt1000A	Pt1000 (according to VDI/VDE 3512, class A-TGA)	1101-40A0-6003-000	<b>26,43 €</b>
RTF1 Ni1000	Ni1000 (according to DIN EN 43 760, class B, TCR = 6180 ppm/K)	1101-40A0-9000-000	<b>24,39 €</b>
RTF1 NiTK	Ni1000 TK5000 (TCR = 5000 ppm/K), LG-Ni1000	1101-40A1-0000-000	<b>24,39 €</b>
RTF1 LM235Z	LM235Z (TCR = 10 mV/K; 2.73 V at 0 °C), KP10	1101-40A2-1000-000	<b>22,81 €</b>
RTF1 NTC1,8K	NTC 1.8K	1101-40A1-2000-000	<b>20,78 €</b>
RTF1 NTC10K	NTC 10K	1101-40A1-5000-000	<b>20,78 €</b>
RTF1 NTC20K	NTC 20K	1101-40A1-6000-000	<b>20,78 €</b>
Extra charge:	<b>Stainless steel housing optional</b> Other sensors optional		<b>104,46 €</b> on request



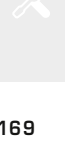
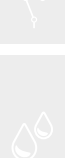

Dimensional drawing

Housing **Baldur 1**  
(only one potentiometer possible)

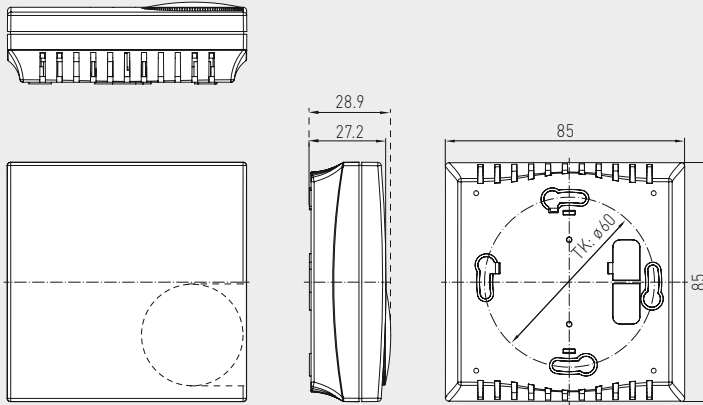

**RTF**  
(Baldur 1)



Dimensional drawing

Housing **Baldur 2**  
(one or two potentiometers possible)

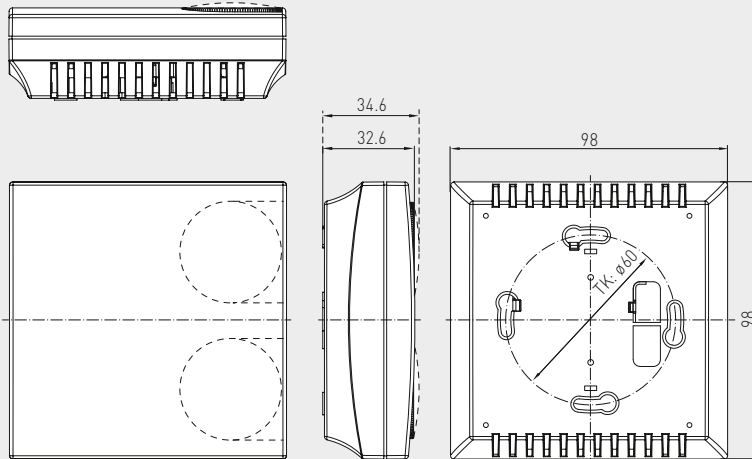

**RTF**  
(Baldur 2)



Dimensional drawing

Housing stainless steel

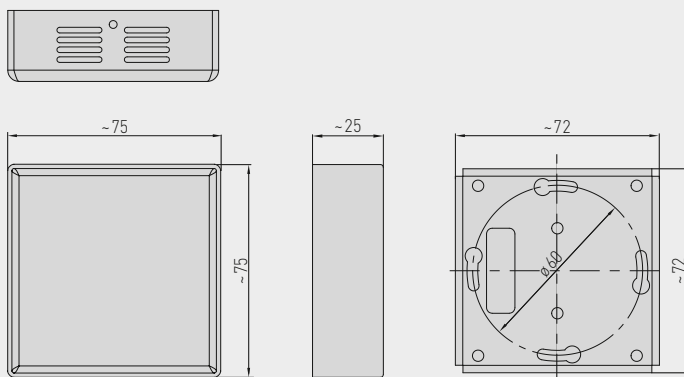

**RTF**  
(stainless steel)



Room temperature sensors and measuring transducers,  
on-wall, different versions

TECHNICAL DATA

Measuring ranges:	-30...+70 °C (passive sensors) and 0...+50 °C (for U-variant)
Sensor:	for types, see table
Potentiometer:	standard 1kΩ, max. 0.1 W other ratings optional on request, e. g. 100 Ω, 2.5 kΩ, 5 kΩ, 10 kΩ, (optional potentiometer 0...10 V, linear), with angle of rotation limiter
Turn switch:	max. 24 V AC / DC, max. 130 mA, up to 5 steps (0, Auto, I, II, III), with angle of rotation limiter
Rocker switch:	max. 24 V AC / DC, max. 130 mA
Push-buttons:	normally open contact, max. 24 V DC, max. 10 mA
LEDs:	max. 24 V DC (optional max. 24 V AC), standard green (optional red, yellow, or two-colour)
Housing:	plastic, ABS, pure white (similar to RAL 9010), (optional stainless steel <b>V2A</b> (1.4301))
Dimensions:	85 x 85 x 27 mm (Baldur 1) Standard 98 x 98 x 33 mm (Baldur 2) 75 x 75 x 25 mm (stainless steel <b>V2A</b> (1.4301))
Installation:	wall mounting or on in-wall flush box Ø55 mm, base with 4-hole for mounting on vertically or horizontally installed in-wall flush boxes for cable entry from the back, with predetermined breaking point for on-wall cable entry from top / bottom in case of plain on-wall installation
Electrical connection:	0.14 - 1.5 mm <sup>2</sup> via terminal screws, on safety extra-low voltage max. 24 V DC only
Humidity:	max. 90 % r. H., non-precipitating air
Protection class:	III (according to EN 60 730)
Protection type:	IP 30 (according to EN 60 529)
Lettering:	standard is swelling arrow with centre position, unfilled (optional special printing – see last chapter "Accessories")
<b>ACCESSORIES</b>	see last chapter

Potentiometer and  
turn switch with  
**limited angle of rotation**





**RTF xx T**  
(Baldur 1)  
Version with sensor and  
push-button (max. 24 V DC, max. 10 mA)

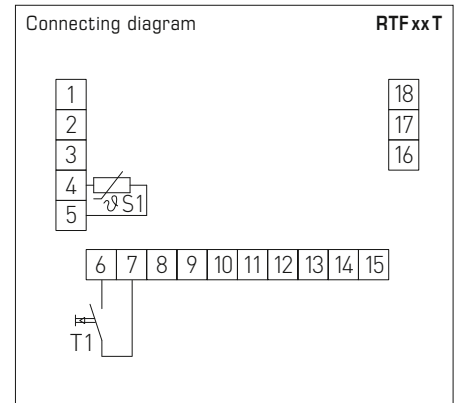

**THERMASGARD® RTF xx T** Room temperature sensors

Type /WG01	Sensor /Output	Item No.	Price
<b>RTF xx T</b>	<b>passive</b>	<b>IP30 (-30...+70 °C)</b>	
RTF Pt100 T	Pt100 (according to DIN EN 60 751, class B)	1101-40A0-1617-000	<b>42,43 €</b>
RTF Pt1000 T	Pt1000 (according to DIN EN 60 751, class B)	1101-40A0-5617-000	<b>42,43 €</b>
RTF Ni1000 T	Ni1000 (according to DIN EN 43 760, class B, TCR = 6180 ppm / K)	1101-40A0-9617-000	<b>44,13 €</b>
RTF NiTK T	Ni1000 TK5000 (TCR = 5000 ppm / K), LG - Ni1000	1101-40A1-0617-000	<b>45,23 €</b>
RTF LM235Z T	LM235Z (TCR = 10 mV / K; 2.73 V at 0 °C), KP10	1101-40A2-1617-000	<b>44,74 €</b>
RTF NTC1,8K T	NTC 1.8K	1101-40A1-2617-000	<b>44,99 €</b>
RTF NTC10K T	NTC 10K	1101-40A1-5617-000	<b>41,83 €</b>
RTF NTC20K T	NTC 20K	1101-40A1-6617-000	<b>41,83 €</b>



**RTF xx LT**  
(Baldur 1)  
Version with sensor, LED (green) and  
push-button (max. 24 V DC, max. 10 mA)

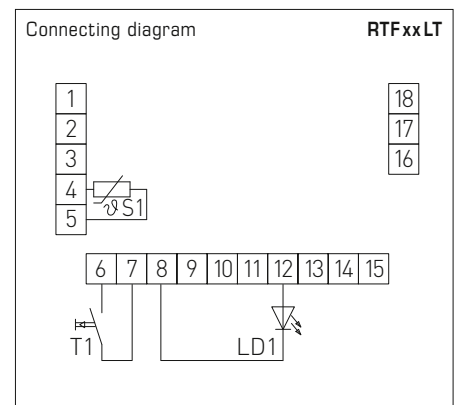

**THERMASGARD® RTF xx LT** Room temperature sensors

Type /WG01	Sensor /Output	Item No.	Price
<b>RTF xx LT</b>	<b>passive</b>	<b>IP30 (-30...+70 °C)</b>	
RTF Pt100 L T	Pt100 (according to DIN EN 60 751, class B)	1101-40A0-1593-002	<b>44,85 €</b>
RTF Pt1000 L T	Pt1000 (according to DIN EN 60 751, class B)	1101-40A0-5593-002	<b>46,49 €</b>
RTF Ni1000 L T	Ni1000 (according to DIN EN 43 760, class B, TCR = 6180 ppm / K)	1101-40A0-9593-002	<b>46,81 €</b>
RTF NiTK L T	Ni1000 TK5000 (TCR = 5000 ppm / K), LG - Ni1000	1101-40A1-0593-002	<b>50,25 €</b>
RTF LM235Z L T	LM235Z (TCR = 10 mV / K; 2.73 V at 0 °C), KP10	1101-40A2-1593-002	<b>45,90 €</b>
RTF NTC1,8K L T	NTC 1.8K	1101-40A1-2593-002	<b>49,96 €</b>
RTF NTC10K L T	NTC 10K	1101-40A1-5593-002	<b>45,28 €</b>
RTF NTC20K L T	NTC 20K	1101-40A1-6593-002	<b>45,28 €</b>



**RTF xx P**  
**RTF xx PU**  
**RTM-U PU**  
(Baldur 1)

Version with sensor and potentiometer (1 kOhm, max. 0.1 W)

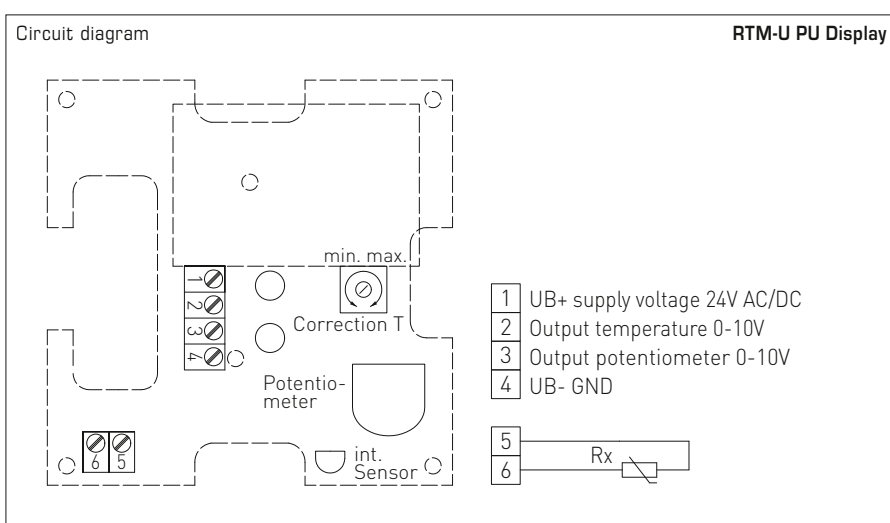
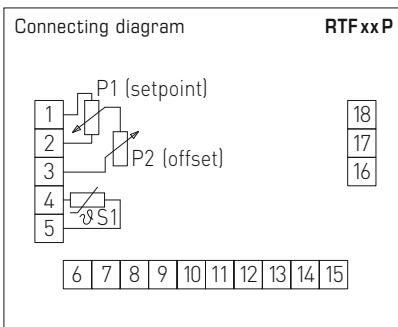

**THERMASGARD® RTF xx P** Room temperature sensors

Type / WG01	Sensor / Output	Display	Item No.	Price
<b>RTF xx P</b>	<b>passive</b>		<b>IP 30</b> (-30...+70 °C)	
RTF Pt100 P	Pt100 (according to DIN EN 60751, class B)		1101-40A0-1001-345	<b>44,85 €</b>
RTF Pt1000 P	Pt1000 (according to DIN EN 60751, class B)		1101-40A0-5001-345	<b>46,07 €</b>
RTF Ni1000 P	Ni1000 (according to DIN EN 43760, class B, TCR = 6180 ppm / K)		1101-40A0-9001-345	<b>47,29 €</b>
RTF NiTK P	Ni1000 TK5000 (TCR = 5000 ppm / K), LG-Ni1000		1101-40A1-0001-345	<b>47,91 €</b>
RTF LM235Z P	LM235Z (TCR = 10 mV / K; 2.73 V at 0 °C), KP10		1101-40A2-1001-345	<b>46,07 €</b>
RTF NTC1,8K P	NTC 1.8K		1101-40A1-2001-345	<b>46,19 €</b>
RTF NTC10K P	NTC 10K		1101-40A1-5001-345	<b>44,85 €</b>
RTF NTC20K P	NTC 20K		1101-40A1-6001-345	<b>44,85 €</b>
<b>RTF xx PU</b>	<b>passive / active</b>		<b>IP 30</b> (0...+50 °C)	
RTF Pt1000 PU	Pt1000 / 0 - 10 V (potentiometer)*		1101-40A0-5004-345	<b>106,69 €</b>
RTF Pt1000 PU	Pt1000 / 0 - 10 V (potentiometer, central position)*		1101-40A0-5004-642	<b>106,69 €</b>
RTF Pt1000 PU	Pt1000 / 0 - 10 V (potentiometer, marking points)*		1101-40A0-5004-050	<b>106,69 €</b>
<b>RTM PU</b>	<b>aktive</b>		<b>IP 30</b> (0...+50 °C)	
RTM-U PU	0 - 10 V (temperature and potentiometer)*		1101-41A1-0004-346	<b>139,80 €</b>
RTM-U PU LCD	0 - 10 V (temperature and potentiometer)*	■	1101-41A1-1004-346	<b>236,79 €</b>

For special orders please specify: **Ohm rating** of potentiometer (standard is 1kOhm; optional 100 Ohm, 2.5kOhm, 5kOhm, 10kOhm, 0-10V), **type of swelling arrow\*** (standard = wedge-shaped, optional with central position or marking points) and differing specific **wiring requests**





**RTF xxPT**  
(Baldur 1)

Version with sensor, potentiometer (1 kOhm, max. 0.1 W) and push-button (max. 24 V DC, max. 10 mA)

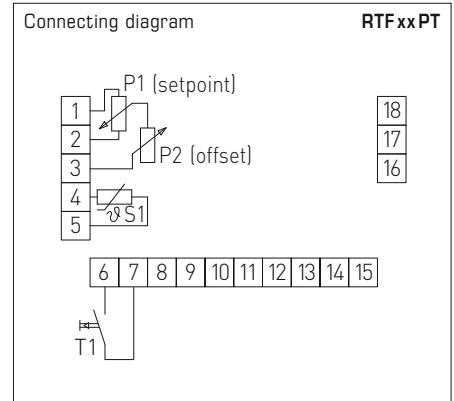

**THERMASGARD® RTF xxPT** Room temperature sensors

Type / WG01	Sensor / Output	Item No.	Price
<b>RTF xx PT</b>	<b>passive</b>	<b>IP30</b> (-30...+70 °C)	
RTF Pt100 P T	Pt100 (according to DIN EN 60 751, class B)	1101-40A0-1021-345	<b>49,60 €</b>
RTF Pt1000 P T	Pt1000 (according to DIN EN 60 751, class B)	1101-40A0-5021-345	<b>45,58 €</b>
RTF Ni1000 P T	Ni1000 (according to DIN EN 43 760, class B, TCR = 6180 ppm / K)	1101-40A0-9021-345	<b>51,78 €</b>
RTF NiTK P T	Ni1000 TK5000 (TCR = 5000 ppm / K), LG - Ni1000	1101-40A1-0021-345	<b>53,96 €</b>
RTF LM235Z P T	LM235Z (TCR = 10 mV / K; 2.73 V at 0 °C), KP10	1101-40A2-1021-345	<b>53,35 €</b>
RTF NTC1,8K P T	NTC 1.8 K	1101-40A1-2021-345	<b>53,46 €</b>
RTF NTC10K P T	NTC 10K	1101-40A1-5021-345	<b>52,08 €</b>
RTF NTC20K P T	NTC 20K	1101-40A1-6021-345	<b>52,08 €</b>
<b>RTF xx PUT</b>	<b>passive / active</b>	<b>IP30</b> (0...+50 °C)	
RTF Pt1000 PU T	Pt1000 / 0 - 10 V (potentiometer)	1101-40B0-5033-345	<b>114,09 €</b>



**RTF xxPLT**  
(Baldur 1)

Version with sensor, potentiometer (1 kOhm, max. 0.1 W), LED (green) and push-button (max. 24 V DC, max. 10 mA)

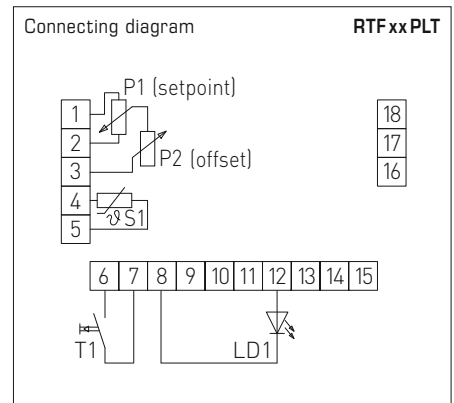

**THERMASGARD® RTF xxPLT** Room temperature sensors

Type / WG01	Sensor / Output	Item No.	Price
<b>RTF xx PLT</b>	<b>passive</b>	<b>IP30</b> (-30...+70 °C)	
RTF Pt100 P L T	Pt100 (according to DIN EN 60 751, class B)	1101-40A0-1663-347	<b>63,22 €</b>
RTF Pt1000 P L T	Pt1000 (according to DIN EN 60 751, class B)	1101-40A0-5663-347	<b>66,39 €</b>
RTF Ni1000 P L T	Ni1000 (according to DIN EN 43 760, class B, TCR = 6180 ppm / K)	1101-40A0-9663-347	<b>66,69 €</b>
RTF NiTK P L T	Ni1000 TK5000 (TCR = 5000 ppm / K), LG - Ni1000	1101-40A1-0663-347	<b>69,58 €</b>
RTF LM235Z P L T	LM235Z (TCR = 10 mV / K; 2.73 V at 0 °C), KP10	1101-40A2-1663-347	<b>65,11 €</b>
RTF NTC1,8K P L T	NTC 1.8 K	1101-40A1-2663-347	<b>69,10 €</b>
RTF NTC10K P L T	NTC 10K	1101-40A1-5663-347	<b>63,22 €</b>
RTF NTC20K P L T	NTC 20K	1101-40A1-6663-347	<b>63,22 €</b>
<b>RTF xx PULT</b>	<b>passive / active</b>	<b>IP30</b> (-30...+70 °C)	
RTF Pt1000 PU L T	Pt1000 / 0 - 10 V (potentiometer)	1101-40B0-5669-347	<b>130,95 €</b>

Room temperature sensors and measuring transducers,  
on-wall, different versions



**RTF xx PW**  
(Baldur 1)

Version with sensor,  
potentiometer (1 kOhm, max. 0.1 W) and  
rocker switch (max. 24 V AC/DC, max. 130 mA)

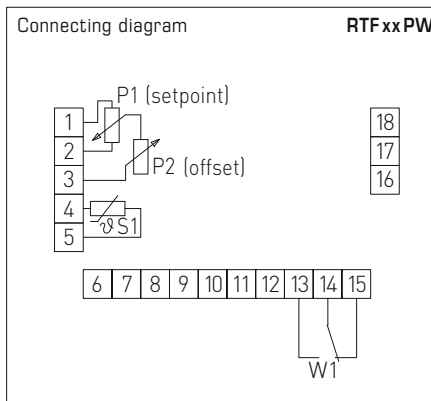

**THERMASGARD® RTF xx PW** Room temperature sensors

Type / WG01	Sensor / Output	Item No.	Price
<b>RTF xx PW</b>	<b>passive</b>	<b>IP 30 (-30...+70 °C)</b>	
RTF Pt100 P W	Pt100 (according to DIN EN 60 751, class B)	1101-40A0-1061-348	<b>50,32 €</b>
RTF Pt1000 P W	Pt1000 (according to DIN EN 60 751, class B)	1101-40A0-5061-348	<b>52,13 €</b>
RTF Ni1000 P W	Ni1000 (according to DIN EN 43 760, class B, TCR = 6180 ppm/K)	1101-40A0-9061-348	<b>52,63 €</b>
RTF NiTK P W	Ni1000 TK5000 (TCR = 5000 ppm/K), LG-Ni1000	1101-40A1-0061-348	<b>54,56 €</b>
RTF LM235Z P W	LM235Z (TCR = 10 mV/K; 2.73 V at 0 °C), KP10	1101-40A2-1061-348	<b>53,96 €</b>
RTF NTC1,8K P W	NTC 1.8K	1101-40A1-2061-348	<b>54,45 €</b>
RTF NTC10K P W	NTC 10K	1101-40A1-5061-348	<b>52,76 €</b>
RTF NTC20K P W	NTC 20K	1101-40A1-6061-348	<b>52,76 €</b>
<b>RTF xx PUW</b>	<b>passive / active</b>	<b>IP 30 (0...+50 °C)</b>	
RTF Pt1000 PU W2	Pt1000 / 0-10 V (potentiometer)	1101-40B0-5067-348	<b>114,70 €</b>



**RTF xx PD**  
(Baldur 2)

Version with sensor,  
potentiometer (1 kOhm, max. 0.1 W) and  
turn switch (max. 24 V AC/DC, max. 130 mA)

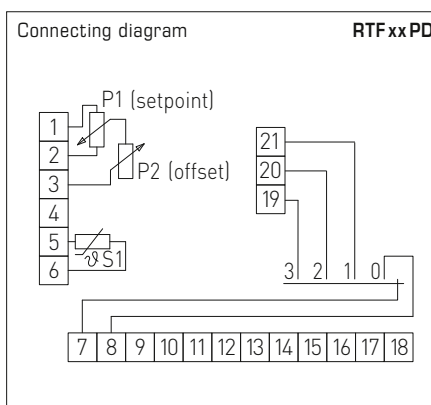

**THERMASGARD® RTF xx PD** Room temperature sensors

Type / WG01	Sensor / Output	Item No.	Price
<b>RTF xx PD</b>	<b>passive</b>	<b>IP 30 (-30...+70 °C)</b>	
RTF Pt100 P D4	Pt100 (according to DIN EN 60 751, class B)	1101-40B0-1007-349	<b>50,81 €</b>
RTF Pt1000 P D4	Pt1000 (according to DIN EN 60 751, class B)	1101-40B0-5007-349	<b>52,68 €</b>
RTF Ni1000 P D4	Ni1000 (according to DIN EN 43 760, class B, TCR = 6180 ppm/K)	1101-40B0-9007-349	<b>52,97 €</b>
RTF NiTK P D4	Ni1000 TK5000 (TCR = 5000 ppm/K), LG-Ni1000	1101-40B1-0007-349	<b>55,17 €</b>
RTF LM235Z P D4	LM235Z (TCR = 10 mV/K; 2.73 V at 0 °C), KP10	1101-40B2-1007-349	<b>54,56 €</b>
RTF NTC1,8K P D4	NTC 1.8K	1101-40B1-2007-349	<b>54,67 €</b>
RTF NTC10K P D4	NTC 10K	1101-40B1-5007-349	<b>53,30 €</b>
RTF NTC20K P D4	NTC 20K	1101-40B1-6007-349	<b>53,30 €</b>
<b>RTF xx PUD</b>	<b>passive / active</b>	<b>IP 30 (0...+50 °C)</b>	
RTF Pt1000 PU D4	Pt1000 / 0-10 V (potentiometer)	1101-40B0-5019-349	<b>115,17 €</b>

Operating elements Baldur 1	Possible combinations	1	2	3	4	5	6
Sensor 1		●	●	●	●	●	●
Sensor 2		●		●			
Sensor 3 LM235Z with calibrating pot (4-wire)		●			●	●	
Potentiometer 1 with/without series resistor		●	●	●	●		
Potentiometer 2 with calibrating pot						●	●
LED 1 (max. one LED)							
LED 2 (max. two LEDs)							
LED 3 (max. three LEDs)							
LED 4 (max. four LEDs)		●	●	●	●	●	●
Rocker switch			●	●			●
Push-button 1 (max. one button)		●		●		●	●
Push-button 2 (max. two buttons)			●	●			

**Please specify in your order:**

**Ohm rating of potentiometer**  
(e. g. 100 Ohm, 1 kOhm, 2.5 kOhm, 5 kOhm, 10 kOhm)

---

**Colour of LED**  
(e. g. green, red, yellow)

---

**Printing, form of swelling arrow**  
(wedge-shaped or with central position, points or numerical scale)

---

**Requested features regarding operating and/or display elements and wiring**

We offer special designs on request in written form including approval drawing.

---

**Special printing:**  
See last chapter "Accessories"

With 4-conductor-circuitry, Sensor 3 is used, thus a maximum of 3 LEDs is possible.  
LM235Z with calibrating pot = calibration of sensor output signal.  
Satchwell switching possible with sensor 2.  
**Turn switches are not possible with Baldur 1!**

Operating elements Baldur 2	Possible combinations	1	2	3	4	5	6	7	8	9	10
Sensor 1		●	●	●	●	●	●	●	●	●	●
Sensor 2 LM235Z with calibrating pot		●						●			
Sensor 3 with heat sink (4-wire)											
Potentiometer 1 (at bottom) with/without series resistor		●	●		●		●	●	●		●
Potentiometer 2 (at top)			●						●		
Key switch (at bottom)				●						●	
Turn switch 1 (at top) with/without series resistor					●						●
Turn switch 2 (at bottom)						●					
LED 1 (max. one LED)											
LED 2 (max. two LEDs)											
LED 3 (max. three LEDs)			●						●		
LED 4 (max. four LEDs)					●						●
LED 5 (max. five LEDs)		●		●		●		●		●	
LED 6 (max. six LEDs)							●				
Rocker switch		●	●	●	●	●	●				
Push-button 1 (max. one button)											
Push-button 2 (max. two buttons)		●	●	●		●	●				●
Push-button 3 (max. three buttons)											
Push-button 4 (max. four buttons)								●	●	●	

Sensor 3 can also be used instead of sensor 1.  
LM235Z with calibrating pot = calibration of sensor output signal.  
In the case cascade connections with turn switch 1, LEDs are not possible!  
**With the Baldur 2 housing, only one operating element is possible at each of the positions "[at bottom]" and "[at top]"!**

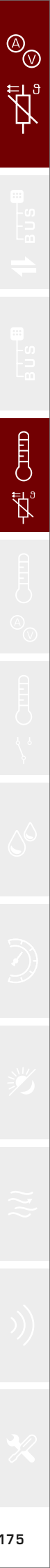

Configuration variants of room operating units

Room temperature sensors and measuring transducers  
in-wall, panel switch programme

An overview of various versions ...

with potentiometer,  
rocker switch and LED



with push-buttons and LEDs



Room temperature sensor



with push-buttons and LEDs



with potentiometer



with potentiometer



with potentiometer,  
push-button, and LED



with potentiometer,  
push-button, and LEDs



with potentiometer,  
push-buttons, and LEDs







with potentiometer,  
push-buttons, and LEDs



with potentiometer,  
push-button, and LED



with potentiometer and turn switch



with potentiometer,  
push-buttons, and LEDs



with potentiometer,  
push-button, and LED



with potentiometer,  
turn switch, and LEDs



with potentiometer  
and rocker switch



with potentiometer,  
push-button, and LED



with potentiometer,  
push-button, and LEDs



**Room temperature sensors**  
**in-wall, panel switch programme,**  
**general**

A room temperature sensor **THERMASGARD® FSTF** is used for air temperature measurement or setpoint adjustment, for presence detection or as room control and operating panel with temperature sensor, push-buttons, potentiometers, status indicators (LEDs).

The in-wall sensor is mounted in high-quality panel switch programmes, ideally of the brands Gira, Berker, Merten, Jung, Siemens or Busch-Jaeger (using in-wall adapters) either individually or in combination with light switches, socket outlets, etc.

It is used in non-aggressive, dust-free environments, in refrigeration, air conditioning and clean room technology, and in interior rooms, such as living rooms, offices, hotels, etc.

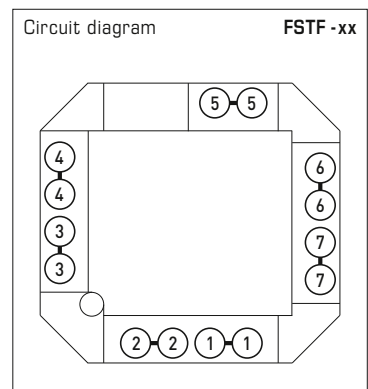

**TECHNICAL DATA**

Measuring ranges:	-30...+60 °C
Sensor / output:	see table, assembled on board, passive
Range suppression:	in the button
Testing current:	< 0.6 mA (Pt1000) < 1.0 mA (Pt100) < 0.3 mA (Ni1000, Ni1000 TK5000) < 2.0 mW (NTC xx) 400 µA...5 mA (LM235Z)
Potentiometers:	standard 1 kΩ, max. 0.1 W (other ratings optional on request, e. g. 100 Ω, 2.5 kΩ, 5 kΩ, 10 kΩ optional 0-10V linear)
Turn switches:	max. 24 V AC / DC, max. 130 mA, max. 5 steps (0, Auto, I, II, III)
Rocker switch:	max. 24 V AC / DC, max. 130 mA
Push-buttons:	normally open contact, max. 24 V DC / 10 mA
LEDs:	max. 24 V DC (optional max. 24 V AC), standard green (red, yellow or two-colour optional)
Installation:	in in-wall flush box Ø 55 mm
Electrical connection:	<b>FSTF-1</b> via screw terminals 0.14 - 1.5 mm <sup>2</sup> , <b>FSTF-xx</b> via plug terminals 1.0 - 2.5 mm <sup>2</sup> , on safety extra-low voltage only, max. 42 V AC, 60 V DC
Humidity:	max. 90 % r.H., non-precipitating air
Protection class:	III (according to EN 60 730)
Protection type:	<b>IP 20</b> (according to EN 60 529)

**SWITCH PROGRAMMES**

Manufacturer:	GIRA System 55 Standard (other switch programmes, manufacturers, and prices upon request)
Housing:	plastic, colour pure white glossy (similar to RAL 9010) (other colours are possible on request with colour variants depending on the respective switch programme)

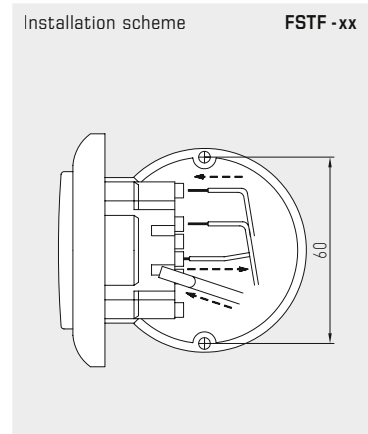
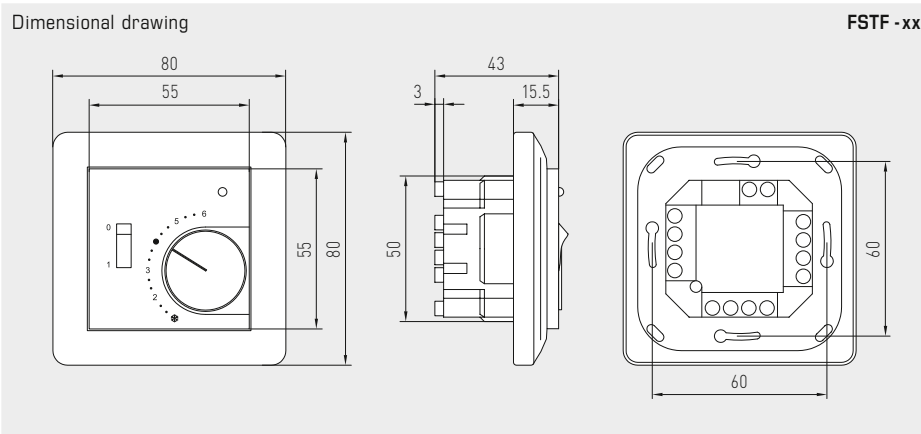

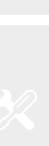

**FSTF 1**  
Standard version  
with sensor

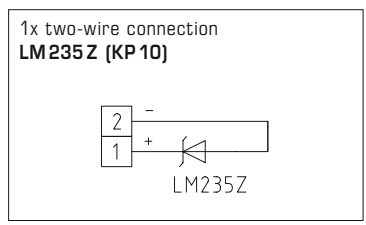
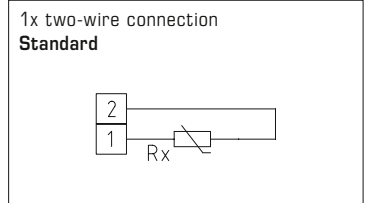

THERMASGARD® FSTF 1 Room temperature sensors			
Type / WG01	Sensor / Output	Item No.	Price
<b>FSTF1</b>	<b>passive</b>	<b>IP20 (-30...+60 °C)</b>	
FSTF1 Pt100	Pt100 (according to DIN EN 60 751, class B)	1101-5020-1000-162	<b>48,37 €</b>
FSTF1 Pt1000	Pt1000 (according to DIN EN 60 751, class B)	1101-5020-5000-162	<b>48,37 €</b>
FSTF1 Ni1000	Ni1000 (according to DIN EN 43 760, class B, TCR = 6180 ppm / K)	1101-5020-9000-162	<b>49,82 €</b>
FSTF1 NiTK	Ni1000 TK5000 (TCR = 5000 ppm / K), LG-Ni1000	1101-5021-0000-162	<b>52,13 €</b>
FSTF1 LM235Z	LM235Z (TCR = 10 mV / K; 2.73 V at 0 °C), KP10	1101-5022-1000-162	<b>48,50 €</b>
FSTF1 NTC1,8K	NTC 1.8K	1101-5021-2000-162	<b>47,91 €</b>
FSTF1 NTC10K	NTC 10K	1101-5021-5000-162	<b>47,41 €</b>
FSTF1 NTC20K	NTC 20K	1101-5021-6000-162	<b>47,41 €</b>

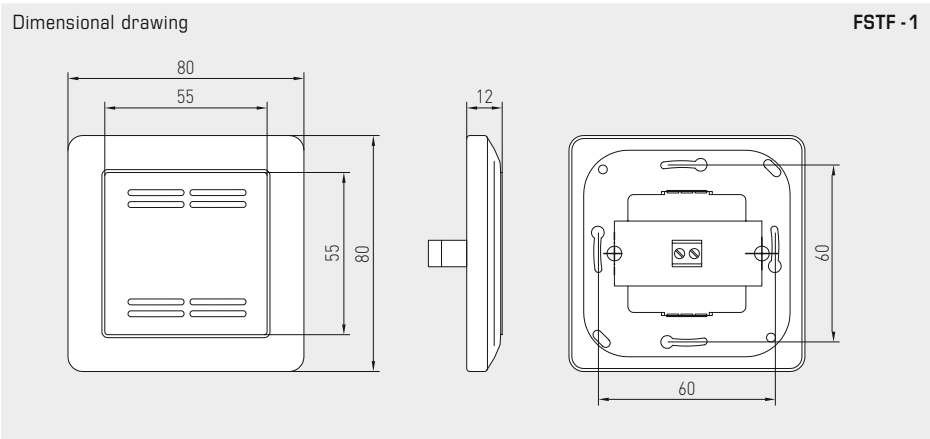

Room temperature sensors  
in-wall, panel switch programme,  
different versions



**FSTFxxLT**  
Version with sensor,  
LED (green), and push-button  
(max. 24 V DC, max. 10 mA)

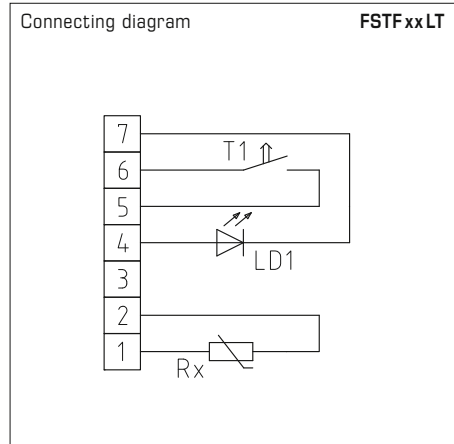

**THERMASGARD® FSTFxxLT** Room temperature sensors

Type/WG01	Sensor/Output	Item No.	Price
<b>FSTFxxLT</b>	<b>passive</b>	<b>IP 20 (-30...+60 °C)</b>	
FSTF Pt100 L T	Pt100 (according to DIN EN 60 751, class B)	1101-5020-1593-350	<b>63,67 €</b>
FSTF Pt1000 L T	Pt1000 (according to DIN EN 60 751, class B)	1101-5020-5593-350	<b>63,67 €</b>
FSTF Ni1000 L T	Ni1000 (according to DIN EN 43 760, class B, TCR = 6180 ppm/K)	1101-5020-9593-350	<b>65,47 €</b>
FSTF NiTK L T	Ni1000 TK5000 (TCR = 5000 ppm/K), LG-Ni1000	1101-5021-0593-350	<b>65,47 €</b>
FSTF LM235Z L T	LM235Z (TCR = 10 mV/K; 2.73 V at 0 °C), KP10	1101-5022-1593-350	<b>64,26 €</b>
FSTF NTC1,8K L T	NTC 1.8K	1101-5021-2593-350	<b>63,67 €</b>
FSTF NTC10K L T	NTC 10K	1101-5021-5593-350	<b>63,05 €</b>
FSTF NTC20K L T	NTC 20K	1101-5021-6593-350	<b>63,05 €</b>



**FSTFxxLD2**  
Version with sensor,  
LED (green), and turn switch (2-step)  
(max. 24 V AC/DC, max. 130 mA)

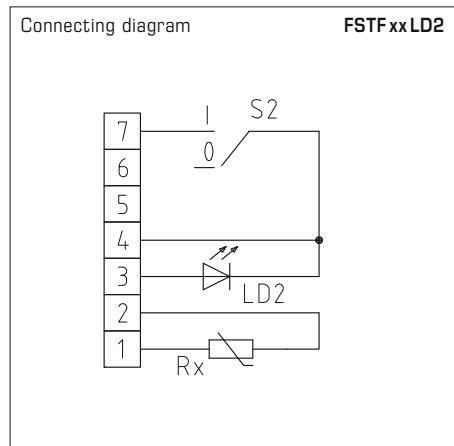

**THERMASGARD® FSTFxxLD2** Room temperature sensors

Type/WG01	Sensor/Output	Item No.	Price
<b>FSTFxxLD2</b>	<b>passive</b>	<b>IP 20 (-30...+60 °C)</b>	
FSTF Pt100 D2 L	Pt100 (according to DIN EN 60 751, class B)	1101-5020-1631-351	<b>72,86 €</b>
FSTF Pt1000 D2 L	Pt1000 (according to DIN EN 60 751, class B)	1101-5020-5631-351	<b>72,86 €</b>
FSTF Ni1000 D2 L	Ni1000 (according to DIN EN 43 760, class B, TCR = 6180 ppm/K)	1101-5020-9631-351	<b>75,16 €</b>
FSTF NiTK D2 L	Ni1000 TK5000 (TCR = 5000 ppm/K), LG-Ni1000	1101-5021-0631-351	<b>75,16 €</b>
FSTF LM235Z D2 L	LM235Z (TCR = 10 mV/K; 2.73 V at 0 °C), KP10	1101-5022-1631-351	<b>73,35 €</b>
FSTF NTC1,8K D2 L	NTC 1.8K	1101-5021-2631-351	<b>73,35 €</b>
FSTF NTC10K D2 L	NTC 10K	1101-5021-5631-351	<b>72,75 €</b>
FSTF NTC20K D2 L	NTC 20K	1101-5021-6631-351	<b>72,75 €</b>



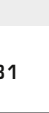

**FSTFxxLD4**  
Version with sensor,  
LED (green) and turn switch (4-step)  
(max. 24 V AC / DC, max. 130 mA)

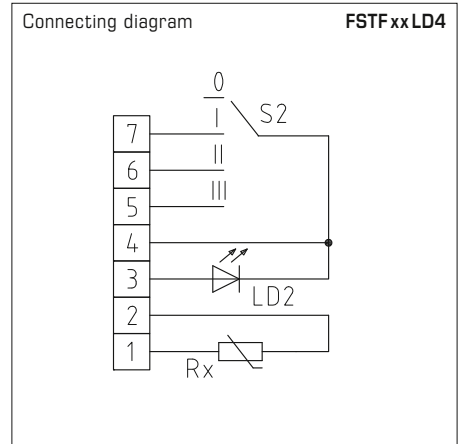

**THERMASGARD® FSTFxxLD4** Room temperature sensors

Type / WG01	Sensor / Output	Item No.	Price
<b>FSTFxxLD4</b>	<b>passive</b>	<b>IP20 (-30...+60 °C)</b>	
FSTF Pt100 D4 L	Pt100 (according to DIN EN 60751, class B)	1101-5020-1643-352	<b>75,79 €</b>
FSTF Pt1000 D4 L	Pt1000 (according to DIN EN 60751, class B)	1101-5020-5643-352	<b>75,79 €</b>
FSTF Ni1000 D4 L	Ni1000 (according to DIN EN 43760, class B, TCR = 6180 ppm / K)	1101-5020-9643-352	<b>77,60 €</b>
FSTF NiTK D4 L	Ni1000 TK5000 (TCR = 5000 ppm / K), LG - Ni1000	1101-5021-0643-352	<b>77,60 €</b>
FSTF LM235Z D4 L	LM235Z (TCR = 10 mV / K; 2.73 V at 0 °C), KP10	1101-5022-1643-352	<b>76,39 €</b>
FSTF NTC1,8K D4 L	NTC 1.8K	1101-5021-2643-352	<b>75,79 €</b>
FSTF NTC10K D4 L	NTC 10K	1101-5021-5643-352	<b>75,16 €</b>
FSTF NTC20K D4 L	NTC 20K	1101-5021-6643-352	<b>75,16 €</b>



**FSTFxxP**  
Version with sensor  
and potentiometer  
(1 kOhm, max. 0.1 W)

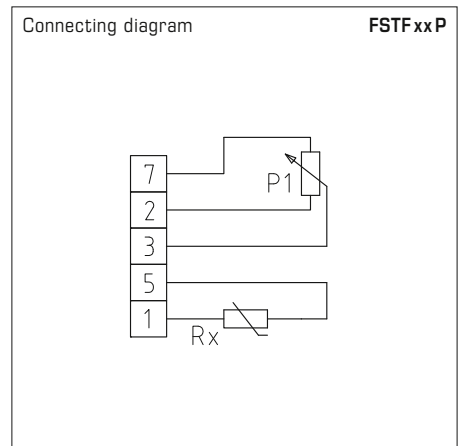

**THERMASGARD® FSTFxxP** Room temperature sensors

Type / WG01	Sensor / Output	Item No.	Price
<b>FSTFxxP</b>	<b>passive</b>	<b>IP20 (-30...+60 °C)</b>	
FSTF Pt100 P	Pt100 (according to DIN EN 60751, class B)	1101-5020-1001-282	<b>78,20 €</b>
FSTF Pt1000 P	Pt1000 (according to DIN EN 60751, class B)	1101-5020-5001-162	<b>78,20 €</b>
FSTF Ni1000 P	Ni1000 (according to DIN EN 43760, class B, TCR = 6180 ppm / K)	1101-5020-9001-162	<b>78,94 €</b>
FSTF NiTK P	Ni1000 TK5000 (TCR = 5000 ppm / K), LG - Ni1000	1101-5021-0001-162	<b>81,60 €</b>
FSTF LM235Z P	LM235Z (TCR = 10 mV / K; 2.73 V at 0 °C), KP10	1101-5022-1001-162	<b>74,56 €</b>
FSTF NTC1,8K P	NTC 1.8K	1101-5021-2001-162	<b>75,79 €</b>
FSTF NTC10K P	NTC 10K	1101-5021-5001-162	<b>74,56 €</b>
FSTF NTC20K P	NTC 20K	1101-5021-6001-162	<b>74,56 €</b>

Room temperature sensors  
in-wall, panel switch programme,  
different versions



**FSTFxxPLW**  
Version with sensor,  
potentiometer (1 kOhm, max. 0.1 W),  
LED (green), and rocker switch  
(max. 24 V AC/DC, max. 130 mA)

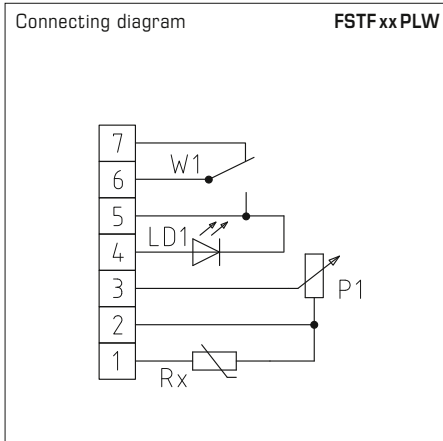

**THERMASGARD® FSTF xx PLW** Room temperature sensors

Type/WG01	Sensor / Output	Item No.	Price
<b>FSTFxxPLW</b>	<b>passive</b>	<b>IP 20 (-30...+60 °C)</b>	
FSTF Pt100 P L W	Pt100 (according to DIN EN 60 751, class B)	1101-5020-1655-353	<b>99,24 €</b>
FSTF Pt1000 P L W	Pt1000 (according to DIN EN 60 751, class B)	1101-5020-5655-353	<b>101,73 €</b>
FSTF Ni1000 P L W	Ni1000 (according to DIN EN 43 760, class B, TCR = 6180 ppm/K)	1101-5020-9655-353	<b>102,33 €</b>
FSTF NiTK P L W	Ni1000 TK5000 (TCR = 5000 ppm/K), LG-Ni1000	1101-5021-0655-353	<b>104,80 €</b>
FSTF LM235Z P L W	LM235Z (TCR = 10 mV/K; 2.73 V at 0 °C), KP10	1101-5022-1655-353	<b>99,85 €</b>
FSTF NTC1,8K P L W	NTC 1.8K	1101-5021-2655-353	<b>105,30 €</b>
FSTF NTC10K P L W	NTC 10K	1101-5021-5655-353	<b>99,24 €</b>
FSTF NTC20K P L W	NTC 20K	1101-5021-6655-353	<b>99,24 €</b>



**FSTFxxPLT**  
Version with sensor,  
potentiometer (1 kOhm, max. 0.1 W),  
LED (green), and push-button  
(max. 24 V DC, max. 10 mA)

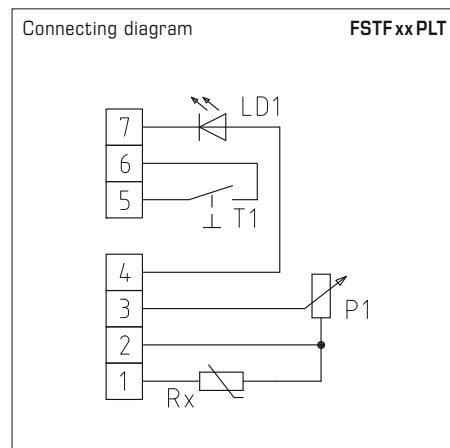

**THERMASGARD® FSTF xx PLT** Room temperature sensors

Type/WG01	Sensor / Output	Item No.	Price
<b>FSTFxxPLT</b>	<b>passive</b>	<b>IP 20 (-30...+60 °C)</b>	
FSTF Pt100 P L T	Pt100 (according to DIN EN 60 751, class B)	1101-5020-1663-162	<b>99,18 €</b>
FSTF Pt1000 P L T	Pt1000 (according to DIN EN 60 751, class B)	1101-5020-5663-162	<b>101,67 €</b>
FSTF Ni1000 P L T	Ni1000 (according to DIN EN 43 760, class B, TCR = 6180 ppm/K)	1101-5020-9663-350	<b>102,27 €</b>
FSTF NiTK P L T	Ni1000 TK5000 (TCR = 5000 ppm/K), LG-Ni1000	1101-5021-0663-350	<b>104,75 €</b>
FSTF LM235Z P L T	LM235Z (TCR = 10 mV/K; 2.73 V at 0 °C), KP10	1101-5022-1663-350	<b>99,78 €</b>
FSTF NTC1,8K P L T	NTC 1.8K	1101-5021-2663-350	<b>105,24 €</b>
FSTF NTC10K P L T	NTC 10K	1101-5021-5663-350	<b>99,18 €</b>
FSTF NTC20K P L T	NTC 20K	1101-5021-6663-350	<b>99,18 €</b>



**FSTFxxPD4**  
Version with sensor,  
potentiometer (1 kOhm, max. 0.1 W)  
and turn switch  
(max. 24 V AC / DC, max. 130 mA)

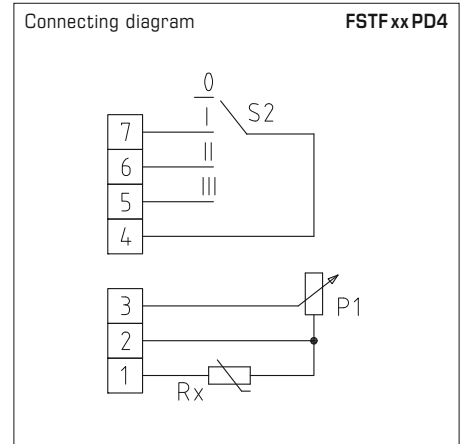

**THERMASGARD® FSTF xx PD4** Room temperature sensors

Type / WG01	Sensor / Output	Item No.	Price
<b>FSTF xx PD4</b>	<b>passive</b>	<b>IP20 (-30...+60 °C)</b>	
FSTF Pt100 P D4	Pt100 (according to DIN EN 60751, class B)	1101-5020-1007-354	<b>102,28 €</b>
FSTF Pt1000 P D4	Pt1000 (according to DIN EN 60751, class B)	1101-5020-5007-354	<b>104,76 €</b>
FSTF Ni1000 P D4	Ni1000 (according to DIN EN 43760, class B, TCR = 6180 ppm / K)	1101-5020-9007-354	<b>105,38 €</b>
FSTF NiTK P D4	Ni1000 TK5000 (TCR = 5000 ppm / K), LG-Ni1000	1101-5021-0007-354	<b>107,87 €</b>
FSTF LM235Z P D4	LM235Z (TCR = 10 mV / K; 2.73 V at 0 °C), KP10	1101-5022-1007-354	<b>102,28 €</b>
FSTF NTC1,8K P D4	NTC 1.8K	1101-5021-2007-354	<b>104,12 €</b>
FSTF NTC10K P D4	NTC 10K	1101-5021-5007-354	<b>101,67 €</b>
FSTF NTC20K P D4	NTC 20K	1101-5021-6007-354	<b>101,67 €</b>



**FSTF xx P2L2T**  
Version with sensor,  
potentiometer (1 kOhm, max. 0.1 W),  
2 LEDs (green, red), and 2 push-buttons (max.  
24 V DC, max. 10 mA)

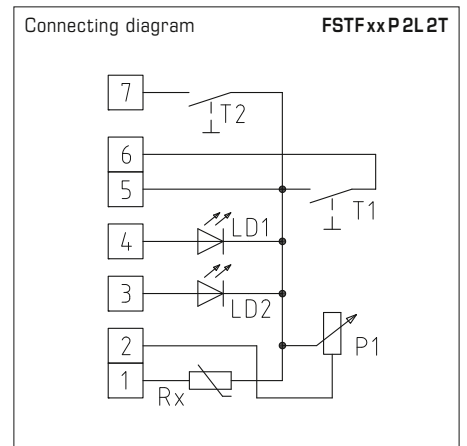

**THERMASGARD® FSTF xx P2L2T** Room temperature sensors

Type / WG01	Sensor / Output	Item No.	Price
<b>FSTF xx P2L2T</b>	<b>passive</b>	<b>IP20 (-30...+60 °C)</b>	
FSTF Pt100 P 2L 2T	Pt100 (according to DIN EN 60751, class B)	1101-5020-1672-256	<b>104,75 €</b>
FSTF Pt1000 P 2L 2T	Pt1000 (according to DIN EN 60751, class B)	1101-5020-5672-256	<b>108,14 €</b>
FSTF Ni1000 P 2L 2T	Ni1000 (according to DIN EN 43760, class B, TCR = 6180 ppm / K)	1101-5020-9672-256	<b>111,66 €</b>
FSTF NiTK P2L2T	Ni1000 TK5000 (TCR = 5000 ppm / K), LG-Ni1000	1101-5021-0672-256	<b>113,72 €</b>
FSTF LM235Z P 2L 2T	LM235Z (TCR = 10 mV / K; 2.73 V at 0 °C), KP10	1101-5022-1672-256	<b>107,18 €</b>
FSTF NTC1,8K P 2L 2T	NTC 1.8K	1101-5021-2672-256	<b>110,59 €</b>
FSTF NTC10K P 2L 2T	NTC 10K	1101-5021-5672-256	<b>105,24 €</b>
FSTF NTC20K P 2L 2T	NTC 20K	1101-5021-6672-256	<b>105,24 €</b>

**In-ceiling temperature sensors  
with passive output**

**THERMASGARD® DTF** is a small in-ceiling resistance thermometer with passive output for in-wall installation, e.g. in plasterboard walls or suspended ceilings. The in-ceiling temperature sensor DTF is preferably installed in ceilings and walls, blends in seamlessly with the overall architectural design and detects the temperature at the surface. The connecting head is pluggable for quick, easy mounting.

TECHNICAL DATA	
Measuring range:	-20...+90 °C
Sensors / output:	see table, passive
Connection type:	4-wire connection <b>terminal 1 / 2: +</b> (marked red, wire colours: yellow, brown) <b>terminal 3 / 4: -</b> (marked black, wire colours: white, green)
Testing current:	< 0.6 mA (Pt1000) < 1.0 mA (Pt100) < 0.3 mA (Ni1000, Ni1000 TK5000) < 2.0 mW (NTC xx) 400 µA...5 mA (LM235Z)
Connecting head:	plastic, material polycarbonate (PC), colour white (can be painted as an option), <b>pluggable</b>
Connecting cable:	PVC, LiYY, 4 x 0.14 mm <sup>2</sup> , KL = approx. 2 m
Process connection:	inside suspended ceiling, ceiling cutout Ø = 30 mm, cover Ø = < 35 mm
Insulating resistance:	≥ 100 MΩ, at +20 °C (500V DC)
Humidity:	< 95 % r.H., non-precipitating air
Protection class:	III (according to EN 60 730)
Protection type:	<b>IP 30</b> (according EN 60 529) Sensor in the built-in state

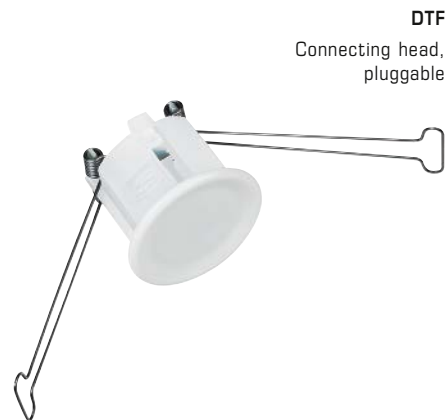

**DTF**  
Connecting head,  
pluggable

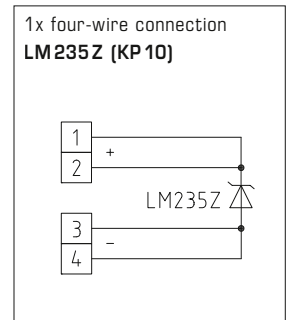
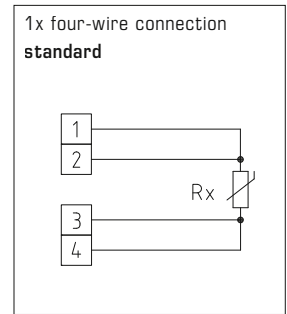
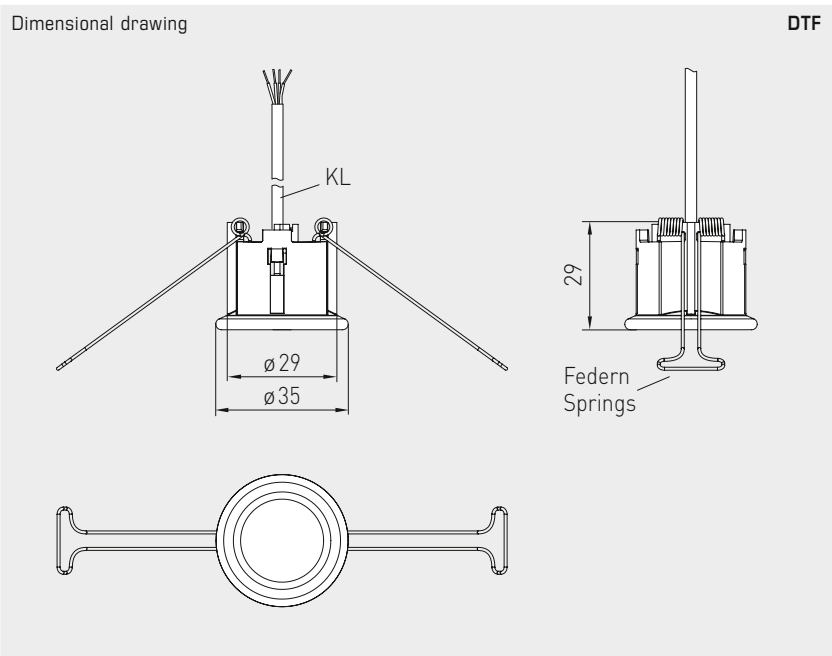





DTF



THERMASGARD® DTF		In-ceiling temperature sensors	
Type / WG03	Sensor / Output	Item No.	Price
<b>DTF</b>		<b>IP30</b>	
DTF Pt100	Pt100 (according to DIN EN 60 751, class B)	1101-60C0-1003-000	<b>38,80 €</b>
DTF Pt1000	Pt1000 (according to DIN EN 60 751, class B)	1101-60C0-5003-000	<b>38,80 €</b>
DTF Ni1000	Ni1000 (according to DIN EN 43760, class B, TCR = 6180 ppm/K)	1101-60C0-9003-000	<b>38,55 €</b>
DTF NiTK	Ni1000 TK5000 (TCR = 5000 ppm/K), LG-Ni1000	1101-60C1-0003-000	<b>42,33 €</b>
DTF LM235Z	LM235Z (TCR = 10 mV/K; 2.73 V at 0 °C), KP10	1101-60C2-1003-000	<b>39,70 €</b>
DTF NTC1,8K	NTC 1.8K	1101-60C1-2003-000	<b>39,70 €</b>
DTF NTC10K	NTC 10K	1101-60C1-5003-000	<b>39,70 €</b>
DTF NTC20K	NTC 20K	1101-60C1-6003-000	<b>39,70 €</b>
Note:	Other sensors optional	on request	



**Outside temperature sensors / wet room temperature sensors  
with passive output**

Outside wall resistance thermometer / weather sensor **THERMASGARD® ATF 1** (internal sensor) with passive output, housing made of impact-resistant plastic and quick-locking screws.

Outside wall resistance thermometer / weather sensor **THERMASGARD® ATF 01** (internal sensor) with passive output, housing made of impact-resistant plastic and snap-on lid.

It is used to measure outside temperatures, temperatures in wet room areas, e.g. as an outdoor sensor, weather sensor for installation on outside walls, in cold storage buildings and greenhouses, in halls, in the industrial sector and in agriculture. Installation in outdoor areas preferably at the north side of a building or in a protected place. In cases of direct solar irradiation, we recommend the use of our **WS01** or **WS04** sun protection hood (accessory).

**TECHNICAL DATA**

Measuring range:	-50...+90 °C
Sensors / output:	passive (see table), sensors internal
Connection type:	2-wire connection (4-wire connection on PT100/PT1000A, optional on other sensors)
Testing current:	< 0.6 mA (Pt1000) < 1.0 mA (Pt100) < 0.3 mA (Ni1000, Ni1000 TK5000) < 2.0 mW (NTC xx) 400 µA...5 mA (LM235Z)
Housing:	plastic, UV-resistant, material polyamide, 30% glass-globe reinforced, colour traffic white (similar to RAL 9016), <b>ATF01 with snap-on lid,</b> <b>ATF1 with quick-locking screws</b> (slotted / Phillips head combination)
Housing dimensions:	72 x 64 x 37.8 mm (Tyr 1 / Tyr 01)
Cable connection:	<b>cable gland</b> , plastic (M 16 x 1.5; with strain relief, exchangeable, max. inner diameter 10.4 mm) <b>or</b> <b>M12 connector</b> according to DIN EN 61076-2-101
Electrical connection:	0.14 - 1.5 mm <sup>2</sup> , via terminal screws
Insulating resistance:	≥ 100 MΩ, at +20 °C (500 V DC)
Humidity:	< 95% r. H., non-precipitating air
Protection class:	III (according to EN 60 730)
Protection type:	<b>ATF01 IP 54</b> (according to EN 60 529) Housing tested, TÜV SÜD, Report No. 713160960A (Tyr 01) <b>ATF1 IP 67</b> (according to EN 60 529) Housing tested, TÜV SÜD, Report No. 713139052 (Tyr 1)

1x two-wire connection  
**standard**

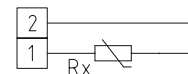

1x two-wire connection  
**LM235Z (KP 10)**

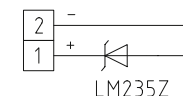

1x four-wire connection  
(optional)

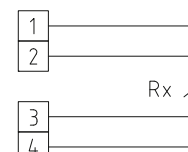

**THERMASGARD® ATF 01** Outside temperature sensors / wet room temperature sensors, *Standard*  
with snap-on lid

Type/WG03	Sensor/Output	Item No.	Price
<b>ATF01</b>		<b>IP 54</b>	
ATF01 Pt100	Pt100 (according to DIN EN 60 751, class B)	1101-1030-1003-000	<b>14,56 €</b>
ATF01 Pt1000	Pt1000 (according to DIN EN 60 751, class B)	1101-1030-5001-000	<b>17,05 €</b>
ATF01 Ni1000	Ni1000 (according to DIN EN 43 760, class B, TCR = 6180 ppm / K)	1101-1030-9001-000	<b>17,81 €</b>
ATF01 NiTK	Ni1000 TK5000 (TCR = 5000 ppm / K), LG-Ni1000	1101-1031-0001-000	<b>20,67 €</b>
ATF01 LM235Z	LM235Z (TCR = 10 mV / K; 2.73 V at 0 °C), KP10	1101-1032-1001-000	<b>15,01 €</b>
ATF01 NTC1,8K	NTC 1.8K	1101-1031-2001-000	<b>13,83 €</b>
ATF01 NTC10K	NTC 10K	1101-1031-5001-000	<b>13,83 €</b>
ATF01 NTC20K	NTC 20K	1101-1031-6001-000	<b>13,83 €</b>
Extra charge:	Other sensors optional Cable connection with <b>M12 connector</b> according to DIN EN 61076-2-101		on request on request
<b>ACCESSORIES</b>			
<b>WS-01</b>	<b>Sun and ball-impact protection hood</b> , 184 x 180 x 80 mm, stainless steel <b>V2A</b> (1.4301)	7100-0040-2000-000	<b>30,26 €</b>
<b>WS-04</b>	<b>Weather and sun protection hood</b> , 130 x 180 x 135 mm, stainless steel <b>V2A</b> (1.4301)	7100-0040-7000-000	<b>35,70 €</b>

For further information see last chapter!

Dimensional drawing

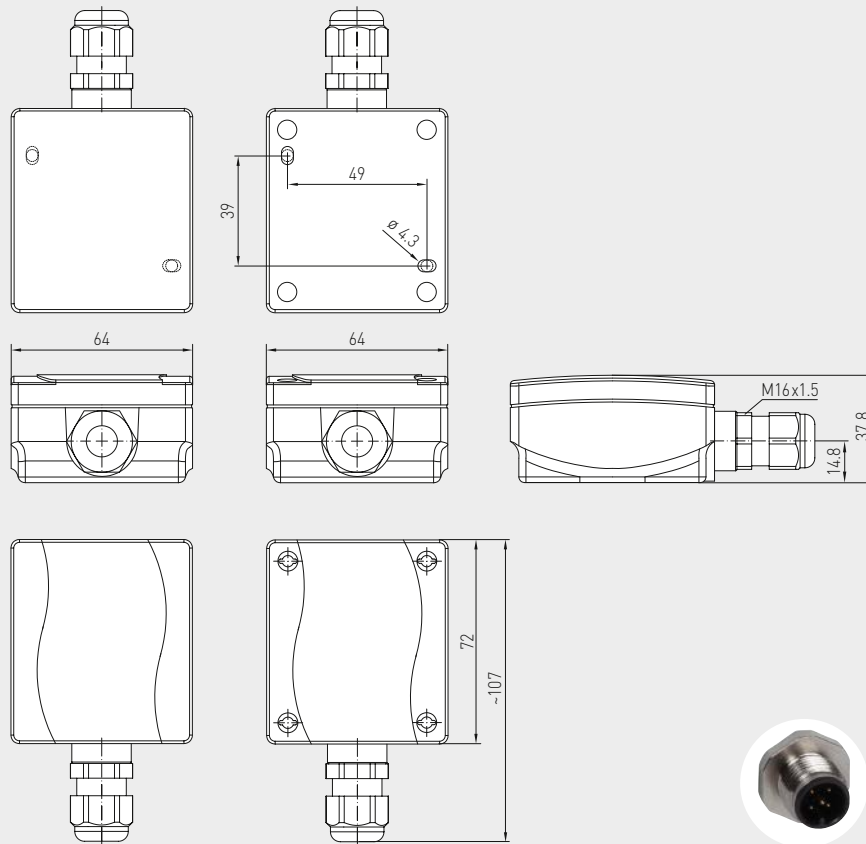

with snap-on lid

with quick-locking screws

M12 connector  
(optional on request)

ATF 1  
ATF01

ATF 01  
with snap-on lid  
(IP54)



ATF 1  
with quick-locking screws  
(IP67)



THERMASGARD® ATF 1 Outside temperature sensors / wet room temperature sensors, Premium with quick-locking screws

Type / WG03	Sensor / Output	Item No.	Price
<b>ATF 1</b>		<b>IP67</b>	
ATF1 Pt100	Pt100 (according to DIN EN 60 751, class B)	1101-1040-1003-000	16,83 €
ATF1 Pt1000	Pt1000 (according to DIN EN 60 751, class B)	1101-1040-5001-000	19,31 €
ATF1 Pt1000A	Pt1000 (according to VDI / VDE 3512, class A-TGA)	1101-1040-6003-000	22,58 €
ATF1 Ni1000	Ni1000 (according to DIN EN 43 760, class B, TCR = 6180 ppm / K)	1101-1040-9001-000	18,86 €
ATF1 NiTK	Ni1000 TK5000 (TCR = 5000 ppm / K), LG - Ni1000	1101-1041-0001-000	22,93 €
ATF1 LM235Z	LM235Z (TCR = 10 mV / K; 2.73 V at 0 °C), KP10	1101-1042-1001-000	17,27 €
ATF1 NTC1,8K	NTC 1.8 K	1101-1041-2001-000	15,36 €
ATF1 NTC10K	NTC 10K	1101-1041-5001-000	15,36 €
ATF1 NTC20K	NTC 20K	1101-1041-6001-000	15,36 €

Extra charge:: Other sensors optional on request  
Cable connection with M12 connector according to DIN EN 61076-2-101 on request

ACCESSORIES

<b>WS-01</b>	<b>Sun and ball-impact protection hood, 184 x 180 x 80 mm, stainless steel V2A (1.4301)</b>	7100-0040-2000-000	30,26 €
<b>WS-04</b>	<b>Weather and sun protection hood, 130 x 180 x 135 mm, stainless steel V2A (1.4301)</b>	7100-0040-7000-000	35,70 €

For further information see last chapter!

**Outside temperature sensors / wet room temperature sensors  
with passive output**

Outside wall resistance thermometers / weather sensors **THERMASGARD® ATF 2** (external sensor) with passive output and housing made of impact-resistant plastic and with quick-locking screws.

It is used to measure outside temperatures, temperatures in wet room areas, e.g. as a weather sensor, for installation on outside walls, in cold storage buildings and greenhouses, in halls, in the industrial sector and in agriculture. Outdoor installation should preferably be performed at the north side of a building or in a protected place.

In cases of direct solar irradiation, we recommend the use of our **WS01** or **WS04** sun protection hood (accessory) or the device version with installed sun protection hood **SS02** (available upon request).

**TECHNICAL DATA**

Measuring range:	-50...+90 °C
Sensors / output:	passive (see table), sensor inside external sensor tube, stainless steel <b>V4A</b> (1.4571) <b>(Perfect Sensor Protection)</b>
Connection type:	2-wire connection (4-wire connection on PT100/PT1000A, optional on other sensors)
Testing current:	< 0.6 mA (Pt1000) < 1.0 mA (Pt100) < 0.3 mA (Ni1000, Ni1000 TK5000) < 2.0 mW (NTC xx) 400 µA...5 mA (LM235Z)
Housing:	plastic, UV-resistant, material polyamide, 30% glass-globe reinforced, with quick-locking screws (slotted / Phillips head combination), colour traffic white (similar to RAL 9016)
Housing dimensions:	72 x 64 x 37.8 mm (Tyr 1)
Cable connection:	<b>cable gland</b> , plastic (M 16 x 1.5; with strain relief, exchangeable, max. inner diameter 10.4 mm) <b>or</b> <b>M12 connector</b> according to DIN EN 61076-2-101
Electrical connection:	0.14 - 1.5 mm <sup>2</sup> via terminal screws
Insulating resistance:	≥ 100 MΩ, at +20 °C (500 V DC)
Permissible humidity:	< 95% r. H., non-precipitating air
Protection class:	III (according to EN 60 730)
Protection type:	<b>IP65</b> (according to EN 60 529) Housing tested, TÜV SÜD, Report No. 713139052 (Tyr 1)
Optional:	with sun protection hood <b>SS02</b> (available on request)

1x two-wire connection  
**standard**

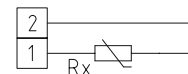

1x two-wire connection  
**LM235Z (KP 10)**

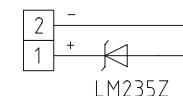

1x four-wire connection  
(optional)

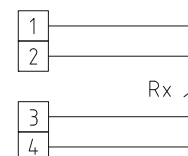

High-performance encapsulation against  
vibration, mechanical stress and humidity





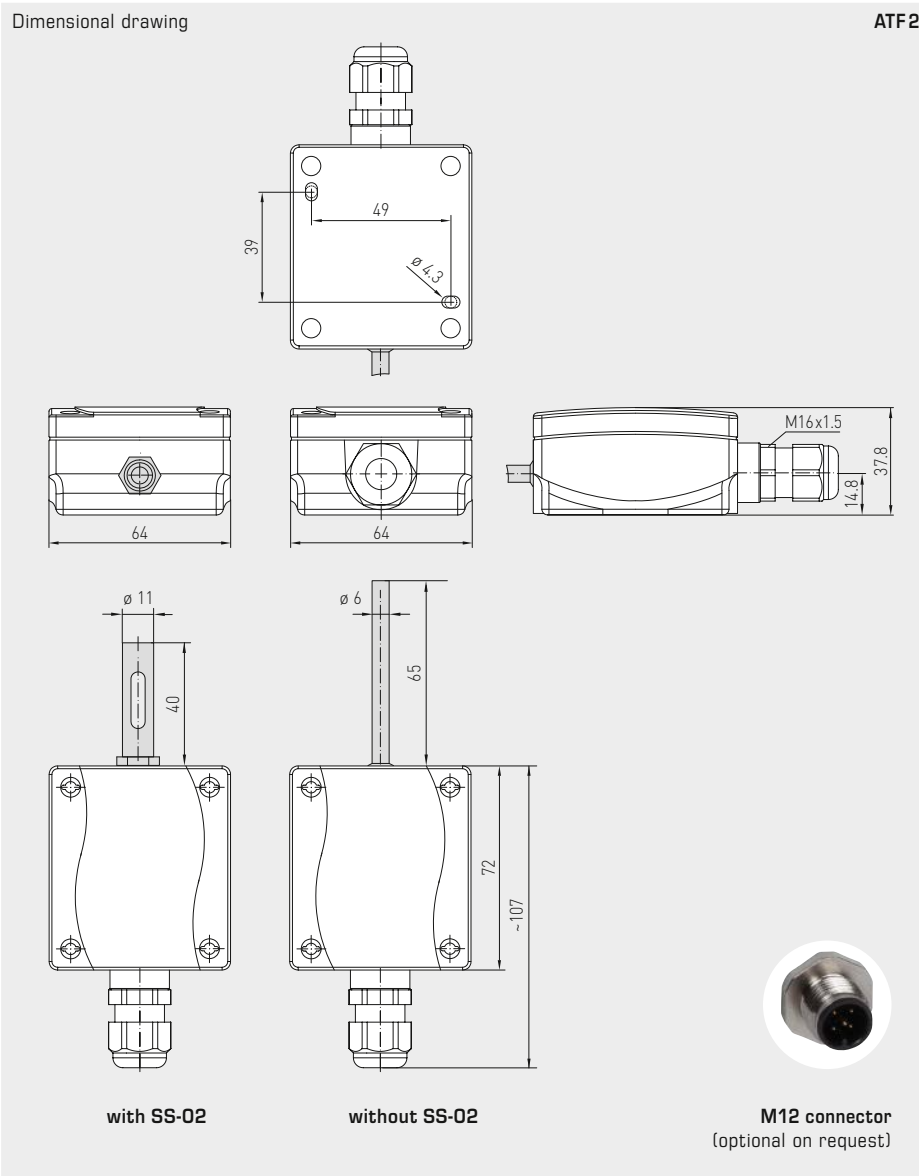

**THERMASGARD® ATF 2** Outside temperature sensors / wet room temperature sensors

Type / WG03	Sensor / Output	Item No.	Price
<b>ATF 2</b>			
ATF2 Pt100	Pt100 (according to DIN EN 60 751, class B)	1101-1050-1003-000	<b>36,70 €</b>
ATF2 Pt1000	Pt1000 (according to DIN EN 60 751, class B)	1101-1050-5001-000	<b>36,70 €</b>
ATF2 Pt1000A	Pt1000 (according to VDI / VDE 3512, class A-TGA)	1101-1050-6003-000	<b>45,58 €</b>
ATF2 Ni1000	Ni1000 (according to DIN EN 43 760, class B, TCR = 6180 ppm / K)	1101-1050-9001-000	<b>38,85 €</b>
ATF2 NiTK	Ni1000 TK5000 (TCR = 5000 ppm / K), LG-Ni1000	1101-1051-0001-000	<b>38,85 €</b>
ATF2 LM235Z	LM235Z (TCR = 10 mV / K; 2.73 V at 0 °C), KP10	1101-1052-1001-000	<b>36,14 €</b>
ATF2 NTC1,8K	NTC 1.8 K	1101-1051-2001-000	<b>35,40 €</b>
ATF2 NTC10K	NTC 10K	1101-1051-5001-000	<b>35,40 €</b>
ATF2 NTC20K	NTC 20K	1101-1051-6001-000	<b>35,40 €</b>
Extra charge:	Other sensors optional	on request	
	with sun protection hood <b>SS02</b>	on request	<b>9,28 €</b>
	Cable connection with <b>M12 connector</b> according to DIN EN 61076-2-101	on request	
<b>ACCESSORIES</b>			
<b>WS-01</b>	<b>Sun and ball-impact protection hood, 184 x 180 x 80 mm, stainless steel V2A (1.4301)</b>	7100-0040-2000-000	<b>30,26 €</b>
<b>WS-04</b>	<b>Weather and sun protection hood, 130 x 180 x 135 mm, stainless steel V2A (1.4301)</b>	7100-0040-7000-000	<b>35,70 €</b>

For further information see last chapter!

**Immersion / screw-in / duct temperature sensors  
with passive output**

**Patented quality product (Immersion sensor patent no. DE 10 2012 017 500.0)**

**THERMASGARD® TF 43** is a resistance thermometer with a passive output, housing made from impact-resistant plastic with snap-on lid, and straight protective tube.

**THERMASGARD® TF 65** is a resistance thermometer with a passive output, housing made from impact-resistant plastic with quick-locking screws, and straight protective tube.

These immersion / screw-in / duct temperature sensors are electric contact thermometers for temperature measurement in liquids and gases, which are installed for example in piping systems and vessels. For aggressive media, stainless steel immersion sleeves must be used.

Applications of these temperature sensors in piping systems, in heating technology, in storage tanks, in district heating compact stations, in hot and cold-water systems, in oil and lubricant circulation systems, in mechanical, apparatus and plant engineering as well as in the entire industrial sector.

**TECHNICAL DATA**

Measuring range:	-30...+150 °C ( $T_{max}$ NTC = +150 °C, $T_{max}$ LM235Z = +125 °C)
Sensors / output:	see table, passive ( <b>Perfect Sensor Protection</b> ) (optional also with two sensors)
Connection type:	2-wire connection (4-wire connection on PT100/PT1000A, optional on other sensors)
Testing current:	< 0.6 mA (Pt1000) < 1.0 mA (Pt100) < 0.3 mA (Ni1000, Ni1000 TK5000) < 2.0 mW (NTC xx) 400 µA...5 mA (LM235Z)
Insulating resistance:	≥ 100 MΩ, at +20 °C (500 V DC)
Ambient temperature:	-20...+100 °C
Housing:	plastic, UV-resistant, material polyamide, 30% glass-globe reinforced, colour traffic white (similar to RAL 9016) <b>TF 43 with snap-on lid</b> <b>TF 65 with quick-locking screws</b> (slotted / Phillips head combination)
Housing dimensions:	72 x 64 x 37.8 mm (Tyr 1 / Tyr 01)
Cable connection:	<b>cable gland</b> , plastic (M 16 x 1.5; with strain relief, exchangeable, max. inner diameter 10.4 mm) <b>or</b> <b>M12 connector</b> according to DIN EN 61076-2-101 (optional on request)
Electrical connection:	0.14 - 1.5 mm <sup>2</sup> , via terminal screws
Protective tube:	stainless steel, <b>V4A</b> (1.4571), Ø = 6 mm, inserted length (EL) = 50 - 400 mm (see table)
Permissible humidity:	< 95% r. H., non-precipitating air
Protection class:	III (according to EN 60 730)
Protection type:	<b>TF 43 IP 54</b> (according to EN 60 529)* Housing tested, TÜV SÜD, Report No. 713160960A (Tyr 01) <b>TF 65 IP 65</b> (according to EN 60 529)* Housing tested, TÜV SÜD, Report No. 713139052 (Tyr 1) * Housing in the built-in state

**ACCESSORIES**

<b>MF-15-K</b>	<b>Mounting flange</b> , plastic, 56.8 x 84.3 mm, Ø = 15.2 mm tube gland, $T_{max}$ = +100 °C
<b>TH08-ms/xx</b>	<b>Immersion sleeve</b> , brass, nickel-plated, Ø = 8 mm, $T_{max}$ = +150 °C, $p_{max}$ = 10 bar
<b>TH08-VA/xx</b>	<b>Immersion sleeve</b> , stainless steel, <b>V4A</b> (1.4571), Ø = 8 mm, $T_{max}$ = +600 °C, $p_{max}$ = 40 bar
<b>TH08-VA/xx/90</b>	<b>Immersion sleeve</b> , stainless steel, <b>V4A</b> (1.4571), with neck tube (90 mm), Ø = 8 mm, $T_{max}$ = +600 °C, $p_{max}$ = 40 bar

High-performance encapsulation against  
vibration, mechanical stress and humidity

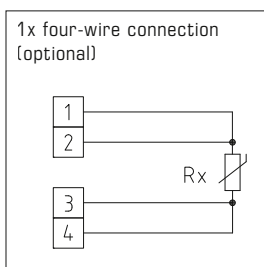
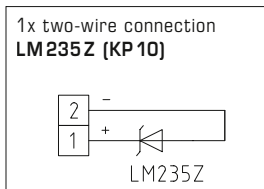
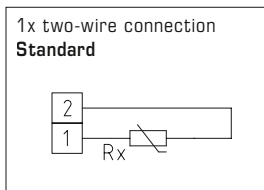

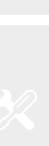

Dimensional drawing

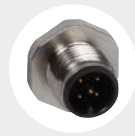
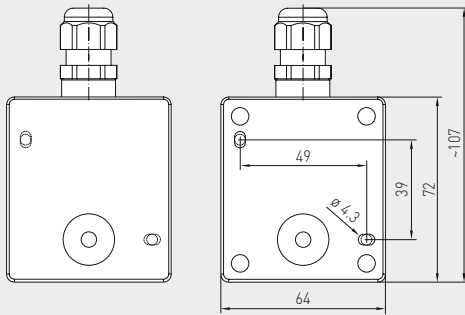

M12 connector  
(optional on request)

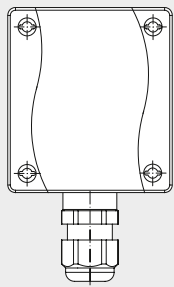
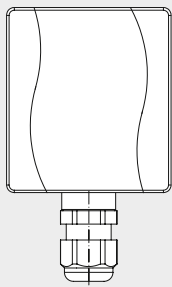
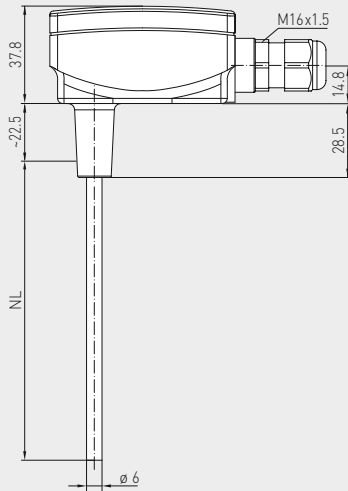
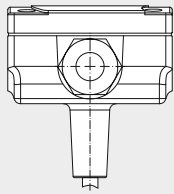

with snap-on lid

with quick-locking screws

TF43  
TF65

TF43  
with snap-on lid  
(IP54)



TF65  
with quick-locking screws  
(IP65)



**PATENTED**



TFxx  
Basic device  
with accessories

Immersion / screw-in / duct temperature sensors  
with passive output

**THERMASGARD® TF 65** Temperature sensors (Basic device with quick-locking screws), *Premium*

Type / WG03 / EL	Sensor / Output	Item No.	Price
<b>TF65 PT100 xx</b>	<b>Pt100</b>	<b>IP 65</b>	
TF65 Pt100 50mm	Pt100 (according to DIN EN 60 751, class B)	1101-7020-1013-000	<b>36,02 €</b>
TF65 Pt100 100mm	Pt100 (according to DIN EN 60 751, class B)	1101-7020-1023-000	<b>37,49 €</b>
TF65 Pt100 150mm	Pt100 (according to DIN EN 60 751, class B)	1101-7020-1033-000	<b>38,96 €</b>
TF65 Pt100 200mm	Pt100 (according to DIN EN 60 751, class B)	1101-7020-1043-000	<b>39,53 €</b>
TF65 Pt100 250mm	Pt100 (according to DIN EN 60 751, class B)	1101-7020-1053-000	<b>41,33 €</b>
TF65 Pt100 300mm	Pt100 (according to DIN EN 60 751, class B)	1101-7020-1063-000	<b>42,69 €</b>
TF65 Pt100 350mm	Pt100 (according to DIN EN 60 751, class B)	1101-7020-1073-000	<b>43,47 €</b>
TF65 Pt100 400mm	Pt100 (according to DIN EN 60 751, class B)	1101-7020-1083-000	<b>44,50 €</b>
<b>TF65 PT1000 xx</b>	<b>Pt1000</b>	<b>IP 65</b>	
TF65 Pt1000 50mm	Pt1000 (according to DIN EN 60 751, class B)	1101-7020-5011-000	<b>38,50 €</b>
TF65 Pt1000 100mm	Pt1000 (according to DIN EN 60 751, class B)	1101-7020-5021-000	<b>39,98 €</b>
TF65 Pt1000 150mm	Pt1000 (according to DIN EN 60 751, class B)	1101-7020-5031-000	<b>41,44 €</b>
TF65 Pt1000 200mm	Pt1000 (according to DIN EN 60 751, class B)	1101-7020-5041-000	<b>42,00 €</b>
TF65 Pt1000 250mm	Pt1000 (according to DIN EN 60 751, class B)	1101-7020-5051-000	<b>43,82 €</b>
TF65 Pt1000 300mm	Pt1000 (according to DIN EN 60 751, class B)	1101-7020-5061-000	<b>45,17 €</b>
TF65 Pt1000 350mm	Pt1000 (according to DIN EN 60 751, class B)	1101-7020-5071-000	<b>45,73 €</b>
TF65 Pt1000 400mm	Pt1000 (according to DIN EN 60 751, class B)	1101-7020-5081-000	<b>46,52 €</b>
<b>TF65 PT1000A xx</b>	<b>Pt1000A</b>	<b>IP 65</b>	
TF65 Pt1000A 50mm	Pt1000 (according to VDI / VDE 3512, class A-TGA)	1101-7020-6013-000	<b>40,35 €</b>
TF65 Pt1000A 100mm	Pt1000 (according to VDI / VDE 3512, class A-TGA)	1101-7020-6023-000	<b>41,00 €</b>
TF65 Pt1000A 150mm	Pt1000 (according to VDI / VDE 3512, class A-TGA)	1101-7020-6033-000	<b>43,14 €</b>
TF65 Pt1000A 200mm	Pt1000 (according to VDI / VDE 3512, class A-TGA)	1101-7020-6043-000	<b>43,70 €</b>
TF65 Pt1000A 250mm	Pt1000 (according to VDI / VDE 3512, class A-TGA)	1101-7020-6053-000	<b>45,51 €</b>
TF65 Pt1000A 300mm	Pt1000 (according to VDI / VDE 3512, class A-TGA)	1101-7020-6063-000	<b>46,97 €</b>
TF65 Pt1000A 350mm	Pt1000 (according to VDI / VDE 3512, class A-TGA)	1101-7020-6073-000	<b>48,44 €</b>
TF65 Pt1000A 400mm	Pt1000 (according to VDI / VDE 3512, class A-TGA)	1101-7020-6083-000	<b>48,66 €</b>
<b>TF65 Ni1000 xx</b>	<b>Ni1000</b>	<b>IP 65</b>	
TF65 Ni1000 50mm	Ni1000 (according to DIN EN 43 760, class B, TCR = 6180 ppm / K)	1101-7020-9011-000	<b>37,83 €</b>
TF65 Ni1000 100mm	Ni1000 (according to DIN EN 43 760, class B, TCR = 6180 ppm / K)	1101-7020-9021-000	<b>39,64 €</b>
TF65 Ni1000 150mm	Ni1000 (according to DIN EN 43 760, class B, TCR = 6180 ppm / K)	1101-7020-9031-000	<b>41,10 €</b>
TF65 Ni1000 200mm	Ni1000 (according to DIN EN 43 760, class B, TCR = 6180 ppm / K)	1101-7020-9041-000	<b>41,67 €</b>
TF65 Ni1000 250mm	Ni1000 (according to DIN EN 43 760, class B, TCR = 6180 ppm / K)	1101-7020-9051-000	<b>43,47 €</b>
TF65 Ni1000 300mm	Ni1000 (according to DIN EN 43 760, class B, TCR = 6180 ppm / K)	1101-7020-9061-000	<b>44,82 €</b>
TF65 Ni1000 350mm	Ni1000 (according to DIN EN 43 760, class B, TCR = 6180 ppm / K)	1101-7020-9071-000	<b>45,73 €</b>
TF65 Ni1000 400mm	Ni1000 (according to DIN EN 43 760, class B, TCR = 6180 ppm / K)	1101-7020-9081-000	<b>46,30 €</b>
<b>TF65 Ni1000TK xx</b>	<b>Ni1000 TK5000</b>	<b>IP 65</b>	
TF65 NiTK 50mm	Ni1000 TK5000 (TCR = 5000 ppm / K), LG - Ni1000	1101-7021-0011-000	<b>37,83 €</b>
TF65 NiTK 100mm	Ni1000 TK5000 (TCR = 5000 ppm / K), LG - Ni1000	1101-7021-0021-000	<b>39,64 €</b>
TF65 NiTK 150mm	Ni1000 TK5000 (TCR = 5000 ppm / K), LG - Ni1000	1101-7021-0031-000	<b>41,10 €</b>
TF65 NiTK 200mm	Ni1000 TK5000 (TCR = 5000 ppm / K), LG - Ni1000	1101-7021-0041-000	<b>41,67 €</b>
TF65 NiTK 250mm	Ni1000 TK5000 (TCR = 5000 ppm / K), LG - Ni1000	1101-7021-0051-000	<b>43,47 €</b>
TF65 NiTK 300mm	Ni1000 TK5000 (TCR = 5000 ppm / K), LG - Ni1000	1101-7021-0061-000	<b>44,82 €</b>
TF65 NiTK 350mm	Ni1000 TK5000 (TCR = 5000 ppm / K), LG - Ni1000	1101-7021-0071-000	<b>45,73 €</b>
TF65 NiTK 400mm	Ni1000 TK5000 (TCR = 5000 ppm / K), LG - Ni1000	1101-7021-0081-000	<b>42,27 €</b>

Continued on next page...

High-performance encapsulation against  
vibration, mechanical stress and humidity





THERMASGARD® TF 65 Temperature sensors (Basic device with quick-locking screws), <i>Premium</i>			
Type/WG03 /EL	Sensor/Output	Item No.	Price
<b>TF65 LM235Z xx</b>	<b>LM235Z</b>	<b>IP65</b>	
TF65 LM235Z 50mm	LM235Z (TCR = 10 mV/K; 2.73 V at 0 °C), KP10	1101-7022-1011-000	<b>36,58 €</b>
TF65 LM235Z 100mm	LM235Z (TCR = 10 mV/K; 2.73 V at 0 °C), KP10	1101-7022-1021-000	<b>37,94 €</b>
TF65 LM235Z 150mm	LM235Z (TCR = 10 mV/K; 2.73 V at 0 °C), KP10	1101-7022-1031-000	<b>39,41 €</b>
TF65 LM235Z 200mm	LM235Z (TCR = 10 mV/K; 2.73 V at 0 °C), KP10	1101-7022-1041-000	<b>39,98 €</b>
TF65 LM235Z 250mm	LM235Z (TCR = 10 mV/K; 2.73 V at 0 °C), KP10	1101-7022-1051-000	<b>41,89 €</b>
TF65 LM235Z 300mm	LM235Z (TCR = 10 mV/K; 2.73 V at 0 °C), KP10	1101-7022-1061-000	<b>43,25 €</b>
TF65 LM235Z 350mm	LM235Z (TCR = 10 mV/K; 2.73 V at 0 °C), KP10	1101-7022-1071-000	<b>44,04 €</b>
TF65 LM235Z 400mm	LM235Z (TCR = 10 mV/K; 2.73 V at 0 °C), KP10	1101-7022-1081-000	<b>44,60 €</b>
<b>TF65 NTC 1.8K xx</b>	<b>NTC 1.8K</b>	<b>IP65</b>	
TF65 NTC1,8K 50mm	NTC 1.8K	1101-7021-2011-000	<b>34,56 €</b>
TF65 NTC1,8K 100mm	NTC 1.8K	1101-7021-2021-000	<b>36,02 €</b>
TF65 NTC1,8K 150mm	NTC 1.8K	1101-7021-2031-000	<b>37,49 €</b>
TF65 NTC1,8K 200mm	NTC 1.8K	1101-7021-2041-000	<b>37,94 €</b>
TF65 NTC1,8K 250mm	NTC 1.8K	1101-7021-2051-000	<b>39,85 €</b>
TF65 NTC1,8K 300mm	NTC 1.8K	1101-7021-2061-000	<b>41,21 €</b>
TF65 NTC1,8K 350mm	NTC 1.8K	1101-7021-2071-000	<b>41,95 €</b>
TF65 NTC1,8K 400mm	NTC 1.8K	1101-7021-2081-000	<b>42,91 €</b>
<b>TF65 NTC10K xx</b>	<b>NTC 10K</b>	<b>IP65</b>	
TF65 NTC10K 50mm	NTC 10K	1101-7021-5011-000	<b>34,56 €</b>
TF65 NTC10K 100mm	NTC 10K	1101-7021-5021-000	<b>36,02 €</b>
TF65 NTC10K 150mm	NTC 10K	1101-7021-5031-000	<b>37,49 €</b>
TF65 NTC10K 200mm	NTC 10K	1101-7021-5041-000	<b>37,94 €</b>
TF65 NTC10K 250mm	NTC 10K	1101-7021-5051-000	<b>39,85 €</b>
TF65 NTC10K 300mm	NTC 10K	1101-7021-5061-000	<b>41,21 €</b>
TF65 NTC10K 350mm	NTC 10K	1101-7021-5071-000	<b>41,95 €</b>
TF65 NTC10K 400mm	NTC 10K	1101-7021-5081-000	<b>42,91 €</b>
<b>TF65 NTC20K xx</b>	<b>NTC 20K</b>	<b>IP65</b>	
TF65 NTC20K 50mm	NTC 20K	1101-7021-6011-000	<b>34,56 €</b>
TF65 NTC20K 100mm	NTC 20K	1101-7021-6021-000	<b>36,02 €</b>
TF65 NTC20K 150mm	NTC 20K	1101-7021-6031-000	<b>37,49 €</b>
TF65 NTC20K 200mm	NTC 20K	1101-7021-6041-000	<b>37,94 €</b>
TF65 NTC20K 250mm	NTC 20K	1101-7021-6051-000	<b>39,74 €</b>
TF65 NTC20K 300mm	NTC 20K	1101-7021-6061-000	<b>41,21 €</b>
TF65 NTC20K 350mm	NTC 20K	1101-7021-6071-000	<b>41,95 €</b>
TF65 NTC20K 400mm	NTC 20K	1101-7021-6081-000	<b>42,91 €</b>
Note:	Other sensors optional	on request	
Optional:	Cable connection with <b>M12 connector</b> according to DIN EN 61076-2-101	on request	



Immersion / screw-in / duct temperature sensors  
with passive output

**THERMASGARD® TF 43** Temperature sensors (Basic device with snap-on lid), *Standard*

Type / WG03 / EL	Sensor / Output	Item No.	Price
<b>TF43 PT100 xx</b>	<b>Pt100</b>	<b>IP 54</b>	
TF43 Pt100 50mm	Pt100 (according to DIN EN 60 751, class B)	1101-7010-1013-000	26,92 €
TF43 Pt100 100mm	Pt100 (according to DIN EN 60 751, class B)	1101-7010-1023-000	27,04 €
TF43 Pt100 150mm	Pt100 (according to DIN EN 60 751, class B)	1101-7010-1033-000	27,90 €
TF43 Pt100 200mm	Pt100 (according to DIN EN 60 751, class B)	1101-7010-1043-000	28,68 €
TF43 Pt100 250mm	Pt100 (according to DIN EN 60 751, class B)	1101-7010-1053-000	30,14 €
TF43 Pt100 300mm	Pt100 (according to DIN EN 60 751, class B)	1101-7010-1063-000	32,62 €
TF43 Pt100 350mm	Pt100 (according to DIN EN 60 751, class B)	1101-7010-1073-000	33,62 €
TF43 Pt100 400mm	Pt100 (according to DIN EN 60 751, class B)	1101-7010-1083-000	34,69 €
<b>TF43 PT1000 xx</b>	<b>Pt1000</b>	<b>IP 54</b>	
TF43 Pt1000 50mm	Pt1000 (according to DIN EN 60 751, class B)	1101-7010-5011-000	26,92 €
TF43 Pt1000 100mm	Pt1000 (according to DIN EN 60 751, class B)	1101-7010-5021-000	27,04 €
TF43 Pt1000 150mm	Pt1000 (according to DIN EN 60 751, class B)	1101-7010-5031-000	27,90 €
TF43 Pt1000 200mm	Pt1000 (according to DIN EN 60 751, class B)	1101-7010-5041-000	28,68 €
TF43 Pt1000 250mm	Pt1000 (according to DIN EN 60 751, class B)	1101-7010-5051-000	30,14 €
TF43 Pt1000 300mm	Pt1000 (according to DIN EN 60 751, class B)	1101-7010-5061-000	32,62 €
TF43 Pt1000 350mm	Pt1000 (according to DIN EN 60 751, class B)	1101-7010-5071-000	33,62 €
TF43 Pt1000 400mm	Pt1000 (according to DIN EN 60 751, class B)	1101-7010-5081-000	34,69 €
<b>TF43 PT1000A xx</b>	<b>Pt1000A</b>	<b>IP 54</b>	
TF43 Pt1000A 50mm	Pt1000 (according to VDI/VDE 3512, class A-TGA)	1101-7010-6013-000	28,61 €
TF43 Pt1000A 100mm	Pt1000 (according to VDI/VDE 3512, class A-TGA)	1101-7010-6023-000	28,74 €
TF43 Pt1000A 150mm	Pt1000 (according to VDI/VDE 3512, class A-TGA)	1101-7010-6033-000	29,59 €
TF43 Pt1000A 200mm	Pt1000 (according to VDI/VDE 3512, class A-TGA)	1101-7010-6043-000	30,37 €
TF43 Pt1000A 250mm	Pt1000 (according to VDI/VDE 3512, class A-TGA)	1101-7010-6053-000	31,83 €
TF43 Pt1000A 300mm	Pt1000 (according to VDI/VDE 3512, class A-TGA)	1101-7010-6063-000	34,31 €
TF43 Pt1000A 350mm	Pt1000 (according to VDI/VDE 3512, class A-TGA)	1101-7010-6073-000	35,32 €
TF43 Pt1000A 400mm	Pt1000 (according to VDI/VDE 3512, class A-TGA)	1101-7010-6083-000	36,39 €
<b>TF43 Ni1000 xx</b>	<b>Ni 1000</b>	<b>IP 54</b>	
TF43 Ni1000 50mm	Ni1000 (according to DIN EN 43 760, class B, TCR = 6180 ppm/K)	1101-7010-9011-000	27,59 €
TF43 Ni1000 100mm	Ni1000 (according to DIN EN 43 760, class B, TCR = 6180 ppm/K)	1101-7010-9021-000	30,20 €
TF43 Ni1000 150mm	Ni1000 (according to DIN EN 43 760, class B, TCR = 6180 ppm/K)	1101-7010-9031-000	30,42 €
TF43 Ni1000 200mm	Ni1000 (according to DIN EN 43 760, class B, TCR = 6180 ppm/K)	1101-7010-9041-000	31,09 €
TF43 Ni1000 250mm	Ni1000 (according to DIN EN 43 760, class B, TCR = 6180 ppm/K)	1101-7010-9051-000	31,96 €
TF43 Ni1000 300mm	Ni1000 (according to DIN EN 43 760, class B, TCR = 6180 ppm/K)	1101-7010-9061-000	34,07 €
TF43 Ni1000 350mm	Ni1000 (according to DIN EN 43 760, class B, TCR = 6180 ppm/K)	1101-7010-9071-000	35,04 €
TF43 Ni1000 400mm	Ni1000 (according to DIN EN 43 760, class B, TCR = 6180 ppm/K)	1101-7010-9081-000	36,61 €
<b>TF43 Ni1000TK xx</b>	<b>Ni1000 TK5000</b>	<b>IP 54</b>	
TF43 NiTK 50mm	Ni1000 TK5000 (TCR = 5000 ppm/K), LG-Ni1000	1101-7011-0011-000	27,64 €
TF43 NiTK 100mm	Ni1000 TK5000 (TCR = 5000 ppm/K), LG-Ni1000	1101-7011-0021-000	30,26 €
TF43 NiTK 150mm	Ni1000 TK5000 (TCR = 5000 ppm/K), LG-Ni1000	1101-7011-0031-000	30,57 €
TF43 NiTK 200mm	Ni1000 TK5000 (TCR = 5000 ppm/K), LG-Ni1000	1101-7011-0041-000	31,22 €
TF43 NiTK 250mm	Ni1000 TK5000 (TCR = 5000 ppm/K), LG-Ni1000	1101-7011-0051-000	32,07 €
TF43 NiTK 300mm	Ni1000 TK5000 (TCR = 5000 ppm/K), LG-Ni1000	1101-7011-0061-000	34,20 €
TF43 NiTK 350mm	Ni1000 TK5000 (TCR = 5000 ppm/K), LG-Ni1000	1101-7011-0071-000	35,27 €
TF43 NiTK 400mm	Ni1000 TK5000 (TCR = 5000 ppm/K), LG-Ni1000	1101-7011-0081-000	36,74 €

Continued on next page...

High-performance encapsulation against  
vibration, mechanical stress and humidity



THERMASGARD® TF 43 Temperature sensors (Basic device with snap-on lid), <i>Standard</i>			
Type/WG03/EL	Sensor/Output	Item No.	Price
<b>TF43 LM235Z xx</b>	<b>LM235Z</b>	<b>IP54</b>	
TF43 LM235Z 50mm	LM235Z (TCR = 10 mV / K; 2.73 V at 0 °C), KP10	1101-7012-1011-000	28,13 €
TF43 LM235Z 100mm	LM235Z (TCR = 10 mV / K; 2.73 V at 0 °C), KP10	1101-7012-1021-000	28,44 €
TF43 LM235Z 150mm	LM235Z (TCR = 10 mV / K; 2.73 V at 0 °C), KP10	1101-7012-1031-000	29,47 €
TF43 LM235Z 200mm	LM235Z (TCR = 10 mV / K; 2.73 V at 0 °C), KP10	1101-7012-1041-000	30,14 €
TF43 LM235Z 250mm	LM235Z (TCR = 10 mV / K; 2.73 V at 0 °C), KP10	1101-7012-1051-000	30,49 €
TF43 LM235Z 300mm	LM235Z (TCR = 10 mV / K; 2.73 V at 0 °C), KP10	1101-7012-1061-000	33,10 €
TF43 LM235Z 350mm	LM235Z (TCR = 10 mV / K; 2.73 V at 0 °C), KP10	1101-7012-1071-000	33,50 €
TF43 LM235Z 400mm	LM235Z (TCR = 10 mV / K; 2.73 V at 0 °C), KP10	1101-7012-1081-000	35,60 €
<b>TF43 NTC 1.8K xx</b>	<b>NTC 1.8K</b>	<b>IP54</b>	
TF43 NTC1,8K 50mm	NTC 1.8K	1101-7011-2011-000	26,92 €
TF43 NTC1,8K 100mm	NTC 1.8K	1101-7011-2021-000	28,38 €
TF43 NTC1,8K 150mm	NTC 1.8K	1101-7011-2031-000	29,10 €
TF43 NTC1,8K 200mm	NTC 1.8K	1101-7011-2041-000	29,78 €
TF43 NTC1,8K 250mm	NTC 1.8K	1101-7011-2051-000	31,22 €
TF43 NTC1,8K 300mm	NTC 1.8K	1101-7011-2061-000	32,25 €
TF43 NTC1,8K 350mm	NTC 1.8K	1101-7011-2071-000	33,34 €
TF43 NTC1,8K 400mm	NTC 1.8K	1101-7011-2081-000	34,20 €
<b>TF43 NTC10K xx</b>	<b>NTC 10K</b>	<b>IP54</b>	
TF43 NTC10K 50mm	NTC 10K	1101-7011-5011-000	26,92 €
TF43 NTC10K 100mm	NTC 10K	1101-7011-5021-000	28,38 €
TF43 NTC10K 150mm	NTC 10K	1101-7011-5031-000	29,10 €
TF43 NTC10K 200mm	NTC 10K	1101-7011-5041-000	29,78 €
TF43 NTC10K 250mm	NTC 10K	1101-7011-5051-000	31,22 €
TF43 NTC10K 300mm	NTC 10K	1101-7011-5061-000	32,25 €
TF43 NTC10K 350mm	NTC 10K	1101-7011-5071-000	33,34 €
TF43 NTC10K 400mm	NTC 10K	1101-7011-5081-000	34,20 €
<b>TF43 NTC20K xx</b>	<b>NTC 20K</b>	<b>IP54</b>	
TF43 NTC20K 50mm	NTC 20K	1101-7011-6011-000	26,92 €
TF43 NTC20K 100mm	NTC 20K	1101-7011-6021-000	28,38 €
TF43 NTC20K 150mm	NTC 20K	1101-7011-6031-000	29,10 €
TF43 NTC20K 200mm	NTC 20K	1101-7011-6041-000	29,78 €
TF43 NTC20K 250mm	NTC 20K	1101-7011-6051-000	31,22 €
TF43 NTC20K 300mm	NTC 20K	1101-7011-6061-000	32,25 €
TF43 NTC20K 350mm	NTC 20K	1101-7011-6071-000	33,34 €
TF43 NTC20K 400mm	NTC 20K	1101-7011-6081-000	34,20 €
Note	Other sensors optional	on request	
Optional:	Cable connection with <b>M12 connector</b> according to DIN EN 61076-2-101	on request	



Immersion / screw-in / duct temperature sensors  
 with passive output

One basic device in four variants...



**PATENTED**

**TFxx + TH08 -ms/xx**

Immersion / screw-in temperature sensor with immersion sleeve, brass, nickel-plated

**TFxx + TH08 -VA/xx**

Immersion / screw-in temperature sensor with immersion sleeve, stainless steel, V4A

**TFxx + TH08 -VA/xx/90**

Immersion / screw-in temperature sensor with immersion sleeve with neck tube, stainless steel, V4A

**TFxx + MF-15-K**

Duct temperature sensor with mounting flange, plastic

Dimensional drawing TH08 -ms/xx

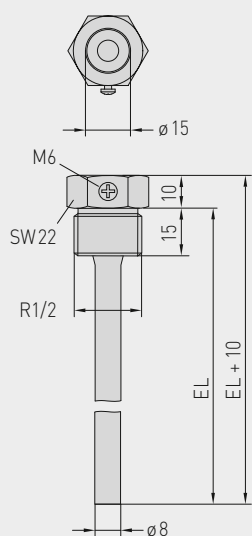

Dimensional drawing TH08 -VA/xx

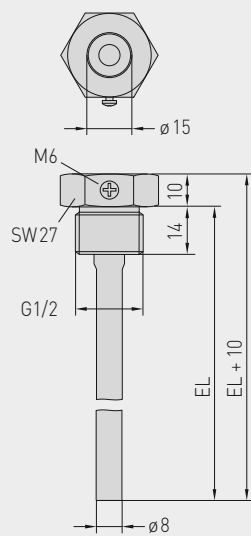

Dimensional drawing TH08 -VA/xx/90

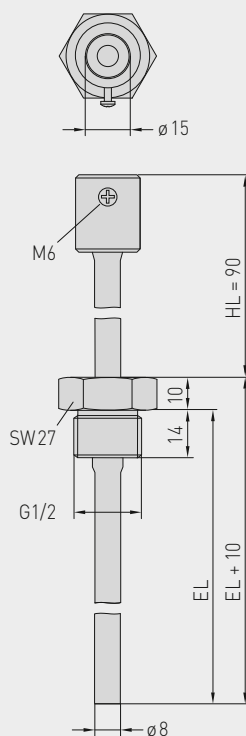

Dimensional drawing MF-15-K

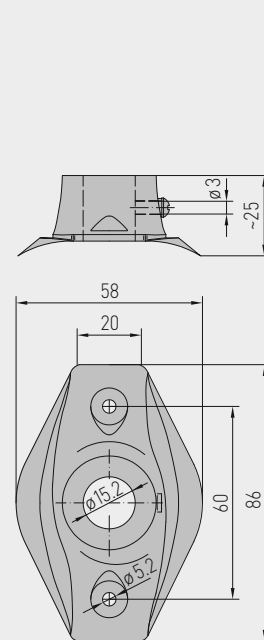





...through combination with accessories:



**TH08-ms/xx**  
Immersion sleeve,  
brass, nickel-plated,  
thread-sealing, conical,  
according to DIN 10226



**TH08-VA/xx**  
Immersion sleeve,  
stainless steel, V4A,  
flat-sealing, cylindrical,  
according to DIN 228



**TH08-VA/xx/90**  
Immersion sleeve with neck tube,  
stainless steel, V4A,  
flat-sealing, cylindrical,  
according to DIN 228



**MF-15-K**  
Mounting flange,  
plastic

THERMASGARD® TH08 Immersion sleeve Ø 8 mm (Accessories)					
Type / WG01B	p <sub>max</sub> (static)	T <sub>max</sub>	Inserted Length (EL)	Item No.	Price
<b>TH08-ms/xx</b> Brass, nickel-plated					
without neck tube					
TH08-MS 50MM	10 bar	+150 °C	50 mm	7100-0011-0010-132	8,87 €
TH08-MS 100MM	10 bar	+150 °C	100 mm	7100-0011-0020-132	10,10 €
TH08-MS 150MM	10 bar	+150 °C	150 mm	7100-0011-0030-132	10,67 €
TH08-MS 200MM	10 bar	+150 °C	200 mm	7100-0011-0040-132	11,01 €
TH08-MS 250MM	10 bar	+150 °C	250 mm	7100-0011-0050-132	12,75 €
TH08-MS 300MM	10 bar	+150 °C	300 mm	7100-0011-0060-132	13,10 €
TH08-MS 350MM	10 bar	+150 °C	350 mm	7100-0011-0070-132	13,21 €
TH08-MS 400MM	10 bar	+150 °C	400 mm	7100-0011-0080-132	13,33 €
<b>TH08-VA/xx</b> Stainless steel, V4A (1.4571)					
without neck tube					
TH08-VA 50MM	40 bar	+600 °C	50 mm	7100-0012-0010-132	19,31 €
TH08-VA 100MM	40 bar	+600 °C	100 mm	7100-0012-0020-132	21,34 €
TH08-VA 150MM	40 bar	+600 °C	150 mm	7100-0012-0030-132	22,93 €
TH08-VA 200MM	40 bar	+600 °C	200 mm	7100-0012-0040-132	24,17 €
TH08-VA 250MM	40 bar	+600 °C	250 mm	7100-0012-0050-132	30,05 €
TH08-VA 300MM	40 bar	+600 °C	300 mm	7100-0012-0060-132	31,40 €
TH08-VA 350MM	40 bar	+600 °C	350 mm	7100-0012-0070-132	31,61 €
TH08-VA 400MM	40 bar	+600 °C	400 mm	7100-0012-0080-132	32,17 €
<b>TH08-VA/xx/90</b> Stainless steel, V4A (1.4571)					
with neck tube (90 mm)					
TH08-VA 50/90MM	40 bar	+600 °C	50 mm	7100-0012-0012-132	27,66 €
TH08-VA 100/90MM	40 bar	+600 °C	100 mm	7100-0012-0022-132	28,90 €
TH08-VA 150/90MM	40 bar	+600 °C	150 mm	7100-0012-0032-132	30,32 €
TH08-VA 200/90MM	40 bar	+600 °C	200 mm	7100-0012-0042-132	31,61 €
TH08-VA 250/90MM	40 bar	+600 °C	250 mm	7100-0012-0052-132	33,13 €
TH08-VA 300/90MM	40 bar	+600 °C	300 mm	7100-0012-0062-132	35,91 €

Note: inner diameter of socket 15.0 mm  
For further information see last chapter!

Mounting flange (Accessories)				
Type / WG01B		T <sub>max</sub>	Item No.	Price
<b>MF</b>				
<b>MF-15-K</b>	Mounting flange, plastic, 56.8x84.3 mm, Ø 15.2 mm tube gland	+100 °C	7100-0032-0000-000	5,83 €

Note: For further information see last chapter!

Flexible sleeve / cable temperature sensors,  
 immersion / screw-in temperature sensors,  
 with passive output

Patented quality product (Immersion sensor patent no. DE 10 2012 017 500.0)

**THERMASGARD® TF 43-F** is a resistance thermometer with a passive output, housing made from impact-resistant plastic with snap-on lid, with sensor sleeve and flexible cable length.

**THERMASGARD® TF 65-F** is a resistance thermometer with a passive output, housing made from impact-resistant plastic with quick-locking screws, with sensor sleeve and flexible cable length.

These built-in temperature sensors / immersion temperature sensors are electric contact thermometers for temperature measurement in liquids and gases, which are installed for example in piping systems and vessels. For aggressive media, stainless steel immersion sleeves must be used. Applications of these temperature sensors in piping systems, in heating technology, in storage tanks, in district heating compact stations, in hot and cold-water systems, in oil and lubricant circulation systems, in mechanical, apparatus and plant engineering as well as in the entire industrial sector.

**TECHNICAL DATA**

Measuring range:	-50...+180 °C
Sensors / output:	see table, passive ( <b>Perfect Sensor Protection</b> ) (optional also with two sensors)
Connection type:	2-wire connection (4-wire connection optional)
Testing current:	< 0.6 mA (Pt1000) < 0.3 mA (Ni1000)
Insulating resistance:	≥ 100 MΩ, at +20 °C (500 V DC)
Ambient temperature:	-20...+100 °C
Housing:	plastic, UV-resistant, material polyamide, 30 % glass-globe reinforced, colour traffic white (similar to RAL 9016) <b>TF 43-F with snap-on lid</b> <b>TF 65-F with quick-locking screws</b> (slotted / Phillips head combination)
Housing dimensions:	72 x 64 x 37.8 mm (Tyr 1 / Tyr 01)
Cable connection:	<b>cable gland</b> , plastic (M 16 x 1.5; with strain relief, exchangeable, max. inner diameter 10.4 mm) <b>or</b> <b>M12 connector</b> according to DIN EN 61076-2-101 (optional on request)
Electrical connection:	0.14 - 1.5 mm <sup>2</sup> , via terminal screws
Connecting cable:	silicone, SiHF, 2 x 0.25 mm <sup>2</sup> , cable length (KL) = flexible, inserted length (EL) > 50 mm
Sensor sleeve:	stainless steel <b>V4A</b> (1.4571), Ø = 6 mm, nominal length = 50 mm
Permissible humidity:	< 95 % r. H., non-precipitating air
Protection class:	III (according to EN 60 730)
Protection type housing:	<b>TF 43-F IP54</b> (according to EN 60 529)* Housing tested, TÜV SÜD, Report No. 713160960A (Tyr 01) <b>TF 65-F IP65</b> (according to EN 60 529)* * Housing in the built-in state
Protection type sensor:	<b>IP65</b> (according to EN 60 529) <b>sleeve</b> humidity-tight (standard) <b>IP68</b> (according to EN 60 529) <b>sleeve</b> water-tight (optional)

**ACCESSORIES**

<b>TH08-ms/xx</b>	<b>Immersion sleeve</b> , brass, nickel-plated, Ø = 8 mm, T <sub>max</sub> = +150 °C, p <sub>max</sub> = 10 bar
<b>TH08-VA/xx</b>	<b>Immersion sleeve</b> , stainless steel, <b>V4A</b> (1.4571), Ø = 8 mm, T <sub>max</sub> = +600 °C, p <sub>max</sub> = 40 bar
<b>TH08-VA/xx/90</b>	<b>Immersion sleeve</b> , stainless steel, <b>V4A</b> (1.4571), with neck tube (90 mm), Ø = 8 mm, T <sub>max</sub> = +600 °C, p <sub>max</sub> = 40 bar

High-performance encapsulation against  
 vibration, mechanical stress and humidity

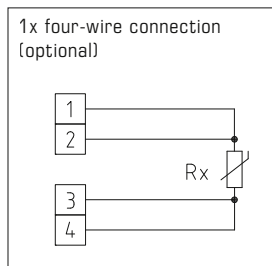
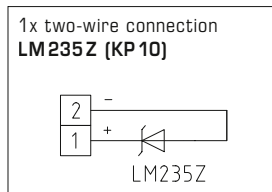
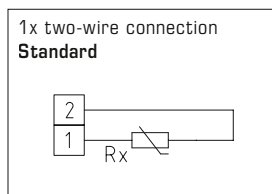

**IP65** (standard)  
 humidity-tight



**IP68** (optional)  
 water-tight  
**Perfect Sensor Protection**



S+S REGELTECHNIK

**THERMASGARD® TF 43-F**  
**THERMASGARD® TF 65-F**

Flexible sleeve / cable temperature sensors,  
immersion / screw-in temperature sensors,  
with passive output

Dimensional drawing

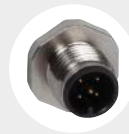
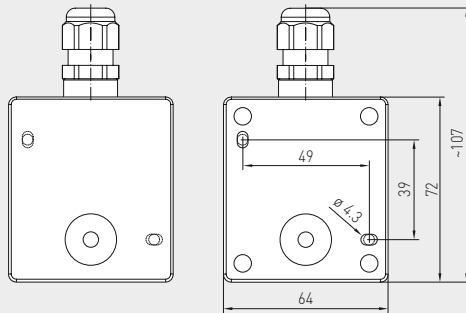

**M12 connector**  
(optional on request)

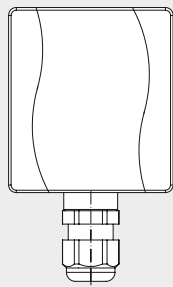
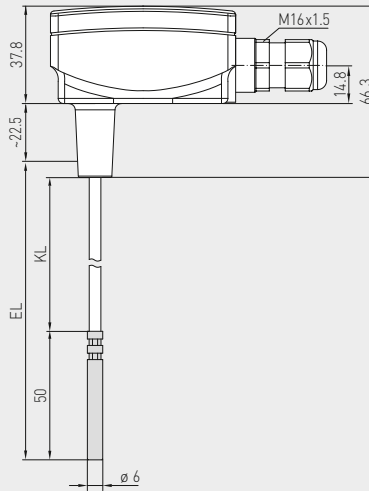
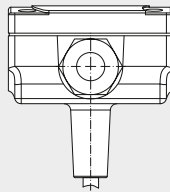

with snap-on lid

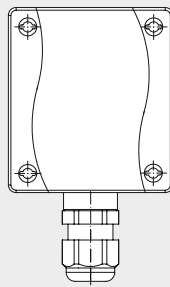

with quick-locking screws

**TF43-F**  
**TF65-F**



**TF43-F**  
with snap-on lid  
(IP54)



**TF65-F**  
with quick-locking screws  
(IP65)

**THERMASGARD® TF 43 F** Flexible cable temperature sensor (basic unit with snap-on lid), *Standard*

Type / WG01 / EL	Sensor / Output	Sensor / Output	Price
<b>TF43-F xx</b>		<b>IP54</b>	
TF43-F Pt1000 250mm	Pt1000 (according to DIN EN 60 751, class B)	1101-3080-5051-000	<b>41,21 €</b>
TF43-F Pt1000 450mm	Pt1000 (according to DIN EN 60 751, class B)	1101-3080-5091-000	<b>42,35 €</b>
TF43-F Ni1000 250mm	Ni1000 (according to DIN EN 43 760, class B, TCR = 6180 ppm / K)	1101-3080-9051-000	<b>43,82 €</b>
TF43-F Ni1000 450mm	Ni1000 (according to DIN EN 43 760, class B, TCR = 6180 ppm / K)	1101-3080-9091-000	<b>44,95 €</b>
Optional:	Cable connection with <b>M12 connector</b> according to DIN EN 61076-2-101	on request	
Note:	<b>flexible cable length (EL &gt; 50 mm)</b>		

**THERMASGARD® TF 65-F** Flexible cable temperature sensor (basic unit with quick-locking screws), *Premium*

Type / WG01 / EL	Sensor / Output	Sensor / Output	Price
<b>TF65-F xx</b>		<b>IP65</b>	
TF65-F Pt1000 250mm	Pt1000 (according to DIN EN 60 751, class B)	1101-3060-5051-000	<b>47,63 €</b>
TF65-F Pt1000 450mm	Pt1000 (according to DIN EN 60 751, class B)	1101-3060-5091-000	<b>48,77 €</b>
TF65-F Ni1000 250mm	Ni1000 (according to DIN EN 43 760, class B, TCR = 6180 ppm / K)	1101-3060-9051-000	<b>50,23 €</b>
TF65-F Ni1000 450mm	Ni1000 (according to DIN EN 43 760, class B, TCR = 6180 ppm / K)	1101-3060-9091-000	<b>51,36 €</b>
Extra charge:	Other sensors and cable lengths optional	on request	
Optional:	Cable connection with <b>M12 connector</b> according to DIN EN 61076-2-101	on request	
Note:	<b>flexible cable length (EL &gt; 50 mm)</b>		

A basic unit with flexible cable length in three variants...



**TFxx-F + TH08-ms/xx**

Immersion / screw-in temperature sensor with immersion sleeve, brass, nickel-plated

**TFxx-F + TH08-VA/xx**

Immersion / screw-in temperature sensor with immersion sleeve, stainless steel, V4A

**TFxx-F + TH08-VA/xx/90**

Immersion / screw-in temperature sensor with immersion sleeve with neck tube, stainless steel, V4A

**TFxx-F Basic unit**

Flexible cable length through cable entry in the housing

Dimensional drawing TH08-ms/xx

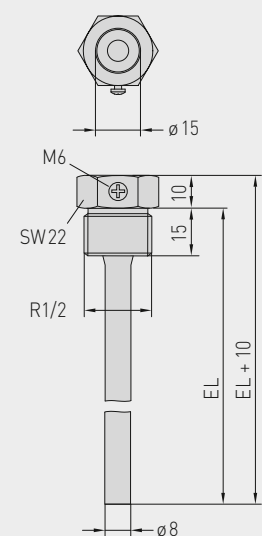

Dimensional drawing TH08-VA/xx

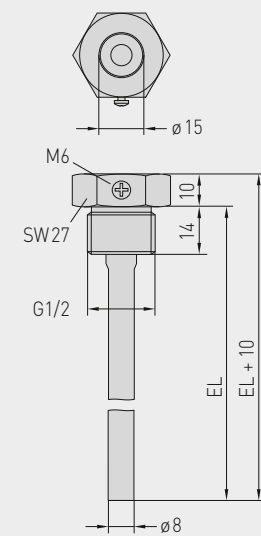

Dimensional drawing TH08-VA/xx/90

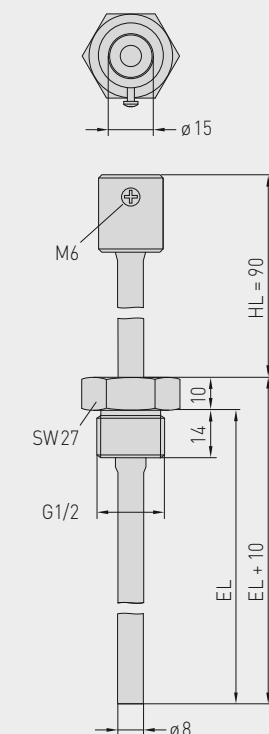





...through combination with accessories:



**TH08-ms/xx**

Immersion sleeve,  
brass, nickel-plated,  
thread-sealing, conical,  
according to DIN 10226



**TH08-VA/xx**

Immersion sleeve,  
stainless steel, V4A,  
flat-sealing, cylindrical,  
according to DIN 228



**TH08-VA/xx/90**

Immersion sleeve with neck tube,  
stainless steel, V4A,  
flat-sealing, cylindrical,  
according to DIN 228

THERMASGARD® TH08 Immersion sleeve Ø 8 mm (Accessories)					
Type / WG01B	p <sub>max</sub> (static)	T <sub>max</sub>	Inserted Length (EL)	Item No.	Price
<b>TH08-ms/xx</b>	<b>Brass, nickel-plated</b>			without neck tube	
TH08-MS 50MM	10 bar	+150 °C	<b>50 mm</b>	7100-0011-0010-132	<b>8,87 €</b>
TH08-MS 100MM	10 bar	+150 °C	<b>100 mm</b>	7100-0011-0020-132	<b>10,10 €</b>
TH08-MS 150MM	10 bar	+150 °C	<b>150 mm</b>	7100-0011-0030-132	<b>10,67 €</b>
TH08-MS 200MM	10 bar	+150 °C	<b>200 mm</b>	7100-0011-0040-132	<b>11,01 €</b>
TH08-MS 250MM	10 bar	+150 °C	<b>250 mm</b>	7100-0011-0050-132	<b>12,75 €</b>
TH08-MS 300MM	10 bar	+150 °C	<b>300 mm</b>	7100-0011-0060-132	<b>13,10 €</b>
TH08-MS 350MM	10 bar	+150 °C	<b>350 mm</b>	7100-0011-0070-132	<b>13,21 €</b>
TH08-MS 400MM	10 bar	+150 °C	<b>400 mm</b>	7100-0011-0080-132	<b>13,33 €</b>
<b>TH08-VA/xx</b>	<b>Stainless steel, V4A (1.4571)</b>			without neck tube	
TH08-VA 50MM	40 bar	+600 °C	<b>50 mm</b>	7100-0012-0010-132	<b>19,31 €</b>
TH08-VA 100MM	40 bar	+600 °C	<b>100 mm</b>	7100-0012-0020-132	<b>21,34 €</b>
TH08-VA 150MM	40 bar	+600 °C	<b>150 mm</b>	7100-0012-0030-132	<b>22,93 €</b>
TH08-VA 200MM	40 bar	+600 °C	<b>200 mm</b>	7100-0012-0040-132	<b>24,17 €</b>
TH08-VA 250MM	40 bar	+600 °C	<b>250 mm</b>	7100-0012-0050-132	<b>30,05 €</b>
TH08-VA 300MM	40 bar	+600 °C	<b>300 mm</b>	7100-0012-0060-132	<b>31,40 €</b>
TH08-VA 350MM	40 bar	+600 °C	<b>350 mm</b>	7100-0012-0070-132	<b>31,61 €</b>
TH08-VA 400MM	40 bar	+600 °C	<b>400 mm</b>	7100-0012-0080-132	<b>32,17 €</b>
<b>TH08-VA/xx/90</b>	<b>Stainless steel, V4A (1.4571)</b>			with neck tube (90 mm)	
TH08-VA 50/90MM	40 bar	+600 °C	<b>50 mm</b>	7100-0012-0012-132	<b>27,66 €</b>
TH08-VA 100/90MM	40 bar	+600 °C	<b>100 mm</b>	7100-0012-0022-132	<b>28,90 €</b>
TH08-VA 150/90MM	40 bar	+600 °C	<b>150 mm</b>	7100-0012-0032-132	<b>30,32 €</b>
TH08-VA 200/90MM	40 bar	+600 °C	<b>200 mm</b>	7100-0012-0042-132	<b>31,61 €</b>
TH08-VA 250/90MM	40 bar	+600 °C	<b>250 mm</b>	7100-0012-0052-132	<b>33,13 €</b>
TH08-VA 300/90MM	40 bar	+600 °C	<b>300 mm</b>	7100-0012-0062-132	<b>35,91 €</b>
Note:	inner diameter of socket 15.0 mm For further information see last chapter!				

**Mean value / rod / duct temperature sensor including mounting flange, with passive output**

Mean-value temperature sensor **THERMASGARD® MWTF** (rod sensor 0.4...20 m) with passive output, in an impact-resistant plastic housing with quick-locking screws, with bendable sensor rod (fully active), protective tube made from copper, plastic-coated, and anti-kink spring, incl. mounting flange.

Mean-value temperature sensor **THERMASGARD® MWTF-SD** (rod sensor 3 m / 6 m) with passive output, in an impact-resistant plastic housing with snap-on lid, with bendable sensor rod (fully active), protective tube made from reinforced thermoplastic hose and anti-kink spring, incl. mounting flange.

The sensor is used to detect the mean temperature (mean value) in gaseous media, e.g. in ventilation and air conditioning ducts over the entire cross section or over a defined length. Laid along a meandering route, it uniformly detects the surrounding temperature, as a duct temperature sensor. For proper mounting of the rod, mounting clamps **MK-05-M** (accessories) are available.

**MWTF**  
 Rod length 0,4 m  
 (IP 65)



**TECHNICAL DATA**

Measuring range:	-30...+80 °C
Sensors / output:	see table, passive
Connection type:	2-wire connection (4-wire connection on PT100, optional on other sensors)
Testing current:	< 0.6 mA (Pt1000) < 1.0 mA (Pt100) < 0.3 mA (Ni1000)
<b>Sensor:</b>	active over the entire length (averaging)
Rod material:	<b>protective tube made from copper, plastic-coated, (MWTF)</b> (made from reinforced thermoplastic hose on the <b>MWTF-SD</b> , with anti-kink spring and sleeve, stainless steel, V4A (1.4571))
Rod dimensions:	Ø = 5.0 mm, nominal length (NL) = 0.4 m / 3 m / 6 m, see table (nominal length optionally up to max. 20 m)
Rod laying:	<b>Observe the admissible values!</b> Bending radius: > 35 mm Vibration load: ≤ 0.5 g Tensile load: < 480 N for the <b>MWTF</b> < 100 N for the <b>MWTF-SD</b>
<b>Housing:</b>	plastic, UV-resistant, material polyamide, 30% glass-globe reinforced, with quick-locking screws (slotted / Phillips head combination), colour traffic white (similar to RAL 9016)
Housing dimensions:	72 x 64 x 37.8 mm (Tyr 1)
Cable connection:	<b>cable gland</b> , plastic (M 16 x 1.5; with strain relief, exchangeable, max. inner diameter 10.4 mm) <b>or</b> <b>M12 connector</b> according to DIN EN 61076-2-101 (optional on request)
Electrical connection:	0.14 - 1.5 mm <sup>2</sup> via terminal screws
Process connection:	by mounting flange, plastic, (galvanised steel optional, see accessories) and mounting clamps <b>MK-05-M</b>
Ambient temperature:	-20...+80 °C
Humidity:	< 95% r. H., non-precipitating air
Protection class:	III (according to EN 60 730)
Protection type:	<b>IP 54</b> (according to EN 60 529) for the <b>MWTF-SD</b> <b>IP 65</b> (according to EN 60 529) for the <b>MWTF</b> Housing tested, TÜV SÜD, report no. 713139052 (Tyr 1)
<b>ACCESSORIES</b>	see table

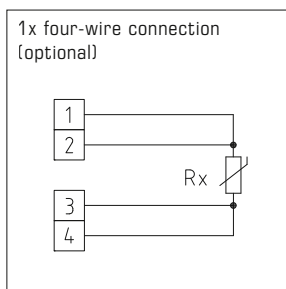
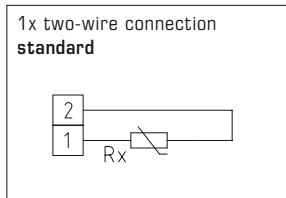

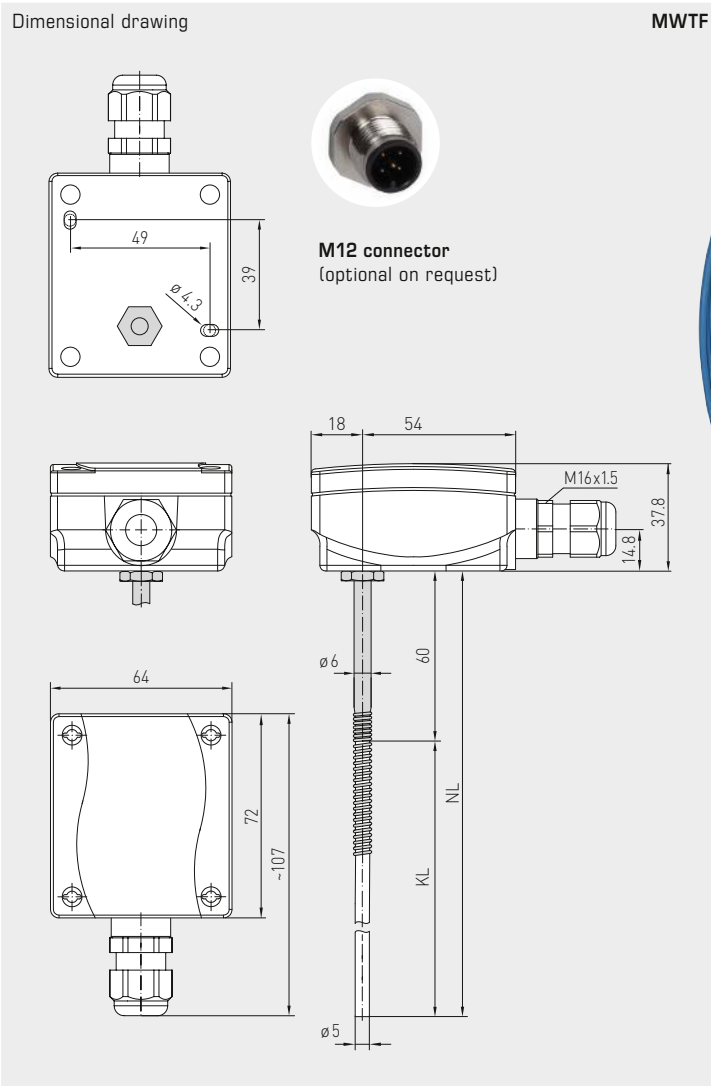
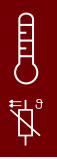

MWTF  
Rod length 3 m / 6 m  
(IP65)



MWTF-SD  
Rod length 3 m / 6 m  
(IP54)



Mean value / rod / duct temperature sensor  
including mounting flange, with passive output

**MWTF**  
Rod length 0,4 m  
(IP 65)

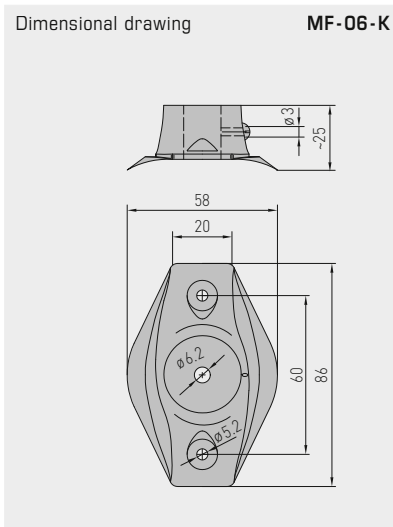
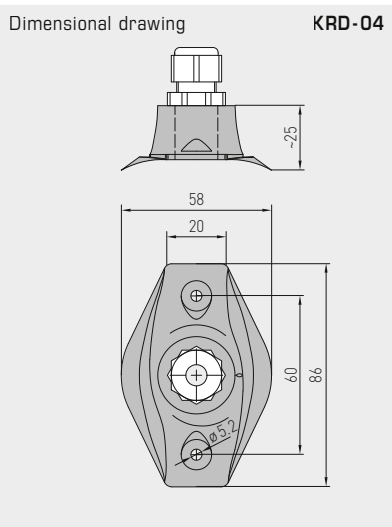

**MF-06-K**  
Mounting flange,  
plastic  
(Included in the  
scope of delivery)



**KRD-04**  
Capillary tube  
bushing, plastic  
(optional)

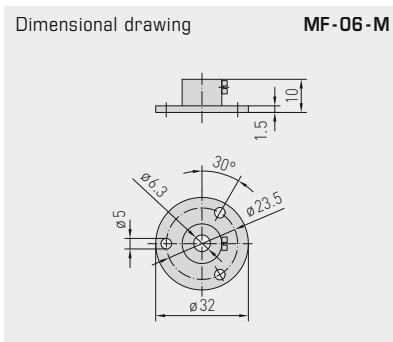
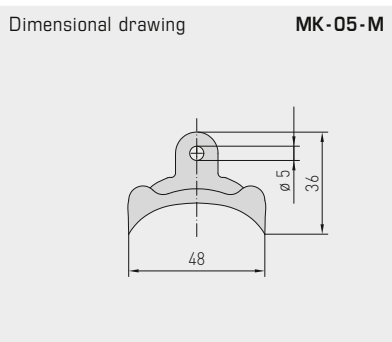

**MF-06-M**  
Mounting flange,  
metal  
(optional)



**MK-05-M**  
Mounting clamps,  
galvanised steel  
(from 3 m rod length,  
included in the scope  
of delivery)







THERMASGARD® MWTF-SD		Mean-value temperature sensor with rod made from reinforced thermoplastic hose, <i>Standard</i>		
Type / WG03B	Sensor / Output	Rod length	Item No.	Price
<b>MWTF-SD</b>	<b>Pt1000</b>		<b>IP54</b>	
MWTF-SD Pt1000 3m	Pt1000 (according to DIN EN 60 751, class B)	<b>3.0 m</b>	1101-3050-5231-200	<b>90,12 €</b>
MWTF-SD Pt1000 6m	Pt1000 (according to DIN EN 60 751, class B)	<b>6.0 m</b>	1101-3050-5261-200	<b>100,27 €</b>
Optional:	Cable connection with <b>M12 connector</b> according to DIN EN 61076-2-101		on request	

THERMASGARD® MWTF		Mean-value temperature sensor with rod made from copper, plastic-coated, <i>Premium</i>		
Type / WG03	Sensor / Output	Rod length	Item No.	Price
<b>MWTF</b>	<b>Pt100</b>		<b>IP65</b>	
MWTF Pt100 0,4m	Pt100 (according to DIN EN 60 751, class B)	<b>0.4 m</b>	1101-3050-1083-000	<b>78,82 €</b>
MWTF Pt100 3m	Pt100 (according to DIN EN 60 751, class B)	<b>3.0 m</b>	1101-3050-1233-000	<b>138,21 €</b>
MWTF Pt100 6m	Pt100 (according to DIN EN 60 751, class B)	<b>6.0 m</b>	1101-3050-1263-000	<b>185,51 €</b>
<b>MWTF</b>	<b>Pt1000</b>		<b>IP65</b>	
MWTF Pt1000 0,4m	Pt1000 (according to DIN EN 60 751, class B)	<b>0.4 m</b>	1101-3050-5081-000	<b>78,82 €</b>
MWTF Pt1000 3m	Pt1000 (according to DIN EN 60 751, class B)	<b>3.0 m</b>	1101-3050-5231-000	<b>138,21 €</b>
MWTF Pt1000 6m	Pt1000 (according to DIN EN 60 751, class B)	<b>6.0 m</b>	1101-3050-5261-000	<b>185,51 €</b>
<b>MWTF</b>	<b>Ni1000</b>		<b>IP65</b>	
MWTF Ni1000 0,4m	Ni1000 (according to DIN EN 43 760, class B)	<b>0.4 m</b>	1101-3050-9081-000	<b>78,82 €</b>
MWTF Ni1000 3m	Ni1000 (according to DIN EN 43 760, class B)	<b>3.0 m</b>	1101-3050-9231-000	<b>144,89 €</b>
MWTF Ni1000 6m	Ni1000 (according to DIN EN 43 760, class B)	<b>6.0 m</b>	1101-3050-9261-000	<b>185,51 €</b>
Extra charge:	Per meter sensor cable (from 6 m to max. 20 m)		on request	
Optional:	Cable connection with <b>M12 connector</b> according to DIN EN 61076-2-101		on request	

ACCESSORIES			
<b>MF-06-K</b>	<b>Mounting flange, plastic</b> (included in the scope of delivery)	7100-0030-1000-000	<b>5,83 €</b>
<b>MF-06-M</b>	<b>Mounting flange, metal, galvanised steel, Ø = 35 mm</b>	7100-0030-5000-100	<b>9,10 €</b>
<b>KRD-04</b>	<b>Capillary tube gland bracket, plastic</b>	7100-0030-7000-000	<b>8,49 €</b>
<b>MK-05-M</b>	<b>Mounting clamps, galvanised steel (6 pieces)</b> (from 3 m rod length, included in the scope of delivery)	7100-0034-0000-000	<b>9,41 €</b>

For further information see last chapter!

**Screw-in/immersion temperature sensors  
with neck tube (stepped once)  
with passive output**

Very quickly responding screw-in resistance thermometer/immersion temperature sensor **THERMASGARD® ETF 7** with passive output, neck tube and a single-tapered stainless steel protective tube, housing cover with quick-locking screws, very short reaction time, particularly suitable for very quick temperature changes and control operations, e.g. in hydraulic systems.

ETF 7

**TECHNICAL DATA**

Measuring range:	-35...+150 °C
Sensors / output:	see table, passive <b>(Perfect Sensor Protection)</b>
Response times:	$t_{0,5} = 2.8$ s $t_{0,9} = 10$ s (for water at a flow rate of 2 m/s)
Connection type:	2-wire connection (4-wire connection on PT100, optional on other sensors)
Testing current:	< 0.6 mA (Pt1000) < 1.0 mA (Pt100) < 0.3 mA (Ni1000, Ni1000 TK5000)
Insulating resistance:	≥ 100 MΩ, at +20 °C (500 V DC)
Electrical connection:	0.14 - 1.5 mm² via terminal screws
Cable connection:	<b>cable gland</b> , plastic (M 16 x 1.5; with strain relief, exchangeable, inner diameter 10.4 mm) <b>or</b> <b>M12 connector</b> according to DIN EN 61076-2-101
Housing:	plastic, UV-resistant, material polyamide, 30% glass-globe reinforced, with quick-locking screws (slotted / Phillips head combination), colour traffic white (similar to RAL 9016)
Housing dimensions:	72 x 64 x 37.8 mm (Tyr 1)
Protective tube:	stainless steel <b>V4A</b> (1.4571), G ½" straight pipe thread, wrench size 27 mm, $p_{max} = 6$ bar, $\varnothing = 6$ mm, single-tapered to $\varnothing = 4$ mm (see dimensional drawing) length of neck tube (HL) = 25 mm inserted length (EL) = 100 - 250 mm (see table)
Process connection:	screwed socket with G ½" straight pipe thread
Humidity:	< 95% r. H., non-precipitating air
Protection class:	III (according to EN 60 730)
Protection type:	<b>IP65</b> (according to EN 60 529) Housing tested, TÜV SÜD, Report No. 713139052 (Tyr 1)



1x two-wire connection  
**standard**

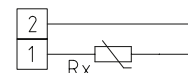

1x two-wire connection  
**LM235Z (KP 10)**

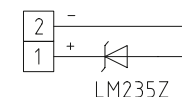

1x four-wire connection  
(optional)

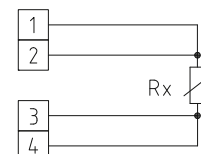

High-performance encapsulation against  
vibration, mechanical stress and humidity

**PS-PROTECTION**  
PERFECT SENSOR PROTECTION

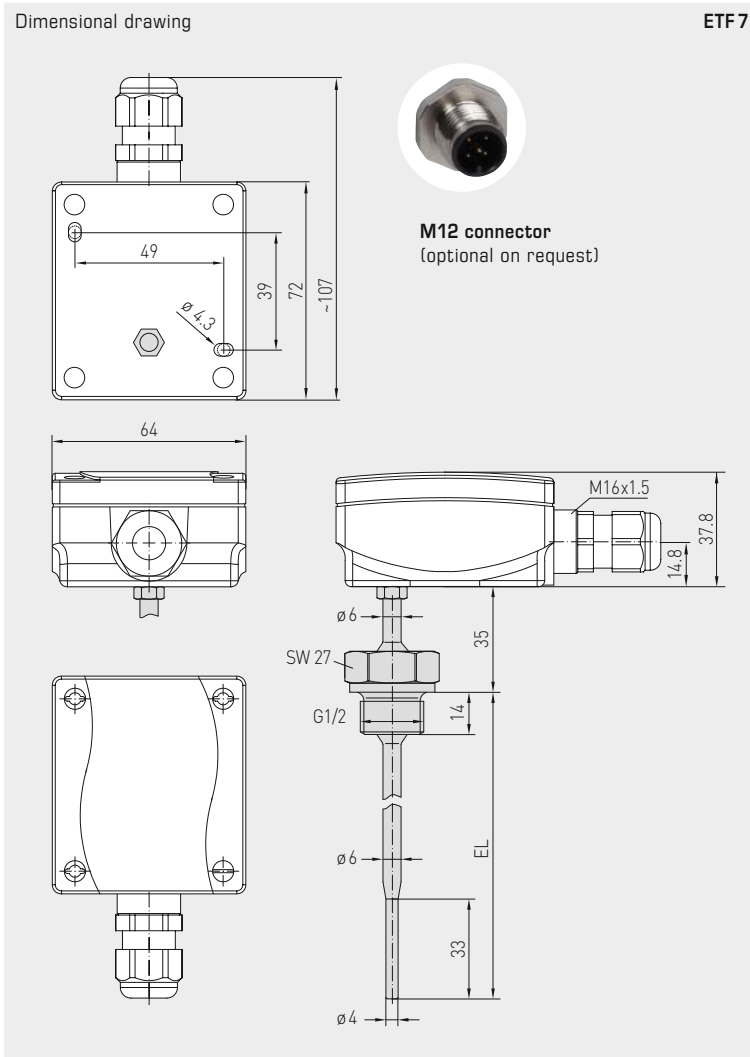
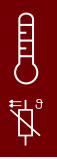

ETF 7

THERMASGARD® ETF 7		Screw-in / immersion temperature sensor with neck tube	
Type / WG01	Sensor / Output	Item No.	Price
<b>ETF7 Pt100 xx</b>	<b>Pt100</b>		
ETF7 Pt100 100mm	Pt100 (according to DIN EN 60 751, class B)	1101-2080-1023-000	<b>135,91 €</b>
ETF7 Pt100 150mm	Pt100 (according to DIN EN 60 751, class B)	1101-2080-1033-000	<b>137,26 €</b>
ETF7 Pt100 250mm	Pt100 (according to DIN EN 60 751, class B)	1101-2080-1053-000	<b>140,39 €</b>
<b>ETF7 Pt1000 xx</b>	<b>Pt1000</b>		
ETF7 Pt1000 100mm	Pt1000 (according to DIN EN 60 751, class B)	1101-2080-5021-000	<b>137,37 €</b>
ETF7 Pt1000 150mm	Pt1000 (according to DIN EN 60 751, class B)	1101-2080-5031-000	<b>138,27 €</b>
ETF7 Pt1000 250mm	Pt1000 (according to DIN EN 60 751, class B)	1101-2080-5051-000	<b>141,06 €</b>
<b>ETF7 Ni1000 xx</b>	<b>Ni1000</b>		
ETF7 Ni1000 100mm	Ni1000 (according to DIN EN 43 760, class B, TCR = 6180 ppm / K)	1101-2084-2021-000	<b>151,50 €</b>
ETF7 Ni1000 150mm	Ni1000 (according to DIN EN 43 760, class B, TCR = 6180 ppm / K)	1101-2084-2031-000	<b>152,96 €</b>
ETF7 Ni1000 250mm	Ni1000 (according to DIN EN 43 760, class B, TCR = 6180 ppm / K)	1101-2084-2051-000	<b>154,88 €</b>
<b>ETF7 Ni1000TK xx</b>	<b>Ni1000 TK5000</b>		
ETF7 NiTK 100mm	Ni1000 TK5000 (TCR = 5000 ppm / K), LG - Ni1000	1101-2081-0021-000	<b>142,81 €</b>
ETF7 NiTK 150mm	Ni1000 TK5000 (TCR = 5000 ppm / K), LG - Ni1000	1101-2081-0031-000	<b>143,19 €</b>
ETF7 NiTK 250mm	Ni1000 TK5000 (TCR = 5000 ppm / K), LG - Ni1000	1101-2081-0051-000	<b>144,51 €</b>
Optional:	Cable connection with <b>M12 connector</b> according to DIN EN 61076-2-101	on request	

**Immersion / screw-in / duct temperature sensor,  
with passive output**

**TF 54**  
Basic unit

Resistance thermometer / temperature sensor **THERMASGARD® TF 54** with passive output, with connecting head made from aluminium (optionally with **cable gland** or **M12 connector** according to DIN EN 61076-2-101) and straight protective tube.

A basic unit in four variants through combination with accessories, eg, for robust applications with a separate immersion sleeve made from stainless steel.

The duct sensor is used to detect temperatures in liquid or gaseous media. It is used in pipes, heating engineering, storage systems, compact district heating stations, warm and cold water systems, oil and lubrication cycle systems, mechanical, apparatus and plant engineering and throughout the industrial sector.



**TECHNICAL DATA**

Measuring range:	-35...+180 °C ( $T_{max}$ NTC = +150 °C, $T_{max}$ LM235Z = +125 °C)
Sensors / output:	see table, passive <b>(Perfect Sensor Protection)</b> (optionally also with two or other sensors)
Connection type:	2-wire connection (4-wire connection on PT100, optional on other sensors)
Testing current:	< 0.6 mA (Pt1000) < 1.0 mA (Pt100) < 0.3 mA (Ni1000, Ni1000 TK5000) < 2.0 mW (NTC xx) 400 µA...5 mA (LM235Z)
Insulating resistance:	≥ 100 MΩ, at +20 °C (500 V DC)
Electrical connection:	0.14 - 2.5 mm <sup>2</sup> , via terminal screws on ceramic bas
Cable connection:	<b>TF 54</b> (standard) adjusting screw made of metal (M20 x 1,5) <b>TF 54-KV</b> (optional) cable gland, brass, nickel-plated (M20 x 1.5; with strain relief, exchangeable, inner diameter 6 - 12 mm) <b>TF 54-Q</b> (optional) M12 connector according to DIN EN 61076-2-101 (male, 5-pin, A-code)
Dimensions:	see dimensional drawing
Connecting head:	form B, material aluminium, colour white aluminium (similar RAL 9006), ambient temperature -20...+100 °C
Protective tube:	stainless steel, V4A (1.4571), Ø = 6 mm, inserted length (EL) = 50 - 400 mm (see table)
Process connection:	by means of immersion sleeve or mounting flange (accessories)
Humidity:	< 95 % r. H., non-precipitating air
Protection class:	III (according to EN 60 730)
Protection type:	<b>IP 54</b> (according to EN 60 529) <b>TF 54</b> <b>IP 65</b> (according to EN 60 529) <b>TF 54-KV / TF 54-Q</b>
<b>ACCESSORIES</b>	(see table)
<b>TH-ms / xx</b>	<b>Immersion sleeve, brass, nickel-plated,</b> Ø = 8 mm, $T_{max}$ = +150 °C, $p_{max}$ = 10 bar
<b>TH-VA / xx</b>	<b>Immersion sleeve, stainless steel, V4A (1.4571),</b> Ø = 8 mm, $T_{max}$ = +600 °C, $p_{max}$ = 40 bar
<b>TH-VA / xx / 90</b>	<b>Immersion sleeve, stainless steel, V4A (1.4571),</b> with neck tube (90 mm), Ø = 8 mm, $T_{max}$ = +600 °C, $p_{max}$ = 40 bar
<b>MF-06-M</b>	<b>Mounting flange, metal, galvanised steel, Ø = 32 mm,</b> Ø = 6.3 mm tube gland, $T_{max}$ = +700 °C



2-wire connection



4-wire connection



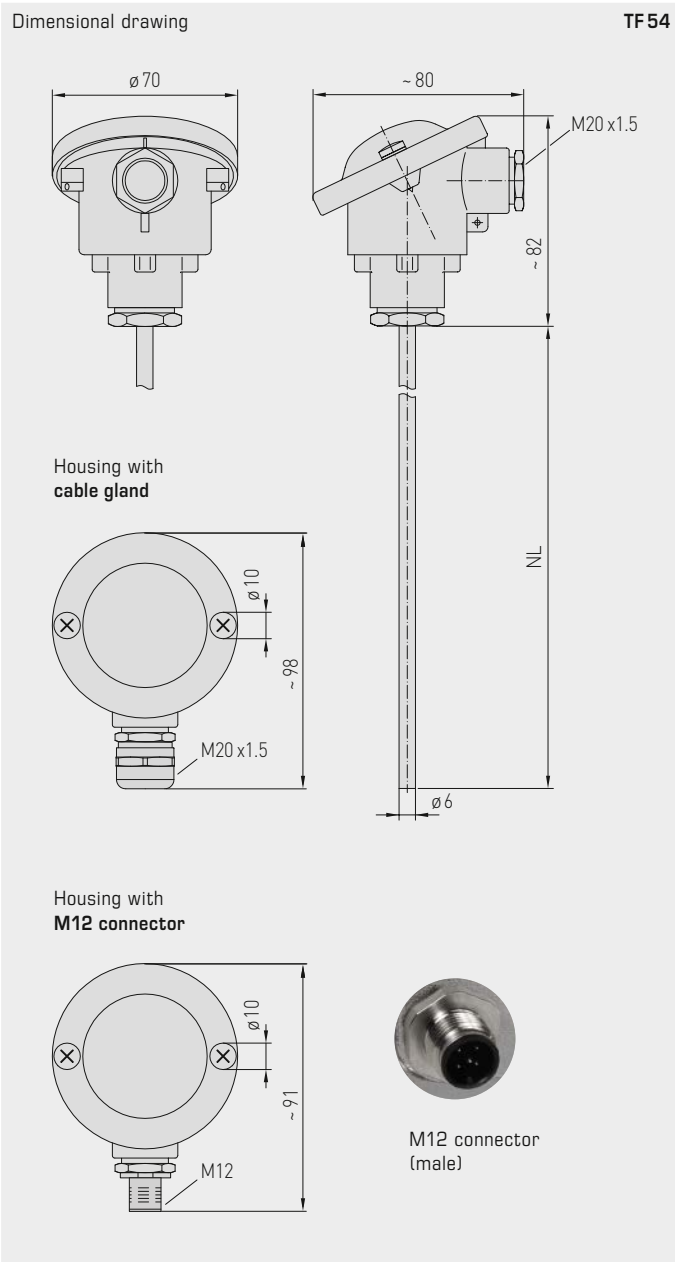
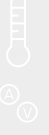

TF 54  
Standard  
(IP 54)



TF 54-KV  
with cable gland  
(IP 65)



TF 54-Q  
with M12 connector  
(IP 65)



High-performance encapsulation against vibration, mechanical stress and humidity



Immersion / screw-in / duct temperature sensor,  
with passive output

**TM54**  
standard  
(IP 54)

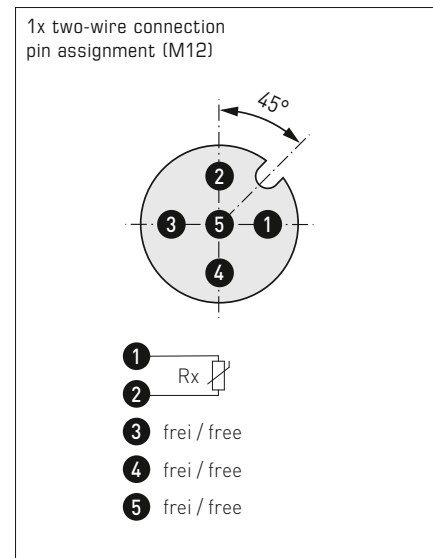
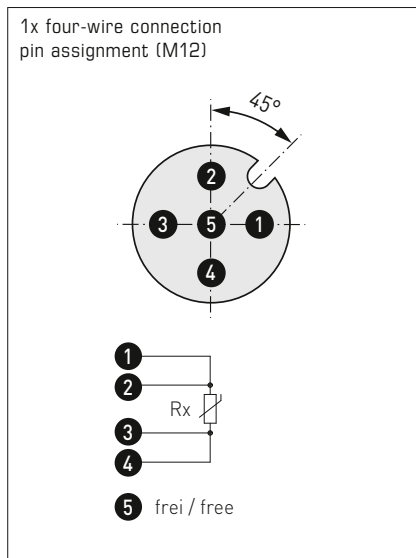
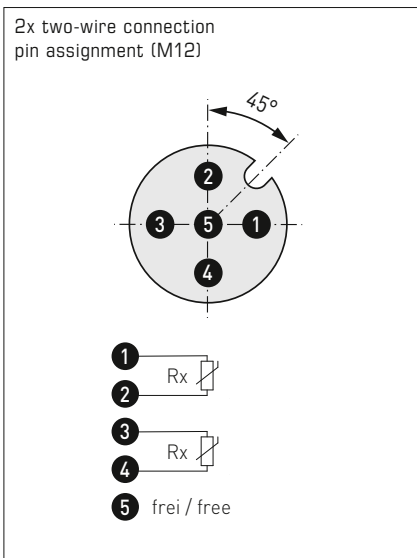
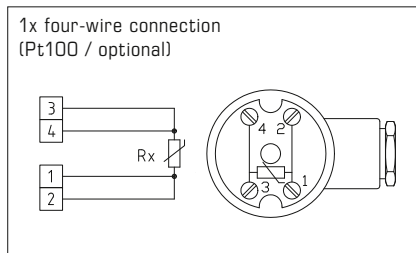
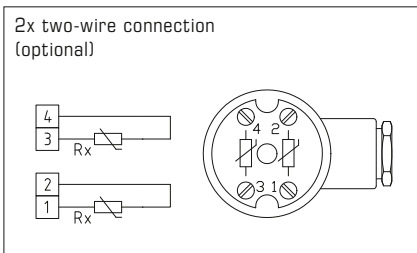
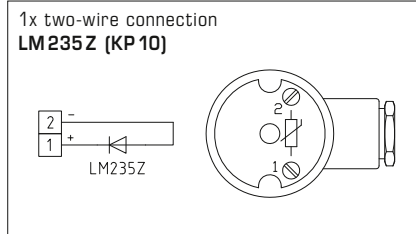
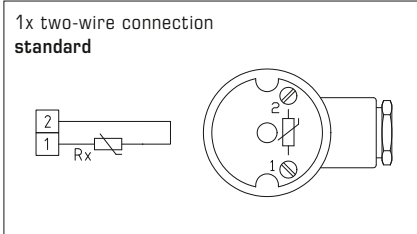

**THERMASGARD®** Temperature sensor  
**TF 54** (Basic unit)

Type / WG03	Sensor / Output	Installation length (EL)	Item No.	Price
<b>TF 54 Pt100 xx</b>	<b>Pt100</b> (according to DIN EN 60751, class B)		<b>IP 54, 4-wire</b>	
TF54 Pt100 50mm	Pt100	50 mm	1101-7050-1013-000	63,22 €
TF54 Pt100 100mm	Pt100	100 mm	1101-7050-1023-000	64,75 €
TF54 Pt100 150mm	Pt100	150 mm	1101-7050-1033-000	66,14 €
TF54 Pt100 200mm	Pt100	200 mm	1101-7050-1043-000	68,69 €
TF54 Pt100 250mm	Pt100	250 mm	1101-7050-1053-000	68,98 €
TF54 Pt100 300mm	Pt100	300 mm	1101-7050-1063-000	69,23 €
TF54 Pt100 400mm	Pt100	400 mm	1101-7050-1083-000	70,19 €
<b>TF 54 Pt1000 xx</b>	<b>Pt1000</b> (according to DIN EN 60751, class B)		<b>IP 54, 2-wire</b>	
TF54 Pt1000 50mm	Pt1000	50 mm	1101-7050-5011-000	63,22 €
TF54 Pt1000 100mm	Pt1000	100 mm	1101-7050-5021-000	64,75 €
TF54 Pt1000 150mm	Pt1000	150 mm	1101-7050-5031-000	66,14 €
TF54 Pt1000 200mm	Pt1000	200 mm	1101-7050-5041-000	68,69 €
TF54 Pt1000 250mm	Pt1000	250 mm	1101-7050-5051-000	69,04 €
TF54 Pt1000 300mm	Pt1000	300 mm	1101-7050-5061-000	69,23 €
TF54 Pt1000 400mm	Pt1000	400 mm	1101-7050-5081-000	70,19 €

Continued on next page...



THERMASGARD® TF 54		Temperature sensor (Basic unit)		
Type/WG03	Sensor/Output	Installation length (EL)	Item No.	Price
<b>TF 54 Ni1000 xx</b>	<b>Ni 1000</b> (according to DIN EN 43760, class B, TCR = 6180 ppm/K)		<b>IP 54, 2-wire</b>	
TF54 Ni1000 50mm	Ni1000	50 mm	1101-7050-9011-000	64,31 €
TF54 Ni1000 100mm	Ni1000	100 mm	1101-7050-9021-000	66,15 €
TF54 Ni1000 150mm	Ni1000	150 mm	1101-7050-9031-000	67,22 €
TF54 Ni1000 200mm	Ni1000	200 mm	1101-7050-9041-000	68,74 €
TF54 Ni1000 250mm	Ni1000	250 mm	1101-7050-9051-000	69,17 €
TF54 Ni1000 300mm	Ni1000	300 mm	1101-7050-9061-000	69,42 €
TF54 Ni1000 400mm	Ni1000	400 mm	1101-7050-9081-000	70,45 €
<b>TF 54 Ni1000TK xx</b>	<b>Ni1000 TK5000</b> (TCR = 5000 ppm/K), LG-Ni1000		<b>IP 54, 2-wire</b>	
TF54 NiTK 50mm	Ni1000 TK5000	50 mm	1101-7051-0011-000	64,57 €
TF54 NiTK 100mm	Ni1000 TK5000	100 mm	1101-7051-0021-000	66,93 €
TF54 NiTK 150mm	Ni1000 TK5000	150 mm	1101-7051-0031-000	68,05 €
TF54 NiTK 200mm	Ni1000 TK5000	200 mm	1101-7051-0041-000	68,99 €
TF54 NiTK 250mm	Ni1000 TK5000	250 mm	1101-7051-0051-000	69,42 €
TF54 NiTK 300mm	Ni1000 TK5000	300 mm	1101-7051-0061-000	69,64 €
TF54 NiTK 400mm	Ni1000 TK5000	400 mm	1101-7051-0081-000	70,69 €
<b>TF 54 LM235Z xx</b>	<b>LM235Z</b> (TCR = 10 mV/K; 2.73 V at 0°C), KP10		<b>IP 54, 2-wire</b>	
TF54 LM235Z 50mm	LM235Z	50 mm	1101-7052-1011-000	64,52 €
TF54 LM235Z 100mm	LM235Z	100 mm	1101-7052-1021-000	64,93 €
TF54 LM235Z 150mm	LM235Z	150 mm	1101-7052-1031-000	65,05 €
TF54 LM235Z 200mm	LM235Z	200 mm	1101-7052-1041-000	65,78 €
TF54 LM235Z 250mm	LM235Z	250 mm	1101-7052-1051-000	67,48 €
TF54 LM235Z 300mm	LM235Z	300 mm	1101-7052-1061-000	68,03 €
TF54 LM235Z 400mm	LM235Z	400 mm	1101-7052-1081-000	69,17 €
<b>TF 54 NTC 1,8K xx</b>	<b>NTC 1,8K</b>		<b>IP 54, 2-wire</b>	
TF54 NTC1,8K 50mm	NTC 1,8K	50 mm	1101-7051-2011-000	64,21 €
TF54 NTC1,8K 100mm	NTC 1,8K	100 mm	1101-7051-2021-000	68,03 €
TF54 NTC1,8K 150mm	NTC 1,8K	150 mm	1101-7051-2031-000	68,37 €
TF54 NTC1,8K 200mm	NTC 1,8K	200 mm	1101-7051-2041-000	68,86 €
TF54 NTC1,8K 250mm	NTC 1,8K	250 mm	1101-7051-2051-000	70,02 €
TF54 NTC1,8K 300mm	NTC 1,8K	300 mm	1101-7051-2061-000	70,69 €
TF54 NTC1,8K 400mm	NTC 1,8K	400 mm	1101-7051-2081-000	70,95 €
<b>TF 54 NTC10K xx</b>	<b>NTC 10K</b>		<b>IP 54, 2-wire</b>	
TF54 NTC10K 50mm	NTC 10K	50 mm	1101-7051-5011-000	64,21 €
TF54 NTC10K 100mm	NTC 10K	100 mm	1101-7051-5021-000	68,03 €
TF54 NTC10K 150mm	NTC 10K	150 mm	1101-7051-5031-000	68,37 €
TF54 NTC10K 200mm	NTC 10K	200 mm	1101-7051-5041-000	68,86 €
TF54 NTC10K 250mm	NTC 10K	250 mm	1101-7051-5051-000	70,02 €
TF54 NTC10K 300mm	NTC 10K	300 mm	1101-7051-5061-000	70,69 €
TF54 NTC10K 400mm	NTC 10K	400 mm	1101-7051-5081-000	70,95 €
<b>TF 54 NTC20K xx</b>	<b>NTC 20K</b>		<b>IP 54, 2-wire</b>	
TF54 NTC20K 50mm	NTC 20K	50 mm	1101-7051-6011-000	64,21 €
TF54 NTC20K 100mm	NTC 20K	100 mm	1101-7051-6021-000	68,03 €
TF54 NTC20K 150mm	NTC 20K	150 mm	1101-7051-6031-000	68,37 €
TF54 NTC20K 200mm	NTC 20K	200 mm	1101-7051-6041-000	68,86 €
TF54 NTC20K 250mm	NTC 20K	250 mm	1101-7051-6051-000	70,02 €
TF54 NTC20K 300mm	NTC 20K	300 mm	1101-7051-6061-000	70,69 €
TF54 NTC20K 400mm	NTC 20K	400 mm	1101-7051-6081-000	70,95 €
<b>Housing variant:</b>	equipped as standard with pressure screw (IP 54), optional housing variants with cable gland (IP 65) or M12 connector (IP 65) see the next page!			
Extra charge:	optionally also with two or other sensors		on request	

Immersion/screw-in/duct temperature sensor,  
with passive output

**TF 54 - Q**  
with M12 connector  
(IP 65)



THERMASGARD®		Temperature sensor (Basic unit with M12 connector)			
Type/WG03	Sensor/Output	Installation length (EL)	Q	Item No.	Price
<b>TF 54 Pt100 xx Q</b>	<b>Pt100</b> (according to DIN EN 60751, class B)		●	<b>IP 65, 4-wire</b>	
TF54 Pt100 50mm Q	Pt100	50 mm	●	2Z01-4111-0100-011	103,14 €
TF54 Pt100 100mm Q	Pt100	100 mm	●	2Z01-4111-0100-021	104,67 €
TF54 Pt100 150mm Q	Pt100	150 mm	●	2Z01-4111-0100-031	106,08 €
TF54 Pt100 200mm Q	Pt100	200 mm	●	2Z01-4111-0100-041	108,60 €
TF54 Pt100 250mm Q	Pt100	250 mm	●	2Z01-4111-0100-051	108,91 €
TF54 Pt100 300mm Q	Pt100	300 mm	●	2Z01-4111-0100-061	109,16 €
TF54 Pt100 400mm Q	Pt100	400 mm	●	2Z01-4111-0100-081	110,13 €
<b>TF 54 Pt1000 xx Q</b>	<b>Pt1000</b> (according to DIN EN 60751, class B)		●	<b>IP 65, 2-wire</b>	
TF54 Pt1000 50mm Q	Pt1000	50 mm	●	2Z05-4111-0100-011	103,14 €
TF54 Pt1000 100mm Q	Pt1000	100 mm	●	2Z05-4111-0100-021	104,67 €
TF54 Pt1000 150mm Q	Pt1000	150 mm	●	2Z05-4111-0100-031	106,08 €
TF54 Pt1000 200mm Q	Pt1000	200 mm	●	2Z05-4111-0100-041	108,60 €
TF54 Pt1000 250mm Q	Pt1000	250 mm	●	2Z05-4111-0100-051	108,91 €
TF54 Pt1000 300mm Q	Pt1000	300 mm	●	2Z05-4111-0100-061	109,16 €
TF54 Pt1000 400mm Q	Pt1000	400 mm	●	2Z05-4111-0100-081	110,13 €
<b>Housing variant "Q":</b>	Cable connection with M12 connector (male, 5-pin, A-code)				
Extra charge:	optionally also with two or other sensors			on request	

**ACCESSORIES**

Special accessories for M12 connector  
see chapter Accessories!



Immersion / screw-in / duct temperature sensor,  
with passive outputTF54 - KV  
with cable gland  
(IP 65)**THERMASGARD®** Temperature sensor  
**TF 54 - KV** (Basic unit with cable gland)

Type / WG03	Sensor / Output	Installation length (EL)	Item No.	Price
<b>TF54 Pt100 xx KV</b>	<b>Pt100</b> (according to DIN EN 60751, class B)		<b>IP65, 4-wire</b>	
TF54 Pt100 50mm KV	Pt100	50 mm	1101-7070-1013-000	72,20 €
TF54 Pt100 100mm KV	Pt100	100 mm	1101-7070-1023-000	73,72 €
TF54 Pt100 150mm KV	Pt100	150 mm	1101-7070-1033-000	75,11 €
TF54 Pt100 200mm KV	Pt100	200 mm	1101-7070-1043-000	74,55 €
TF54 Pt100 250mm KV	Pt100	250 mm	1101-7070-1053-000	77,97 €
TF54 Pt100 300mm KV	Pt100	300 mm	1101-7070-1063-000	78,20 €
TF54 Pt100 400mm KV	Pt100	400 mm	1101-7070-1083-000	79,19 €
<b>TF54 Pt1000 xx KV</b>	<b>Pt1000</b> (according to DIN EN 60751, class B)		<b>IP65, 2-wire</b>	
TF54 Pt1000 50mm KV	Pt1000	50 mm	1101-7070-5011-000	72,21 €
TF54 Pt1000 100mm KV	Pt1000	100 mm	1101-7070-5021-000	73,72 €
TF54 Pt1000 150mm KV	Pt1000	150 mm	1101-7070-5031-000	72,03 €
TF54 Pt1000 200mm KV	Pt1000	200 mm	1101-7070-5041-000	77,67 €
TF54 Pt1000 250mm KV	Pt1000	250 mm	1101-7070-5051-000	77,98 €
TF54 Pt1000 300mm KV	Pt1000	300 mm	1101-7070-5061-000	75,30 €
TF54 Pt1000 400mm KV	Pt1000	400 mm	1101-7070-5081-000	79,19 €
<b>Housing variant "KV":</b>	<b>Cable connection with cable gland</b>			
Extra charge:	optionally also with two or other sensors			on request

Immersion / screw-in / duct temperature sensor,  
with passive output

One basic device in four variants ...



**TF 54 +  
TH -ms/xx**

Immersion / screw-in  
temperature sensor  
with immersion sleeve,  
brass, nickel-plated

**TF 54 +  
TH -VA/xx**

Immersion / screw-in  
temperature sensor  
with immersion sleeve,  
stainless steel, V4A

**TF 54 +  
TH -VA/xx/90**

Immersion / screw-in  
temperature sensor with  
immersion sleeve with  
neck tube, stainless steel, V4A

**TF 54 +  
MF-06-M**

Duct temperature sensor  
with mounting flange, metal

**Dimensional drawing  
TH -ms/xx**

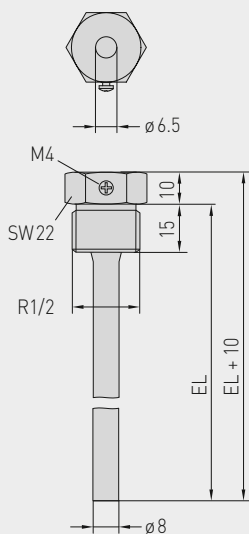

**Dimensional drawing  
TH -VA/xx**

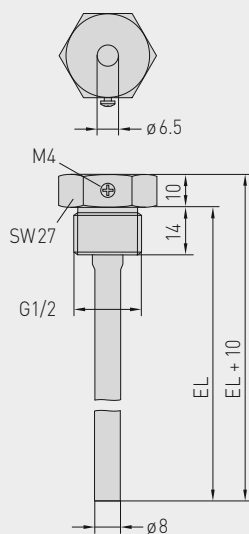

**Dimensional drawing  
TH -VA/xx/90**

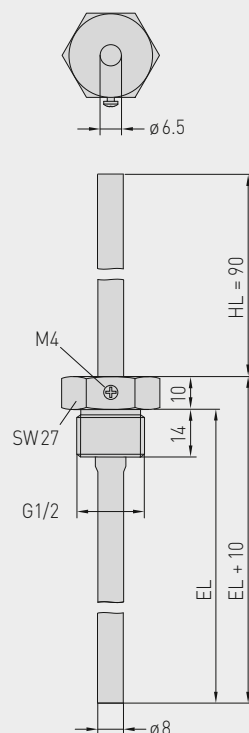

**Dimensional drawing  
MF-06-M**

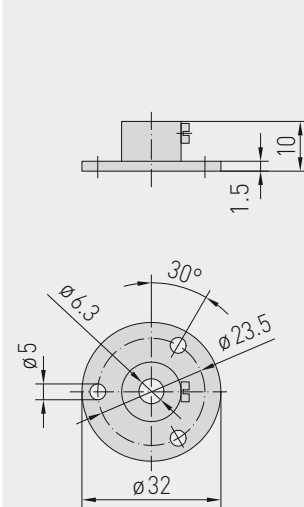



...through combination with accessories:



**TH - ms / xx**  
Immersion sleeve,  
brass, nickel-plated,  
thread-sealing, conical,  
according to DIN 10226



**TH - VA / xx**  
Immersion sleeve,  
stainless steel, V4A,  
flat-sealing, cylindrical,  
according to DIN 228



**TH - VA / xx / 90**  
Immersion sleeve with neck tube,  
stainless steel, V4A,  
flat-sealing, cylindrical,  
according to DIN 228



**MF-06-M**  
Mounting flange,  
metal

THERMASGARD® TH Immersion sleeve Ø 8 mm (accessories)					
Type / WG01	p <sub>max</sub> (static)	T <sub>max</sub>	Inserted Length (EL)	Item No.	Price
<b>TH - ms / xx</b> Brass nickel-plated					
TH-MS 50MM	10 bar	+150 °C	50 mm	7100-0011-0010-001	8,87 €
TH-MS 100MM	10 bar	+150 °C	100 mm	7100-0011-0020-001	10,10 €
TH-MS 150MM	10 bar	+150 °C	150 mm	7100-0011-0030-001	10,67 €
TH-MS 200MM	10 bar	+150 °C	200 mm	7100-0011-0040-001	11,01 €
TH-MS 250MM	10 bar	+150 °C	250 mm	7100-0011-0050-001	12,75 €
TH-MS 300MM	10 bar	+150 °C	300 mm	7100-0011-0060-001	13,10 €
TH-MS 350MM	10 bar	+150 °C	350 mm	7100-0011-0070-001	13,21 €
TH-MS 400MM	10 bar	+150 °C	400 mm	7100-0011-0080-001	13,33 €
<b>TH - VA / xx</b> Stainless steel, V4A (1.4571)					
without neck tube					
TH-VA 50MM	40 bar	+600 °C	50 mm	7100-0012-0010-001	19,31 €
TH-VA 100MM	40 bar	+600 °C	100 mm	7100-0012-0020-001	21,34 €
TH-VA 150MM	40 bar	+600 °C	150 mm	7100-0012-0030-001	22,93 €
TH-VA 200MM	40 bar	+600 °C	200 mm	7100-0012-0040-001	24,17 €
TH-VA 250MM	40 bar	+600 °C	250 mm	7100-0012-0050-001	30,05 €
TH-VA 300MM	40 bar	+600 °C	300 mm	7100-0012-0060-001	31,40 €
TH-VA 350MM	40 bar	+600 °C	350 mm	7100-0012-0070-001	31,61 €
TH-VA 400MM	40 bar	+600 °C	400 mm	7100-0012-0080-001	32,17 €
<b>TH - VA / xx / 90</b> Stainless steel, V4A (1.4571)					
with neck tube (90 mm)					
TH-VA 50/90MM	40 bar	+600 °C	50 mm	7100-0012-2010-001	27,66 €
TH-VA 100/90MM	40 bar	+600 °C	100 mm	7100-0012-2020-001	28,90 €
TH-VA 150/90MM	40 bar	+600 °C	150 mm	7100-0012-2030-001	30,32 €
TH-VA 200/90MM	40 bar	+600 °C	200 mm	7100-0012-2040-001	31,61 €
TH-VA 250/90MM	40 bar	+600 °C	250 mm	7100-0012-2050-001	33,13 €
TH-VA 300/90MM	40 bar	+600 °C	300 mm	7100-0012-2060-001	35,91 €
Note:	inner diameter of socket 6.5 mm For further information see last chapter!				
<b>Mounting flange (accessories)</b>					
Type / WG01		T <sub>max</sub>		Item No.	Price
<b>MF</b>					
<b>MF-06-M</b>	Mounting flange, metal (galvanised steel) Ø 32 mm, tube gland Ø 6.3 mm		+700 °C	7100-0030-5000-100	9,10 €
Note:	For further information see last chapter!				

**Screw-in/immersion temperature sensor with neck tube,  
with passive output**
**ETF 6**  
standard

Screw-in resistance thermometer / temperature sensor with neck tube  
**THERMASGARD® ETF 6** with passive output, with connecting head made from aluminium (optionally with **cable gland** or **M12 connector** according to DIN EN 61076-2-101) and straight protective tube.

The duct sensor is used to detect temperatures in liquid or gaseous media. It is used in pipes, tanks or storage systems, preferably where tubes or tanks must be isolated.

**TECHNICAL DATA**

Measuring range:	-35...+180 °C ( $T_{\max}$ NTC = +150 °C, $T_{\max}$ LM235Z = +125 °C)
Sensors / output:	see table, passive <b>(Perfect Sensor Protection)</b> (optionally also with two or other sensors)
Connection type:	2-wire connection (4-wire connection on PT100, optional on other sensors)
Testing current:	< 0.6 mA (Pt1000) < 1.0 mA (Pt100) < 0.3 mA (Ni1000, Ni1000 TK5000) < 2.0 mW (NTC xx) 400 µA...5 mA (LM235Z)
Insulating resistance:	≥ 100 MΩ, at +20 °C (500 V DC)
Electrical connection:	0.14 - 2.5 mm <sup>2</sup> , via terminal screws on ceramic base
Cable connection:	<b>ETF 6</b> (standard) adjusting screw made of metal (M20 x 1,5) <b>ETF 6-KV</b> (optional) cable gland, brass, nickel-plated (M20 x 1.5; with strain relief, exchangeable, inner diameter 6 - 12 mm) <b>ETF 6-Q</b> (optional) M12 connector according to DIN EN 61076-2-101 (male, 5-pin, A-code)
Dimensions:	see dimensional drawing
Connecting head:	form B, material aluminium, colour white aluminium (similar RAL 9006), ambient temperature -20...+100 °C
Protective tube:	stainless steel <b>V4A</b> (1.4571), G ½" straight pipe thread, wrench size 27 mm, $p_{\max}$ = 40 bar, Ø = 8 mm length of neck tube (HL) = 80 mm inserted length (EL) = 100 - 400 mm (see table)
Process connection:	screwed socket with G ½"
Humidity:	< 95 % r. H., non-precipitating air
Protection class:	III (according to EN 60 730)
Protection type:	<b>IP 54</b> (according to EN 60 529) <b>ETF 6</b> <b>IP 65</b> (according to EN 60 529) <b>ETF 6-KV / ETF 6-Q</b>

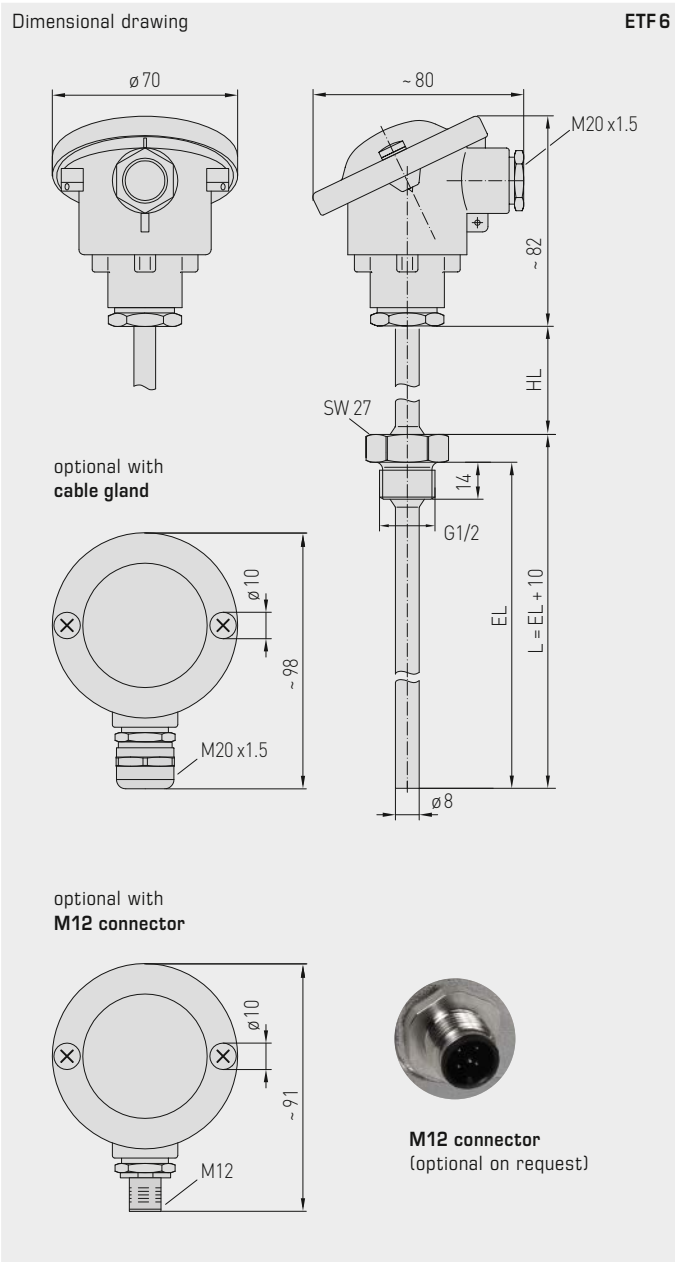

High-performance encapsulation against vibration, mechanical stress and humidity



ETF 6 standard (IP 54)



ETF 6-KV with cable gland (IP 65)



ETF 6-Q with M12 connector (IP 65)





Screw-in/immersion temperature sensor with neck tube,  
with passive output

S+S REGELTECHNIK



ETF6  
standard  
(IP 54)

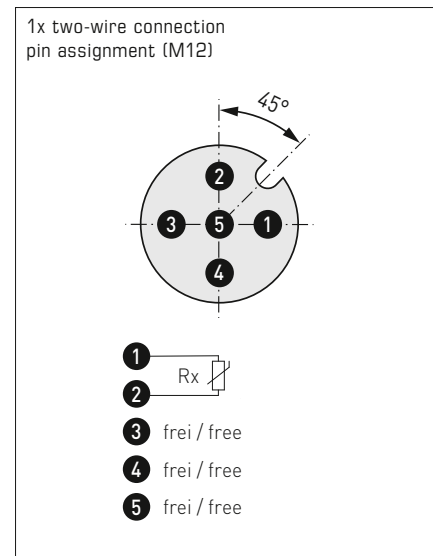
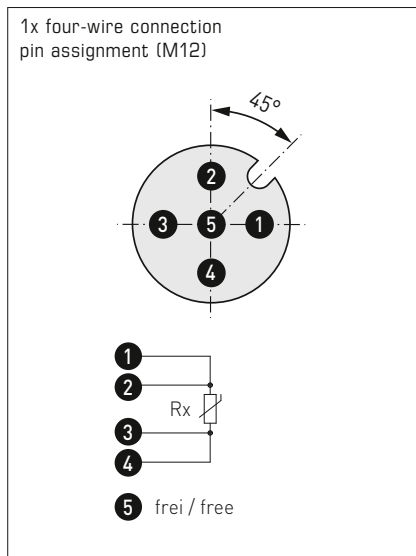
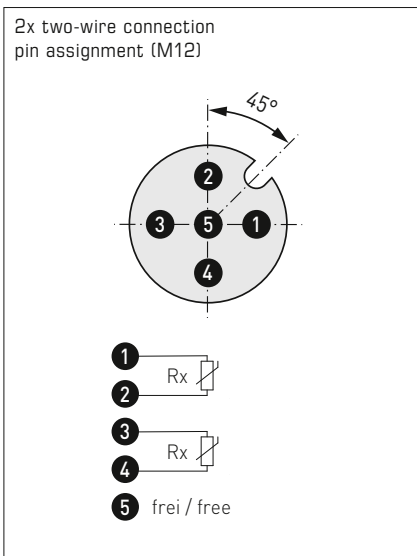
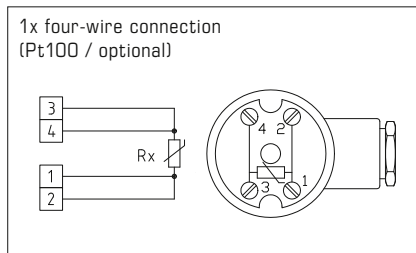
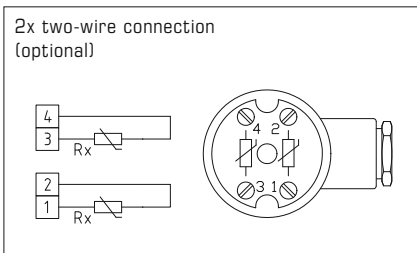
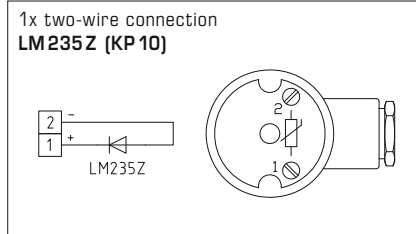
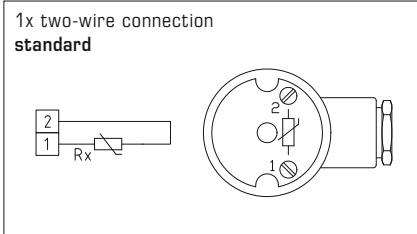

THERMASGARD® ETF 6		Screw-in / immersion temperature sensor with neck tube (standard)			
Type/WG03	Sensor/Output	Installation length (EL)	Item No.	Price	
<b>ETF6 Pt100 xx</b>	<b>Pt100</b> (according to DIN EN 60751, class B)		<b>IP 54, 4-wire</b>		
ETF6 Pt100 100/80	Pt100	100 mm	1101-2070-1023-000	80,64 €	
ETF6 Pt100 150/80	Pt100	150 mm	1101-2070-1033-000	84,88 €	
ETF6 Pt100 200/80	Pt100	200 mm	1101-2070-1043-000	87,29 €	
ETF6 Pt100 250/80	Pt100	250 mm	1101-2070-1053-000	89,60 €	
ETF6 Pt100 400/80	Pt100	400 mm	1101-2070-1083-000	92,40 €	
<b>ETF6 Pt1000 xx</b>	<b>Pt1000</b> (according to DIN EN 60751, class B)		<b>IP 54, 2-wire</b>		
ETF6 Pt1000 100/80	Pt1000	100 mm	1101-2070-5021-000	82,57 €	
ETF6 Pt1000 150/80	Pt1000	150 mm	1101-2070-5031-000	87,29 €	
ETF6 Pt1000 200/80	Pt1000	200 mm	1101-2070-5041-000	88,68 €	
ETF6 Pt1000 250/80	Pt1000	250 mm	1101-2070-5051-000	89,73 €	
ETF6 Pt1000 400/80	Pt1000	400 mm	1101-2070-5081-000	93,29 €	

Continued on next page...



THERMASGARD® ETF 6		Screw-in / immersion temperature sensor with neck tube (standard)		
Type / WG03	Sensor / Output	Installation length (EL)	Item No.	Price
<b>ETF6 Ni1000 xx</b>	<b>Ni1000</b> (according to DIN EN 43760, class B, TCR = 6180 ppm/K)		<b>IP54, 2-wire</b>	
ETF6 Ni1000 100/80	Ni1000	100 mm	1101-2070-9021-000	85,70 €
ETF6 Ni1000 150/80	Ni1000	150 mm	1101-2070-9031-000	87,22 €
ETF6 Ni1000 200/80	Ni1000	200 mm	1101-2070-9041-000	89,58 €
ETF6 Ni1000 250/80	Ni1000	250 mm	1101-2070-9051-000	90,04 €
ETF6 Ni1000 400/80	Ni1000	400 mm	1101-2070-9081-000	94,58 €
<b>ETF6 Ni1000TK xx</b>	<b>Ni1000 TK5000</b> (TCR = 5000 ppm/K), LG-Ni1000		<b>IP54, 2-wire</b>	
ETF6 NiTK 100/80	Ni1000 TK5000	100 mm	1101-2071-0021-000	86,09 €
ETF6 NiTK 150/80	Ni1000 TK5000	150 mm	1101-2071-0031-000	88,11 €
ETF6 NiTK 200/80	Ni1000 TK5000	200 mm	1101-2071-0041-000	90,40 €
ETF6 NiTK 250/80	Ni1000 TK5000	250 mm	1101-2071-0051-000	93,17 €
ETF6 NiTK 400/80	Ni1000 TK5000	400 mm	1101-2071-0081-000	95,54 €
<b>ETF6 LM235Z xx</b>	<b>LM235Z</b> (TCR = 10mV/K; 2.73V at 0°C), KP10		<b>IP54, 2-wire</b>	
ETF6 LM235Z 100/80	LM235Z	100 mm	1101-2072-1021-000	81,85 €
ETF6 LM235Z 150/80	LM235Z	150 mm	1101-2072-1031-000	85,47 €
ETF6 LM235Z 200/80	LM235Z	200 mm	1101-2072-1041-000	87,29 €
ETF6 LM235Z 250/80	LM235Z	250 mm	1101-2072-1051-000	88,51 €
ETF6 LM235Z 400/80	LM235Z	400 mm	1101-2072-1081-000	94,09 €
<b>ETF6 NTC 1,8K xx</b>	<b>NTC 1,8K</b>		<b>IP54, 2-wire</b>	
ETF6 NTC1,8K 100/80	NTC 1,8K	100 mm	1101-2071-2021-000	85,84 €
ETF6 NTC1,8K 150/80	NTC 1,8K	150 mm	1101-2071-2031-000	87,12 €
ETF6 NTC1,8K 200/80	NTC 1,8K	200 mm	1101-2071-2041-000	88,45 €
ETF6 NTC1,8K 250/80	NTC 1,8K	250 mm	1101-2071-2051-000	92,26 €
ETF6 NTC1,8K 400/80	NTC 1,8K	400 mm	1101-2071-2081-000	94,87 €
<b>ETF6 NTC10K xx</b>	<b>NTC 10K</b>		<b>IP54, 2-wire</b>	
ETF6 NTC10K 100/80	NTC 10K	100 mm	1101-2071-5021-000	85,84 €
ETF6 NTC10K 150/80	NTC 10K	150 mm	1101-2071-5031-000	87,12 €
ETF6 NTC10K 200/80	NTC 10K	200 mm	1101-2071-5041-000	88,45 €
ETF6 NTC10K 250/80	NTC 10K	250 mm	1101-2071-5051-000	92,26 €
ETF6 NTC10K 400/80	NTC 10K	400 mm	1101-2071-5081-000	94,87 €
<b>ETF6 NTC20K xx</b>	<b>NTC 20K</b>		<b>IP54, 2-wire</b>	
ETF6 NTC20K 100/80	NTC 20K	100 mm	1101-2071-6021-000	85,84 €
ETF6 NTC20K 150/80	NTC 20K	150 mm	1101-2071-6031-000	87,12 €
ETF6 NTC20K 200/80	NTC 20K	200 mm	1101-2071-6041-000	88,45 €
ETF6 NTC20K 250/80	NTC 20K	250 mm	1101-2071-6051-000	92,26 €
ETF6 NTC20K 400/80	NTC 20K	400 mm	1101-2071-6081-000	94,87 €
<b>Housing variant:</b>	equipped as standard with pressure screw ( <b>IP54</b> ), optional housing variants with cable gland ( <b>IP65</b> ) or <b>M12 connector (IP65)</b> see the next page!			
Extra charge:	optionally also with two or other sensors			on request

Screw-in / immersion temperature sensor with neck tube,  
with passive output

S+S REGELTECHNIK

ETF6-Q  
with M12 connector  
(IP65)



THERMASGARD® ETF 6-Q		Screw-in / immersion temperature sensor with neck tube (with M12 connector)			
Type / WG03	Sensor / Output	Installation length (EL)	Q	Item No.	Price
<b>ETF6 Pt100 xx Q</b>		<b>Pt100</b> (according to DIN EN 60751, class B)		<b>IP65, 4-wire</b>	
ETF6 Pt100 100/80mm Q	Pt100	100 mm	●	2Z01-4121-0100-041	120,57 €
ETF6 Pt100 150/80mm Q	Pt100	150 mm	●	2Z01-4121-0100-051	124,80 €
ETF6 Pt100 200/80mm Q	Pt100	200 mm	●	2Z01-4121-0100-061	127,22 €
ETF6 Pt100 250/80mm Q	Pt100	250 mm	●	2Z01-4121-0100-071	129,52 €
ETF6 Pt100 400/80mm Q	Pt100	400 mm	●	2Z01-4121-0100-101	132,42 €
<b>ETF6 Pt1000 xx Q</b>		<b>Pt1000</b> (according to DIN EN 60751, class B)		<b>IP65, 2-wire</b>	
ETF6 Pt1000 100/80mm Q	Pt1000	100 mm	●	2Z05-4121-0100-041	120,57 €
ETF6 Pt1000 150/80mm Q	Pt1000	150 mm	●	2Z05-4121-0100-051	124,80 €
ETF6 Pt1000 200/80mm Q	Pt1000	200 mm	●	2Z05-4121-0100-061	127,22 €
ETF6 Pt1000 250/80mm Q	Pt1000	250 mm	●	2Z05-4121-0100-071	129,52 €
ETF6 Pt1000 400/80mm Q	Pt1000	400 mm	●	2Z05-4121-0100-101	132,32 €
<b>Housing variant "Q":</b>	Cable connection with M12 connector (male, 5-pin, A-code)				
Extra charge:	optionally also with two or other sensors				on request

**ACCESSORIES**

Special accessories for M12 connector  
see chapter Accessories!



Screw-in / immersion temperature sensor with neck tube,  
with passive output

ETF6 - KV  
with cable gland  
(IP65)



THERMASGARD® ETF 6 - KV		Screw-in / immersion temperature sensor with neck tube (with cable gland)		
Type / WG03	Sensor / Output	Installation length (EL)	Item No.	Price
<b>ETF6 Pt100 xx KV</b>	<b>Pt100</b> (according to DIN EN 60751, class B)		<b>IP65, 4-wire</b>	
ETF6 Pt100 100/80mm KV	Pt100	100 mm	1101-20C0-1023-000	89,63 €
ETF6 Pt100 150/80mm KV	Pt100	150 mm	1101-20C0-1033-000	93,86 €
ETF6 Pt100 200/80mm KV	Pt100	200 mm	1101-20C0-1043-000	96,28 €
ETF6 Pt100 250/80mm KV	Pt100	250 mm	1101-20C0-1053-000	98,58 €
ETF6 Pt100 400/80mm KV	Pt100	400 mm	1101-20C0-1083-000	101,38 €
<b>ETF6 Pt1000 xx KV</b>	<b>Pt1000</b> (according to DIN EN 60751, class B)		<b>IP65, 2-wire</b>	
ETF6 Pt1000 100/80mm KV	Pt1000	100 mm	1101-20C0-5021-000	91,55 €
ETF6 Pt1000 150/80mm KV	Pt1000	150 mm	1101-20C0-5031-000	96,28 €
ETF6 Pt1000 200/80mm KV	Pt1000	200 mm	1101-20C0-5041-000	97,66 €
ETF6 Pt1000 250/80mm KV	Pt1000	250 mm	1101-20C0-5051-000	98,71 €
ETF6 Pt1000 400/80mm KV	Pt1000	400 mm	1101-20C0-5081-000	102,28 €
<b>Housing variant "KV":</b>	Cable connection <b>with cable gland</b>			
Extra charge:	optionally also with two or other sensors		on request	

**Duct temperature sensors / smoke gas temperature sensors, including mounting flange, with passive output**

**RGTF 1**  
standard

Resistance thermometer / smoke gas temperature sensor **THERMASGARD® RGTF 1** with passive output, with connecting head made from aluminium (optionally with **cable gland** or **M12 connector** according to DIN EN 61076-2-101) and straight protective tube, incl. mounting flange.

The duct sensor is used to detect relatively high temperatures in gaseous media, eg, for exhaust air and smoke gas temperature measurement.

**TECHNICAL DATA**

Measuring range:	-35...+600 °C (extended range limits from -100...+750 °C optional)
Sensor / output:	Pt100/Pt1000 (according to DIN EN 60 751, class B) <b>(Perfect Sensor Protection)</b>
Connection type:	2-wire connection (Pt1000) 4-wire connection (Pt100 / Pt1000 optional)
Testing current:	< 0.6 mA (Pt1000) < 1.0 mA (Pt100)
Insulating resistance:	≥ 100 MΩ, at +20 °C (500 V DC)
Electrical connection:	0.14 - 2.5 mm <sup>2</sup> via terminal screws on ceramic base
Cable connection:	<b>RGTF 1</b> (standard) adjusting screw made of metal (M20 x 1.5); <b>RGTF 1-KV</b> (optional) cable gland, brass, nickel-plated (M20 x 1.5; with strain relief, exchangeable, inner diameter 6 - 12 mm) <b>RGTF 1-Q</b> (optional) M12 connector according to DIN EN 61076-2-101 (male, 5-pin, A-code)
Dimensions:	see dimensional drawing
Connecting head:	form B, material aluminium, colour white aluminium (similar to RAL 9006), ambient temperature -20...+100 °C
Protective tube:	stainless steel <b>V4A</b> (1.4571), Ø = 8 mm inserted length (EL) = 200 - 500 mm (see table)
Process connection:	by mounting flange, stainless steel <b>V2A</b> (1.4305) (included in the scope of delivery)
Humidity:	< 95 % r. H., non-precipitating air
Protection class:	III (according to EN 60 730)
Protection type:	<b>IP 54</b> (according to EN 60 529) <b>RGTF 1</b> <b>IP 65</b> (according to EN 60 529) <b>RGTF1-KV / RGTF1-Q</b>



**RGTF 1**  
Measuring insert with  
ceramic tubelet



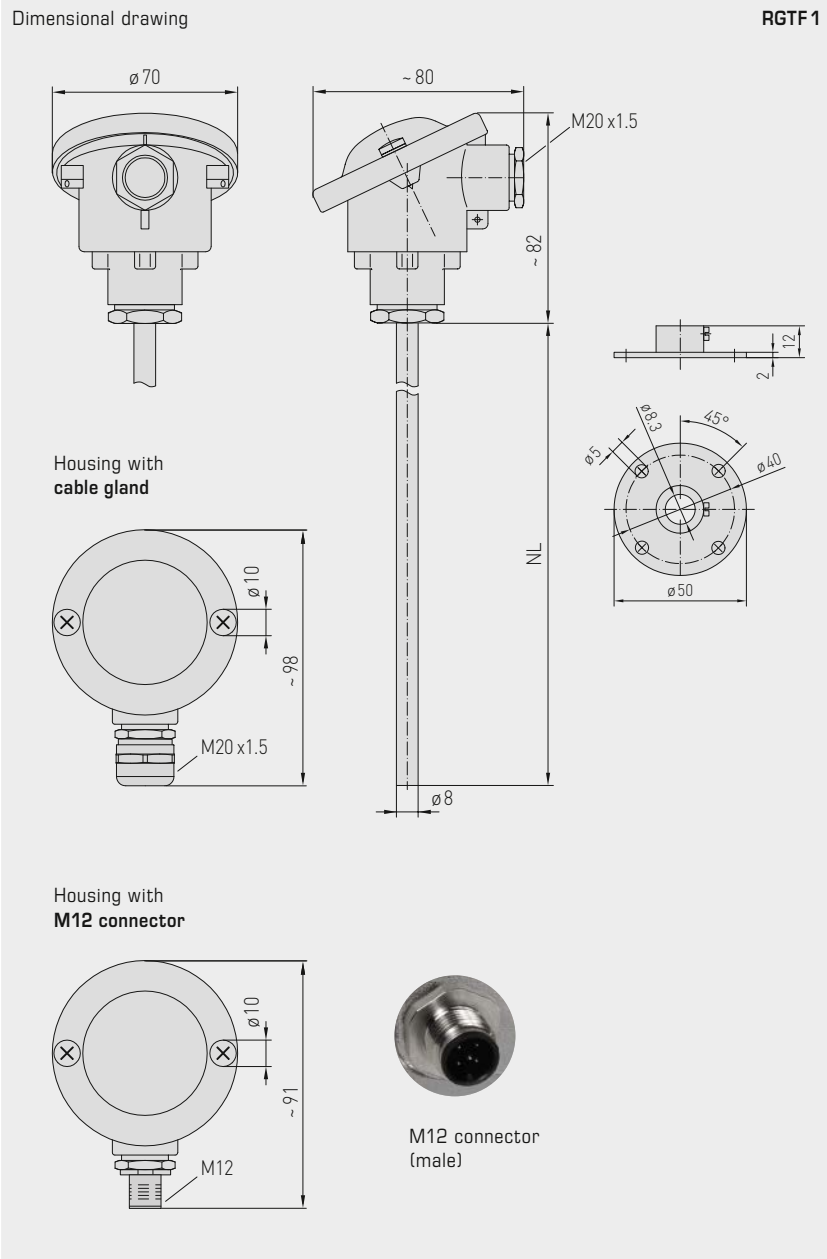

RGTF 1 standard (IP54)



RGTF 1-KV with cable gland (IP65)



RGTF 1-Q with M12 connector (IP65)



High-performance encapsulation against vibration, mechanical stress and humidity

**PS-PROTECTION**  
PERFECT SENSOR PROTECTION



Duct temperature sensors / smoke gas temperature sensors,  
including mounting flange, with passive output

2-wire connection  
(Pt1000)



4-wire connection  
(Pt100 / Pt1000 optional)



1x two-wire connection  
(Pt1000)

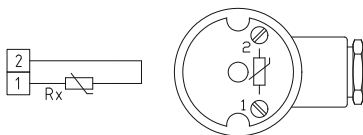

1x four-wire connection  
(Pt100 / Pt1000 optional)

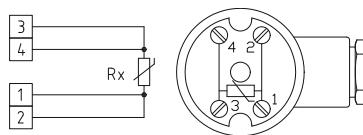

1x two-wire connection  
pin assignment (M12)

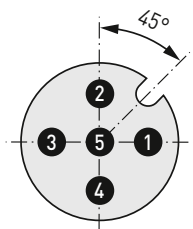

- 1 Rx
- 2
- 3 frei / free
- 4 frei / free
- 5 frei / free

1x four-wire connection  
pin assignment (M12)

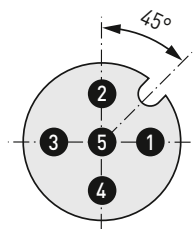

- 1
- 2 Rx
- 3
- 4
- 5 frei / free



RGTF 1  
standard  
(IP54)



THERMASGARD® RGTF 1		Duct temperature sensors / smoke gas temperature sensors, including mounting flange (Standard)		
Type / WG01	Sensor / Output	Installation length (EL)	Item No.	Price
<b>RGTF1 Pt100 xx</b>	<b>Pt100</b> (according to DIN EN 60751, class B)		<b>IP54, 4-wire</b>	
RGTF1 Pt100 200mm	Pt100	200 mm	1101-3040-1043-000	175,68 €
RGTF1 Pt100 250mm	Pt100	250 mm	1101-3040-1053-000	177,51 €
RGTF1 Pt100 300mm	Pt100	300 mm	1101-3040-1063-000	181,50 €
RGTF1 Pt100 500mm	Pt100	500 mm	1101-3040-1103-000	195,58 €
<b>RGTF1 Pt1000 xx</b>	<b>Pt1000</b> (according to DIN EN 60751, class B)		<b>IP54, 2-wire</b>	
RGTF1 Pt1000 200mm	Pt1000	200 mm	1101-3040-5041-000	169,73 €
RGTF1 Pt1000 250mm	Pt1000	250 mm	1101-3040-5051-000	171,56 €
RGTF1 Pt1000 300mm	Pt1000	300 mm	1101-3040-5061-000	175,55 €
RGTF1 Pt1000 500mm	Pt1000	500 mm	1101-3040-5101-000	180,76 €
<b>Housing variant:</b>	equipped as standard with pressure screw (IP54), optional housing variants with cable gland (IP65) or M12 connector (IP65) see the next page!			
Extra charge:	other measuring ranges optional			on request

Duct temperature sensors / smoke gas temperature sensors,  
including mounting flange, with passive output

S+S REGELTECHNIK

**RGTF 1 - Q**  
with M12 connector  
(IP 65)



THERMASGARD® RGTF 1 - Q		Duct temperature sensors / smoke gas temperature sensors, including mounting flange (with M12 connector)			
Type / WG03	Sensor / Output	Installation length (EL)	Q	Item No.	Price
<b>RGTF1 Pt100 xx Q</b>	<b>Pt100</b> (according to DIN EN 60751, class B)		●	<b>IP 65, 4-wire</b>	
RGTF1 Pt100 200mm Q	Pt100	200 mm	●	2Z01-4131-0100-011	209,56 €
RGTF1 Pt100 250mm Q	Pt100	250 mm	●	2Z01-4131-0100-021	211,49 €
RGTF1 Pt100 300mm Q	Pt100	300 mm	●	2Z01-4131-0100-031	215,47 €
RGTF1 Pt100 500mm Q	Pt100	500 mm	●	2Z01-4131-0100-041	220,70 €
<b>RGTF1 Pt1000 xx Q</b>	<b>Pt1000</b> (according to DIN EN 60751, class B)		●	<b>IP 65, 2-wire</b>	
RGTF1 Pt1000 200mm Q	Pt1000	200 mm	●	2Z05-4131-0100-011	209,56 €
RGTF1 Pt1000 250mm Q	Pt1000	250 mm	●	2Z05-4131-0100-021	211,49 €
RGTF1 Pt1000 300mm Q	Pt1000	300 mm	●	2Z05-4131-0100-031	215,47 €
RGTF1 Pt1000 500mm Q	Pt1000	500 mm	●	2Z05-4131-0100-041	220,70 €
<b>Housing variant "Q":</b>	Cable connection <b>with M12 connector</b> (male, <b>5-pin</b> , A-code)				
Extra charge:	other measuring ranges optional			on request	

**ACCESSORIES**

Special accessories for M12 connector  
see chapter Accessories!



Duct temperature sensors / smoke gas temperature sensors,  
including mounting flange, with passive output

RGTF 1 - KV  
with cable gland  
(IP 65)



**THERMASGARD®** Duct temperature sensors / smoke gas temperature sensors, including mounting flange  
**RGTF 1 - KV** (with cable gland)

Type / WG01	Sensor / Output	Installation length (EL)	Item No.	Price
<b>RGTF1 Pt100 xx KV</b>	<b>Pt100</b> (according to DIN EN 60751, class B)		<b>IP65, 4-wire</b>	
RGTF1 Pt100 200mm KV	Pt100	200 mm	1101-30D0-1043-000	178,72 €
RGTF1 Pt100 250mm KV	Pt100	250 mm	1101-30D0-1053-000	180,55 €
RGTF1 Pt100 300mm KV	Pt100	300 mm	1101-30D0-1063-000	184,54 €
RGTF1 Pt100 500mm KV	Pt100	500 mm	1101-30D0-1103-000	189,76 €
<b>RGTF1 Pt1000 xx KV</b>	<b>Pt1000</b> (according to DIN EN 60751, class B)		<b>IP65, 2-wire</b>	
RGTF1 Pt1000 200mm KV	Pt1000	200 mm	1101-30D0-5041-000	178,72 €
RGTF1 Pt1000 250mm KV	Pt1000	250 mm	1101-30D0-5051-000	180,55 €
RGTF1 Pt1000 300mm KV	Pt1000	300 mm	1101-30D0-5061-000	184,54 €
RGTF1 Pt1000 500mm KV	Pt1000	500 mm	1101-30D0-5101-000	189,76 €
<b>Housing variant "KV":</b>	<b>Cable connection with cable gland</b>			
Extra charge:	other measuring ranges optional			on request



**Screw-in temperature sensors / smoke gas temperature sensors with neck tube and passive output**

**RGTF 2**  
standard

Screw-in resistance thermometer / smoke gas temperature sensor with neck tube **THERMASGARD® RGTF 2** with passive output, with connecting head made from aluminium (optionally with **cable gland** or **M12 connector** according to DIN EN 61076-2-101) and straight protective tube.

The duct sensor is used to detect relatively high temperatures in liquid or gaseous media, eg, for exhaust air and smoke gas temperature measurement..

**TECHNICAL DATA**

Measuring range:	-35...+600 °C (extended range limits from -100...+750 °C optional)
Sensor / output:	Pt100/Pt1000 (according to DIN EN 60 751, class B) <b>(Perfect Sensor Protection)</b>
Connection type:	2-wire connection (Pt1000) 4-wire connection (Pt100 / Pt1000 optional)
Testing current:	< 0.6 mA (Pt1000) < 1.0 mA (Pt100)
Insulating resistance:	≥ 100 MΩ, at +20 °C (500 V DC)
Electrical connection:	0.14 - 2.5 mm <sup>2</sup> via terminal screws on ceramic base
Cable connection:	<b>RGTF 2</b> (Standard) adjusting screw made of metal (M20 x 1.5); <b>RGTF 2-KV</b> (optional) <b>cable gland</b> , brass, nickel-plated (M20 x 1.5; with strain relief, exchangeable, inner diameter 6 - 12 mm) <b>RGTF 2-Q</b> (optional) M12 connector according to DIN EN 61076-2-101 (male, 5-pin, A-code)
Dimensions:	see dimensional drawing
Connecting head:	form B, material aluminium, colour white aluminium (similar to RAL 9006), ambient temperature -20...+100 °C
Protective tube:	stainless steel <b>V4A</b> (1.4571), G ½" straight pipe thread, wrench size 27 mm, p <sub>max</sub> = 40 bar, Ø = 8 mm length of neck tube (HL) = 80 mm inserted length (EL) = 100 - 500 mm (see table)
Process connection:	screwed socket with G ½" straight pipe thread
Humidity:	< 95 % r. H., non-precipitating air
Protection class:	III (according to EN 60 730)
Protection type:	<b>IP 54</b> (according to EN 60 529) <b>RGTF 2</b> <b>IP 65</b> (according to EN 60 529) <b>RGTF 2-KV / RGTF 2-Q</b>



**RGTF 2**  
Measuring insert with ceramic tubelet

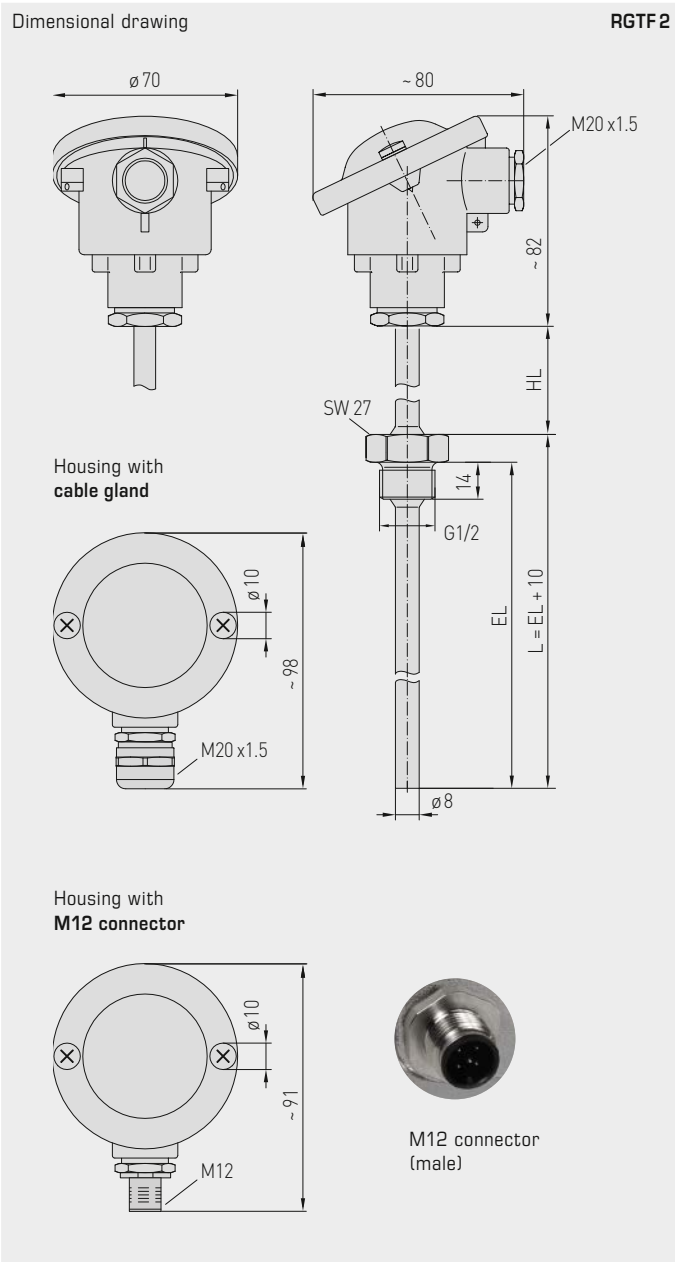

High-performance encapsulation against vibration, mechanical stress and humidity

**PS-PROTECTION**  
PERFECT SENSOR PROTECTION



Screw-in temperature sensors / smoke gas temperature sensors  
with neck tube and passive output

2-wire connection  
(Pt1000)

4-wire connection  
(Pt100 / Pt1000 optional)



1x two-wire connection  
(Pt1000)

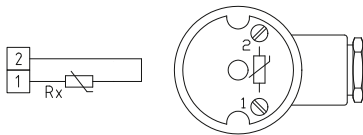

1x four-wire connection  
(Pt100 / Pt1000 optional)

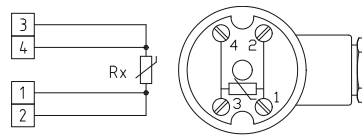

1x two-wire connection  
pin assignment (M12)

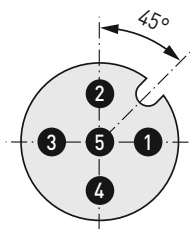

- 1 Rx
- 2 Rx
- 3 frei / free
- 4 frei / free
- 5 frei / free

1x four-wire connection  
pin assignment (M12)

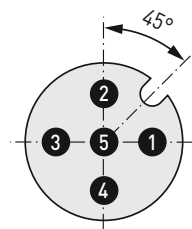

- 1 Rx
- 2 Rx
- 3 Rx
- 4 Rx
- 5 frei / free



RGTF2  
standard  
(IP54)



THERMASGARD® RGTF 2		Screw-in temperature sensors / smoke gas temperature sensors with neck tube (standard)		
Type / WG01	Sensor / Output	Installation length (EL)	Item No.	Price
<b>RGTF2 Pt100 xx</b>	<b>Pt100</b> (according to DIN EN 60751, class B)		<b>IP54, 4-wire</b>	
RGTF2 Pt100 100/80mm	Pt100	100 mm	1101-2090-1023-000	195,09 €
RGTF2 Pt100 150/80mm	Pt100	150 mm	1101-2090-1033-000	196,17 €
RGTF2 Pt100 200/80mm	Pt100	200 mm	1101-2090-1043-000	202,23 €
RGTF2 Pt100 250/80mm	Pt100	250 mm	1101-2090-1053-000	197,62 €
RGTF2 Pt100 300/80mm	Pt100	300 mm	1101-2090-1063-000	211,93 €
RGTF2 Pt100 500/80mm	Pt100	500 mm	1101-2090-1103-000	225,28 €
<b>RGTF2 Pt1000 xx</b>	<b>Pt1000</b> (according to DIN EN 60751, class B)		<b>IP54, 2-wire</b>	
RGTF2 Pt1000 100/80	Pt1000	100 mm	1101-2090-5021-000	189,13 €
RGTF2 Pt1000 150/80	Pt1000	150 mm	1101-2090-5031-000	190,35 €
RGTF2 Pt1000 200/80	Pt1000	200 mm	1101-2090-5041-000	196,42 €
RGTF2 Pt1000 250/80	Pt1000	250 mm	1101-2090-5051-000	197,63 €
RGTF2 Pt1000 300/80	Pt1000	300 mm	1101-2090-5061-000	206,10 €
RGTF2 Pt1000 500/80	Pt1000	500 mm	1101-2090-5101-000	219,45 €
<b>Housing variant:</b>	equipped as standard with pressure screw (IP54), optional housing variants with cable gland (IP65) or M12 connector (IP65) see the next page!			
Extra charge:	other measuring ranges optional			on request

**RGTF2 - Q**  
with M12 connector  
(IP65)



THERMASGARD® RGTF 2 - Q		Screw-in temperature sensors / smoke gas temperature sensors with neck tube (with M12 connector)			
Type / WG03	Sensor / Output	Installation length (EL)	Q	Item No.	Price
<b>RGTF2 Pt100 xx Q</b>	<b>Pt100</b> (according to DIN EN 60751, class B)		●	<b>IP 65, 4-wire</b>	
RGTF2 Pt100 100/80mm Q	Pt100	100 mm	●	2Z01-4141-0100-011	229,06 €
RGTF2 Pt100 150/80mm Q	Pt100	150 mm	●	2Z01-4141-0100-021	230,28 €
RGTF2 Pt100 200/80mm Q	Pt100	200 mm	●	2Z01-4141-0100-031	236,34 €
RGTF2 Pt100 250/80mm Q	Pt100	250 mm	●	2Z01-4141-0100-041	237,55 €
RGTF2 Pt100 300/80mm Q	Pt100	300 mm	●	2Z01-4141-0100-051	246,03 €
RGTF2 Pt100 500/80mm Q	Pt100	500 mm	●	2Z01-4141-0100-061	259,37 €
<b>RGTF2 Pt1000 xx Q</b>	<b>Pt1000</b> (according to DIN EN 60751, class B)		●	<b>IP 65, 2-wire</b>	
RGTF2 Pt1000 100/80mm Q	Pt1000	100 mm	●	2Z05-4141-0100-011	229,06 €
RGTF2 Pt1000 150/80mm Q	Pt1000	150 mm	●	2Z05-4141-0100-021	230,28 €
RGTF2 Pt1000 200/80mm Q	Pt1000	200 mm	●	2Z05-4141-0100-031	236,34 €
RGTF2 Pt1000 250/80mm Q	Pt1000	250 mm	●	2Z05-4141-0100-041	237,55 €
RGTF2 Pt1000 300/80mm Q	Pt1000	300 mm	●	2Z05-4141-0100-051	246,03 €
RGTF2 Pt1000 500/80mm Q	Pt1000	500 mm	●	2Z05-4141-0100-061	259,37 €
<b>Housing variant "Q":</b>	Cable connection with M12 connector (male, 5-pin, A-code)				
Extra charge:	other measuring ranges optional				on request

**ACCESSORIES**

Special accessories for M12 connector  
see chapter Accessories!





RGTF2 - KV  
with cable gland  
(IP65)



THERMASGARD® RGTF 2 - KV		Screw-in temperature sensors / smoke gas temperature sensors with neck tube (with cable gland)		
Type / WG01	Sensor / Output	Installation length (EL)	Item No.	Price
<b>RGTF2 Pt100 xx KV</b>	<b>Pt100</b> (according to DIN EN 60751, class B)		<b>IP65, 4-wire</b>	
RGTF2 Pt100 100/80mm KV	Pt100	100 mm	1101-20D0-1023-000	198,13 €
RGTF2 Pt100 150/80mm KV	Pt100	150 mm	1101-20D0-1033-000	199,34 €
RGTF2 Pt100 200/80mm KV	Pt100	200 mm	1101-20D0-1043-000	205,41 €
RGTF2 Pt100 250/80mm KV	Pt100	250 mm	1101-20D0-1053-000	206,60 €
RGTF2 Pt100 300/80mm KV	Pt100	300 mm	1101-20D0-1063-000	215,09 €
RGTF2 Pt100 500/80mm KV	Pt100	500 mm	1101-20D0-1103-000	228,44 €
<b>RGTF2 Pt1000 xx KV</b>	<b>Pt1000</b> (according to DIN EN 60751, class B)		<b>IP65, 2-wire</b>	
RGTF2 Pt1000 100/80mm KV	Pt1000	100 mm	1101-20D0-5021-000	198,13 €
RGTF2 Pt1000 150/80mm KV	Pt1000	150 mm	1101-20D0-5031-000	199,34 €
RGTF2 Pt1000 200/80mm KV	Pt1000	200 mm	1101-20D0-5041-000	205,41 €
RGTF2 Pt1000 250/80mm KV	Pt1000	250 mm	1101-20D0-5051-000	206,60 €
RGTF2 Pt1000 300/80mm KV	Pt1000	300 mm	1101-20D0-5061-000	215,09 €
RGTF2 Pt1000 500/80mm KV	Pt1000	500 mm	1101-20D0-5101-000	228,44 €
<b>Housing variant "KV":</b>		Cable connection <b>with cable gland</b>		
Extra charge:	other measuring ranges optional			on request

**Sleeve sensor / cable temperature sensor**  
**duct / immersion / screw-in temperature sensor,**  
**with passive output**

The sleeve sensor / cable sensor **THERMASGARD® HTF** is used to measure temperatures in liquid and gaseous media. It can be used as a duct sensor and - if installed in an immersion sleeve - as an immersion and screw-in sensor. The sleeve length varies, depending on request, from 30..400 mm (standard is 50 mm respectively 200 mm), the cable length is arbitrary (standard is 1.5 m). Depending on application, with silicone, glass fibre, or PVC leads, for two-wire or four-wire connection. For direct, continuous use in liquids, please use our **THE** immersion sleeves (see type table).

**TECHNICAL DATA**

Measuring ranges:	-35...+105 °C <b>PVC</b> , LiYY, 2 x 0.25 mm <sup>2</sup> -50...+180 °C <b>Silicone</b> , SiHF, 2 x 0.25 mm <sup>2</sup> -50...+250 °C <b>PTFE</b> , 2 x 1.0 mm <sup>2</sup> -50...+350 °C <b>glass fibre</b> , 2 x 0.25 mm <sup>2</sup> ends stripped with wire end sleeves (extended measuring range limits optional, depending on connection leads, <b>T<sub>max</sub> Ni1000 = +180 °C,</b> <b>T<sub>max</sub> NTC / Ni1000 TK5000 = +150 °C,</b> <b>T<sub>max</sub> LM235Z = +125 °C</b> )
Sensors / output:	see table, passive (optional also with 2 sensors) <b>(Perfect Sensor Protection with IP68)</b>
Connection type:	2-wire connection (4-wire connection optional)
Testing current:	< 0.6 mA (Pt1000) < 1.0 mA (Pt100) < 0.3 mA (Ni1000, Ni1000 TK5000) < 2.0 mW (NTC xx) 400 µA...5 mA (LM235Z)
Protective tube	sensor sleeve made of stainless steel, <b>V4A</b> (1.4571), Ø = 6 mm <b>HTF50</b> nominal length (NL) = 50 mm <b>HTF200</b> nominal length (NL) = 200 mm (other optional dimensions also available, nominal length (NL) = 30...400 mm)
Connection cable:	cable length (KL) = 1.5 m (optional also 3 m, 5 m, 8 m, 10 m)
Insulating resistance:	≥ 100 MΩ, at +20 °C (500 V DC)
Process connection:	using immersion sleeves <b>THE</b> (see table) or mounting flange, plastic (see table) (optionally in galvanised steel, see chapter Accessories)
Permitted humidity:	< 95 % r.H., non-precipitating air
Protection class:	III (according to EN 60 730)
Protection type:	<b>IP65</b> (according to EN 60 529) <b>sleeve</b> humidity-tight (standard) <b>IP68</b> (according to EN 60 529) <b>sleeve</b> water-tight (optional) <b>IP54</b> (according to EN 60 529) with <b>glass fibre</b> cable (optional)
<b>ACCESSORIES</b>	
<b>MF-06-K</b>	<b>Mounting flange</b> , plastic, 56.8 x 84.3 mm, Ø = 6.2 mm tube gland, T <sub>max</sub> = +100 °C (is <b>not</b> included in scope of delivery)
<b>THE-ms/xx</b>	<b>Immersion sleeve, brass, nickel-plated</b> , Ø = 9 mm, inserted length (EL) = 50 - 250 mm (see table), inner diameter of socket Ø = 5.2 mm, with <b>adjusting screw</b> M12 x 1.5 T <sub>max</sub> = +130 °C, p <sub>max</sub> = 16 bar
<b>THE-VA/xx</b>	<b>Immersion sleeve, stainless steel, V4A</b> (1.4571), Ø = 9 mm, inserted length (EL) = 50 - 400 mm (see table), inner diameter of socket Ø = 5.2 mm, with <b>adjusting screw</b> M12 x 1.5 T <sub>max</sub> = +200 °C, p <sub>max</sub> = 40 bar

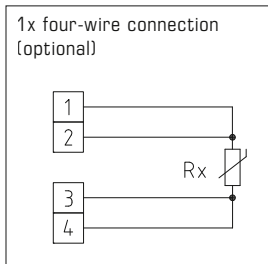
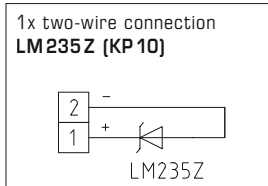
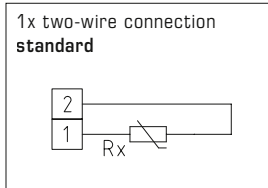

**IP65** (standard)  
 humidity-tight



**IP68** (optional)  
 water-tight  
**Perfect Sensor Protection**



**IP54** (optional)  
 with **glass fibre** cable

**MF-06-K**  
 Mounting flange,  
 plastic  
 (optional)



High-performance encapsulation against  
 vibration, mechanical stress and humidity



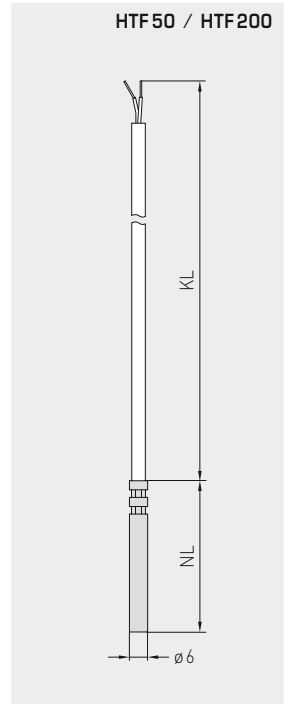
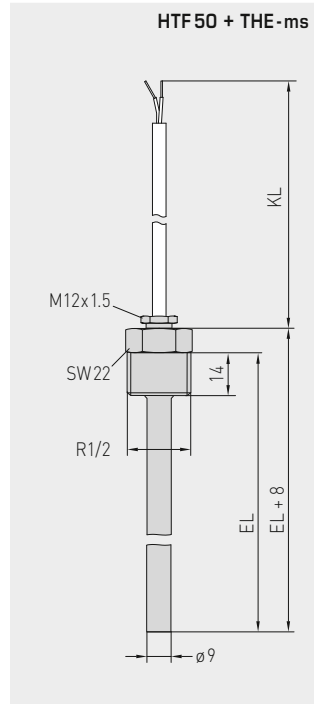
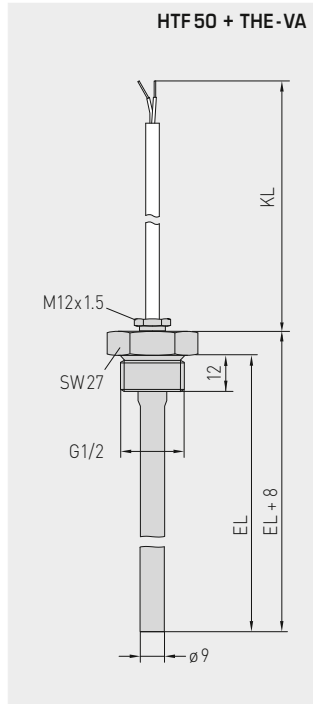
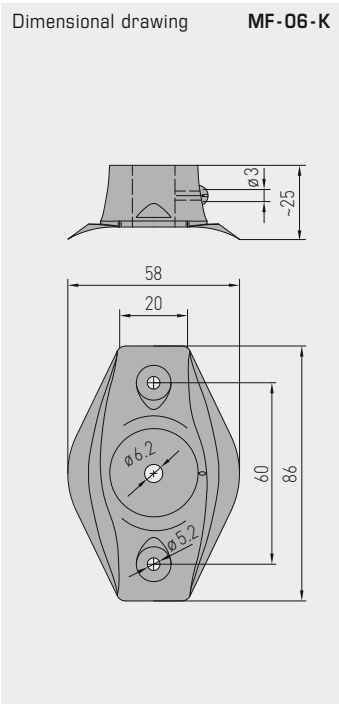

**HTF200 + MF-06-K**  
with accessory mounting flange  
(see type table)  
as duct temperature sensor

**HTF50 + THE-xx**  
with accessory immersion sleeve  
(see type table)  
as immersion / screw-in temperature sensor

**HTF50**  
with PVC / silicone cable  
(standard)

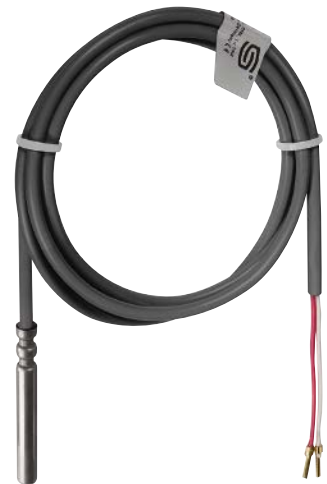
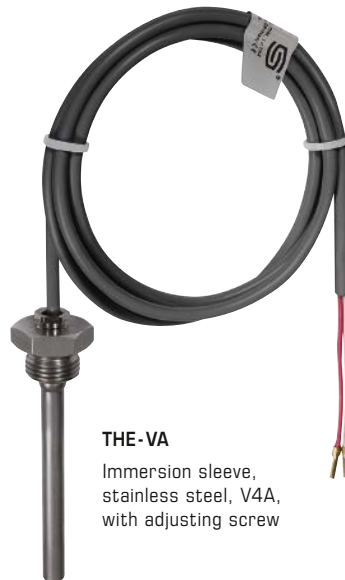

**HTF50**  
with glass fibre cable

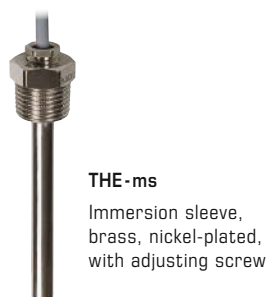

Sleeve sensor / cable temperature sensor  
 duct / immersion / screw-in temperature sensor,  
 with passive output

**THERMASGARD® HTF 50** sleeve sensor / cable temperature sensor (NL = 50 mm)

Type / WG03	Cable material	Cable length	Measuring Range	Protection class	Item No. Sensor	Price
					<b>Pt 100, class B</b>	
<b>HTF50 PT100</b>						
HTF50 Pt100 PVC 1,5M	PVC	1.5 m	-35...+105 °C	IP65 *	1101-6030-1211-110	13,04 €
HTF50 Pt100 Silikon 1,5M	Silicone	1.5 m	-50...+180 °C	IP65 *	1101-6030-1211-120	16,38 €
HTF50 Pt100 PTFE 1,5M	PTFE	1.5 m	-50...+250 °C	IP65 *	1101-6030-1211-140	54,98 €
HTF50 Pt100	Glass Fibre	1.5 m	-50...+350 °C	IP54	1101-6030-1211-050	45,66 €
HTF50 Pt100 PVC 3M	PVC	3 m	-35...+105 °C	IP65 *	1101-6030-1231-110	15,78 €
HTF50 Pt100 Silikon 3M	Silicone	3 m	-50...+180 °C	IP65 *	1101-6030-1231-120	20,43 €
HTF50 Pt100 PVC 5M	PVC	5 m	-35...+105 °C	IP65 *	1101-6030-1251-110	19,42 €
HTF50 Pt100 Silikon 5M	Silicone	5 m	-50...+180 °C	IP65 *	1101-6030-1251-120	25,84 €
HTF50 Pt100 PVC 8M	PVC	8 m	-35...+105 °C	IP65 *	1101-6030-1281-110	24,90 €
HTF50 Pt100 Silikon 8M	Silicone	8 m	-50...+180 °C	IP65 *	1101-6030-1281-120	33,97 €
HTF50 Pt100 PVC 10M	PVC	10 m	-35...+105 °C	IP65 *	1101-6030-1301-110	28,54 €
HTF50 Pt100 Silikon 10M	Silicone	10 m	-50...+180 °C	IP65 *	1101-6030-1301-120	39,40 €
					<b>Pt 1000, class B</b>	
<b>HTF50 PT1000</b>						
HTF50 Pt1000 PVC 1,5M	PVC	1.5 m	-35...+105 °C	IP65 *	1101-6030-5211-110	15,35 €
HTF50 Pt1000 Silikon 1,5M	Silicone	1.5 m	-50...+180 °C	IP65 *	1101-6030-5211-120	18,86 €
HTF50 Pt1000 PTFE 1,5M	PTFE	1.5 m	-50...+250 °C	IP65 *	1101-6030-5211-140	55,11 €
HTF50 Pt1000	Glass Fibre	1.5 m	-50...+350 °C	IP54	1101-6030-5211-050	45,66 €
HTF50 Pt1000 PVC 3M	PVC	3 m	-35...+105 °C	IP65 *	1101-6030-5231-110	18,09 €
HTF50 Pt1000 Silikon 3M	Silicone	3 m	-50...+180 °C	IP65 *	1101-6030-5231-120	22,93 €
HTF50 Pt1000 PVC 5M	PVC	5 m	-35...+105 °C	IP65 *	1101-6030-5251-110	21,73 €
HTF50 Pt1000 Silikon 5M	Silicone	5 m	-50...+180 °C	IP65 *	1101-6030-5251-120	28,34 €
HTF50 Pt1000 PVC 8M	PVC	8 m	-35...+105 °C	IP65 *	1101-6030-5281-110	27,21 €
HTF50 Pt1000 Silikon 8M	Silicone	8 m	-50...+180 °C	IP65 *	1101-6030-5281-120	36,46 €
HTF50 Pt1000 PVC 10M	PVC	10 m	-35...+105 °C	IP65 *	1101-6030-5301-110	30,86 €
HTF50 Pt1000 Silikon 10M	Silicone	10 m	-50...+180 °C	IP65 *	1101-6030-5301-120	41,87 €
					<b>Pt 1000 A, class A-TGA</b>	
<b>HTF50 PT1000 A</b>						
HTF50 Pt1000A PVC 1,5M	PVC	1.5 m	-35...+105 °C	IP65 *	1101-6030-6211-110	22,51 €
HTF50 Pt1000A Silikon 1,5M	Silicone	1.5 m	-50...+180 °C	IP65 *	1101-6030-6211-120	25,86 €
					<b>Ni 1000</b>	
<b>HTF50 NI1000</b>						
HTF50 Ni1000 PVC 1,5M	PVC	1.5 m	-35...+105 °C	IP65 *	1101-6030-9211-110	14,91 €
HTF50 Ni1000 Silikon 1,5M	Silicone	1.5 m	-50...+180 °C	IP65 *	1101-6030-9211-120	18,57 €
HTF50 Ni1000 PVC 3M	PVC	3 m	-35...+105 °C	IP65 *	1101-6030-9231-110	17,66 €
HTF50 Ni1000 Silikon 3M	Silicone	3 m	-50...+180 °C	IP65 *	1101-6030-9231-120	22,62 €
HTF50 Ni1000 PVC 5M	PVC	5 m	-35...+105 °C	IP65 *	1101-6030-9251-110	21,31 €
HTF50 Ni1000 Silikon 5M	Silicone	5 m	-50...+180 °C	IP65 *	1101-6030-9251-120	28,03 €
HTF50 Ni1000 PVC 8M	PVC	8 m	-35...+105 °C	IP65 *	1101-6030-9281-110	26,78 €
HTF50 Ni1000 Silikon 8M	Silicone	8 m	-50...+180 °C	IP65 *	1101-6030-9281-120	36,16 €
HTF50 Ni1000 PVC 10M	PVC	10 m	-35...+105 °C	IP65 *	1101-6030-9301-110	30,42 €
HTF50 Ni1000 Silikon 10M	Silicone	10 m	-50...+180 °C	IP65 *	1101-6030-9301-120	41,57 €
					<b>Ni 1000 TK 5000</b>	
<b>HTF50 NITK</b>						
HTF50 NiTK PVC 1,5M	PVC	1.5 m	-35...+105 °C	IP65 *	1101-6031-0211-110	18,80 €
HTF50 NiTK Silikon 1,5M	Silicone	1.5 m	-50...+150 °C	IP65 *	1101-6031-0211-120	22,18 €
HTF50 NiTK PVC 3M	PVC	3 m	-35...+105 °C	IP65 *	1101-6031-0231-110	21,55 €
HTF50 NiTK Silikon 3M	Silicone	3 m	-50...+150 °C	IP65 *	1101-6031-0231-120	26,25 €
HTF50 NiTK PVC 5M	PVC	5 m	-35...+105 °C	IP65 *	1101-6031-0251-110	25,20 €
HTF50 NiTK Silikon 5M	Silicone	5 m	-50...+150 °C	IP65 *	1101-6031-0251-120	31,65 €
HTF50 NiTK PVC 8M	PVC	8 m	-35...+105 °C	IP65 *	1101-6031-0281-110	30,67 €
HTF50 NiTK Silikon 8M	Silicone	8 m	-50...+150 °C	IP65 *	1101-6031-0281-120	39,79 €
HTF50 NiTK PVC 10M	PVC	10 m	-35...+105 °C	IP65 *	1101-6031-0301-110	34,31 €
HTF50 NiTK Silikon 10M	Silicone	10 m	-50...+150 °C	IP65 *	1101-6031-0301-120	45,20 €
					<b>LM235Z</b>	
<b>HTF50 LM235Z</b>						
HTF50 LM235Z PVC 1,5M	PVC	1.5 m	-35...+105 °C	IP65 *	1101-6032-1211-110	13,35 €
HTF50 LM235Z Silikon 1,5M	Silicone	1.5 m	-40...+125 °C	IP65 *	1101-6032-1211-120	16,99 €
HTF50 LM235Z PVC 3M	PVC	3 m	-35...+105 °C	IP65 *	1101-6032-1231-110	16,08 €
HTF50 LM235Z Silikon 3M	Silicone	3 m	-40...+125 °C	IP65 *	1101-6032-1231-120	21,04 €
HTF50 LM235Z PVC 5M	PVC	5 m	-35...+105 °C	IP65 *	1101-6032-1251-110	19,74 €
HTF50 LM235Z Silikon 5M	Silicone	5 m	-40...+125 °C	IP65 *	1101-6032-1251-120	26,45 €
HTF50 LM235Z PVC 8M	PVC	8 m	-35...+105 °C	IP65 *	1101-6032-1281-110	25,21 €
HTF50 LM235Z Silikon 8M	Silicone	8 m	-40...+125 °C	IP65 *	1101-6032-1281-120	34,59 €
HTF50 LM235Z PVC 10M	PVC	10 m	-35...+105 °C	IP65 *	1101-6032-1301-110	28,86 €
HTF50 LM235Z Silikon 10M	Silicone	10 m	-40...+125 °C	IP65 *	1101-6032-1301-120	40,00 €

Continued on next page ...



THERMASGARD® HTF 50 sleeve sensor / cable temperature sensor (NL = 50 mm)						
Type / WG03	Cable material	Cable length	Measuring Range	Protection class	Item No. Sensor	Price
<b>HTF50 NTC1.8K</b>					<b>NTC 1.8K</b>	
HTF50 NTC1,8K PVC 1,5M	PVC	1.5 m	-35...+105°C	IP65 *	1101-6031-2211-110	12,61 €
HTF50 NTC1,8K Silikon 1,5M	Silicone	1.5 m	-50...+150°C	IP65 *	1101-6031-2211-120	14,49 €
HTF50 NTC1,8K PVC 3M	PVC	3 m	-35...+105°C	IP65 *	1101-6031-2231-110	15,36 €
HTF50 NTC1,8K Silikon 3M	Silicone	3 m	-50...+150°C	IP65 *	1101-6031-2231-120	18,57 €
HTF50 NTC1,8K PVC 5M	PVC	5 m	-35...+105°C	IP65 *	1101-6031-2251-110	19,01 €
HTF50 NTC1,8K Silikon 5M	Silicone	5 m	-50...+150°C	IP65 *	1101-6031-2251-120	23,98 €
HTF50 NTC1,8K PVC 8M	PVC	8 m	-35...+105°C	IP65 *	1101-6031-2281-110	24,47 €
HTF50 NTC1,8K Silikon 8M	Silicone	8 m	-50...+150°C	IP65 *	1101-6031-2281-120	32,09 €
HTF50 NTC1,8K PVC 10M	PVC	10 m	-35...+105°C	IP65 *	1101-6031-2301-110	28,12 €
HTF50 NTC1,8K Silikon 10M	Silicone	10 m	-50...+150°C	IP65 *	1101-6031-2301-120	37,51 €
<b>HTF50 NTC10K</b>					<b>NTC 10K</b>	
HTF50 NTC10K PVC 1,5M	PVC	1.5 m	-35...+105°C	IP65 *	1101-6031-5211-110	12,61 €
HTF50 NTC10K Silikon 1,5M	Silicone	1.5 m	-50...+150°C	IP65 *	1101-6031-5211-120	14,49 €
HTF50 NTC10K PVC 3M	PVC	3 m	-35...+105°C	IP65 *	1101-6031-5231-110	15,36 €
HTF50 NTC10K Silikon 3M	Silicone	3 m	-50...+150°C	IP65 *	1101-6031-5231-120	18,57 €
HTF50 NTC10K PVC 5M	PVC	5 m	-35...+105°C	IP65 *	1101-6031-5251-110	19,01 €
HTF50 NTC10K Silikon 5M	Silicone	5 m	-50...+150°C	IP65 *	1101-6031-5251-120	23,98 €
HTF50 NTC10K PVC 8M	PVC	8 m	-35...+105°C	IP65 *	1101-6031-5281-110	24,47 €
HTF50 NTC10K Silikon 8M	Silicone	8 m	-50...+150°C	IP65 *	1101-6031-5281-120	32,09 €
HTF50 NTC10K PVC 10M	PVC	10 m	-35...+105°C	IP65 *	1101-6031-5301-110	28,12 €
HTF50 NTC10K Silikon 10M	Silicone	10 m	-50...+150°C	IP65 *	1101-6031-5301-120	37,51 €
<b>HTF50 NTC20K</b>					<b>NTC 20K</b>	
HTF50 NTC20K PVC 1,5M	PVC	1.5 m	-35...+105°C	IP65 *	1101-6031-6211-110	12,61 €
HTF50 NTC20K Silikon 1,5M	Silicone	1.5 m	-50...+150°C	IP65 *	1101-6031-6211-120	14,49 €
HTF50 NTC20K PVC 3M	PVC	3 m	-35...+105°C	IP65 *	1101-6031-6231-110	15,36 €
HTF50 NTC20K Silikon 3M	Silicone	3 m	-50...+150°C	IP65 *	1101-6031-6231-120	18,57 €
HTF50 NTC20K PVC 5M	PVC	5 m	-35...+105°C	IP65 *	1101-6031-6251-110	19,01 €
HTF50 NTC20K Silikon 5M	Silicone	5 m	-50...+150°C	IP65 *	1101-6031-6251-120	23,98 €
HTF50 NTC20K PVC 8M	PVC	8 m	-35...+105°C	IP65 *	1101-6031-6281-110	24,47 €
HTF50 NTC20K Silikon 8M	Silicone	8 m	-50...+150°C	IP65 *	1101-6031-6281-120	32,09 €
HTF50 NTC20K PVC 10M	PVC	10 m	-35...+105°C	IP65 *	1101-6031-6301-110	28,12 €
HTF50 NTC20K Silikon 10M	Silicone	10 m	-50...+150°C	IP65 *	1101-6031-6301-120	37,51 €
Extra charge:	* Protection type <b>IP68</b> (Sensor sleeve watertight compound-filled) Other sensors optional Cable length (KL) 3 m, 5 m, 8 m, 10 m (standard lengths) Connection type <b>4-wire</b> (4-conductor)					3,24 € on request on request on request
For special orders please specify: (possible for 25 or more pieces)	Type sensor length (NL), sensor, cable material, connection type, cable length (KL), protection type e.g. HTF-30mm, Pt1000, PVC, 2-wire, 10m, IP68; HTF-50mm, Ni1000 TK5000, silicon, 4-wire, 5m, IP65					

**HTF 50**  
(NL = 50 mm)  
with PVC / silicone cable

**HTF 50**  
(NL = 50 mm)  
with glass fibre cable



- IP 65** (standard)  
humidity-tight
- IP 68** (optional)  
water-tight  
**Perfect Sensor Protection**
- IP 54** (optional)  
with glass fibre cable





Sleeve sensor / cable temperature sensor  
 duct / immersion / screw-in temperature sensor,  
 with passive output

**THERMASGARD® HTF 200** sleeve sensor / cable temperature sensor (NL = 200 mm)

Type / WG03	Cable material	Cable length	Measuring Range	Protection class	Item No. Sensor	Price
<b>HTF200 PT100</b>					<b>Pt 100, class B</b>	
HTF200 Pt100 PVC 1,5M	PVC	1.5 m	-35...+105 °C	IP65 *	1101-6090-1211-110	19,40 €
HTF200 Pt100 Silikon 1,5M	Silicone	1.5 m	-50...+180 °C	IP65 *	1101-6090-1211-120	23,04 €
<b>HTF200 PT1000</b>					<b>Pt 1000, class B</b>	
HTF200 Pt1000 PVC 1,5M	PVC	1.5 m	-35...+105 °C	IP65 *	1101-6090-5211-110	19,40 €
HTF200 Pt1000 Silikon 1,5M	Silicone	1.5 m	-50...+180 °C	IP65 *	1101-6090-5211-120	23,04 €
<b>HTF200 PT1000 A</b>					<b>Pt 1000 A, class A-TGA</b>	
HTF200 Pt1000A PVC 1,5M	PVC	1.5 m	-35...+105 °C	IP65 *	1101-6090-6211-110	26,40 €
HTF200 Pt1000A Silikon 1,5M	Silicone	1.5 m	-50...+180 °C	IP65 *	1101-6090-6211-120	30,06 €
<b>HTF200 Ni1000</b>					<b>Ni 1000</b>	
HTF200 Ni1000 PVC 1,5M	PVC	1.5 m	-35...+105 °C	IP65 *	1101-6090-9211-110	19,77 €
HTF200 Ni1000 Silikon 1,5M	Silicone	1.5 m	-50...+180 °C	IP65 *	1101-6090-9211-120	23,04 €
<b>HTF200 NiTK</b>					<b>Ni 1000 TK 5000</b>	
HTF200 NiTK PVC 1,5M	PVC	1.5 m	-35...+105 °C	IP65 *	1101-6091-0211-110	20,74 €
HTF200 NiTK Silikon 1,5M	Silicone	1.5 m	-50...+150 °C	IP65 *	1101-6091-0211-120	24,01 €
<b>HTF200 LM235Z</b>					<b>LM 235 Z</b>	
HTF200 LM235Z PVC 1,5M	PVC	1.5 m	-35...+105 °C	IP65 *	1101-6092-1211-110	20,00 €
HTF200 LM235Z Silikon 1,5M	Silicone	1.5 m	-40...+125 °C	IP65 *	1101-6092-1211-120	23,65 €
<b>HTF200 NTC1,8K</b>					<b>NTC 1.8K</b>	
HTF200 NTC1,8K PVC 1,5M	PVC	1.5 m	-35...+105 °C	IP65 *	1101-6091-2211-110	19,40 €
HTF200 NTC1,8K Silikon 1,5M	Silicone	1.5 m	-50...+150 °C	IP65 *	1101-6091-2211-120	23,04 €
<b>HTF200 NTC10K</b>					<b>NTC 10K</b>	
HTF200 NTC10K PVC 1,5M	PVC	1.5 m	-35...+105 °C	IP65 *	1101-6091-5211-110	19,40 €
HTF200 NTC10K Silikon 1,5M	Silicone	1.5 m	-50...+150 °C	IP65 *	1101-6091-5211-120	23,04 €
<b>HTF200 NTC20K</b>					<b>NTC 20K</b>	
HTF200 NTC20K PVC 1,5M	PVC	1.5 m	-35...+105 °C	IP65 *	1101-6091-6211-110	19,40 €
HTF200 NTC20K Silikon 1,5M	Silicone	1.5 m	-50...+150 °C	IP65 *	1101-6091-6211-120	23,04 €
Extra charge:	* Protection type <b>IP68</b> (Sensor sleeve watertight compound-filled) Other sensors optional <b>Cable length (KL)</b> 3 m, 5 m, 8 m, 10 m (standard lengths) Connection type <b>4-wire</b> (4-conductor)					3,24 € on request on request on request
For special orders please specify: (possible for 25 or more pieces)	Type sensor length (NL), sensor, cable material, connection type, cable length (KL), protection type e. g. HTF-200 mm, Pt1000, PVC, 2-wire, 10 m, IP68; HTF-400 mm, Ni1000 TK5000, silicon, 4-wire, 5 m, IP65					

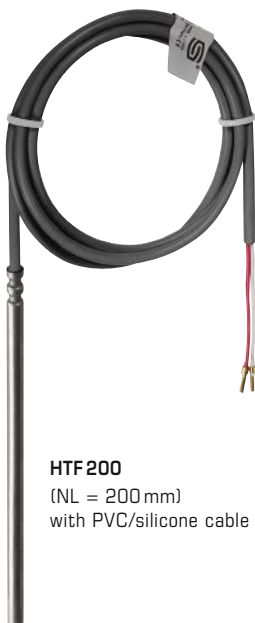

**HTF 200**  
 (NL = 200 mm)  
 with PVC/silicone cable



**IP65** (standard)  
 humidity-tight



**IP68** (optional)  
 water-tight  
**Perfect Sensor Protection**

THERMASGARD® HTF 50 accessory as immersion / screw-in sensor temperature sensor (ESTF)				
Type / WG01	Description		Item No.	Price
<b>THE -ms / xx</b>				
	Immersion sleeve, brass, nickel-plated, Ø 9 mm, inner diameter of socket Ø = 5.2 mm, with adjusting screw M12 x 1.5			
THE-MS 50MM	p <sub>max</sub> = 16 bar, T <sub>max</sub> = +130 °C	EL = 50 mm	7100-0011-6010-002	9,96 €
THE-MS 100MM	p <sub>max</sub> = 16 bar, T <sub>max</sub> = +130 °C	EL = 100 mm	7100-0011-6020-002	10,76 €
THE-MS 150MM	p <sub>max</sub> = 16 bar, T <sub>max</sub> = +130 °C	EL = 150 mm	7100-0011-6030-002	11,16 €
THE-MS 200MM	p <sub>max</sub> = 16 bar, T <sub>max</sub> = +130 °C	EL = 200 mm	7100-0011-6040-002	11,94 €
THE-MS 250MM	p <sub>max</sub> = 16 bar, T <sub>max</sub> = +130 °C	EL = 250 mm	7100-0011-6050-002	13,38 €
<b>THE -VA / xx</b>				
	Immersion sleeve, stainless steel, V4A (1.4571), Ø 9 mm, inner diameter of socket Ø = 5.2 mm, with adjusting screw M12 x 1.5			
THE-VA 50MM	p <sub>max</sub> = 40 bar, T <sub>max</sub> = +200 °C	EL = 50 mm	7100-0012-6010-002	19,71 €
THE-VA 100MM	p <sub>max</sub> = 40 bar, T <sub>max</sub> = +200 °C	EL = 100 mm	7100-0012-6020-002	21,77 €
THE-VA 150MM	p <sub>max</sub> = 40 bar, T <sub>max</sub> = +200 °C	EL = 150 mm	7100-0012-6030-002	23,38 €
THE-VA 200MM	p <sub>max</sub> = 40 bar, T <sub>max</sub> = +200 °C	EL = 200 mm	7100-0012-6040-002	24,66 €
THE-VA 250MM	p <sub>max</sub> = 40 bar, T <sub>max</sub> = +200 °C	EL = 250 mm	7100-0012-6050-002	30,65 €
THE-VA 300MM	p <sub>max</sub> = 40 bar, T <sub>max</sub> = +200 °C	EL = 300 mm	7100-0012-6060-002	32,02 €
THE-VA 400MM	p <sub>max</sub> = 40 bar, T <sub>max</sub> = +200 °C	EL = 400 mm	7100-0012-6080-002	33,06 €
xx = (EL)	Other installation lengths on request			

**HTF 50**  
(NL = 50 mm)  
with THE immersion sleeve  
as immersion / screw-in temperature sensor



**THE -ms**  
Immersion sleeve,  
brass, nickel-plated,  
with adjusting screw

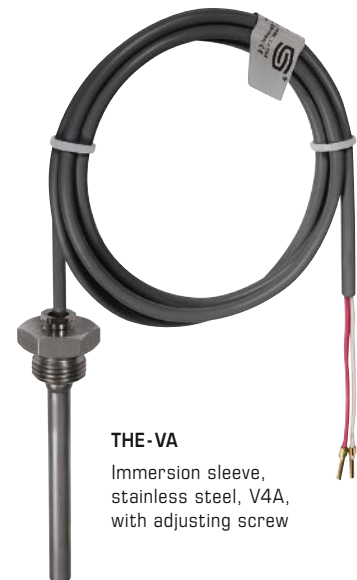

**THE -VA**  
Immersion sleeve,  
stainless steel, V4A,  
with adjusting screw

**MF-06-K**  
Mounting flange,  
plastic  
(optional)



THERMASGARD® HTF 50 accessories (standard)				
THERMASGARD® HTF 200 accessories (standard)				
Type / WG01	Description	T <sub>max</sub>	Item No.	Price
MF				
MF-06-K	Mounting flange plastic, 56.8 x 84.3 mm, Ø 6.2 mm tube gland (not included in scope of delivery)	+100 °C	7100-0030-1000-000	5,83 €
Note:	For further information see last chapter!			

Surface contact temperature sensors /  
surface temperature sensors,  
with passive output

Small surface contact resistance thermometer in aluminium enclosure (cable sensor).  
The surface sensor **THERMASGARD® OFTF** is used for temperature detection on flat or slightly convex surfaces, for instance for surface temperature measurement at windows, for monitoring formation of condensate, or as heating surface sensor, e.g. at windows or walls.

**TECHNICAL DATA**

Measuring range:	-30...+105 °C
Sensors / output:	see table, passive <b>(Perfect Sensor Protection with IP68)</b>
Connection type:	2-wire connection
Testing current:	< 0.6 mA (Pt1000) < 1.0 mA (Pt100) < 0.3 mA (Ni1000, Ni1000 TK5000) < 2.0 mW (NTC xx) 400 µA...5 mA (LM235Z)
Process connection:	attachment to the surface to be measured through fixing hole in the sensor head or by suitable adhesive
Protective sleeve:	aluminium
Dimensions:	8 x 8 x 50 mm
Connecting cable:	PVC; 1.5 m, LiYY, 2 x 0.25 mm <sup>2</sup> , ends stripped with wire end sleeves (optional with silicone cable SiHF, up to +180 °C)
Insulating resistance:	≥ 100 MΩ, at +20 °C (500 V DC)
Permissible air humidity:	< 95 % r. H., non-precipitating air
Protection class:	III (according to EN 60 730)
Protection type:	<b>IP65</b> (according to EN 60 529) <b>sleeve</b> humidity-tight (standard) <b>IP68</b> (according to EN 60 529) <b>sleeve</b> water-tight (optional)

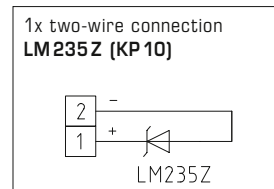
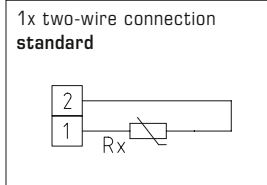

**IP65** (standard)  
humidity-tight



**IP68** (optional)  
water-tight  
**Perfect Sensor Protection**

High-performance encapsulation against  
vibration, mechanical stress and humidity



Dimensional drawing

OFTF

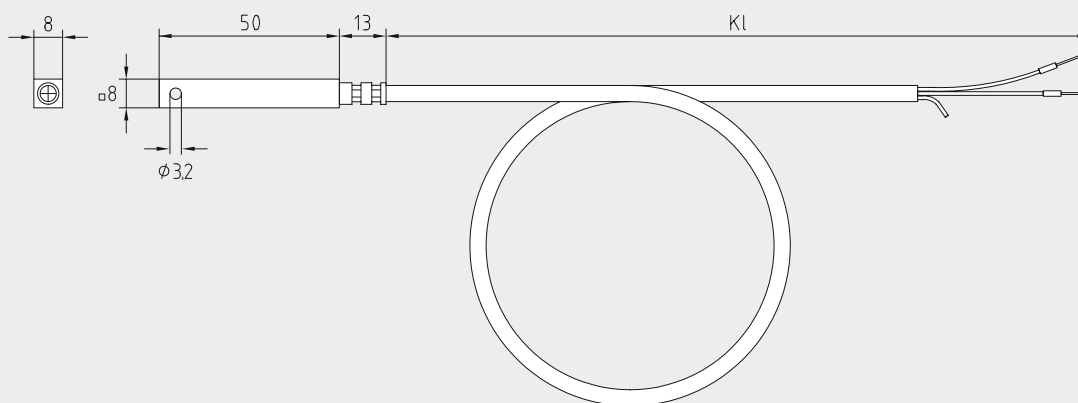



OUTF

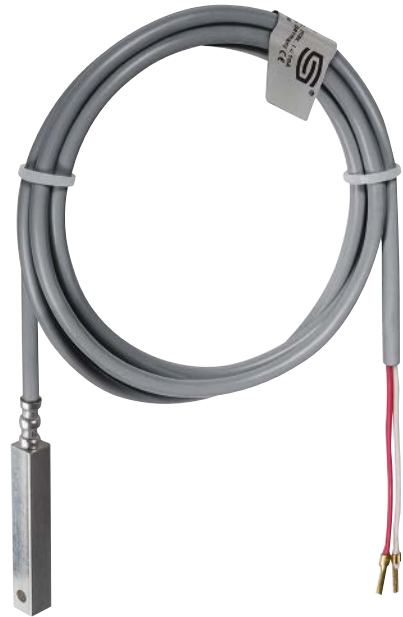

THERMASGARD® OUTF Surface contact temperature sensors / surface temperature sensors			
Type / WG03	Sensor / output	Item No.	Price
<b>OUTF</b>		<b>IP65</b>	
OUTF Pt100 PVC 1,5M	Pt100 (according to DIN EN 60 751, class B)	1101-6010-1211-110	<b>35,23 €</b>
OUTF Pt1000 PVC 1,5M	Pt1000 (according to DIN EN 60 751, class B)	1101-6010-5211-110	<b>35,23 €</b>
OUTF Ni1000 PVC 1,5M	Ni1000 (according to DIN EN 43 760, class B, TCR = 6180 ppm / K)	1101-6010-9211-110	<b>37,27 €</b>
OUTF NiTK PVC 1,5M	Ni1000 TK5000 (TCR = 5000 ppm / K), LG - Ni1000	1101-6011-0211-110	<b>41,21 €</b>
OUTF LM235Z PVC 1,5M	LM235Z (TCR = 10 mV / K; 2.73 V at 0 °C), KP10	1101-6012-1211-110	<b>35,91 €</b>
OUTF NTC1,8K PVC 1,5M	NTC 1.8K	1101-6011-2211-110	<b>33,88 €</b>
OUTF NTC10K PVC 1,5M	NTC 10K	1101-6011-5211-110	<b>33,88 €</b>
OUTF NTC20K PVC 1,5M	NTC 20K	1101-6011-6211-110	<b>33,88 €</b>
Extra charge:	Protection type <b>IP68</b> (sensor sleeve watertight compound-filled) 2-wire connecting leads ( <b>PVC/silicone</b> ) per running metre 4-wire connecting leads ( <b>PVC/silicone</b> ) per running metre	on request on request	<b>3,24 €</b>
For special orders please specify:	Type, sensor type, cable length e.g. OUTF Pt100, 3m; OUTF Pt100 1 / 3 DIN, 4m; OUTF KTY 81-210, 6m		

Surface contact temperature sensors / tube contact temperature sensors, including strap, with passive output

**THERMASGARD® ALTF 1** surface contact sensors are electric contact thermometers and are used for measuring surface temperatures of solids, having at least one so-called contact area that is brought into contact with the surface to be measured. The surface contact temperature sensor ALTF 1 with connection cable and passive output determines the temperature of a medium flowing inside a pipe (e.g. water temperature) via the surface temperature. ALTF 1 is a tube contact resistance thermometer with strap and axial feeler tube for measuring temperature on piping and tubes (e.g. cold-water and hot-water), or at heating sections for heating system control.

1x two-wire connection standard

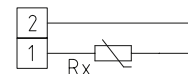

1x two-wire connection LM235Z (KP 10)

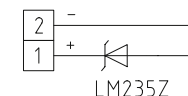

1x four-wire connection (optional)

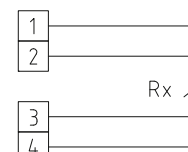

**TECHNICAL DATA**

Measuring range:	-35...+105 °C PVC -35...+180 °C silicone (T <sub>max</sub> NTC = +150 °C, T <sub>max</sub> LM235Z = +125 °C)
Sensors / output:	see table, passive (optional also with 2 sensors) <b>(Perfect Sensor Protection with IP68)</b>
Connection type:	2-wire connection (4-wire connection optional)
Testing current:	< 0.6 mA (Pt1000) < 1.0 mA (Pt100) < 0.3 mA (Ni1000, Ni1000 TK5000) < 2.0 mW (NTC xx) 400 µA...5 mA (LM235Z)
Connecting cable:	PVC; 1.5 m, LiYY, 2 x 0.25 mm <sup>2</sup> or silicone, SiHF, 2 x 0.25 mm <sup>2</sup> ends stripped, with wire end sleeves
Insulating resistance:	≥ 100 MΩ, at +20 °C (500 V DC)
Sensor protection:	pipe feeder made of stainless steel <b>V4A</b> (1.4571), Ø = 6 mm, L = 50 mm
Process connection:	with <b>endless strap</b> with metal tightener (included in the scope of delivery) Ø = 13 - 92 mm (¼ - 3"); length 300 mm
Humidity:	< 95 % r. H., non-precipitating air
Protection class:	III (according to EN 60 730)
Protection type:	<b>IP65</b> (according to EN 60 529) <b>sleeve</b> humidity-tight (standard) <b>IP68</b> (according to EN 60 529) <b>sleeve</b> water-tight (optional)



**IP65** (standard)  
humidity-tight



**IP68** (optional)  
water-tight  
**Perfect Sensor Protection**

**THERMASGARD® ALTF 1** Surface contact temperature sensors / tube contact temperature sensors (PVC)

Type / WG03	Sensor / Output	Item No.	Price
<b>ALTF 1 xx PVC</b>		<b>IP65, PVC</b>	
ALTF1 Pt100 PVC 1,5M	Pt100 (according to DIN EN 60 751, class B)	1101-6020-1211-110	<b>19,29 €</b>
ALTF1 Pt1000 PVC 1,5M	Pt1000 (according to DIN EN 60 751, class B)	1101-6020-5211-110	<b>19,29 €</b>
ALTF1 Ni1000 PVC 1,5M	Ni1000 (according to DIN EN 43 760, class B, TCR = 6180 ppm / K)	1101-6020-9211-110	<b>20,00 €</b>
ALTF1 NiTK PVC 1,5M	Ni1000 TK5000 (TCR = 5000 ppm / K), LG - Ni1000	1101-6021-0211-110	<b>20,74 €</b>
ALTF1 LM235Z PVC 1,5M	LM235Z (TCR = 10 mV / K; 2.73 V at 0 °C), KP10	1101-6022-1211-110	<b>20,37 €</b>
ALTF1 NTC1,8K PVC 1,5M	NTC 1.8K	1101-6021-2211-110	<b>19,77 €</b>
ALTF1 NTC10K PVC 1,5M	NTC 10K	1101-6021-5211-110	<b>19,77 €</b>
ALTF1 NTC20K PVC 1,5M	NTC 20K	1101-6021-6211-110	<b>19,77 €</b>
Note:	including strap, connecting cable <b>PVC</b> (KL = 1.5 m)		
Extra charge:	Protection type <b>IP68</b> (Sensor sleeve watertight compound-filled) 2-wire connecting leads, per running meter ( <b>PVC</b> ) Other sensors optional	on request on request	<b>3,24 €</b>

**ACCESSORIES**

<b>WLP-1</b>	Heat-conductive paste, silicone-free	7100-0060-1000-000	<b>3,22 €</b>
--------------	--------------------------------------	--------------------	---------------









S+S REGELTECHNIK

**THERMASGARD® ALTF 2**  
**THERMASGARD® ALTF 02**

Surface contact temperature sensors /  
tube contact temperature sensors, including strap,  
with passive output

Dimensional drawing

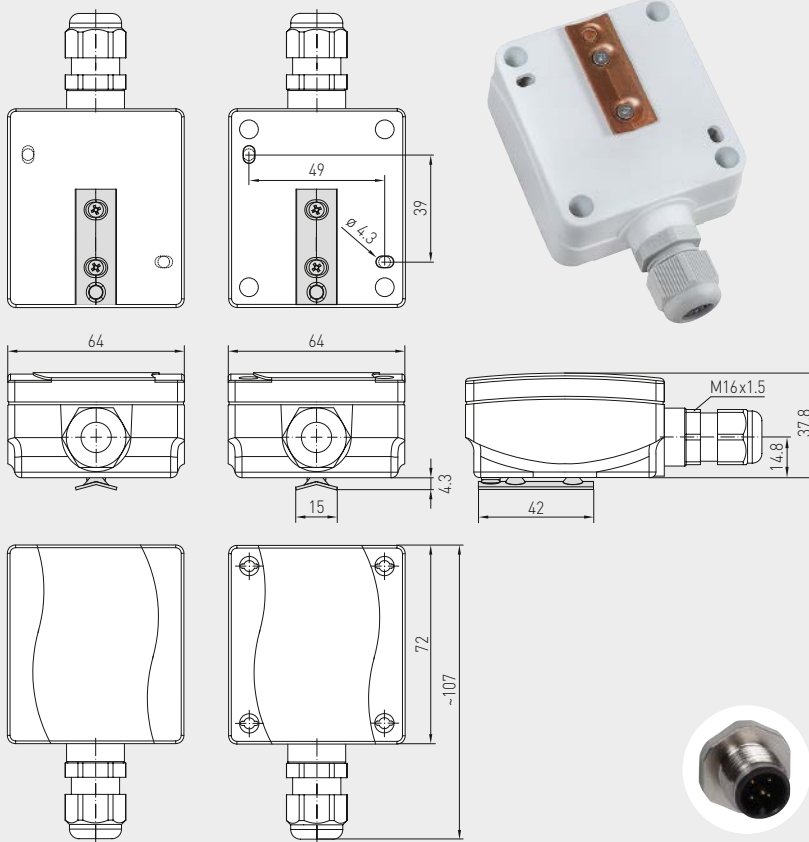

ALTF 2  
ALTF 02

with snap-on lid

with quick-locking  
screws

M12 connector  
(optional on request)



ALTF 02  
with snap-on lid  
(IP54)



ALTF 2  
with quick-locking  
screws  
(IP65)

High-performance encapsulation against  
vibration, mechanical stress and humidity



**THERMASGARD® ALTF 2** Surface contact temperature sensors / tube contact temperature sensors, *Premium*  
including strap, with quick-locking screws

Type / WG03	Sensor / Output	Item No.	Price
<b>ALTF 2</b>		<b>IP 65</b>	
ALTF2 Pt100	Pt100 (according to DIN EN 60 751, class B)	1101-1020-1003-000	<b>23,94 €</b>
ALTF2 Pt1000	Pt1000 (according to DIN EN 60 751, class B)	1101-1020-5001-000	<b>24,62 €</b>
ALTF2 Pt1000A	Pt1000 (according to VDI / VDE 3512, class A-TGA)	1101-1020-6003-000	<b>28,00 €</b>
ALTF2 Ni1000	Ni1000 (according to DIN EN 43 760, class B, TCR = 6180 ppm / K)	1101-1020-9001-000	<b>24,28 €</b>
ALTF2 NiTK	Ni1000 TK5000 (TCR = 5000 ppm / K), LG-Ni1000	1101-1021-0001-000	<b>28,46 €</b>
ALTF2 LM235Z	LM235Z (TCR = 10 mV / K; 2.73 V at 0 °C), KP10	1101-1022-1001-000	<b>23,49 €</b>
ALTF2 NTC1,8K	NTC 1.8K	1101-1021-2001-000	<b>20,43 €</b>
ALTF2 NTC10K	NTC 10K	1101-1021-5001-000	<b>20,43 €</b>
ALTF2 NTC20K	NTC 20K	1101-1021-6001-000	<b>20,43 €</b>
Extra charge:	two or other sensors optional cable connection with <b>M12 connector</b> according to DIN EN 61076-2-101	on request on request	

**ACCESSORIES**

<b>WLP-1</b>	Heat-conductive paste, silicone-free	7100-0060-1000-000	<b>3,22 €</b>
--------------	--------------------------------------	--------------------	---------------

**Pendulum room temperature sensors  
with passive output**

Resistance thermometer **THERMASGARD® RPTF 1** with passive output is specifically used for temperature detection in larger rooms and halls. Due to the measuring method employed by this pendulum room temperature sensor in combination with its positioning in the room, excellent and room-representative measuring results are achieved as ambient air of the room is steadily washing around the sensor.

**TECHNICAL DATA**

Measuring range:	-5...+60 °C
Sensors / output:	see table, passive (optional also with two sensors)
Sensor protection:	<b>plastic</b> sinter filter, Ø 16 mm, L = 35 mm, exchangeable (optional <b>metal</b> sinter filter, Ø 16 mm, L = 32 mm)
Connection type:	2-wire connection (4-wire connection optional)
Testing current:	< 0.6 mA (Pt1000) < 1.0 mA (Pt100) < 0.3 mA (Ni1000, Ni1000 TK5000) < 2.0 mW (NTC xx) 400 µA...5 mA (LM235Z)
Connection cable:	PVC, H03VV-F, 2 x 0.5 mm <sup>2</sup> , ends stripped with wire end sleeves KL = approx. 1.5 m (other lengths optional)
Protective tube:	<b>stainless steel V2A</b> (1.4301), Ø=16 mm, NL = 142 mm
Insulating resistance:	≥ 100 MΩ, at +20 °C (500 V DC)
Humidity:	< 95% r. H.
Protection class:	III (according to EN 60 730)
Protection type:	<b>IP 65</b> (according to EN 60 529)

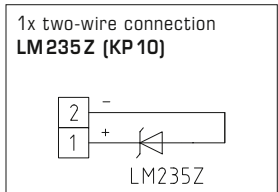
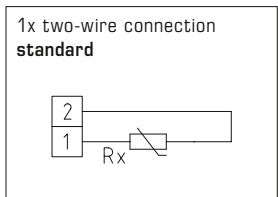
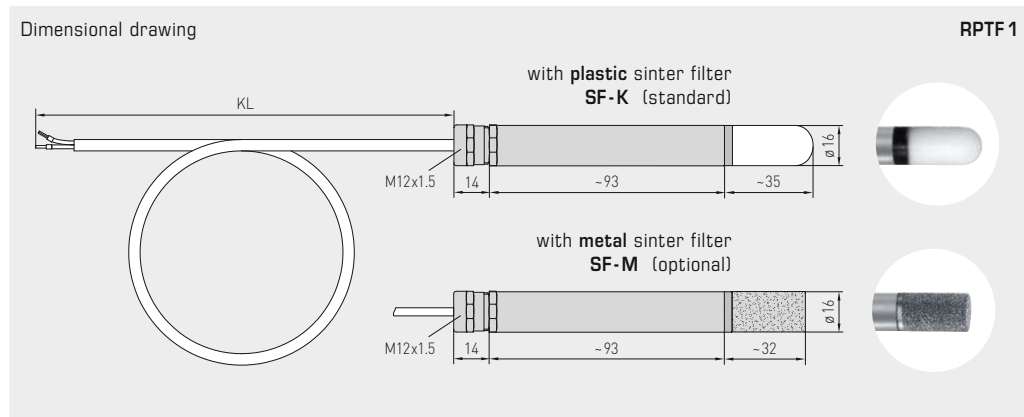
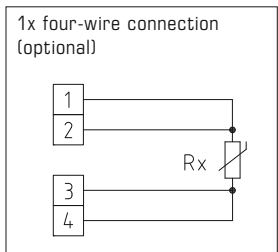
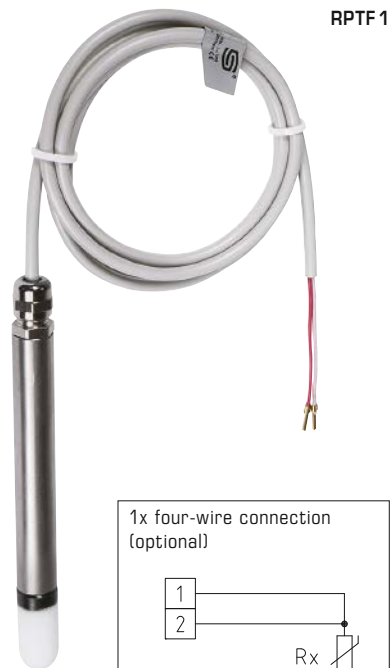

**THERMASGARD® RPTF 1** Pendulum room temperature sensors (with metal sleeve)

Type / WG03	Sensor / Output	Item No.	Price
<b>RPTF 1</b>		<b>IP 65</b>	
RPTF1 Pt100 PVC 1,5M	Pt100 (according to DIN EN 60 751, class B)	1101-6060-1211-010	<b>55,89 €</b>
RPTF1 Pt1000 PVC 1,5M	Pt1000 (according to DIN EN 60 751, class B)	1101-6060-5211-010	<b>58,82 €</b>
RPTF1 Ni1000 PVC 1,5M	Ni1000 (according to DIN EN 43 760, class B, TCR = 6180 ppm / K)	1101-6060-9211-010	<b>57,83 €</b>
RPTF1 NiTK PVC 1,5M	Ni1000 TK5000 (TCR = 5000 ppm / K), LG-Ni1000	1101-6061-0211-010	<b>61,47 €</b>
RPTF1 LM235Z PVC 1,5M	LM235Z (TCR = 10 mV / K; 2.73 V at 0 °C), KP10	1101-6062-1211-110	<b>56,03 €</b>
RPTF1 NTC1,8K PVC 1,5M	NTC 1.8K	1101-6061-2211-010	<b>61,24 €</b>
RPTF1 NTC10K PVC 1,5M	NTC 10K	1101-6061-5211-010	<b>61,24 €</b>
RPTF1 NTC20K PVC 1,5M	NTC 20K	1101-6061-6211-010	<b>61,24 €</b>

**ACCESSORIES**

<b>SF-M</b>	<b>Metal</b> sinter filter, Ø 16 mm, L = 32 mm, exchangeable stainless steel <b>V4A</b> (1.4404)	7000-0050-2200-100	<b>40,31 €</b>
Extra charge:	2-wire connecting leads, per running meter (PVC) 4-wire connecting leads, per running meter (PVC)		on request on request
For special orders please specify:	Type, sensor type and cable length e.g. RPTF1 Pt100, 3m; RPTF1 Pt1000, 4m; RPTF1 KTY 81-210, 6m		



Resistance thermometer **THERMASGARD® RPTF 2** with passive output is specifically used for temperature detection in larger rooms and halls, as dark radiation sensor for example. The pendulum room sensor RPTF-2 (globe thermometer) determines the effective portion of active radiation or also the effective radiant heat at the measured location. Due to the measuring method employed by this pendulum room temperature sensor in combination with its positioning in the room, an excellent and room-representative measuring result is achieved. The globe temperature is determined to take heat radiation into consideration and to estimate the degree of thermal comfort (operative room temperature). The operative room temperature describes the coaction of heat radiation and heat convection (the ratio of globe temperature / air temperature is approx. 70% / 30%).

TECHNICAL DATA	
Measuring range:	-5...+60 °C
Sensors / output:	see table, passive (optional also with two sensors)
Connection type:	2-wire connection (4-wire connection optional)
Testing current:	< 0.6 mA (Pt1000) < 1.0 mA (Pt100) < 0.3 mA (Ni1000, Ni1000 TK5000) < 2.0 mW (NTC xx) 400 µA...5 mA (LM235Z)
Globe:	plastic, colour black, Ø = 50 mm
Connection cable:	PVC, H03VV-F, 2 x 0.5 mm <sup>2</sup> , ends stripped with wire end sleeves KL = approx. 1.5 m (other lengths optional)
Insulating resistance:	≥ 100 MΩ, at +20 °C (500 V DC)
Humidity:	< 95% r. H.
Protection class:	III (according to EN 60 730)
Protection type:	<b>IP 65</b> (according to EN 60 529)



RPTF 2

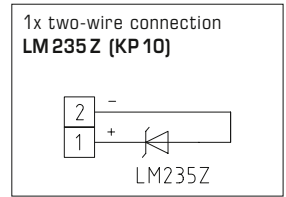
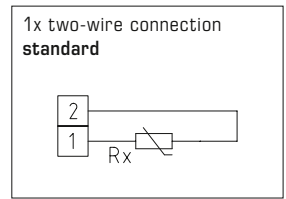
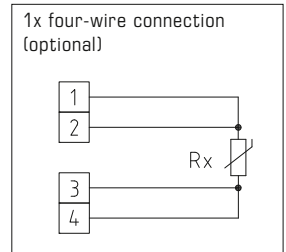
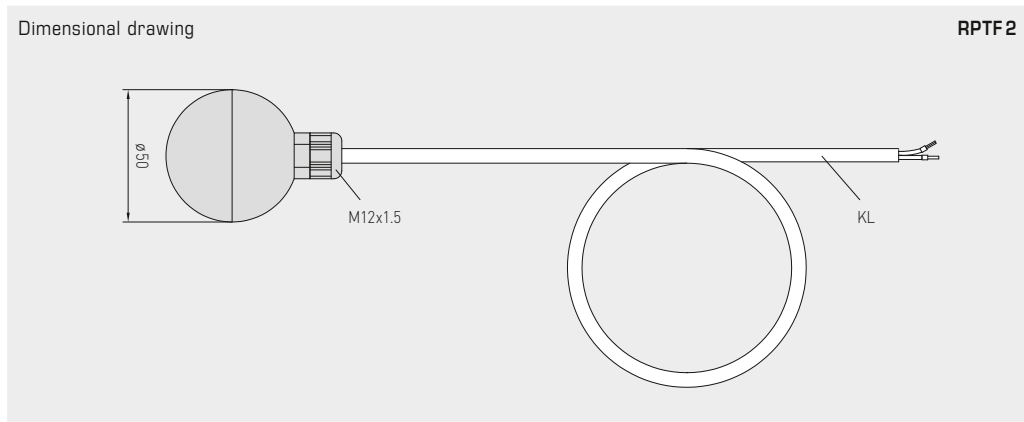

**THERMASGARD® RPTF 2** Pendulum room temperature sensors (with globe)

Type / WG03	Sensor / Output	Item No.	Price
<b>RPTF 2</b>		<b>IP 65</b>	
RPTF2 Pt100 PVC 1,5M	Pt100 (according to DIN EN 60 751, class B)	1101-6070-1211-010	<b>56,03 €</b>
RPTF2 Pt1000 PVC 1,5M	Pt1000 (according to DIN EN 60 751, class B)	1101-6070-5211-010	<b>58,92 €</b>
RPTF2 Ni1000 PVC 1,5M	Ni1000 (according to DIN EN 43 760, class B, TCR = 6180 ppm / K)	1101-6070-9211-010	<b>57,94 €</b>
RPTF2 NiTK PVC 1,5M	Ni1000 TK5000 (TCR = 5000 ppm / K), LG - Ni1000	1101-6071-0211-010	<b>61,58 €</b>
RPTF2 LM235Z PVC 1,5M	LM235Z (TCR = 10 mV / K; 2.73V at 0 °C), KP10	1101-6072-1211-010	<b>56,14 €</b>
RPTF2 NTC1,8K PVC 1,5M	NTC 1.8K	1101-6071-2211-010	<b>61,35 €</b>
RPTF2 NTC10K PVC 1,5M	NTC 10K	1101-6071-5211-010	<b>61,35 €</b>
RPTF2 NTC20K PVC 1,5M	NTC 20K	1101-6071-6211-010	<b>61,35 €</b>
Extra charge::	2-wire connecting leads, per running meter (PVC) 4-wire connecting leads, per running meter (PVC)		on request on request
For special orders please specify:	Type, sensor type and cable length e. g. RPTF2 Pt100, 3m; RPTF2 Pt1000, 4m; RPTF2 KTY 81-210, 6m		



**On-wall radiation temperature sensors with passive output**

ASTF

Resistance thermometer **THERMASGARD® ASTF** with passive output, terminal box housing made of impact-resistant plastic and housing cover with quick-locking screws. This radiation sensor is specifically designed for temperature detection in wet areas or in larger rooms or halls. The on-wall radiation temperature sensor ASTF determines the effective portion of active radiation or the effective radiant heat at the measured location. Due to the measuring method employed by the dark radiation temperature sensor, excellent and room-representative measuring results are achieved.



**TECHNICAL DATA**

Measuring range:	-30 ...+ 75 °C
Sensors / output:	see table, passive (optional also with two sensors)
Connection type:	2-wire connection (4-wire connection on PT100, optional on other sensors)
Testing current:	< 0.6 mA (Pt1000) < 1.0 mA (Pt100) < 0.3 mA (Ni1000, Ni1000 TK5000) < 2.0 mW (NTC xx) 400 µA...5 mA (LM235Z)
Insulating resistance:	≥ 100 MΩ, at +20 °C (500 V DC)
Process connection:	by screws
Housing:	plastic, UV-resistant, material polyamide, 30% glass-globe reinforced, with quick-locking screws (slotted / Phillips head combination), colour traffic white (similar to RAL 9016), semi-globe: black
Housing dimensions:	72 x 64 x 37.8 (51.8) mm (Tyr 1)
Cable connection:	<b>cable gland</b> , plastic (M16 x 1.5; with strain relief, exchangeable, max. inner diameter 10.4 mm) <b>or</b> <b>M12 connector</b> according to DIN EN 61076-2-101 (optional on request)
Electrical connection:	0.14 - 1.5 mm², via terminal screws
Humidity:	< 95 % r. H.
Protection class:	III (according to EN 60 730)
Protection type:	<b>IP65</b> (according to EN 60529) Housing tested, TÜV SÜD, Report No. 713139052 (Tyr 1)

Dimensional drawing

ASTF

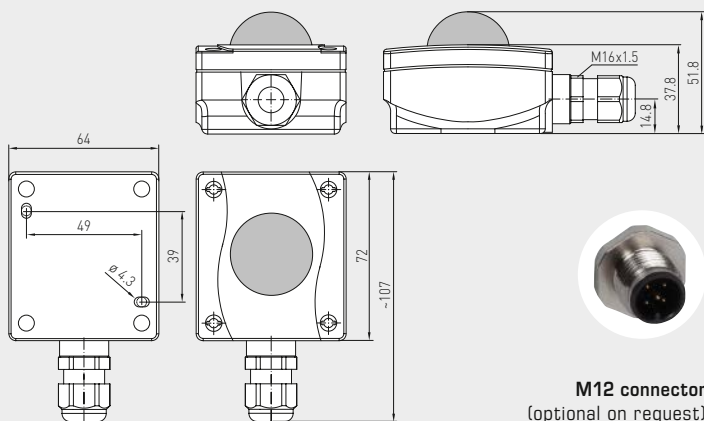

**M12 connector**  
(optional on request)

1x two-wire connection standard

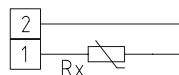

1x two-wire connection LM235Z (KP 10)

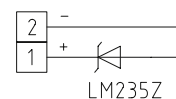

1x three-wire connection (optional)

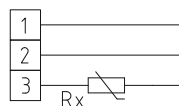

1x four-wire connection (optional)

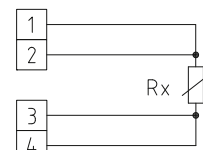

**THERMASGARD® ASTF** On-wall radiation temperature sensors

Type / WG03	Sensor / Output	Item No.	Price
<b>ASTF</b>		<b>IP 65</b>	
ASTF Pt100	Pt100 (according to DIN EN 60 751, B)	1101-1060-1003-000	<b>67,13 €</b>
ASTF Pt1000	Pt1000 (according to DIN EN 60 751, class B)	1101-1060-5001-000	<b>67,13 €</b>
ASTF Ni1000	Ni1000 (according to DIN EN 43 760, class B, TCR = 6180 ppm / K)	1101-1060-9001-000	<b>68,31 €</b>
ASTF NiTK	Ni1000 TK5000 (TCR = 5000 ppm / K), LG- Ni1000	1101-1061-0001-000	<b>70,57 €</b>
ASTF LM235Z	LM235Z (TCR = 10 mV / K; 2.73 V at 0 °C), KP10	1101-1062-1001-000	<b>65,89 €</b>
ASTF NTC1,8K	NTC 1.8K	1101-1061-2001-000	<b>70,57 €</b>
ASTF NTC10K	NTC 10K	1101-1061-5001-000	<b>70,57 €</b>
ASTF NTC20K	NTC 20K	1101-1061-6001-000	<b>70,57 €</b>
Extra charge:	two or other sensors optional cable connection with <b>M12 connector</b> according to DIN EN 61076-2-101		on request on request

Resistance thermometer **THERMASGARD® RSTF** with passive output in an elegant housing made of plastic, with snap-on lid, base with 4-hole attachment for installation on vertically or horizontally installed in-wall flush boxes, with predetermined breaking point for on-wall cable entry, specifically used for temperature detection in larger rooms. The room radiation temperature sensor RSTF determines the effective portion of active radiation or the effective radiant heat at the measured location. Due to the measuring method employed by the dark radiation temperature sensor, an excellent and room-representative measuring result is achieved. In addition there is an independent passive output available to determinate the reference temperature.



**TECHNICAL DATA**

Measuring range:	-30...+75 °C
Sensors / output:	see table, passive (optional also with two sensors)
Connection type:	2-wire connection (4-wire connection on PT100, optional on other sensors)
Testing current:	< 0.6 mA (Pt1000) < 1.0 mA (Pt100) < 0.3 mA (Ni1000, Ni1000 TK5000) < 2.0 mW (NTC xx) 400 µA...5 mA (LM235Z)
Insulating resistance:	≥ 100 MΩ, at +20 °C (500 V DC)
Process connection:	by screws
Housing:	plastic, material ABS Housing: pure white (similar to RAL 9010), Semi-globe: black
Dimensions:	85 x 85 x 27 (40) mm (Baldur 1)
Electrical connection:	0.14 - 1.5 mm <sup>2</sup> , via terminal screws
Humidity:	< 95 % r. H.
Protection class:	III (according to EN 60 730)
Protection type:	<b>IP 30</b> (according to EN 60529)

Dimensional drawing

RSTF

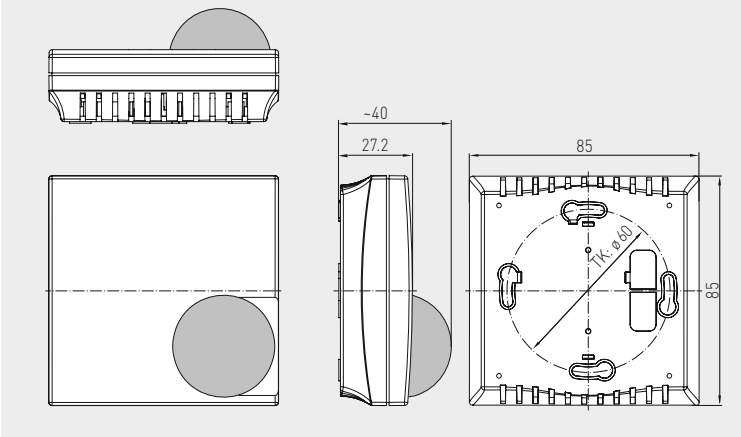

Terminals 3 and 4:  
Sensor for reference temperature

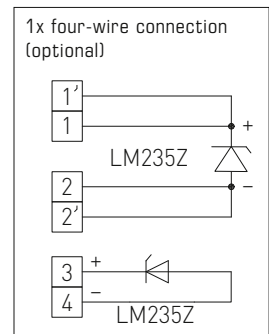
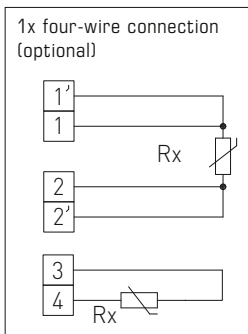
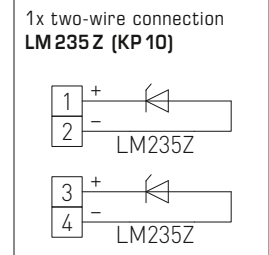
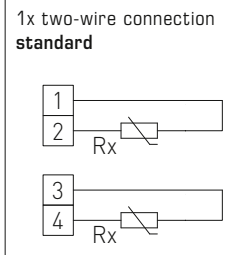

**THERMASGARD® RSTF** Room radiation temperature sensors

Type / WG03	Sensor / Output	Item No.	Price
<b>RSTF</b>		<b>IP30</b>	
RSTF Pt100	Pt100 (according to DIN EN 60 751, class B)	1101-40C0-1003-000	<b>65,89 €</b>
RSTF Pt1000	Pt1000 (according to DIN EN 60 751, class B)	1101-40C0-5001-000	<b>65,89 €</b>
RSTF Ni1000	Ni1000 (according to DIN EN 43 760, class B, TCR = 6180 ppm / K)	1101-40C0-9001-000	<b>68,31 €</b>
RSTF NiTK	Ni1000 TK5000 (TCR = 5000 ppm / K), LG-Ni1000	1101-40C1-0001-000	<b>70,24 €</b>
RSTF LM235Z	LM235Z (TCR = 10 mV / K; 2.73 V at 0 °C), KP10	1101-40C2-1001-000	<b>65,89 €</b>
RSTF NTC1,8K	NTC 1.8K	1101-40C1-2001-000	<b>69,52 €</b>
RSTF NTC10K	NTC 10K	1101-40C1-5001-000	<b>69,52 €</b>
RSTF NTC20K	NTC 20K	1101-40C1-6001-000	<b>69,52 €</b>
Extra charge:	two or other sensors optional		on request



## Temperature

### ACTIVE SENSORS

Our active **THERMASGARD®** temperature sensors are easy to install, versatile and meet all requirements important to you. Adjustable and calibratable temperature transmitters with self-diagnostics provide additional flexibility.

#### APPLICATION RANGE

- > Hospitals, museums, schools, hotels, public authorities, institutes and banks
- > Sports arenas, holiday centers and movie theaters
- > Car dealers
- > Ships and shipyards
- > Industrial plants and assembly halls
- > Power plants and refineries



## THERMASGARD®

250 – 317

### Room sensors, room control units

<b>RTM 1</b>	Room temperature measuring transducer	<b>253</b>
<b>FSTM</b>	Room temperature measuring transducer, in-wall	<b>255</b>
<b>FSTM-P</b>	Room control units, in-wall	<b>255</b>
<b>RPTM 1</b>	Pendulum room temperature measuring transducer	<b>313</b>
<b>RPTM 2</b>	Pendulum room temperature measuring transducer	<b>315</b>
<b>HSM</b>	Top hat rail measuring transducer	<b>317</b>

### Outdoor sensors, on-wall sensors

<b>ATM 2</b>	Outside temperature measuring transducer	<b>259</b>
<b>ATM 2-VA</b>	Outside temperature measuring transducer (Stainless steel housing Tyr 2E)	<b>263</b>

### Cable sensors, surface-contact sensors

<b>HFTM</b>	Sleeve sensor with cable, temperature measuring transducer	<b>297</b>
<b>HFTM-VA</b>	Sleeve sensor with cable, temperature measuring transducer (Stainless steel housing Tyr 2E)	<b>301</b>
<b>ALTM 1</b>	Surface-contact temperature measuring transducer	<b>303</b>
<b>ALTM 2</b>	Surface-contact temperature measuring transducer with cable	<b>307</b>
<b>ALTM 2-VA</b>	Surface-contact temperature measuring transducer with cable (Stainless steel housing Tyr 2E)	<b>311</b>

### Duct / immersion / screw-in sensors

<b>TM 43</b>	Duct / immersion / screw-in temperature measuring transducer	<b>267</b>
<b>TM 65</b>	Duct / immersion / screw-in temperature measuring transducer	<b>267</b>
<b>TM 54</b>	Duct / immersion / screw-in temperature measuring transducer	<b>277</b>
<b>RGTM 2</b>	Smoke gas temperature measuring transducer, screw-in sensor	<b>291</b>
<b>RGTM 1</b>	Smoke gas temperature measuring transducer, duct sensor	<b>285</b>
<b>MWTM</b>	Mean-value temperature measuring transducer, rod sensor	<b>273</b>
<b>MWTM-SD</b>	Mean-value temperature measuring transducer, rod sensor	<b>273</b>

### Immersion sleeves and accessories

see chapter Accessories	<b>636</b>
-------------------------	------------



**Room temperature measuring transducers, calibratable, with multi-range switching and active output**

Calibratable room temperature measuring transducer **THERMASGARD® RTM 1** with continuous output, with or without optional display for displaying the actual temperature in an elegant housing made of plastic, with snap-on lid, base with 4-hole attachment for installation on vertically or horizontally installed in-wall flush boxes, with predetermined breaking point for on-wall cable entry, or in housing made of stainless steel (top and bottom part are of stainless steel, the lid is screwed on), vandal-proof version e.g. for schools, military barracks, and public buildings. This room temperature transmitter / residential room temperature sensor is used to detect / display temperatures in closed dry rooms, in apartments, in offices, supermarkets and business facilities.

RTM 1



**TECHNICAL DATA**

Power supply:	24 V AC / DC (± 10%) for U variant 15...36 V DC for I variant, depending on working resistance, residual ripple stabilised ± 0.3 V
Working resistance:	$R_a \text{ (ohm)} = (U_b - 14 \text{ V}) / 0.02 \text{ A}$ for I variant
Load resistance:	$R_L > 5 \text{ kOhm}$ for U variant
Sensor:	Pt1000, DIN EN 60751, class B
Measuring ranges:	<b>multi-range switching with 8 switchable measuring ranges,</b> see table (other ranges optional) operating range $-30...+70 \text{ }^\circ\text{C}$ <b>with manual zero point correction (± 10K)</b>
Deviation, temperature:	typically ± 0.2K at +25 °C
Output:	0 - 10V or 4...20mA
Ambient temperature:	measuring transducer $-30...+70 \text{ }^\circ\text{C}$
Connection type:	2- or 3-wire connection
Process connection:	by screws
Housing:	plastic, material ABS, colour pure white (similar to RAL 9010), (optional stainless steel) <b>V2A</b> (1.4301)
Dimensions:	85 x 85 x 27 mm (Baldur 1) 75 x 75 x 25 mm (stainless steel)
Electrical connection:	0.14 - 1.5 mm <sup>2</sup> via terminal screws
Installation:	wall mounting or on in-wall flush box Ø55 mm, base with 4-hole for mounting on vertically or horizontally installed in-wall flush boxes for cable entry from the back, with predetermined breaking point for on-wall cable entry from top / bottom in case of plain on-wall installation
Humidity:	< 95% r. H., non-precipitating air
Protection class:	III (according to EN 60 730)
Protection type:	<b>IP 30</b> (according to EN 60 529)
Standards:	CE conformity, electromagnetic compatibility according to EN 61326, according to EMC directive 2014 / 30 / EU
Optional:	Two-line <b>display with illumination</b> , cutout 36 x 15 mm (W x H), for displaying the <b>ACTUAL temperature</b> and the <b>internal diagnostics</b> (sensor breakage, sensor short circuit) see beginning of this chapter!

Measuring ranges (adjustable)	DIP 1	DIP 2	DIP 3
-20 °C...+150 °C	ON	ON	ON
-50 °C... +50 °C	OFF	ON	ON
-20 °C... +80 °C	ON	OFF	ON
-30 °C... +60 °C	OFF	OFF	ON
0 °C... +40 °C	ON	ON	OFF
<b>0 °C... +50 °C*</b>	OFF	ON	OFF
0 °C...+100 °C	ON	OFF	OFF
0 °C...+150 °C	OFF	OFF	OFF

\* (default / fixed with display)

Display and internal diagnostics

**RTM 1-U-Display**  
**RTM 1-I-Display**

Standard  
Sensor breakage  
Sensor short circuit

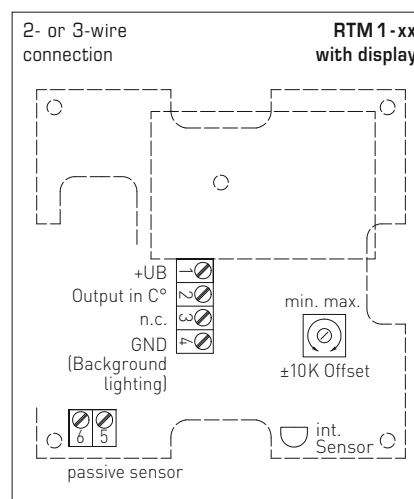
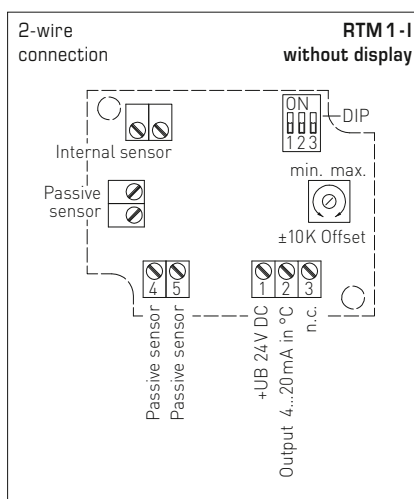
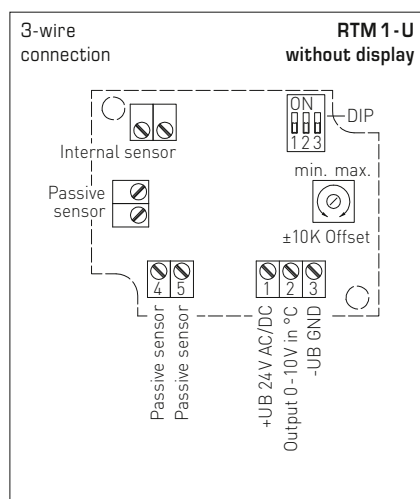





S+S REGELTECHNIK

THERMASGARD® RTM 1

Room temperature measuring transducers, calibratable, with multi-range switching and active output

Dimensional drawing

Housing Baldur 1

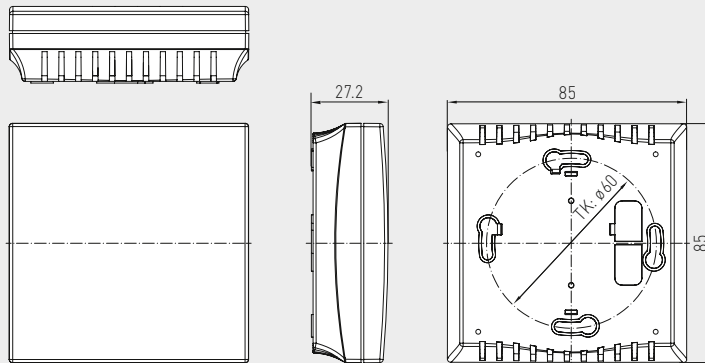

RTM 1 with display



Dimensional drawing

Housing stainless steel

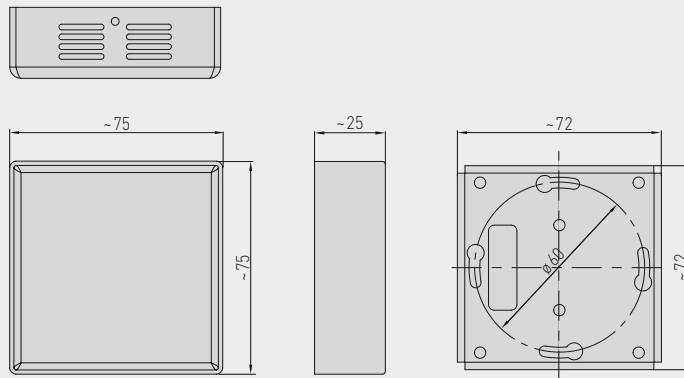

RTM 1 (stainless steel)

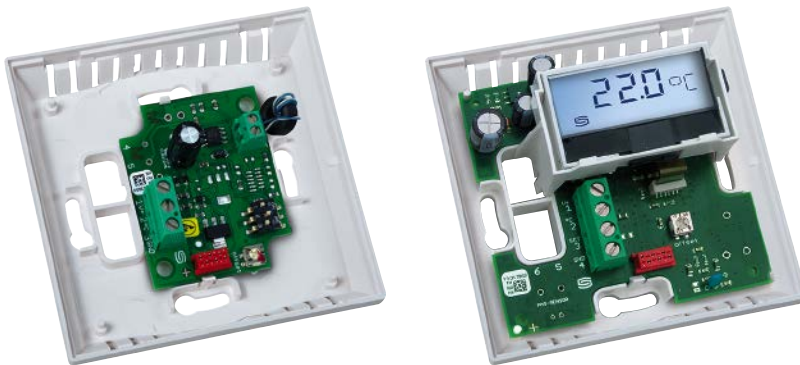

Dependency of output voltage on output current

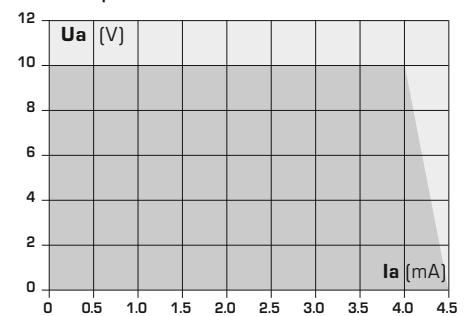

THERMASGARD® RTM 1 Room temperature measuring transducers

Type / WG01	Sensor	Output	Features	Display	Item No.	Price
<b>RTM1 - U</b>						
<b>IP 30, U-variant</b>						
RTM1-U	Pt1000	0 - 10 V	-		1101-41A1-0000-200	72,94 €
RTM1-U LCD	Pt1000	0 - 10 V	Display*	■	1101-41A1-2000-200	115,06 €
RTM1-U VA	Pt1000	0 - 10 V	Stainless steel housing V2A (1.4301)		1101-4151-0000-200	189,76 €
<b>RTM1 - I</b>						
<b>IP 30, I-variant</b>						
RTM1-I	Pt1000	4...20 mA	-		1101-41A2-0000-200	72,94 €
RTM1-I LCD	Pt1000	4...20 mA	Display*	■	1101-41A2-2000-200	115,06 €
RTM1-I VA	Pt1000	4...20 mA	Stainless steel housing V2A (1.4301)		1101-4152-0000-200	189,76 €
Extra charge:	Other ranges optional					24,19 €
Note:	* When equipped with display, the measuring range of 0...+50 °C is fixed.					

**Room temperature sensor or measuring transducer,  
in-wall in the panel switch programme,  
with active output**

The room sensor **THERMASGARD® FSTM / FSTM - P** in the in-wall housing, optionally with potentiometer, is used for measuring the room temperature, and for setpoint adjustment. It converts the measured values into a standard signal of 0-10 V. A digital, long-term stable sensor is used for temperature measurement.

The in-wall sensor is mounted in high-quality panel switch programmes, ideally of the brands Gira, Berker, Merten, Jung, Siemens or Busch-Jaeger (using in-wall adapters, no setpoint adjustment possible) either individually or in combination with light switches, socket outlets, etc.

It is used in non-aggressive, dust-free environments, in refrigeration, air conditioning and clean room technology, and in interior rooms, such as living rooms, offices, hotels, etc.

#### TECHNICAL DATA

Power supply: 24 V AC / DC (± 10 %)

Power consumption: < 1.1 W / 24 V DC; < 2.2 VA / 24 V AC

#### TEMPERATURE

Sensor: **digital temperature sensor,**  
low hysteresis, high long-term stability

Long-term stability: ± 1 % per year

Measuring range: 0...+50 °C

Deviation, temperature: typically ± 0.8 K at +25 °C

Output, temperature: 0-10 V

#### POTENTIOMETER

Output, potentiometer: 0-10 V

Mounting: in-wall flush box Ø 55 mm

Electrical connection: 1,0-2,5 mm<sup>2</sup>, via plug terminals

Ambient temperature: Storage -35...+85 °C;  
Operation 0...+50 °C

Permitted humidity: max. 90 % r.H., non-precipitating air

Medium: clean air and other non-aggressive, non-combustible gases

Protection class: III (according to EN 60 730)

Protection type: **IP 20** (according to 60 529)

Standards: CE-conformity, electromagnetic compatibility  
according to EN 61 326, EMC Directive 2014 / 30 / EU

#### SWITCH PROGRAMME

Manufacturer: GIRA System 55  
(other switch programmes, manufacturers, colours  
as well as prices available upon request)

Housing: plastic,  
the standard colour is pure glossy white (similar to RAL 9010)  
(other colours are available upon request with colour variants  
depending on the respective light switch programme)

Mounting diagram **in-wall**

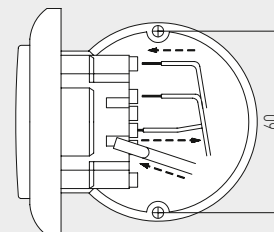

Connection diagram **FSTM**

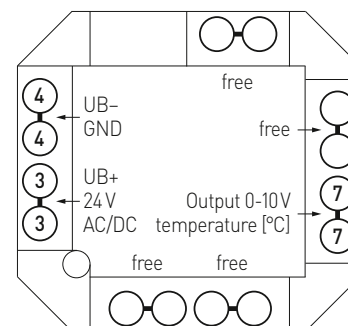

Connection diagram **FSTM - P**

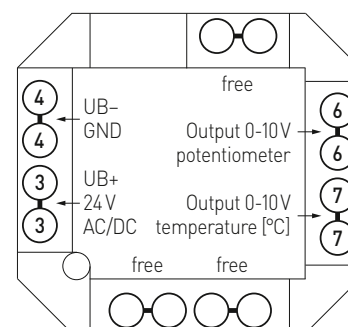



S+S REGELTECHNIK

**THERMASGARD® FSTM**  
**THERMASGARD® FSTM-P**

Room temperature sensor or measuring transducer,  
in-wall in the panel switch programme,  
with active output

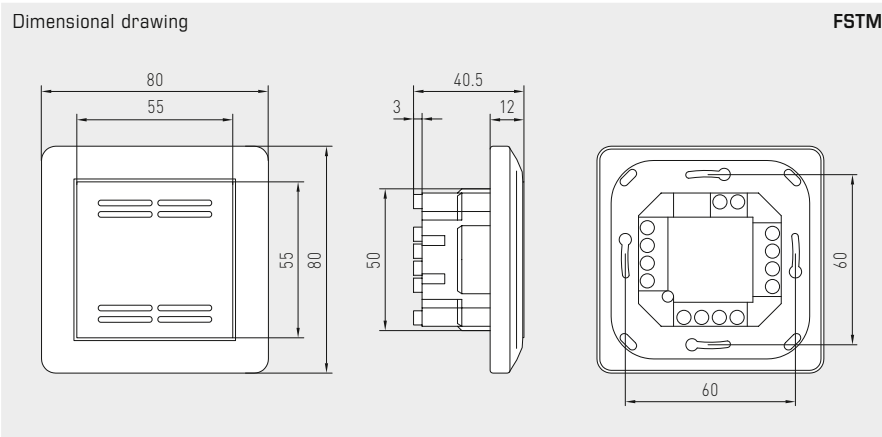

**FSTM**  
Standard

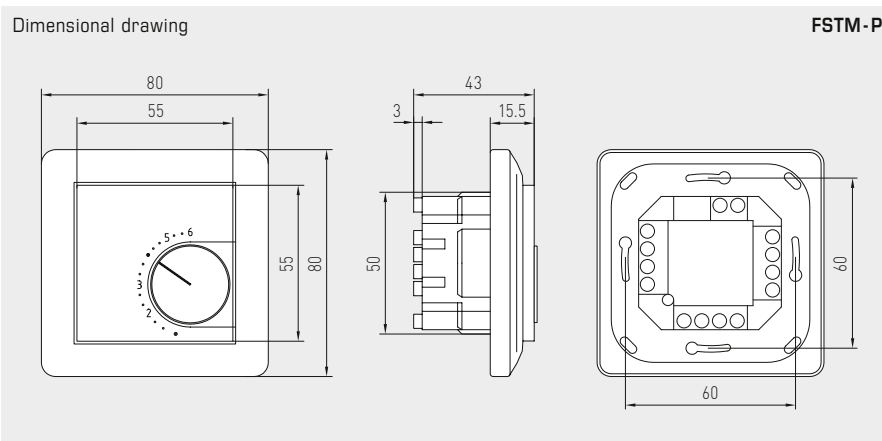

**FSTM-P**  
with potentiometer



**Temperature table**  
MR: 0...+50 °C

°C	U <sub>A</sub> [V]
0	0.0
5	1.0
10	2.0
15	3.0
20	4.0
25	5.0
30	6.0
35	7.0
40	8.0
45	9.0
50	10.0

**THERMASGARD® FSTM** Room temperature sensor or measuring transducer, in-wall  
**THERMASGARD® FSTM-P** Room temperature sensor or measuring transducer, in-wall with potentiometer

Type / WG02	Measuring Range Temperature	Output Temperature	Potentiometer	Item No.	Price
<b>FSTM</b>					
FSTM-U	0...+50 °C	0-10V	-	1101-9121-0000-162	<b>119,69 €</b>
<b>FSTM-P</b>					
FSTM-U P	0...+50 °C	0-10V	0-10V	1101-9121-0004-282	<b>142,27 €</b>

**Outside temperature / wet room temperature measuring transducers, calibratable, with multi-range switching and active output**

Calibratable outside temperature measuring transducer **THERMASGARD® ATM 2** with eight switchable measuring ranges, external sensor, continuous output, housing made from impact-resistant plastic with quick-release screws, optionally **with/without display**, with **cable gland** or **M12 connector** according to DIN EN 61076-2-101.

It is used to detect outside temperatures, temperatures in wet rooms, e.g. for installation on outside walls, in cold storage buildings and greenhouses, in the industrial sector and in agriculture. Installation in outdoor areas preferably at the north side of a building or in a protected place. In case of direct solar irradiation, we recommend the use of our sun and ball-impact protection hood **WS01** or **WS04** (accessories) or the device version with the installed sun protection hood **SS02** (on request).

The sensor is factory-calibrated; an environmental precision adjustment by an expert is possible.

**TECHNICAL DATA**

Power supply:	24 V AC / DC (± 10%) for U variant 15...36 V DC for I variant, depending on working resistance, residual ripple stabilised ± 0.3 V
Working resistance:	$R_a$ (ohm) = $(U_b - 14 V) / 0.02 A$ for I variant, see load resistance diagram
Load resistance:	$R_L > 5 k\Omega$ for U variant
Power consumption:	< 1.0 VA / 24 V DC; < 2.2 VA / 24 V AC
Sensor:	Pt1000, DIN EN 60751, class B, <b>(Perfect Sensor Protection)</b> Sensor external
Measuring ranges:	<b>multi-range switching</b> <b>with 8 switchable measuring ranges</b> see table (other measuring ranges optional) operating range -30...+70 °C <b>with manual zero point correction (± 10K)</b>
Deviation in temperature:	typically ± 0.2 K at +25 °C
Output:	0 - 10 V or 4...20 mA
Connection type:	2- or 3-wire connection
Electrical connection:	0.14 - 1.5 mm <sup>2</sup> , via screw terminals
Cable connection:	<b>cable gland, stainless steel V2A</b> (1.4305) (M20 x 1.5; with strain relief, exchangeable, inner diameter 6 - 12 mm) <b>or</b> <b>M12 connector</b> (male, 5-pin, A-code) according to DIN EN 61076-2-101
Housing:	plastic, UV-resistant, material polyamide, 30% glass-globe reinforced, with quick-release screws (slotted / Phillips head combination), colour traffic white (similar to RAL 9016), cover for display is transparent!
Housing dimensions:	72 x 64 x 37.8 mm (Tyr 1 without display) 72 x 64 x 43.3 mm (Tyr 1 with display)
Protective tube:	made from stainless steel <b>V4A</b> (1.4571), Ø 6 mm, NL = 65 mm
Process connection:	by means of screws (on the housing base)
Ambient temperature:	measuring transducer -30...+70 °C
Permissible humidity:	< 95 % r.H., non-precipitating air
Protection class:	III (according to EN 60 730)
Protection type:	<b>IP 65</b> (according to EN 60 529) Housing tested, TÜV SÜD, Report No.713139052 (Tyr 1)
Standards:	CE conformity, electromagnetic compatibility according to EN 61326, according to EMC Directive 2014 / 30 / EU
Optional:	<b>display with illumination</b> , two-line, cut-out approx. 36 x 15 mm (B x H), to display the <b>actual temperature</b> and <b>internal diagnostics</b> (measuring range exceeded, measuring range not reached, sensor breakage, sensor short circuit)

**ACCESSORIES** (see table)

**ATM 2**  
with cable gland  
and SS-02



**ATM 2 - Q**  
with M12 connector





Outside temperature / wet room temperature measuring transducers, calibratable, with multi-range switching and active output



Dimensional drawing

ATM 2

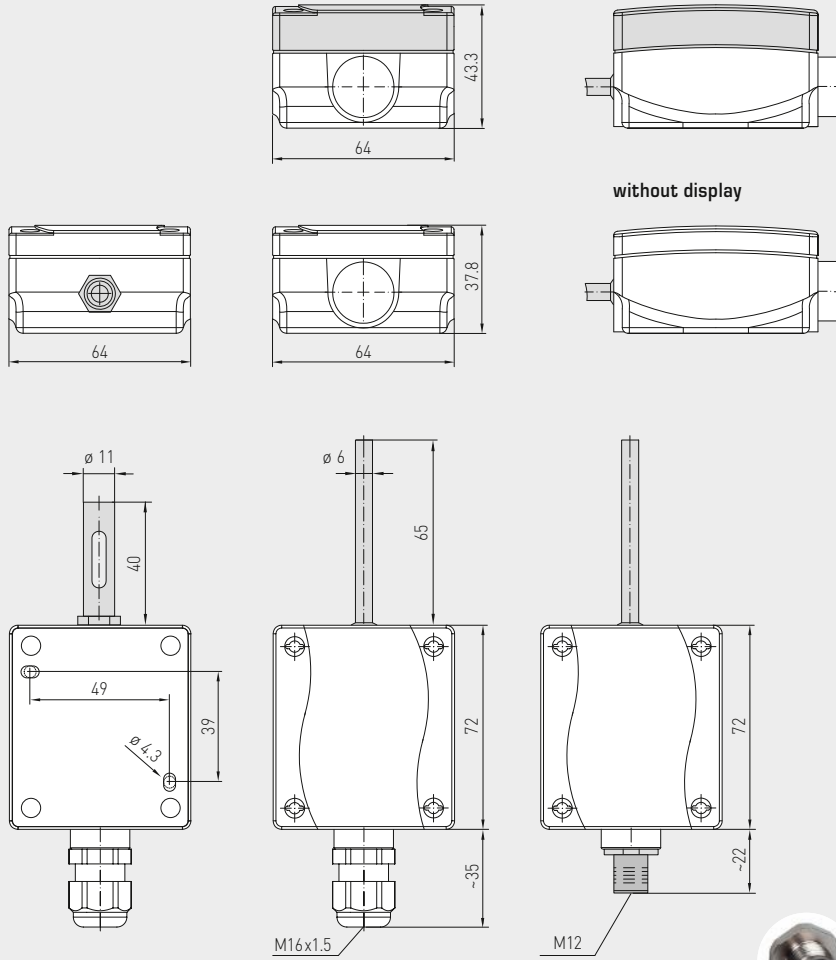

Housing with SS-02 (on request)

Housing with cable gland

Housing with M12 connector

ATM 2 with cable gland and display



ATM 2-Q with M12 connector and display



Display and internal diagnostics

THERMASGARD® Measuring transducer with display



Standard



Measuring range exceeded



Measuring range not reached



Sensor breakage



Sensor short circuit

High-performance encapsulation against vibration, mechanical stress and humidity

**PS-PROTECTION**  
PERFECT SENSOR PROTECTION



Outside temperature / wet room temperature measuring transducers, calibratable, with multi-range switching and active output

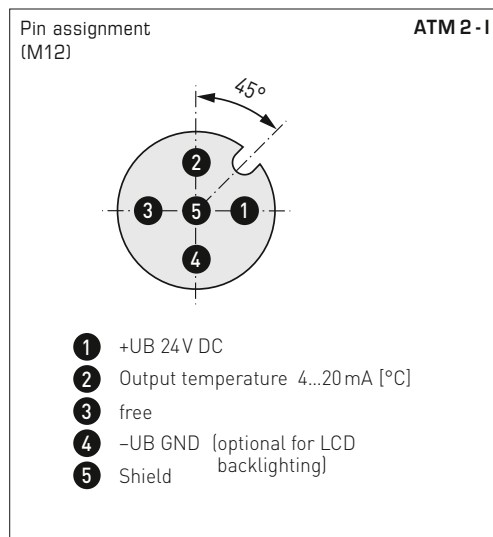
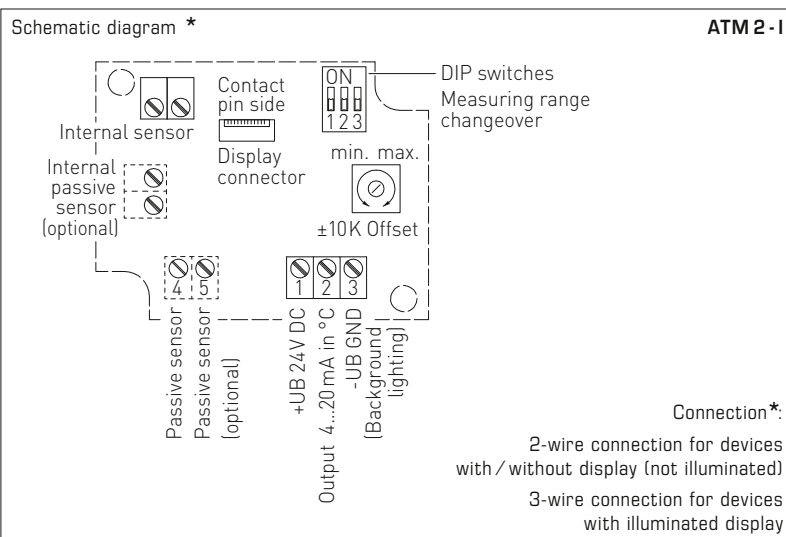
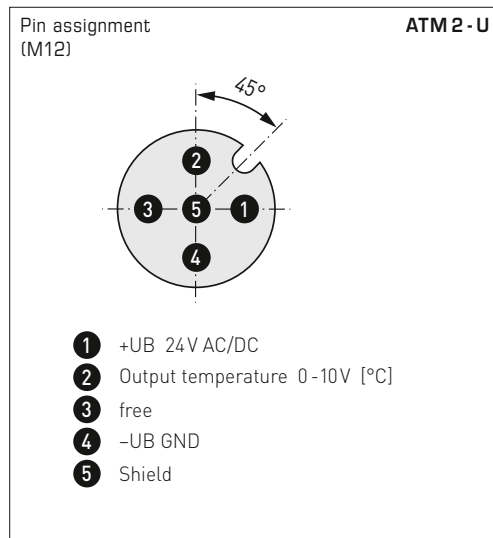
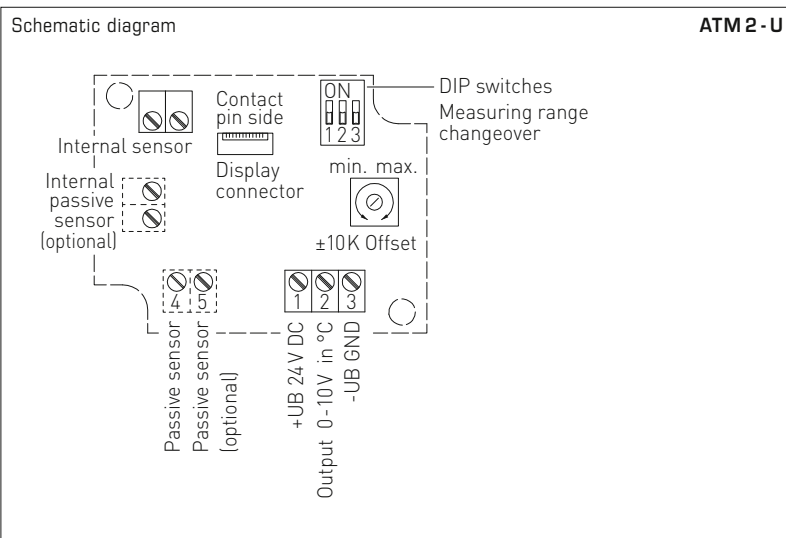

Measuring ranges (adjustable)	DIP 1	DIP 2	DIP 3
-20... +150 °C	ON	ON	ON
-50... +50 °C	OFF	ON	ON
-20... +80 °C	ON	OFF	ON
-30... +60 °C	OFF	OFF	ON
0... +40 °C	ON	ON	OFF
0... +50 °C (default)	OFF	ON	OFF
0... +100 °C	ON	OFF	OFF
0... +150 °C	OFF	OFF	OFF

**ATM2-xx**  
with display, hinged

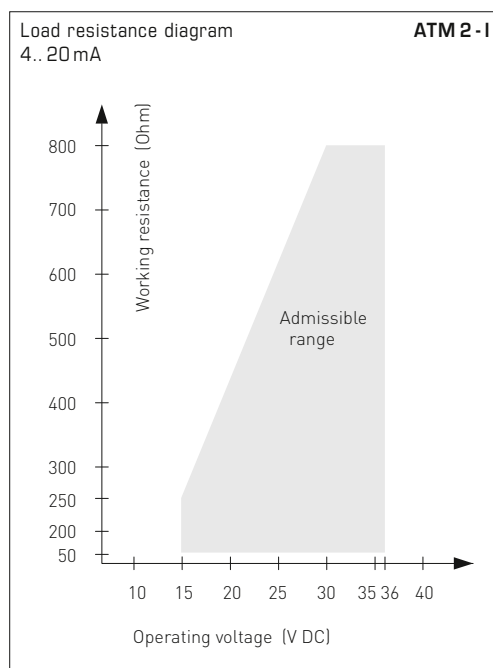
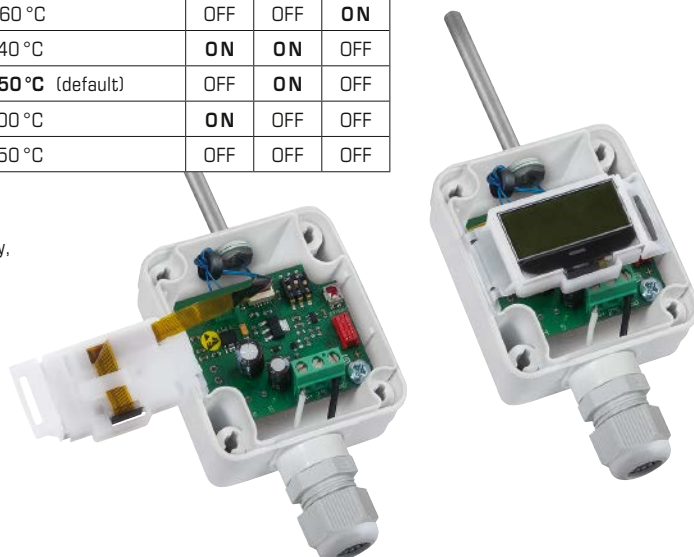



S+S REGELTECHNIK

THERMASGARD® ATM 2

Outside temperature / wet room temperature measuring transducers,  
calibratable, with multi-range switching and  
active output

ATM 2 - Q  
with M12 connector



ATM 2  
with cable gland

THERMASGARD® ATM 2		Outside temperature / wet room temperature measuring transducers (with cable gland)				
Type / WG01	Sensor	Output	Display	Item No.	Price	
<b>ATM 2</b>						
ATM2-I	Pt1000	4...20 mA		1101-1142-0009-900	95,74 €	
ATM2-I LCD	Pt1000	4...20 mA	■	1101-1142-2009-900	144,23 €	
ATM2-U	Pt1000	0-10 V		1101-1141-0009-900	95,74 €	
ATM2-U LCD	Pt1000	0-10 V	■	1101-1141-2009-900	144,23 €	
<b>Housing variant:</b>		Cable connection with cable gland				
Extra charge:		other measuring ranges optional with sun protection hood SS02			24,19 € on request	

THERMASGARD® ATM 2-Q		Outside temperature / wet room temperature measuring transducers (with M12 connector)				
Type / WG01	Sensor	Output	Display ● = Q	Item No.	Price	
<b>ATM 2 - Q</b>						
ATM2-I Q	Pt1000	4...20 mA	●	2001-6111-2100-001	135,66 €	
ATM2-I Q LCD	Pt1000	4...20 mA	● ■	2001-6112-2100-001	184,16 €	
ATM2-U Q	Pt1000	0-10 V	●	2001-6111-1100-001	135,66 €	
ATM2-U Q LCD	Pt1000	0-10 V	● ■	2001-6112-1100-001	184,16 €	
<b>Housing variant "Q":</b>		Cable connection with M12 connector (male, 5-pin, A-code)				
Extra charge:		see table above!				

ACCESSORIES					
WS-01	protection contre le soleil et pare-balle, 184 x 180 x 80 mm, en acier inox V2A (1.4301)			7100-0040-2000-000	30,26 €
WS-04	protection contre le soleil et les intempéries, 130 x 180 x 135 mm, en acier inox V2A (1.4301)			7100-0040-7000-000	35,70 €
<b>Special accessories for M12 connector</b> see chapter Accessories!					

**Outside temperature / wet room temperature measuring transducers,  
calibratable, with multi-range switching and  
active output**

Calibratable outside temperature measuring transducer **THERMASGARD® ATM 2 - VA** with eight switchable measuring ranges, external sensor, continuous output, rugged housing made from **stainless steel V4A**, with **cable gland** or **M12 connector** according to DIN EN 61076-2-101.

It is used to detect outside temperatures, temperatures in wet rooms, e.g. for installation on outside walls, in cold storage buildings and greenhouses, in the industrial sector and in agriculture. Installation in outdoor areas preferably at the north side of a building or in a protected place. In case of direct solar irradiation, we recommend using our sun and ball-impact protection hood **WS01** or **WS03** (accessories).

The sensor is factory-calibrated; an environmental precision adjustment by an expert is possible.

### TECHNICAL DATA

Power supply:	24 V AC / DC ( $\pm 10\%$ ) for U variant 15...36 V DC for I variant, depending on working resistance, residual ripple stabilised $\pm 0.3$ V
Working resistance:	$R_a$ (ohm) = $(U_b - 14 \text{ V}) / 0.02 \text{ A}$ for I variant, see load resistance diagram
Load resistance:	$R_L > 5 \text{ k}\Omega$ for U variant
Power consumption:	$< 1.0 \text{ VA} / 24 \text{ V DC}$ ; $< 2.2 \text{ VA} / 24 \text{ V AC}$
Sensor:	Pt1000, DIN EN 60751, class B, <b>(Perfect Sensor Protection)</b> Sensor external
Measuring ranges:	<b>multi-range switching</b> <b>with 8 switchable measuring ranges</b> see table (other measuring ranges optional) operating range $-30 \dots +70 \text{ }^\circ\text{C}$ <b>with manual zero point correction (<math>\pm 10 \text{ K}</math>)</b>
Deviation in temperature:	typically $\pm 0.2 \text{ K}$ at $+25 \text{ }^\circ\text{C}$
Output:	0 - 10 V or 4...20 mA
Connection type:	2-wire connection
Electrical connection:	0.14 - 1.5 mm <sup>2</sup> , via screw terminals
Cable connection:	<b>cable gland, stainless steel V2A</b> (1.4305) (M20 x 1.5; with strain relief, exchangeable, inner diameter 6 - 12 mm) <b>or</b> <b>M12 connector</b> (male, 5-pin, A-code) according to DIN EN 61076-2-101
Housing:	<b>stainless steel V4A</b> (1.4571), with non-distortion cover bolting, impact resistant, high EMI shielding, corrosion, temperature, weather- and UV-resistant
Housing dimensions:	143 x 97 x 61 mm (Tyr 2E)
Protective tube:	made from stainless steel <b>V4A</b> (1.4571), $\varnothing 6 \text{ mm}$ , NL = 65 mm
Process connection:	by screws
Ambient temperature:	measuring transducer $-30 \dots +70 \text{ }^\circ\text{C}$
Permissible humidity:	$< 95\%$ r.H., non-precipitating air
Protection class:	III (according to EN 60730)
Protection type:	<b>IP 65</b> (according to EN 60529) Housing tested, TÜV SÜD, Report No. 713160960B (Skadi2)
Standards:	CE conformity, electromagnetic compatibility according to EN 61326, according to EMC Directive 2014 / 30 / EU
<b>ACCESSORIES</b>	(see table)



Dimensional drawing

ATM 2 - VA

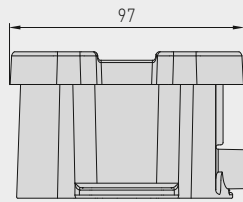
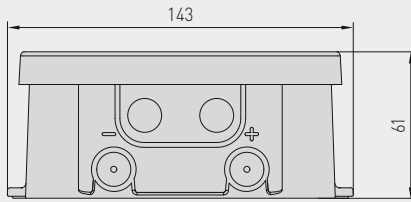

Housing with cable gland

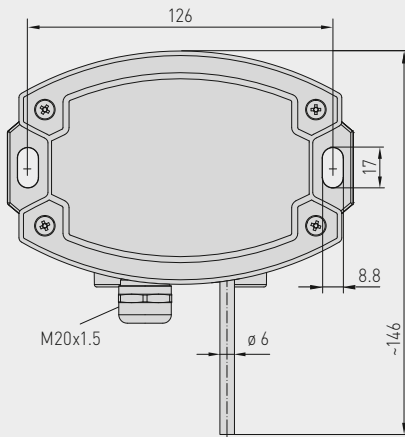

Housing with M12 connector

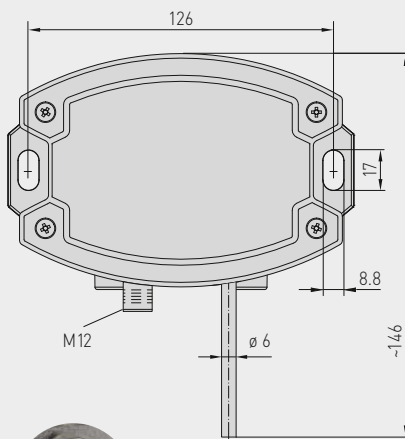

M12 connector (male)

High-performance encapsulation against vibration, mechanical stress and humidity



ATM 2 - VA with cable gland



ATM 2 - VAQ with M12 connector



Outside temperature / wet room temperature measuring transducers, calibratable, with multi-range switching and active output

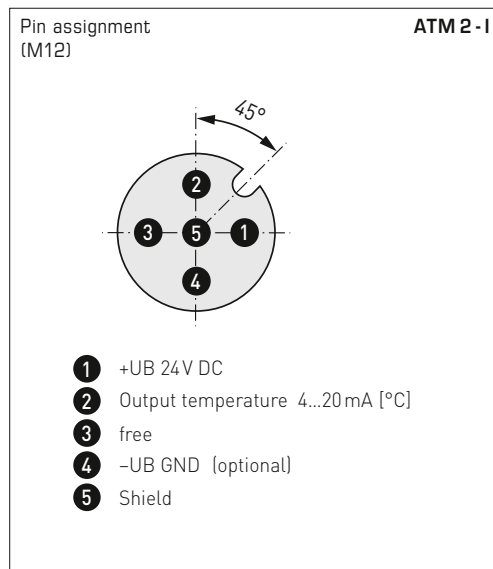
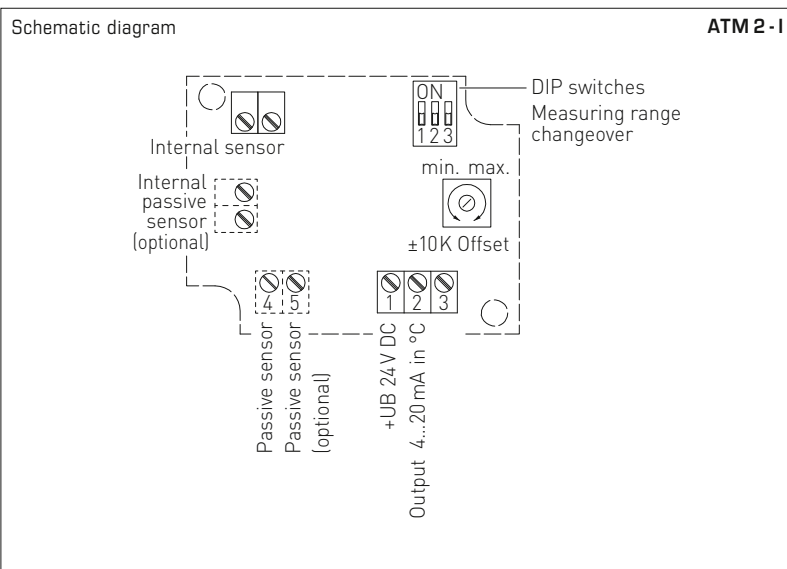
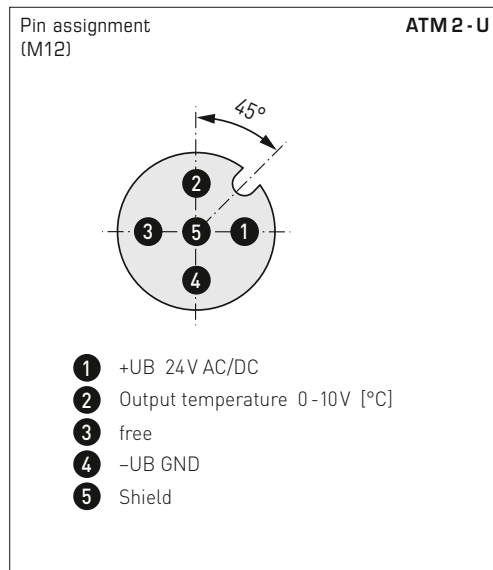
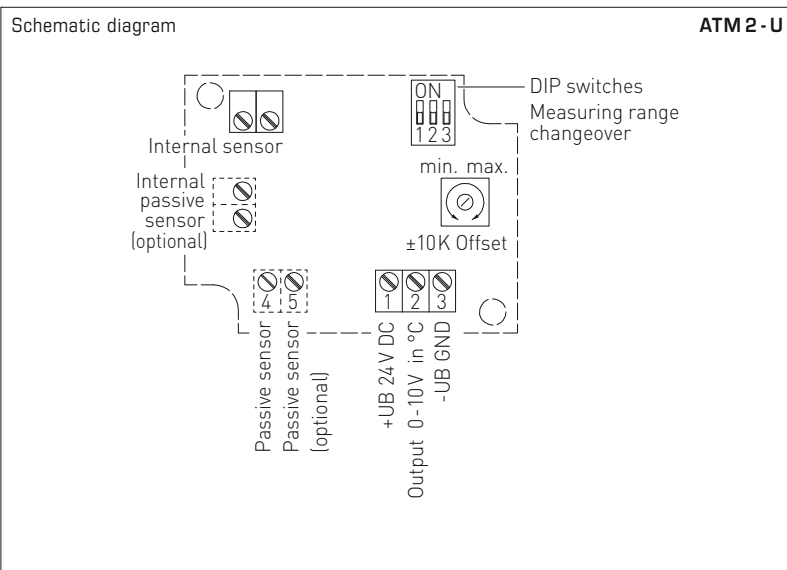

Measuring ranges (adjustable)	DIP 1	DIP 2	DIP 3
-20...+ 150 °C	ON	ON	ON
-50... + 50 °C	OFF	ON	ON
-20... + 80 °C	ON	OFF	ON
-30... + 60 °C	OFF	OFF	ON
0... + 40 °C	ON	ON	OFF
0... + 50 °C (default)	OFF	ON	OFF
0...+ 100 °C	ON	OFF	OFF
0...+ 150 °C	OFF	OFF	OFF

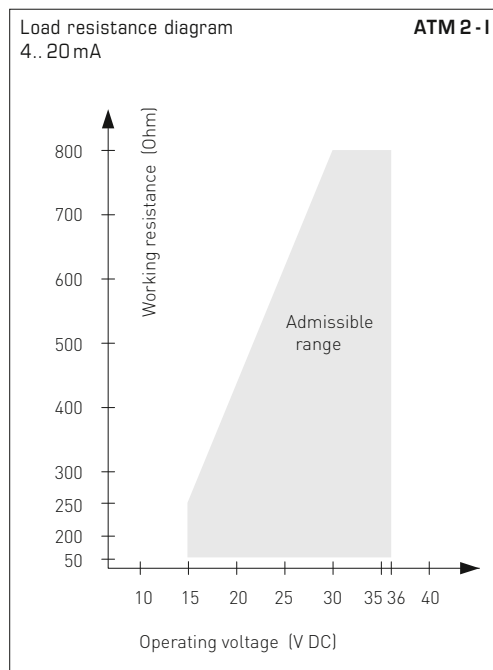





Outside temperature / wet room temperature measuring transducers, calibratable, with multi-range switching and active output

ATM 2 - VAQ  
with M12 connector



ATM 2 - VA  
with cable gland



THERMASGARD® ATM 2 - VA		Outside temperature / wet room temperature measuring transducers, <i>ID</i> (Stainless steel housing with cable gland)		
Type / WG02I	Sensor	Output	Item No.	Price
<b>ATM 2 - VA</b>				
ATM2-I VA	Pt1000	4...20 mA	2001-6171-2200-001	<b>359,38 €</b>
ATM2-U VA	Pt1000	0-10 V	2001-6171-1200-001	<b>359,38 €</b>
<b>Housing variant:</b>	Cable connection with cable gland			
Extra charge:	other measuring ranges optional			<b>24,19 €</b>

THERMASGARD® ATM 2 - VAQ		Outside temperature / wet room temperature measuring transducers, <i>ID</i> (Stainless steel housing with M12 connector)		
Type / WG02I	Sensor	Output	● = Q Item No.	Price
<b>ATM 2 - VAQ</b>				
ATM2-I VAQ	Pt1000	4...20 mA	● 2001-6171-2100-001	<b>396,08 €</b>
ATM2-U VAQ	Pt1000	0-10 V	● 2001-6171-1100-001	<b>396,08 €</b>
<b>Housing variant "Q":</b>	Cable connection with M12 connector (male, 5-pin, A-code)			
Extra charge:	see table above!			

ACCESSORIES	
Special accessories for M12 connector see chapter Accessories!	



Immersion / screw-in / duct temperature measuring transducer,  
calibratable, with multi-range switching  
and active output

**Patented quality product (Immersion sensor patent no. DE 10 2012 017 500.0)**

Calibratable temperature measuring transducer **THERMASGARD® TM 43** with eight switchable measuring ranges, continuous linear output, straight protective tube, housing made from impact-resistant plastic with snap-on lid.

Calibratable temperature measuring transducer **THERMASGARD® TM 65** with eight switchable measuring ranges, continuous linear output, straight protective tube, housing made from impact-resistant plastic with quick-locking screws, **with/without optional display**.

For the detection of temperatures in liquid or gaseous media. For aggressive media, stainless steel immersion sleeves must be used. It is used e.g. in piping systems, in heating technology, in storage tanks, in district heating compact stations, in hot-water and cold-water systems, in oil and lubricant circulation systems, in mechanical, apparatus and plant engineering as well as in the entire industrial sector. The sensor is factory-calibrated; an environmental precision adjustment by an expert is possible.

**TM 43**  
with snap-on lid  
(IP 54)



**TECHNICAL DATA**

Power supply:	24 V AC / DC (± 10 %) for U variant 15...36 V DC for I variant, depending on working resistance, residual ripple stabilised ± 0.3 V
Working resistance:	$R_a \text{ (ohm)} = (U_b - 14 \text{ V}) / 0.02 \text{ A}$ for I variant
Load resistance:	$R_L > 5 \text{ kOhm}$ for U variant
Power consumption:	< 1.0 VA / 24 V DC; < 2.2 VA / 24 V AC
Sensor:	Pt1000, DIN EN 60751, class B ( <b>Perfect Sensor Protection</b> )
Measuring ranges:	<b>multi-range switching with 8 switchable measuring ranges,</b> see table (other ranges optional) <b>with manual zero point correction (± 10 K)</b>
Deviation, temperature:	typically ± 0.2 K at +25 °C
Output:	0 - 10 V or 4...20 mA
Ambient temperature:	measuring transducer -30...+70 °C
Connection type:	2- or 3-wire connection
Housing:	plastic, UV-resistant, material polyamide, 30% glass-globe reinforced, colour traffic white (similar to RAL 9016), <b>TM 43 with snap-on lid</b> <b>TM 65 with quick-locking screws</b> (slotted / Phillips head combination), housing cover for display is transparent!
Housing dimensions:	72 x 64 x 37.8 mm (Tyr 1 / Tyr 01 without display) 72 x 64 x 43.3 mm (Tyr 1 with display)
Cable connection:	<b>cable gland</b> , plastic (M 16 x 1.5; with strain relief, exchangeable, max. inner diameter 10.4 mm) <b>or</b> <b>M12 connector</b> according to DIN EN 61076-2-101 (optional on request)
Electrical connection:	0.14 - 1.5 mm <sup>2</sup> via terminal screws on circuit board
Protective tube:	stainless steel, <b>V4A</b> (1.4571), Ø = 6 mm, inserted length (EL) = 50 - 400 mm (see table)
Humidity:	< 95 % r. H., non-precipitating air
Protection class:	III (according to EN 60730)
Protection type:	<b>TM 43 IP54</b> (according to EN 60529)* Housing tested, TÜV SÜD, Report No. 713160960A (Tyr 01) <b>TM 65 IP65</b> (according to EN 60529)* Housing tested, TÜV SÜD, Report No. 713139052 (Tyr 1) * Housing in the built-in state
Standards:	CE conformity, electromagnetic compatibility according to EN 61326, according to EMC directive 2014 / 30 / EU
Optional:	two-line <b>display with illumination</b> , cutout approx. 36 x 15 mm (W x H), for displaying the <b>ACTUAL temperature</b> and the <b>internal diagnostics</b> (measuring range exceeded, measuring range not reached, sensor breakage, sensor short circuit)

**ACCESSORIES**

<b>MF-15-K</b>	<b>Mounting flange</b> , plastic, 56.8 x 84.3 mm, Ø = 15.2 mm tube gland, T <sub>max</sub> = +100 °C
<b>TH08-ms/xx</b>	<b>Immersion sleeve, brass, nickel-plated</b> , Ø = 8 mm, T <sub>max</sub> = +150 °C, p <sub>max</sub> = 10 bar
<b>TH08-VA/xx</b>	<b>Immersion sleeve, stainless steel, V4A</b> (1.4571), Ø = 8 mm, T <sub>max</sub> = +600 °C, p <sub>max</sub> = 40 bar
<b>TH08-VA/xx/90</b>	<b>Immersion sleeve, stainless steel, V4A</b> (1.4571), with neck tube (90 mm), Ø = 8 mm, T <sub>max</sub> = +600 °C, p <sub>max</sub> = 40 bar

High-performance encapsulation against  
vibration, mechanical stress and humidity



Display and internal diagnostics  
**THERMASGARD®**  
**Measuring transducer with display**

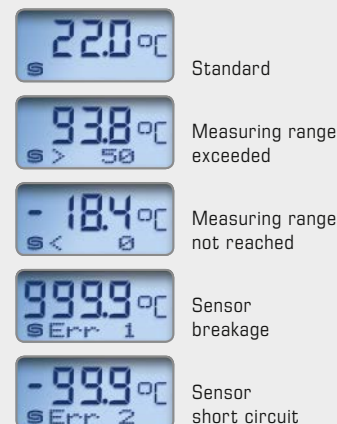

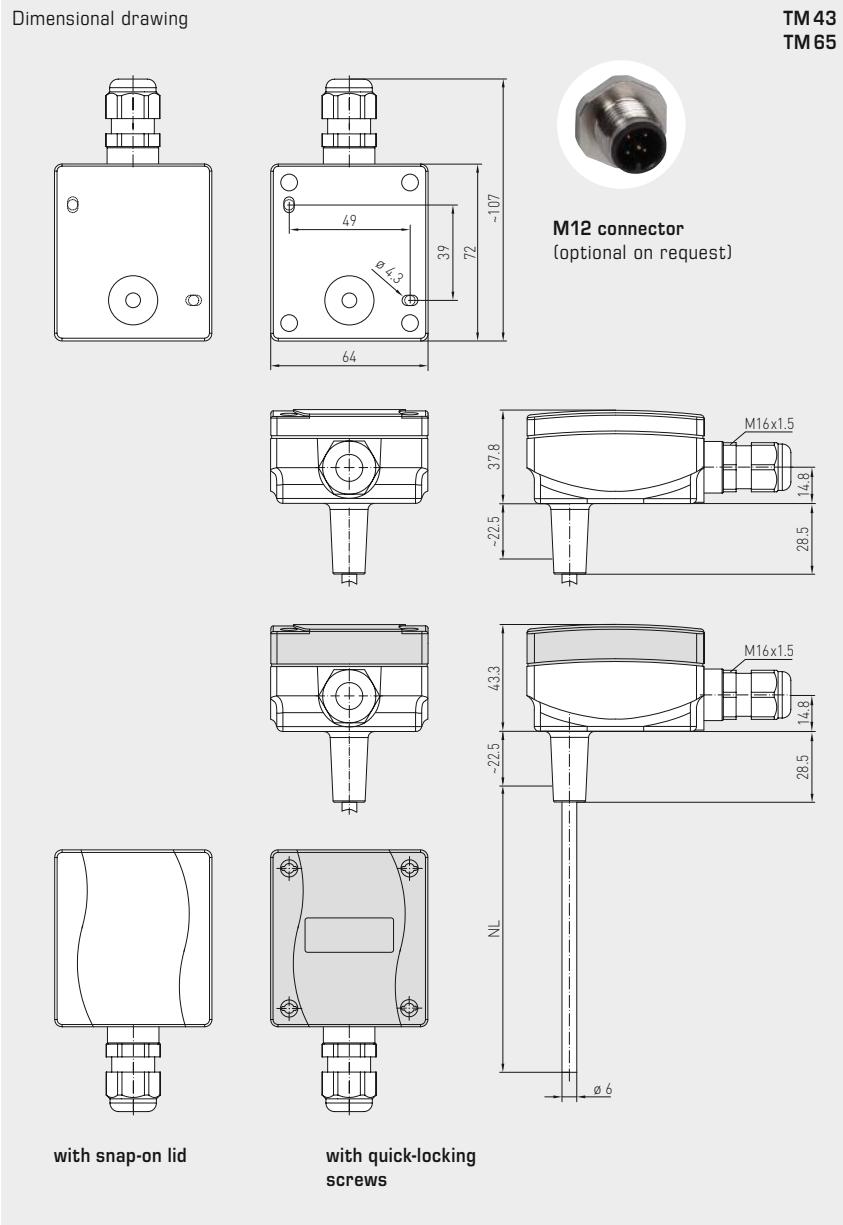
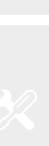

Immersion / screw-in / duct temperature measuring transducer,  
calibratable, with multi-range switching  
and active output

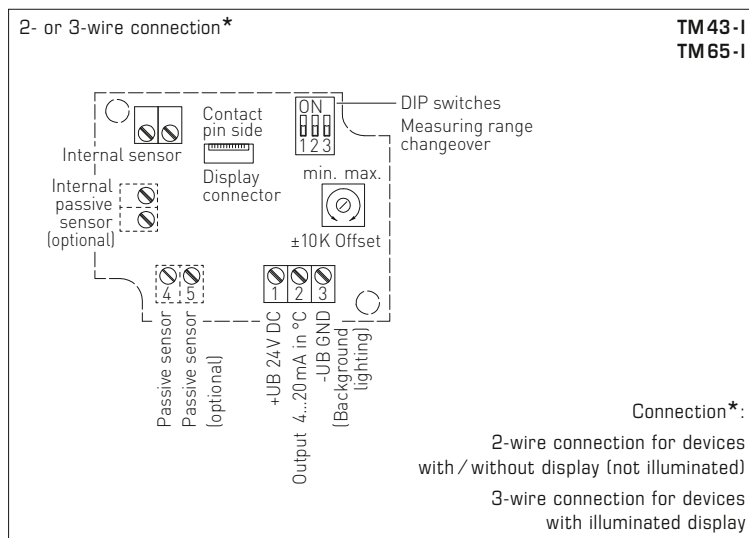
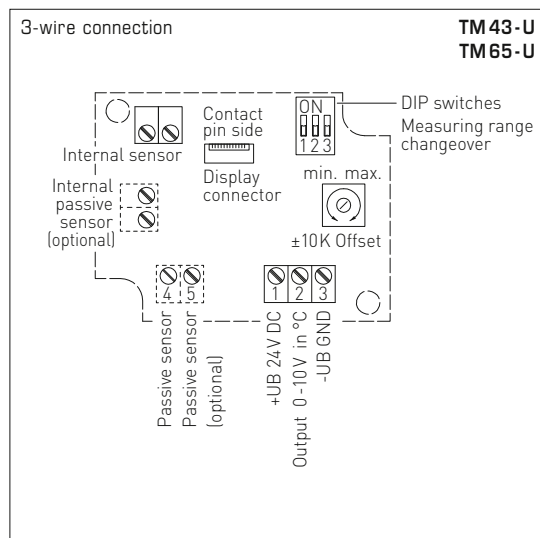

Measuring ranges (adjustable)	DIP 1	DIP 2	DIP 3
-20... +150 °C	ON	ON	ON
-50... +50 °C	OFF	ON	ON
-20... +80 °C	ON	OFF	ON
-30... +60 °C	OFF	OFF	ON
0... +40 °C	ON	ON	OFF
0... +50 °C (default)	OFF	ON	OFF
0... +100 °C	ON	OFF	OFF
0... +150 °C	OFF	OFF	OFF

Dependency of output voltage on output current

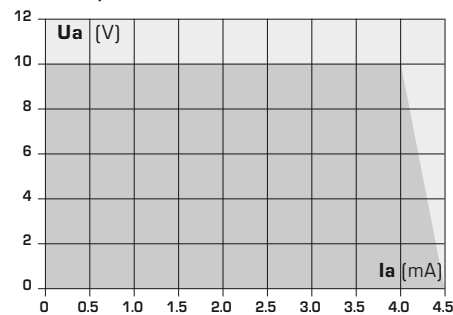

**TM 65**  
with display and  
quick-locking screws  
(IP 65)

**TM 65**  
with quick-locking screws  
(IP 65)

**TM 43**  
with snap-on lid  
(IP 54)





THERMASGARD® TM 43		Temperature measuring transducer (basic device with snap-on lid), <i>Standard</i>			
Type / WG01B	Output	Inserted Length (EL)	Item No.	Price	
<b>TM 43 - I</b>		<b>IP 54, I-variant</b>			
TM43-I 50mm	4...20 mA	50 mm	1101-7112-0019-900	68,85 €	
TM43-I 100mm	4...20 mA	100 mm	1101-7112-0029-900	69,98 €	
TM43-I 150mm	4...20 mA	150 mm	1101-7112-0039-900	71,00 €	
TM43-I 200mm	4...20 mA	200 mm	1101-7112-0049-900	71,34 €	
TM43-I 250mm	4...20 mA	250 mm	1101-7112-0059-900	72,53 €	
TM43-I 300mm	4...20 mA	300 mm	1101-7112-0069-900	73,71 €	
<b>TM 43 - U</b>		<b>IP 54, U-variant</b>			
TM43-U 50mm	0 - 10 V	50 mm	1101-7111-0019-900	68,85 €	
TM43-U 100mm	0 - 10 V	100 mm	1101-7111-0029-900	69,98 €	
TM43-U 150mm	0 - 10 V	150 mm	1101-7111-0039-900	71,00 €	
TM43-U 200mm	0 - 10 V	200 mm	1101-7111-0049-900	71,34 €	
TM43-U 250mm	0 - 10 V	250 mm	1101-7111-0059-900	72,53 €	
TM43-U 300mm	0 - 10 V	300 mm	1101-7111-0069-900	73,71 €	

THERMASGARD® TM 65		Temperature measuring transducer (basic device with quick-locking screws), <i>Premium</i>			
Type / WG01	Output	Inserted Length (EL)	Display	Item No.	Price
<b>TM 65 - I</b>		<b>IP 65, I-variant</b>			
TM65-I 50mm	4...20 mA	50 mm		1101-7122-0019-900	95,41 €
TM65-I 50mm LCD	4...20 mA	50 mm	■	1101-7122-2019-900	143,91 €
TM65-I 100mm	4...20 mA	100 mm		1101-7122-0029-900	95,68 €
TM65-I 100mm LCD	4...20 mA	100 mm	■	1101-7122-2029-900	144,16 €
TM65-I 150mm	4...20 mA	150 mm		1101-7122-0039-900	95,89 €
TM65-I 150mm LCD	4...20 mA	150 mm	■	1101-7122-2039-900	144,40 €
TM65-I 200mm	4...20 mA	200 mm		1101-7122-0049-900	96,09 €
TM65-I 200mm LCD	4...20 mA	200 mm	■	1101-7122-2049-900	144,59 €
TM65-I 250mm	4...20 mA	250 mm		1101-7122-0059-900	96,39 €
TM65-I 250mm LCD	4...20 mA	250 mm	■	1101-7122-2059-900	144,89 €
TM65-I 300mm	4...20 mA	300 mm		1101-7122-0069-900	97,11 €
TM65-I 300mm LCD	4...20 mA	300 mm	■	1101-7122-2069-900	145,59 €
TM65-I 400mm	4...20 mA	400 mm		1101-7122-0089-900	99,07 €
TM65-I 400mm LCD	4...20 mA	400 mm	■	1101-7122-2089-900	147,57 €
<b>TM 65 - U</b>		<b>IP 65, U-variant</b>			
TM65-U 50mm	0 - 10 V	50 mm		1101-7121-0019-900	95,41 €
TM65-U 50mm LCD	0 - 10 V	50 mm	■	1101-7121-2019-900	143,91 €
TM65-U 100mm	0 - 10 V	100 mm		1101-7121-0029-900	95,68 €
TM65-U 100mm LCD	0 - 10 V	100 mm	■	1101-7121-2029-900	144,16 €
TM65-U 150mm	0 - 10 V	150 mm		1101-7121-0039-900	95,89 €
TM65-U 150mm LCD	0 - 10 V	150 mm	■	1101-7121-2039-900	144,40 €
TM65-U 200mm	0 - 10 V	200 mm		1101-7121-0049-900	96,09 €
TM65-U 200mm LCD	0 - 10 V	200 mm	■	1101-7121-2049-900	144,59 €
TM65-U 250mm	0 - 10 V	250 mm		1101-7121-0059-900	96,39 €
TM65-U 250mm LCD	0 - 10 V	250 mm	■	1101-7121-2059-900	144,89 €
TM65-U 300mm	0 - 10 V	300 mm		1101-7121-0069-900	97,11 €
TM65-U 300mm LCD	0 - 10 V	300 mm	■	1101-7121-2069-900	145,59 €
TM65-U 400mm	0 - 10 V	400 mm		1101-7121-0089-900	99,07 €
TM65-U 400mm LCD	0 - 10 V	400 mm	■	1101-7121-2089-900	147,57 €
Extra charge:	Other ranges optional				24,19 €
	Cable connection with <b>M12 connector</b> according to DIN EN 61076-2-101			on request	

High-performance encapsulation against  
vibration, mechanical stress and humidity





Immersion / screw-in / duct temperature measuring transducer,  
calibratable, with multi-range switching  
and active output

One basic device in four variants...



**PATENTED**



**TMxx +  
TH08-ms/xx**

Immersion / screw-in  
temperature sensor  
with immersion sleeve,  
brass, nickel-plated

**TMxx +  
TH08-VA/xx**

Immersion / screw-in  
temperature sensor  
with immersion sleeve,  
stainless steel, V4A

**TMxx +  
TH08-VA/xx/90**

Immersion / screw-in  
temperature sensor with  
immersion sleeve with  
neck tube, stainless steel, V4A

**TMxx +  
MF-15-K**

Duct temperature sensor  
with mounting flange, plastic

Dimensional drawing  
**TH08-ms/xx**

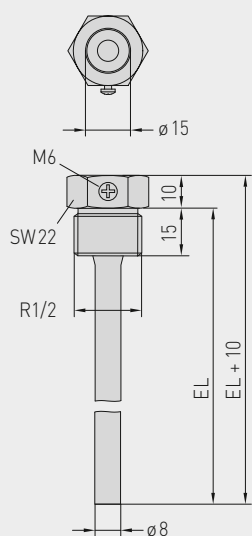

Dimensional drawing  
**TH08-VA/xx**

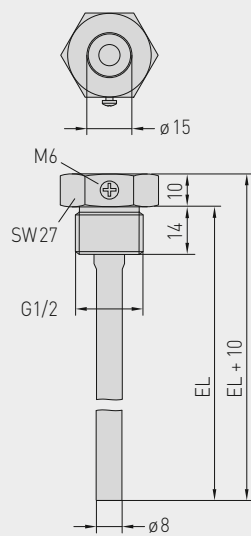

Dimensional drawing  
**TH08-VA/xx/90**

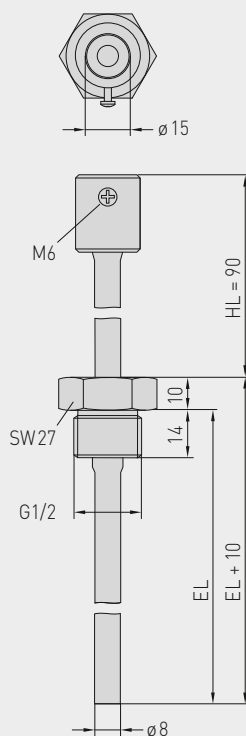

Dimensional drawing  
**MF-15-K**

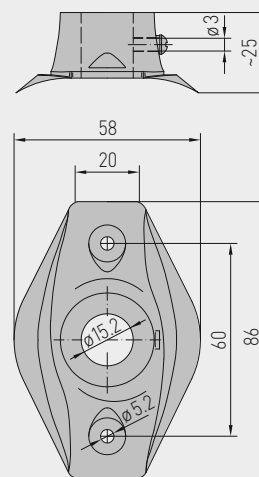



... through combination with accessories:



**TH08-ms/xx**  
Immersion sleeve,  
brass, nickel-plated,  
thread-sealing, conical,  
according to DIN 10226



**TH08-VA/xx**  
Immersion sleeve,  
stainless steel, V4A,  
flat-sealing, cylindrical,  
according to DIN 228



**TH08-VA/xx/90**  
Immersion sleeve with neck tube,  
stainless steel, V4A,  
flat-sealing, cylindrical,  
according to DIN 228



**MF-15-K**  
Mounting flange,  
plastic

THERMASGARD® TH08		Immersion sleeve Ø 8 mm (Accessories)			
Type / WG01B	p <sub>max</sub> (static)	T <sub>max</sub>	Inserted Length (EL)	Item No.	Price
<b>TH08-ms/xx</b>	<b>Brass nickel-plated</b>			without neck tube	
TH08-MS 50MM	10 bar	+150 °C	50 mm	7100-0011-0010-132	8,87 €
TH08-MS 100MM	10 bar	+150 °C	100 mm	7100-0011-0020-132	10,10 €
TH08-MS 150MM	10 bar	+150 °C	150 mm	7100-0011-0030-132	10,67 €
TH08-MS 200MM	10 bar	+150 °C	200 mm	7100-0011-0040-132	11,01 €
TH08-MS 250MM	10 bar	+150 °C	250 mm	7100-0011-0050-132	12,75 €
TH08-MS 300MM	10 bar	+150 °C	300 mm	7100-0011-0060-132	13,10 €
TH08-MS 350MM	10 bar	+150 °C	350 mm	7100-0011-0070-132	13,21 €
TH08-MS 400MM	10 bar	+150 °C	400 mm	7100-0011-0080-132	13,33 €
<b>TH08-VA/xx</b>	<b>Stainless steel, V4A (1.4571)</b>			without neck tube	
TH08-VA 50MM	40 bar	+600 °C	50 mm	7100-0012-0010-132	19,31 €
TH08-VA 100MM	40 bar	+600 °C	100 mm	7100-0012-0020-132	21,34 €
TH08-VA 150MM	40 bar	+600 °C	150 mm	7100-0012-0030-132	22,93 €
TH08-VA 200MM	40 bar	+600 °C	200 mm	7100-0012-0040-132	24,17 €
TH08-VA 250MM	40 bar	+600 °C	250 mm	7100-0012-0050-132	30,05 €
TH08-VA 300MM	40 bar	+600 °C	300 mm	7100-0012-0060-132	31,40 €
TH08-VA 350MM	40 bar	+600 °C	350 mm	7100-0012-0070-132	31,61 €
TH08-VA 400MM	40 bar	+600 °C	400 mm	7100-0012-0080-132	32,17 €
<b>TH08-VA/xx/90</b>	<b>Stainless steel, V4A (1.4571)</b>			with neck tube (90 mm)	
TH08-VA 50/90MM	40 bar	+600 °C	50 mm	7100-0012-0012-132	27,66 €
TH08-VA 100/90MM	40 bar	+600 °C	100 mm	7100-0012-0022-132	28,90 €
TH08-VA 150/90MM	40 bar	+600 °C	150 mm	7100-0012-0032-132	30,32 €
TH08-VA 200/90MM	40 bar	+600 °C	200 mm	7100-0012-0042-132	31,61 €
TH08-VA 250/90MM	40 bar	+600 °C	250 mm	7100-0012-0052-132	33,13 €
TH08-VA 300/90MM	40 bar	+600 °C	300 mm	7100-0012-0062-132	35,91 €
Note:	inner diameter of socket 15.0 mm For further information see last chapter!				
<b>Mounting flange (Accessories)</b>					
Type / WG01B		T <sub>max</sub>		Item No.	Price
<b>MF</b>					
<b>MF-15-K</b>	<b>Mounting flange, plastic,</b> 56.8x84.3mm, Ø 15.2mm tube gland	+100 °C		7100-0032-0000-000	5,83 €
Note:	For further information see last chapter!				

Mean value / rod / duct temperature measuring transducer,  
including mounting flange, calibratable,  
with multi-range switching and active output

Calibratable mean-value temperature measuring transducer **THERMASGARD® MWTM** (rod sensor 0.4...20 m) with eight switchable measuring ranges, continuous output, in an impact-resistant plastic housing with quick-locking screws, optionally with/without display, with bendable sensor rod (fully active), protective tube made from copper, plastic-coated, and anti-kink spring, incl. mounting flange.

Calibratable mean-value temperature measuring transducer **THERMASGARD® MWTM-SD** (rod sensor 3 m / 6 m) with eight switchable measuring ranges, continuous output, in an impact-resistant plastic housing with snap-on lid, with bendable sensor rod (fully active), protective tube made from reinforced thermoplastic hose and anti-kink spring, incl. mounting flange.

The sensor is used to detect the mean temperature (mean value) in gaseous media, e.g. in ventilation and air conditioning ducts over the entire cross section or over a defined length. Laid along a meandering route, it uniformly detects the surrounding temperature, as a duct temperature sensor. For proper mounting of the rod, mounting clamps **MK-05-M** (accessories) are available. The sensor is factory-calibrated; an environmental precision adjustment by an expert is possible.

**MWTM**

Rod length 0.4 m  
(IP 65)



**TECHNICAL DATA**

Power supply:	24 V AC / DC (± 10 %) for U variant 15...36 V DC for I variant, depending on working resistance, residual ripple stabilised ± 0.3 V
Working resistance:	$R_a \text{ (ohm)} = (U_b - 14 \text{ V}) / 0.02 \text{ A}$ for I variant
Load resistance:	$R_L > 5 \text{ kOhm}$ for U variant
Power consumption:	< 1.0 VA / 24 V DC; < 2.2 VA / 24 V AC
Sensor:	Pt1000, DIN EN 60751, class B
Measuring ranges:	<b>multi-range switching with 8 switchable measuring ranges,</b> see table (other ranges optional) $T_{\min} -30 \text{ }^\circ\text{C}$ , $T_{\max} +80 \text{ }^\circ\text{C}$ <b>with manual zero point correction (± 10 K)</b>
Output:	0 - 10 V or 4...20 mA
Connection type:	2- or 3-wire connection
<b>Sensors:</b>	active across the entire length (averaging)
Rod material:	<b>protective tube made from copper, plastic-coated (MWTM)</b> (made from reinforced thermoplastic hose for the <b>MWTM-SD</b> ), with anti-kink spring and sleeve, stainless steel V4A (1.4571)
Rod dimensions:	$\varnothing = 5.0 \text{ mm}$ , nominal length (NL) = 0.4 m / 3 m / 6 m, see table (nominal length optionally up to max. 20 m)
Rod laying:	<b>Observe the admissible values!</b> Bending radius: <b>&gt; 35 mm</b> Vibration load: <b>≤ 0.5 g</b> Tensile load: <b>&lt; 480 N</b> for the <b>MWTM</b> <b>&lt; 100 N</b> for the <b>MWTM-SD</b>
Housing:	plastic, UV-resistant, material polyamide, 30 % glass-globe reinforced, with quick-locking screws (slotted / Phillips head combination), colour traffic white (similar to RAL 9016), housing cover for display is transparent!
Housing dimensions:	72 x 64 x 37.8 mm (Tyr 1 without display) 72 x 64 x 43.3 mm (Tyr 1 with display)
Cable connection:	<b>cable gland</b> , plastic (M 16 x 1.5; with strain relief, exchangeable, max. inner diameter 10.4 mm) or <b>M12 connector</b> according to DIN EN 61076-2-101 (optional on request)
Electrical connection:	0.14 - 1.5 mm <sup>2</sup> via terminal screws on circuit board
Process connection:	by mounting flange, plastic (galvanised steel optional, see accessories) and mounting clamps <b>MK-05-M</b>
Ambient temperature:	measuring transducer -30...+70 °C
Humidity:	< 95 % r. H., non-precipitating air
Protection class:	III (according to EN 60730)
Protection type:	<b>IP 54</b> (according to EN 60529) for the <b>MWTM-SD</b> <b>IP 65</b> (according to EN 60529) for the <b>MWTM</b> housing tested, TÜV SÜD, report no. 713139052 (Tyr 1)
Standards:	CE conformity, electromagnetic compatibility according to EN 61326, according to EMC directive 2014 / 30 / EU
Optional:	Two-line <b>display with illumination</b> , cutout approx. 36 x 15 mm (W x H), for displaying the <b>ACTUAL temperature</b> and the <b>internal diagnostics</b> (measuring range exceeded, measuring range not reached, sensor breakage, sensor short circuit)
<b>ACCESSORIES</b>	see table

Display and internal diagnostics  
**THERMASGARD®**  
**Measuring transducer with display**



Standard



Measuring range exceeded



Measuring range not reached



Sensor breakage



Sensor short circuit



S+S REGELTECHNIK

**THERMASGARD® MWTM**  
**THERMASGARD® MWTM-SD**

Mean value / rod / duct temperature measuring transducer,  
including mounting flange, calibratable,  
with multi-range switching and active output

Dimensional drawing

MWTM

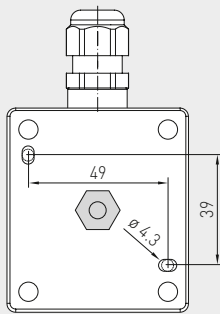

M12 connector  
(optional on request)

without display

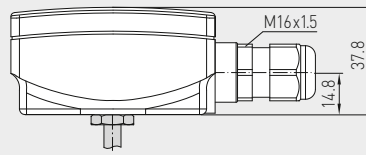
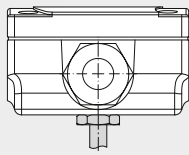

with display

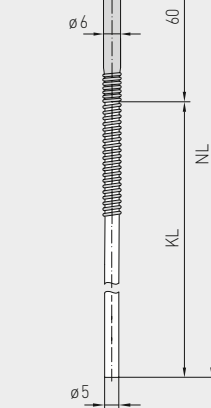
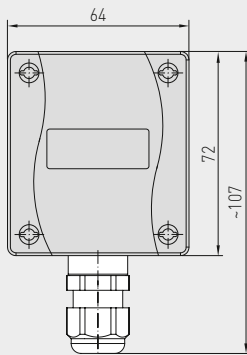
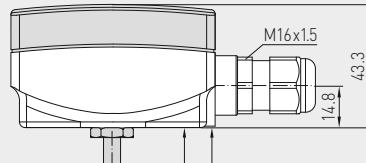
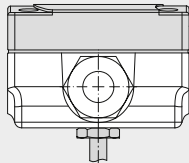

**MWTM**  
Rod length 3 m / 6 m  
(IP65)



**MWTM**  
with Display  
(IP65)



**MWTM-SD**  
Rod length 3 m / 6 m  
(IP54)



Measuring ranges (adjustable)	DIP 1	DIP 2	DIP 3
-20... +150 °C	ON	ON	ON
-50... +50 °C	OFF	ON	ON
-20... +80 °C	ON	OFF	ON
-30... +60 °C	OFF	OFF	ON
0... +40 °C	ON	ON	OFF
0... +50 °C (default)	OFF	ON	OFF
0... +100 °C	ON	OFF	OFF
0... +150 °C	OFF	OFF	OFF

Mean value / rod / duct temperature measuring transducer,  
 including mounting flange, calibratable,  
 with multi-range switching and active output

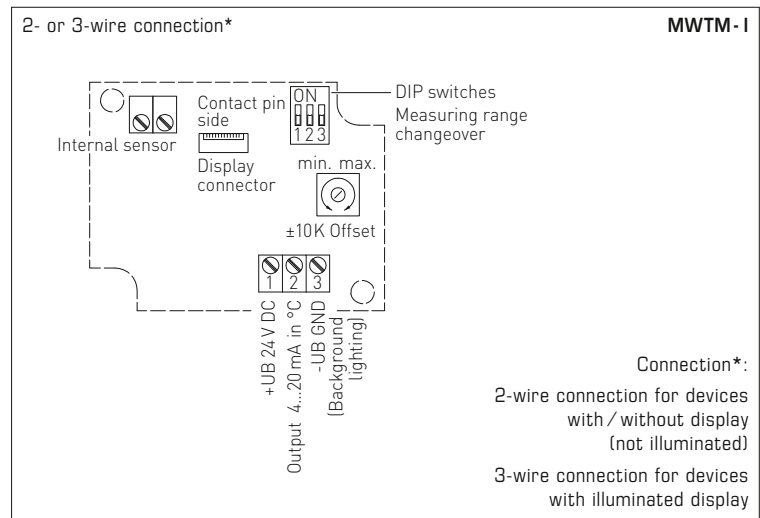
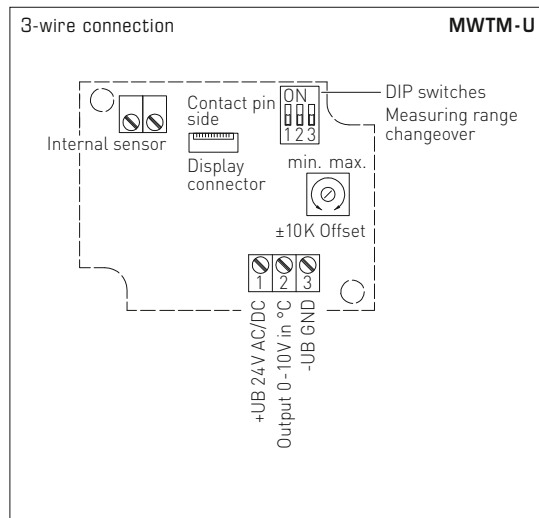

**MWTM**  
 display hinged (optional)



**Dependency of output voltage on output current**

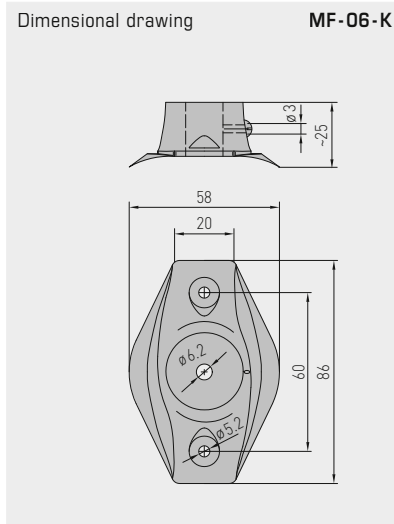
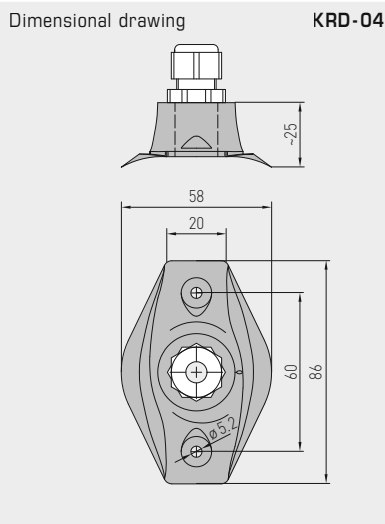
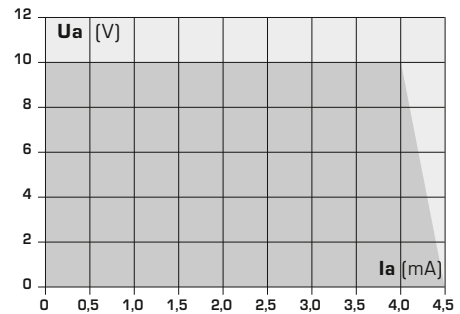

**MF-06-K**  
 Mounting flange, plastic  
 (Included in the scope of delivery)



**KRD-04**  
 Capillary tube bushing, plastic (optional)

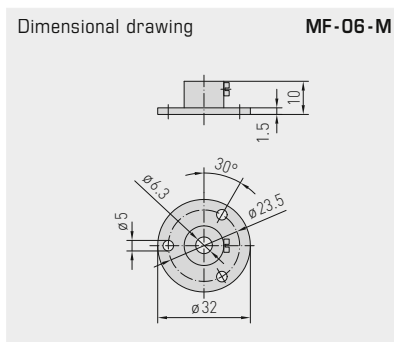
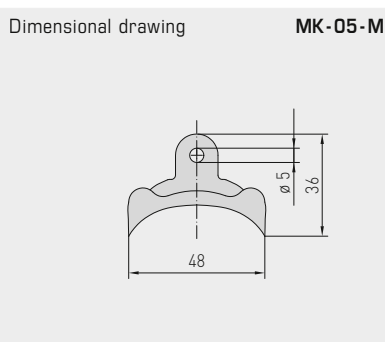

**MF-06-M**  
 Mounting flange, metal (optional)



**MK-05-M**  
 Mounting clamps, galvanised steel (from 3m rod length, included in the scope of delivery)







S+S REGELTECHNIK

**THERMASGARD® MWTM**  
**THERMASGARD® MWTM-SD**

Mean value / rod / duct temperature measuring transducer,  
including mounting flange, calibratable,  
with multi-range switching and active output



**MWTM**  
Rod length 3 m / 6 m  
with/without Display  
(IP65)



**MWTM-SD**  
Rod length 3 m / 6 m  
without Display  
(IP54)

THERMASGARD® MWTM-SD		Mean-value temperature measuring transducer with rod made from reinforced thermoplastic hose, <i>Standard</i>			
Type / WG01B	Sensor	Output	Rod length	Item No.	Price
<b>MWTM-SD-I</b>					IP54, I variant
MWTM-SD-I 3m	Pt1000	4...20 mA	3.0 m	1101-3132-0239-90K	152,82 €
MWTM-SD-I 6m	Pt1000	4...20 mA	6.0 m	1101-3132-0269-90K	162,28 €
<b>MWTM-SD-U</b>					IP54, U variant
MWTM-SD-U 3m	Pt1000	0 - 10 V	3.0 m	1101-3131-0239-90K	149,61 €
MWTM-SD-U 6m	Pt1000	0 - 10 V	6.0 m	1101-3131-0269-90K	158,64 €
Optional:	Cable connection with <b>M12 connector</b> according to DIN EN 61076-2-101			on request	

THERMASGARD® MWTM		Mean-value temperature measuring transducer with rod made from copper, plastic-coated, <i>Premium</i>			
Type / WG01	Sensor	Output	Rod length	Item No.	Price
<b>MWTM-I</b>					IP65, I variant
MWTM-I 0,4m	Pt1000	4...20 mA	0.4 m	1101-3132-0089-900	163,19 €
MWTM-I 3m	Pt1000	4...20 mA	3.0 m	1101-3132-0239-900	212,18 €
MWTM-I 6m	Pt1000	4...20 mA	6.0 m	1101-3132-0269-900	247,33 €
<b>MWTM-U</b>					IP65, U variant
MWTM-U 0,4m	Pt1000	0 - 10 V	0.4 m	1101-3131-0089-900	163,19 €
MWTM-U 3m	Pt1000	0 - 10 V	3.0 m	1101-3131-0239-900	212,18 €
MWTM-U 6m	Pt1000	0 - 10 V	6.0 m	1101-3131-0269-900	247,33 €
Extra charge:	Other ranges optional			24,19 €	
	Two-line <b>display</b> with illumination			47,46 €	
	Per meter sensor cable (from 6m to max. 20m)			on request	
Optional:	Cable connection with <b>M12 connector</b> according to DIN EN 61076-2-101			on request	

ACCESSORIES			
<b>MF-06-K</b>	<b>Mounting flange, plastic</b> (included in the scope of delivery)	7100-0030-1000-000	5,83 €
<b>MF-06-M</b>	<b>Mounting flange, metal</b> (Galvanised steel), Ø 35 mm	7100-0030-5000-100	9,10 €
<b>KRD-04</b>	<b>Capillary tube gland bracket, plastic</b>	7100-0030-7000-000	8,49 €
<b>MK-05-M</b>	<b>Mounting clamps, galvanised steel</b> (6 pieces) (from 3 m rod length, included in the scope of delivery)	7100-0034-0000-000	9,41 €

For further information see last chapter!

**Immersion / screw-in / duct temperature measuring transducer, calibratable, with multi-range switching and active output**

**TM 54**  
Basic unit

Calibratable temperature measuring transducer **THERMASGARD® TM 54** with eight switchable measuring ranges and continuous output, with connecting head made from aluminium (optionally with **cable gland** or **M12 connector** according to DIN EN 61076-2-101) and straight protective tube.

A basic unit in four variants through combination with accessories, eg, for robust applications with a separate immersion sleeve made from stainless steel.

The duct sensor is used to detect temperatures in liquid or gaseous media. It is used in pipes, heating engineering, storage systems, compact district heating stations, warm and cold water systems, oil and lubrication cycle systems, mechanical, apparatus and plant engineering and throughout the industrial sector.

The sensor is factory-calibrated; an environmental precision adjustment by an expert is possible.



**TECHNICAL DATA**

Power supply:	24 V AC / DC (± 10%) for U variant 15...36 V DC for I variant, depending on working resistance, residual ripple stabilised ± 0.3 V
Working resistance:	$R_b \text{ (ohm)} = (U_b - 14 \text{ V}) / 0.02 \text{ A}$ for I variant
Load resistance:	$R_L > 5 \text{ kOhm}$ for U variant
Power consumption:	< 1.0 VA / 24 V AC / DC; < 0.55 VA / 24 V DC
Sensor:	Pt1000, DIN EN 60571, class B <b>(Perfect Sensor Protection)</b>
Measuring ranges:	<b>multi-range switching with 8 switchable measuring ranges, see table (other ranges optional)</b> $T_{max} = +150^\circ\text{C}$ <b>with manual zero point correction (± 10 K)</b>
Deviation, temperature:	typically ± 0.2 K at +25 °C
Output:	0 - 10 V or 4...20 mA
Connection type:	2- or 3-wire connection
Electrical connection:	0.2 - 1.5 mm <sup>2</sup> , via push-in terminal
Cable connection:	<b>TM 54</b> (standard) adjusting screw made of metal (M 20 x 1.5) <b>TM 54-KV</b> (optional) cable gland, brass, nickel-plated (M 20 x 1.5; with strain relief, exchangeable, inner diameter 6 - 12 mm) <b>TM 54-Q</b> (optional) M12 connector according to DIN EN 61076-2-101 (male, 5-pin, A-code)
Dimensions:	see dimensional drawing
Connecting head:	form B, material aluminium, colour white aluminium (similar to RAL 9006), ambient temperature -30...+70 °C
Protective tube:	stainless steel, V4A (1.4571) Ø = 6 mm, inserted length (EL) = 50 - 400 mm (see table)
Process connection:	by means of immersion sleeve or mounting flange (accessories)
Humidity:	< 95 % r. H., non-precipitating air
Protection class:	III (according to EN 60 730)
Protection type:	<b>IP 54</b> (according to EN 60 529) <b>TM 54</b> <b>IP 65</b> (according to EN 60 529) <b>TM 54-KV / TM 54-Q</b>
Standards:	CE conformity, electromagnetic compatibility according to EN 61 326, EMC directive 2014 / 30 / EU
<b>ACCESSORIES</b>	(see table)
<b>TH-ms / xx</b>	<b>Immersion sleeve, brass, nickel-plated,</b> Ø = 8 mm, $T_{max} = +150^\circ\text{C}$ , $p_{max} = 10 \text{ bar}$
<b>TH-VA / xx</b>	<b>Immersion sleeve, stainless steel, V4A (1.4571),</b> Ø = 8 mm, $T_{max} = +600^\circ\text{C}$ , $p_{max} = 40 \text{ bar}$
<b>TH-VA / xx / 90</b>	<b>Immersion sleeve, stainless steel, V4A (1.4571),</b> with neck tube (90 mm), Ø = 8 mm, $T_{max} = +600^\circ\text{C}$ , $p_{max} = 40 \text{ bar}$
<b>MF-06-M</b>	<b>Mounting flange, metal, galvanised steel, Ø = 32 mm,</b> Ø = 6.3 mm tube gland, $T_{max} = +700^\circ\text{C}$



Immersion / screw-in / duct temperature measuring transducer, calibratable, with multi-range switching and active output

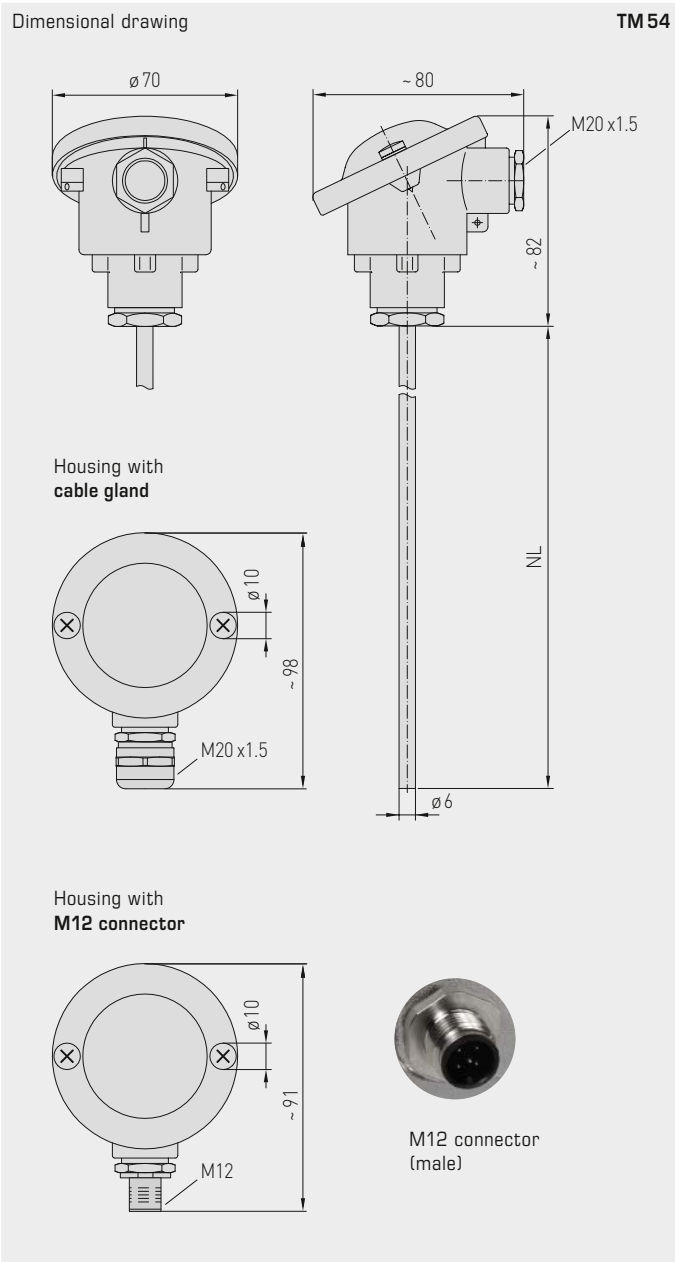

**TM 54**  
standard  
(IP 54)



**TM 54-KV**  
with cable gland  
(IP 65)



**TM 54-Q**  
with M12 connector  
(IP 65)



High-performance encapsulation against vibration, mechanical stress and humidity



Immersion / screw-in / duct temperature measuring transducer,  
calibratable, with multi-range switching  
and active output

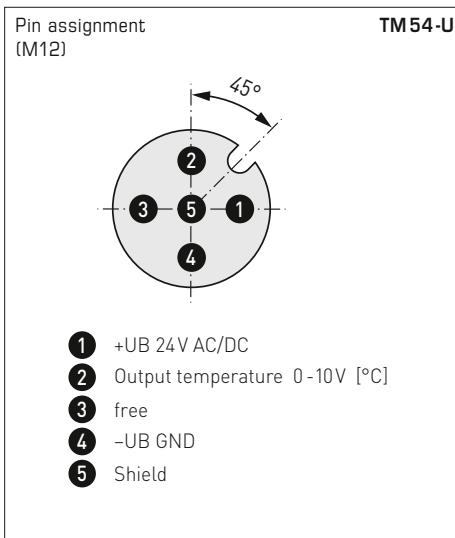
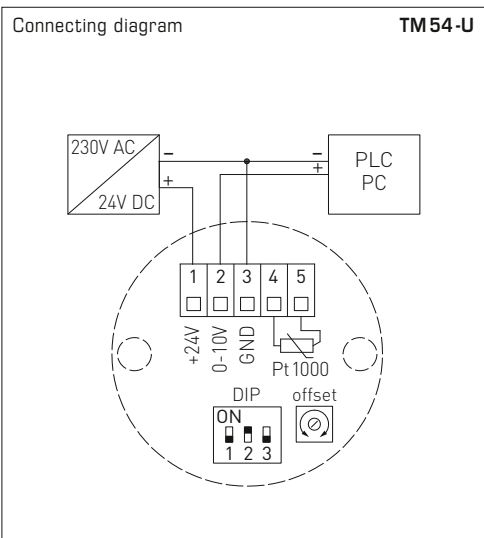

**TM 54-U**  
Connecting head

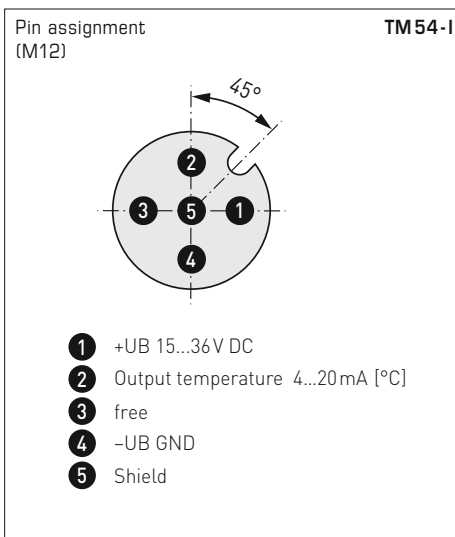
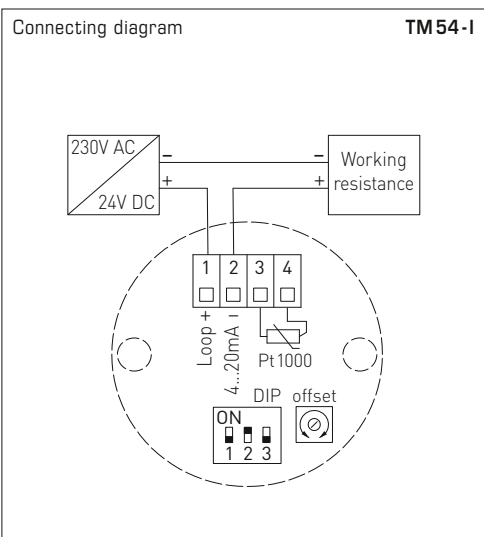

**TM 54-I**  
Connecting head



Measuring ranges (adjustable)	DIP 1	DIP 2	DIP 3
-20... +150 °C	ON	ON	ON
-50... +50 °C	OFF	ON	ON
-20... +80 °C	ON	OFF	ON
-30... +60 °C	OFF	OFF	ON
0... +40 °C	ON	ON	OFF
0... +50 °C (default)	OFF	ON	OFF
0...+100 °C	ON	OFF	OFF
0...+150 °C	OFF	OFF	OFF



TM 54  
standard  
(IP 54)



THERMASGARD® TM 54		Temperature measuring transducer (Basic unit)			
Type / WG01	Sensor	Output	Installation length (EL)	Item No.	Price
<b>TM 54 - I</b>				<b>IP 54, I - variant</b>	
TM54-I 50mm	Pt1000	4...20 mA	50 mm	1101-7152-0019-910	144,64 €
TM54-I 100mm	Pt1000	4...20 mA	100 mm	1101-7152-0029-910	148,05 €
TM54-I 150mm	Pt1000	4...20 mA	150 mm	1101-7152-0039-910	154,71 €
TM54-I 200mm	Pt1000	4...20 mA	200 mm	1101-7152-0049-910	156,83 €
TM54-I 250mm	Pt1000	4...20 mA	250 mm	1101-7152-0059-910	158,77 €
TM54-I 300mm	Pt1000	4...20 mA	300 mm	1101-7152-0069-910	160,40 €
TM54-I 350mm	Pt1000	4...20 mA	350 mm	1101-7152-0079-910	163,67 €
TM54-I 400mm	Pt1000	4...20 mA	400 mm	1101-7152-0089-910	172,79 €
<b>TM 54 - U</b>				<b>IP 54, U - variant</b>	
TM54-U 50mm	Pt1000	0 - 10 V	50 mm	1101-7151-0019-910	144,64 €
TM54-U 100mm	Pt1000	0 - 10 V	100 mm	1101-7151-0029-910	148,05 €
TM54-U 150mm	Pt1000	0 - 10 V	150 mm	1101-7151-0039-910	154,71 €
TM54-U 200mm	Pt1000	0 - 10 V	200 mm	1101-7151-0049-910	156,83 €
TM54-U 250mm	Pt1000	0 - 10 V	250 mm	1101-7151-0059-910	158,77 €
TM54-U 300mm	Pt1000	0 - 10 V	300 mm	1101-7151-0069-910	160,40 €
TM54-U 350mm	Pt1000	0 - 10 V	350 mm	1101-7151-0079-910	163,68 €
TM54-U 400mm	Pt1000	0 - 10 V	400 mm	1101-7151-0089-910	172,79 €
<b>Housing variant:</b>	equipped as standard with pressure screw (IP 54), optional housing variants with cable gland (IP 65) or M12 connector (IP 65) see the next page!				
Extra charge:	other measuring ranges optional				24,19 €



Immersion/screw-in/duct temperature measuring transducer,  
calibratable, with multi-range switching  
and active output

**TM 54 - Q**  
with M12 connector  
(IP 65)



**THERMASGARD®** Temperature measuring transducer  
**TM 54 - Q** (Basic unit with M12 connector)

Type/WG01	Sensor	Output	Installation length (EL)	Q	Item No.	Price
				●	IP 65, I - variant	
<b>TM 54-I xx Q</b>						
TM54-I 50mm Q	Pt1000	4...20 mA	50 mm	●	2001-4111-2100-011	184,57 €
TM54-I 100mm Q	Pt1000	4...20 mA	100 mm	●	2001-4111-2100-021	187,96 €
TM54-I 150mm Q	Pt1000	4...20 mA	150 mm	●	2001-4111-2100-031	194,63 €
TM54-I 200mm Q	Pt1000	4...20 mA	200 mm	●	2001-4111-2100-041	196,75 €
TM54-I 250mm Q	Pt1000	4...20 mA	250 mm	●	2001-4111-2100-051	198,70 €
TM54-I 300mm Q	Pt1000	4...20 mA	300 mm	●	2001-4111-2100-061	200,34 €
TM54-I 350mm Q	Pt1000	4...20 mA	350 mm	●	2001-4111-2100-071	203,61 €
TM54-I 400mm Q	Pt1000	4...20 mA	400 mm	●	2001-4111-2100-081	212,71 €
				●	IP 54, U - variant	
<b>TM 54-U xx Q</b>						
TM54-U 50mm Q	Pt1000	0 - 10 V	50 mm	●	2001-4111-1100-011	167,55 €
TM54-U 100mm Q	Pt1000	0 - 10 V	100 mm	●	2001-4111-1100-021	187,96 €
TM54-U 150mm Q	Pt1000	0 - 10 V	150 mm	●	2001-4111-1100-031	194,63 €
TM54-U 200mm Q	Pt1000	0 - 10 V	200 mm	●	2001-4111-1100-041	196,75 €
TM54-U 250mm Q	Pt1000	0 - 10 V	250 mm	●	2001-4111-1100-051	198,70 €
TM54-U 300mm Q	Pt1000	0 - 10 V	300 mm	●	2001-4111-1100-061	200,34 €
TM54-U 350mm Q	Pt1000	0 - 10 V	350 mm	●	2001-4111-1100-071	203,61 €
TM54-U 400mm Q	Pt1000	0 - 10 V	400 mm	●	2001-4111-1100-081	212,71 €
<b>Housing variant "Q":</b>		Cable connection with M12 connector (male, 5-pin, A-code)				
Extra charge:		other measuring ranges optional				24,19 €

**ACCESSORIES**

Special accessories for M12 connector  
see chapter Accessories!



Immersion / screw-in / duct temperature measuring transducer,  
calibratable, with multi-range switching  
and active output

TM 54 - KV  
with cable gland  
(IP 65)



THERMASGARD®		Temperature measuring transducer (Basic unit with cable gland)			
Type / WG01	Sensor	Output	Installation length (EL)	Item No.	Price
<b>TM 54 - I xx KV</b>				<b>IP 65, I - variant</b>	
TM54-I 50mm KV	Pt1000	4...20mA	50 mm	1101-7172-0019-910	153,63 €
TM54-I 100mm KV	Pt1000	4...20mA	100 mm	1101-7172-0029-910	157,03 €
TM54-I 150mm KV	Pt1000	4...20mA	150 mm	1101-7172-0039-910	163,68 €
TM54-I 200mm KV	Pt1000	4...20mA	200 mm	1101-7172-0049-910	165,81 €
TM54-I 250mm KV	Pt1000	4...20mA	250 mm	1101-7172-0059-910	167,76 €
TM54-I 300mm KV	Pt1000	4...20mA	300 mm	1101-7172-0069-910	169,40 €
TM54-I 350mm KV	Pt1000	4...20mA	350 mm	1101-7172-0079-910	172,66 €
TM54-I 400mm KV	Pt1000	4...20mA	400 mm	1101-7172-0089-910	181,76 €
<b>TM 54 - U xx KV</b>				<b>IP 65, U - variant</b>	
TM54-U 50mm KV	Pt1000	0 - 10 V	50 mm	1101-7171-0019-910	153,63 €
TM54-U 100mm KV	Pt1000	0 - 10 V	100 mm	1101-7171-0029-910	157,03 €
TM54-U 150mm KV	Pt1000	0 - 10 V	150 mm	1101-7171-0039-910	163,68 €
TM54-U 200mm KV	Pt1000	0 - 10 V	200 mm	1101-7171-0049-910	165,81 €
TM54-U 250mm KV	Pt1000	0 - 10 V	250 mm	1101-7171-0059-910	167,76 €
TM54-U 300mm KV	Pt1000	0 - 10 V	300 mm	1101-7171-0069-910	169,40 €
TM54-U 350mm KV	Pt1000	0 - 10 V	350 mm	1101-7171-0079-910	172,66 €
TM54-U 400mm KV	Pt1000	0 - 10 V	400 mm	1101-7171-0089-910	181,76 €
<b>Housing variant "KV":</b>	Cable connection with cable gland				
Extra charge:	other measuring ranges optional				24,19 €

Immersion / screw-in / duct temperature measuring transducer, calibratable, with multi-range switching and active output

One basic device in four variants ...



**TM54 + TH -ms/xx**

Immersion / screw-in temperature sensor with immersion sleeve, brass, nickel-plated



**TM54 + TH -VA/xx**

Immersion / screw-in temperature sensor with immersion sleeve, stainless steel, V4A



**TM54 + TH -VA/xx/90**

Immersion / screw-in temperature sensor with immersion sleeve with neck tube, stainless steel, V4A



**TM54 + MF-06-M**

Duct temperature sensor with mounting flange, metal

**Dimensional drawing TH -ms/xx**

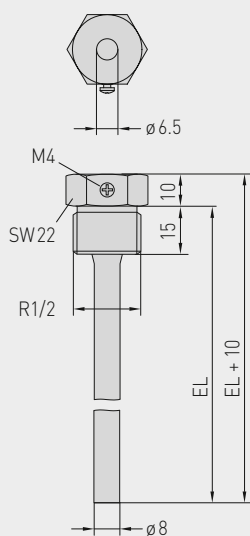

**Dimensional drawing TH -VA/xx**

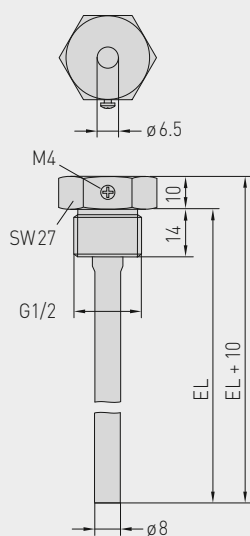

**Dimensional drawing TH -VA/xx/90**

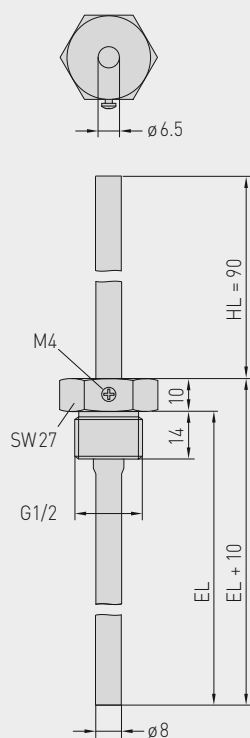

**Dimensional drawing MF-06-M**

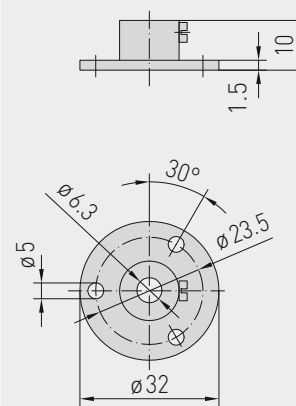



...through combination with accessories:



**TH - ms / xx**  
Immersion sleeve,  
brass, nickel-plated,  
thread-sealing, conical,  
according to DIN 10226



**TH - VA / xx**  
Immersion sleeve,  
stainless steel, V4A,  
flat-sealing, cylindrical,  
according to DIN 228



**TH - VA / xx / 90**  
Immersion sleeve with neck tube,  
stainless steel, V4A,  
flat-sealing, cylindrical,  
according to DIN 228



**MF-06-M**  
Mounting flange,  
metal

THERMASGARD® TH Immersion sleeve Ø 8 mm (accessories)					
Type / WG01	p <sub>max</sub> (static)	T <sub>max</sub>	Inserted Length (EL)	Item No.	Price
<b>TH - ms / xx</b> Brass nickel-plated					
without neck tube					
TH-MS 50MM	10 bar	+150 °C	50 mm	7100-0011-0010-001	8,87 €
TH-MS 100MM	10 bar	+150 °C	100 mm	7100-0011-0020-001	10,10 €
TH-MS 150MM	10 bar	+150 °C	150 mm	7100-0011-0030-001	10,67 €
TH-MS 200MM	10 bar	+150 °C	200 mm	7100-0011-0040-001	11,01 €
TH-MS 250MM	10 bar	+150 °C	250 mm	7100-0011-0050-001	12,75 €
TH-MS 300MM	10 bar	+150 °C	300 mm	7100-0011-0060-001	13,10 €
TH-MS 350MM	10 bar	+150 °C	350 mm	7100-0011-0070-001	13,21 €
TH-MS 400MM	10 bar	+150 °C	400 mm	7100-0011-0080-001	13,33 €
<b>TH - VA / xx</b> Stainless steel, V4A (1.4571)					
without neck tube					
TH-VA 50MM	40 bar	+600 °C	50 mm	7100-0012-0010-001	19,31 €
TH-VA 100MM	40 bar	+600 °C	100 mm	7100-0012-0020-001	21,34 €
TH-VA 150MM	40 bar	+600 °C	150 mm	7100-0012-0030-001	22,93 €
TH-VA 200MM	40 bar	+600 °C	200 mm	7100-0012-0040-001	24,17 €
TH-VA 250MM	40 bar	+600 °C	250 mm	7100-0012-0050-001	30,05 €
TH-VA 300MM	40 bar	+600 °C	300 mm	7100-0012-0060-001	31,40 €
TH-VA 350MM	40 bar	+600 °C	350 mm	7100-0012-0070-001	31,61 €
TH-VA 400MM	40 bar	+600 °C	400 mm	7100-0012-0080-001	32,17 €
<b>TH - VA / xx / 90</b> Stainless steel, V4A (1.4571)					
with neck tube (90 mm)					
TH-VA 50/90MM	40 bar	+600 °C	50 mm	7100-0012-2010-001	27,66 €
TH-VA 100/90MM	40 bar	+600 °C	100 mm	7100-0012-2020-001	28,90 €
TH-VA 150/90MM	40 bar	+600 °C	150 mm	7100-0012-2030-001	30,32 €
TH-VA 200/90MM	40 bar	+600 °C	200 mm	7100-0012-2040-001	31,61 €
TH-VA 250/90MM	40 bar	+600 °C	250 mm	7100-0012-2050-001	33,13 €
TH-VA 300/90MM	40 bar	+600 °C	300 mm	7100-0012-2060-001	35,91 €

Note: inner diameter of socket 6.5 mm  
For further information see last chapter!

Mounting flange (accessories)

Type / WG01	T <sub>max</sub>	Item No.	Price
<b>MF</b>			
<b>MF-06-M</b>	Mounting flange, metal (galvanised steel) Ø 32 mm, tube gland Ø 6.3 mm	+700 °C	7100-0030-5000-100
9,10 €			

Note: For further information see last chapter!

Duct/smoke gas temperature measuring transducer, including mounting flange, calibratable, with multi-range switching and active output

Calibratable smoke gas temperature measuring transducer **THERMASGARD® RGTM 1** with eight switchable measuring ranges and continuous output, with connecting head made from aluminium (optionally with **cable gland** or **M12 connector** according to DIN EN 61076-2-101), spring-mounted measuring insert and straight protective tube, incl. mounting flange.

The duct sensor is used to detect high temperatures in gaseous media, eg. for exhaust air or smoke gas temperature measurement.

The sensor is factory-calibrated; an environmental precision adjustment by an expert is possible.

**RGTM 1**  
Basic unit

**TECHNICAL DATA**

Power supply:	24 V AC / DC (± 10 %) for U variant 15...36 V DC for I variant, depending on working resistance, residual ripple stabilised ± 0.3 V
Working resistance:	$R_b \text{ (Ohm)} = (U_b - 14 \text{ V}) / 0.02 \text{ A}$ for I variant
Load resistance:	10 kOhm (load max. 1 mA) for U variant
Power consumption:	< 1.0 VA / 24 V AC / DC; < 0.55 VA / 24 V DC
Sensor:	Pt1000 (according to DIN EN 60751, class B) <b>(Perfect Sensor Protection)</b>
Measuring ranges:	<b>multi-range switching</b> <b>with 8 switchable measuring ranges,</b> see table (other ranges optional) <b>with manual zero point correction (± 10K)</b>
Deviation, temperature:	typically ± 0.2 K at +25 °C
Output:	0 - 10 V or 4...20 mA
Connection type:	2- or 3-wire connection
Electrical connection:	0.2 - 1.5 mm <sup>2</sup> , via push-in terminal
Cable connection:	<b>RGTM 1</b> (Standard) adjusting screw made of metal (M 20 x 1.5); <b>RGTM 1-KV</b> (optional) cable gland, brass, nickel-plated (M 20 x 1.5; with strain relief, exchangeable, inner diameter 6 - 12 mm) <b>RGTM 1-Q</b> (optional) M12 connector according to DIN EN 61076-2-101 (male, 5-pin, A-code)
Dimensions:	see dimensional drawing
Connecting head:	form B, material aluminium, colour white aluminium (similar to RAL 9006), ambient temperature -30...+70 °C
Protective tube:	stainless steel, V4A (1.4571), Ø = 8 mm inserted length (EL) = 200 - 400 mm (see table)
Process connection:	by mounting flange stainless steel <b>V2A</b> (1.4305) (included in the scope of delivery)
Humidity:	< 95 % r. H., non-precipitating air
Protection class:	III (according to EN 60 730)
Protection type:	<b>IP 54</b> (according to EN 60 529) <b>RGTM 1</b> <b>IP 65</b> (according to EN 60 529) <b>RGTM 1-KV / RGTM 1-Q</b>
Standards:	CE conformity, electromagnetic compatibility according to EN 61 326, EMC directive 2014 / 30 / EU



**RGTM 1**  
Measuring insert with ceramic tubelet





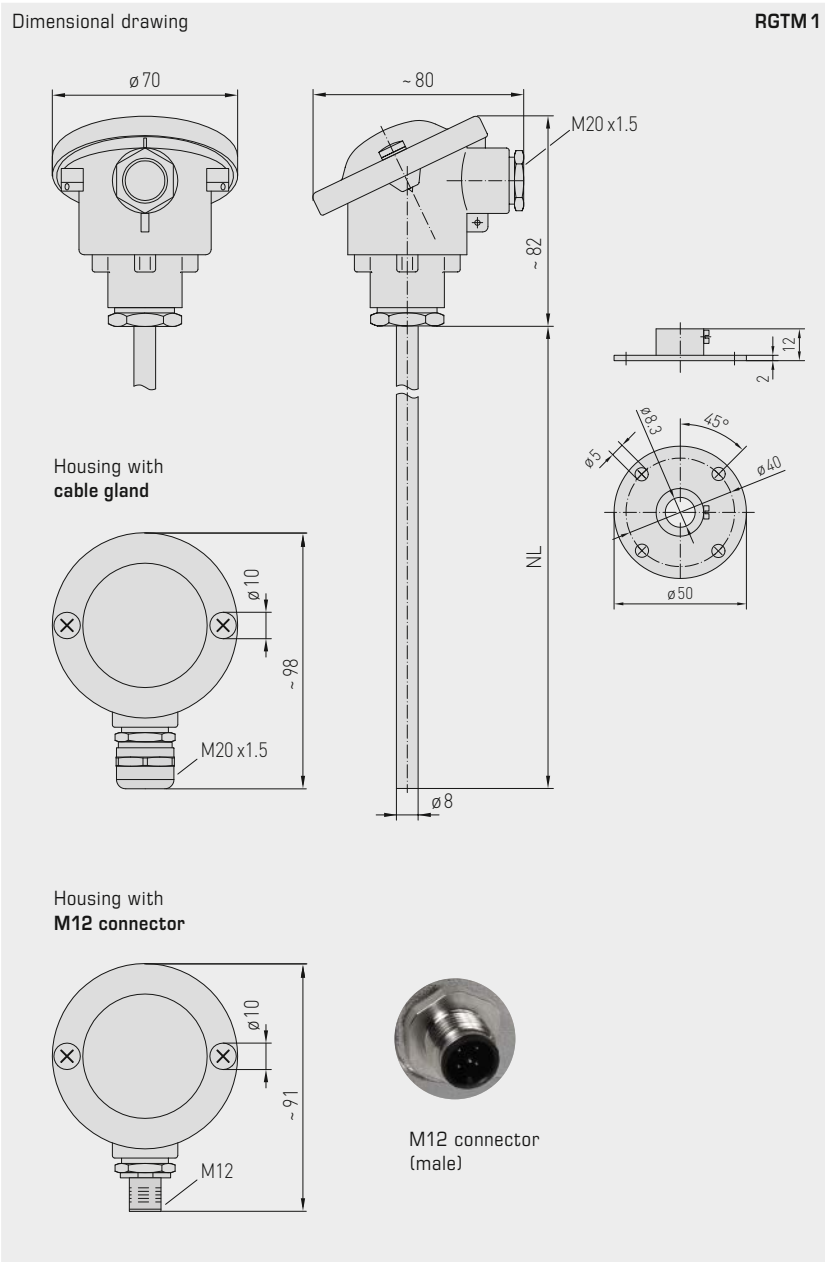

**RGTM 1**  
standard  
(IP 54)



**RGTM 1-KV**  
with cable gland  
(IP 65)



**RGTM 1-Q**  
with M12 connector  
(IP 65)



High-performance encapsulation against vibration, mechanical stress and humidity



Duct/smoke gas temperature measuring transducer, including mounting flange, calibratable, with multi-range switching and active output

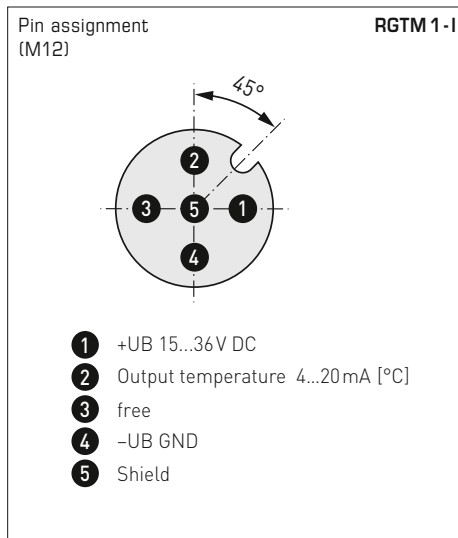
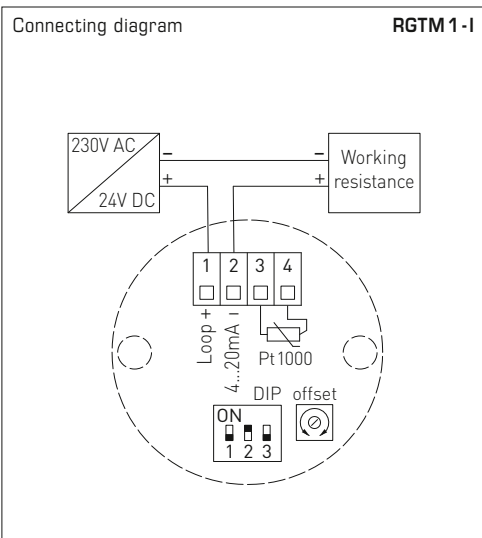
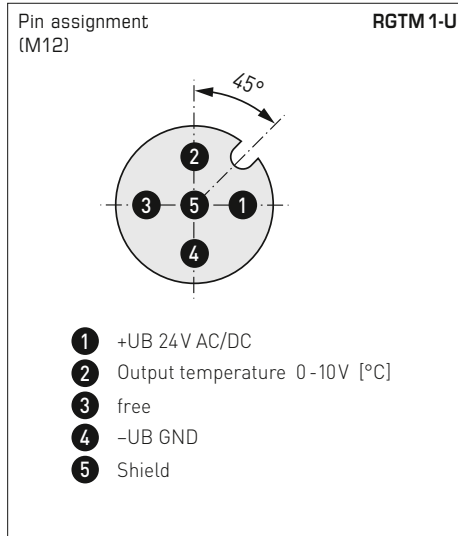
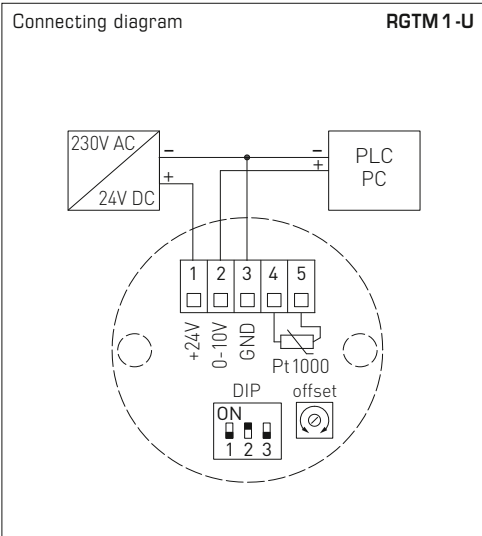

Measuring ranges (adjustable)	DIP 1	DIP 2	DIP 3
-20...+150 °C	ON	ON	ON
0...+50 °C (default)	OFF	ON	ON
0...+100 °C	ON	OFF	ON
0...+200 °C	OFF	OFF	ON
0...+300 °C	ON	ON	OFF
0...+400 °C	OFF	ON	OFF
0...+500 °C	ON	OFF	OFF
0...+600 °C	OFF	OFF	OFF



Duct/smoke gas temperature measuring transducer,  
including mounting flange, calibratable, with multi-range switching  
and active output

RGTM 1  
standard  
(IP54)



THERMASGARD® RGTM 1		Duct / smoke gas temperature sensor, incl. mounting flange (standard)			
Type / WG01	Sensor	Output	Installation length (EL)	Item No.	Price
<b>RGTM 1 - I</b>				<b>IP 54, I - variant</b>	
RGTM1-I 200mm	Pt1000	4...20mA	<b>200 mm</b>	1101-3122-0049-810	<b>274,61 €</b>
RGTM1-I 250mm	Pt1000	4...20mA	<b>250 mm</b>	1101-3122-0059-810	<b>285,52 €</b>
RGTM1-I 300mm	Pt1000	4...20mA	<b>300 mm</b>	1101-3122-0069-810	<b>288,55 €</b>
RGTM1-I 400mm	Pt1000	4...20mA	<b>400 mm</b>	1101-3122-0089-810	<b>290,97 €</b>
<b>RGTM 1 - U</b>				<b>IP 54, U - variant</b>	
RGTM1-U 200mm	Pt1000	0 - 10 V	<b>200 mm</b>	1101-3121-0049-810	<b>274,61 €</b>
RGTM1-U 250mm	Pt1000	0 - 10 V	<b>250 mm</b>	1101-3121-0059-810	<b>285,52 €</b>
RGTM1-U 300mm	Pt1000	0 - 10 V	<b>300 mm</b>	1101-3121-0069-810	<b>288,55 €</b>
RGTM1-U 400mm	Pt1000	0 - 10 V	<b>400 mm</b>	1101-3121-0089-810	<b>290,97 €</b>
<b>Housing variant:</b>	equipped as standard with pressure screw (IP54), optional housing variants with cable gland (IP65) or <b>M12 connector (IP65)</b> see the next page!				
Extra charge:	other measuring ranges optional				<b>24,19 €</b>

Duct/smoke gas temperature measuring transducer,  
including mounting flange, calibratable, with multi-range switching  
and active output

**RGTM 1 - Q**  
with M12 connector  
(IP 65)



THERMASGARD® RGTM 1 - Q		Duct / smoke gas temperature sensor, incl. mounting flange (with M12 connector)				
Type / WG01	Sensor	Output	Installation length (EL)	Q	Item No.	Price
<b>RGTM 1 - I xx Q</b>				<b>IP 65, I - variant</b>		
RGTM1-I 200mm Q	Pt1000	4...20 mA	200 mm	●	2001-4131-2100-011	314,53 €
RGTM1-I 250mm Q	Pt1000	4...20 mA	250 mm	●	2001-4131-2100-021	325,46 €
RGTM1-I 300mm Q	Pt1000	4...20 mA	300 mm	●	2001-4131-2100-031	328,47 €
RGTM1-I 400mm Q	Pt1000	4...20 mA	400 mm	●	2001-4131-2100-041	330,91 €
<b>RGTM 1 - U xx Q</b>				<b>IP 54, U - variant</b>		
RGTM1-U 200mm Q	Pt1000	0 - 10 V	200 mm	●	2001-4131-1100-011	314,53 €
RGTM1-U 250mm Q	Pt1000	0 - 10 V	250 mm	●	2001-4131-1100-021	325,46 €
RGTM1-U 300mm Q	Pt1000	0 - 10 V	300 mm	●	2001-4131-1100-031	328,47 €
RGTM1-U 400mm Q	Pt1000	0 - 10 V	400 mm	●	2001-4131-1100-041	330,91 €
<b>Housing variant "Q":</b>		Cable connection with M12 connector (male, 5-pin, A-code)				
Extra charge:	other measuring ranges optional					24,19 €

**ACCESSORIES**

Special accessories for M12 connector  
see chapter Accessories!



Duct/smoke gas temperature measuring transducer,  
including mounting flange, calibratable, with multi-range switching  
and active output

RGTM 1 - KV  
with cable gland  
(IP 65)



THERMASGARD® RGTM 1 - KV		Duct / smoke gas temperature sensor, incl. mounting flange (with cable gland)			
Type / WG01	Sensor	Output	Installation length (EL)	Item No.	Price
<b>RGTM 1 - I xx KV</b>				<b>IP 65, I - variant</b>	
RGTM1-I 200mm KV	Pt1000	4...20mA	200 mm	1101-31D2-0049-810	283,60 €
RGTM1-I 250mm KV	Pt1000	4...20mA	250 mm	1101-31D2-0059-810	294,52 €
RGTM1-I 300mm KV	Pt1000	4...20mA	300 mm	1101-31D2-0069-810	297,54 €
RGTM1-I 400mm KV	Pt1000	4...20mA	400 mm	1101-31D2-0089-810	299,97 €
<b>RGTM 1 - U xx KV</b>				<b>IP 65, U - variant</b>	
RGTM1-U 200mm KV	Pt1000	0 - 10 V	200 mm	1101-31D1-0049-810	283,60 €
RGTM1-U 250mm KV	Pt1000	0 - 10 V	250 mm	1101-31D1-0059-810	294,52 €
RGTM1-U 300mm KV	Pt1000	0 - 10 V	300 mm	1101-31D1-0069-810	297,54 €
RGTM1-U 400mm KV	Pt1000	0 - 10 V	400 mm	1101-31D1-0089-810	299,97 €
<b>Housing variant "KV":</b>		<b>Cable connection with cable gland</b>			
Extra charge:	other measuring ranges optional				24,19 €



**Screw-in / smoke gas temperature measuring transducer, with neck tube, calibratable, with multi-range switching and active output**

**RGTM 2**  
Basic unit

Calibratable smoke gas / screw-in temperature measuring transducer with neck tube **THERMASGARD® RGTM 2** with eight switchable measuring ranges and continuous output, with connecting head made from aluminium (optionally with **cable gland** or **M12 connector** according to DIN EN 61076-2-101), spring-mounted measuring insert and straight protective tube.

The duct sensor is used to detect high temperatures in gaseous or liquid media, eg. for exhaust air or smoke gas temperature measurement.

The sensor is factory-calibrated; an environmental precision adjustment by an expert is possible.

**TECHNICAL DATA**

Power supply:	24 V AC / DC (± 10 %) for U variant 15...36 V DC for I variant, depending on working resistance, residual ripple stabilised ± 0.3 V
Working resistance:	$R_a \text{ (Ohm)} = (U_b - 14 \text{ V}) / 0.02 \text{ A}$ for I variant
Load resistance:	10 kOhm (load max. 1 mA) for U variant
Power consumption:	< 1.0 VA / 24 V AC / DC; < 0.55 VA / 24 V DC
Sensor:	Pt1000 (according to DIN EN 60 751, class B) <b>(Perfect Sensor Protection)</b>
Measuring ranges:	<b>multi-range switching</b> <b>with 8 switchable measuring ranges,</b> see table (other ranges optional) <b>with manual zero point correction (± 10 K)</b>
Deviation, temperature:	typically ± 0.2 K at +25 °C
Output:	0 - 10 V or 4...20 mA
Connection type:	2- or 3-wire connection
Electrical connection:	0.2 - 1.5 mm <sup>2</sup> , via push-in terminal
Cable connection:	<b>RGTM 2</b> (Standard) adjusting screw made of metal (M 20 x 1.5); <b>RGTM 2-KV</b> (optional) cable gland, brass, nickel-plated (M 20 x 1.5; with strain relief, exchangeable, inner diameter 6 - 12 mm) <b>RGTM 2-Q</b> (optional) M12 connector according to DIN EN 61076-2-101 (male, 5-pin, A-code)
Dimensions:	see dimensional drawing
Connecting head:	form B, material aluminium, colour white aluminium (similar to RAL 9006), ambient temperature -30...+70 °C
Protective tube:	stainless steel, <b>V4A</b> (1.4571), G ½" straight pipe thread, wrench size 27 mm, $p_{max} = 40 \text{ bar}$ , $\varnothing = 8 \text{ mm}$ length of neck tube (HL) = 80 mm inserted length (EL) = 100 - 400 mm (see table)
Process connection:	screwed socket with G ½"
Humidity:	< 95 % r. H., non-precipitating air
Protection class:	III (according to EN 60 730)
Protection type:	<b>IP 54</b> (according to EN 60 529) <b>RGTM 2</b> <b>IP 65</b> (according to EN 60 529) <b>RGTM 2-KV / RGTM 2-Q</b>
Standards:	CE conformity, electromagnetic compatibility according to EN 61 326, EMC directive 2014 / 30 / EU



**RGTM 2**  
Measuring insert with ceramic tubelet



S+S REGELTECHNIK

THERMASGARD® RGTM 2

Screw-in/smoke gas temperature measuring transducer, with neck tube, calibratable, with multi-range switching and active output

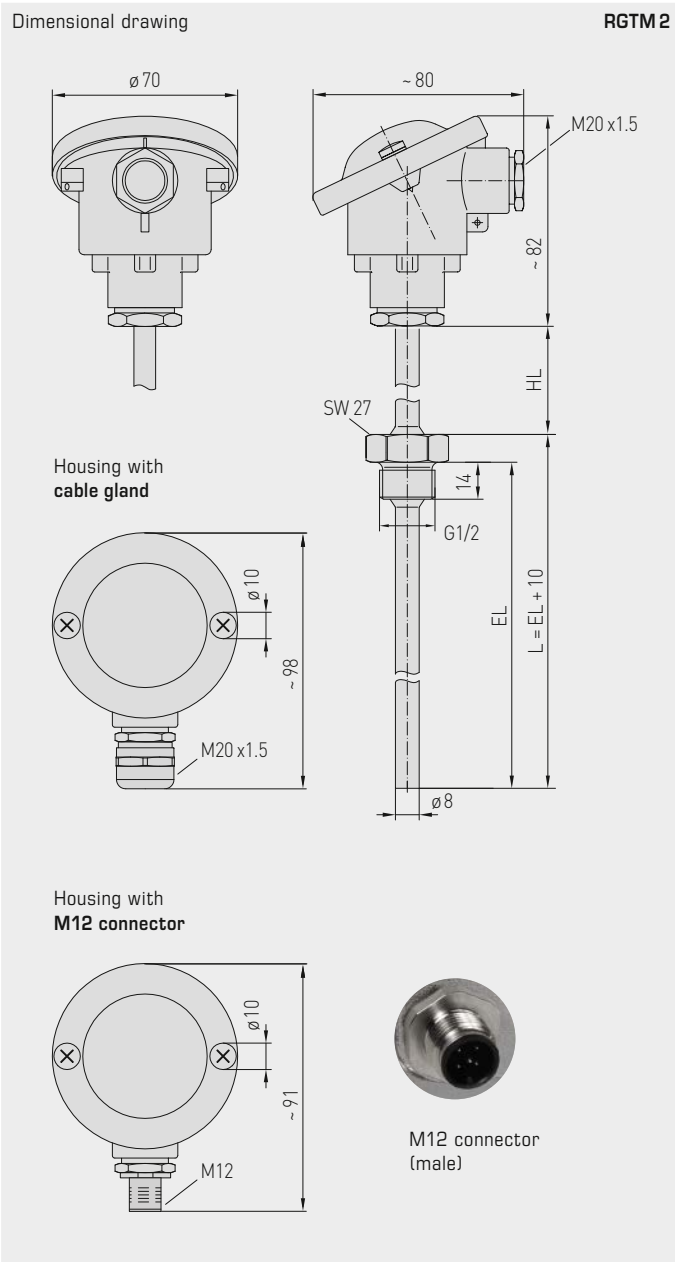

High-performance encapsulation against vibration, mechanical stress and humidity

**PS-PROTECTION**  
PERFECT SENSOR PROTECTION

**RGTM 2**  
standard  
(IP 54)



**RGTM 2-KV**  
with cable gland  
(IP 65)



**RGTM 2-Q**  
with M12 connector  
(IP 65)



Screw-in / smoke gas temperature measuring transducer,  
with neck tube, calibratable, with multi-range switching  
and active output

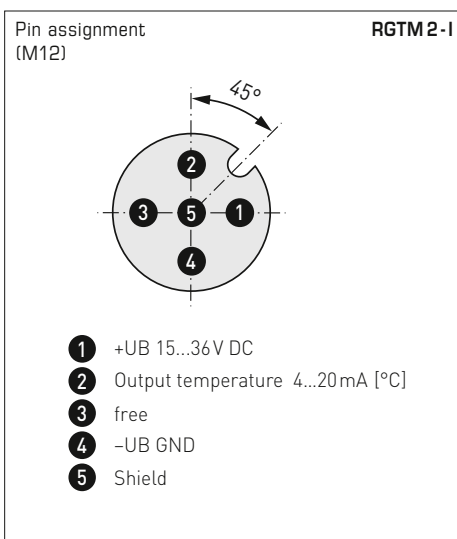
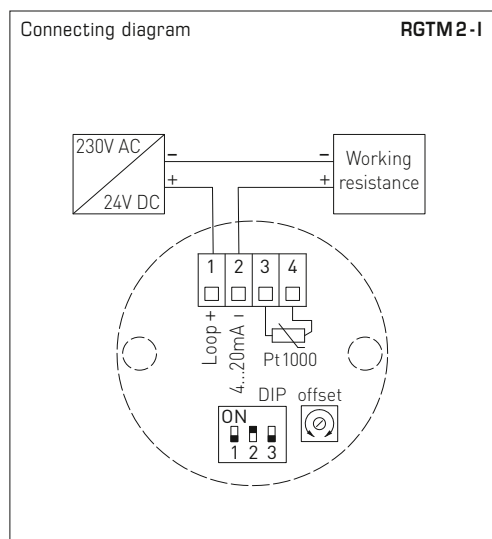
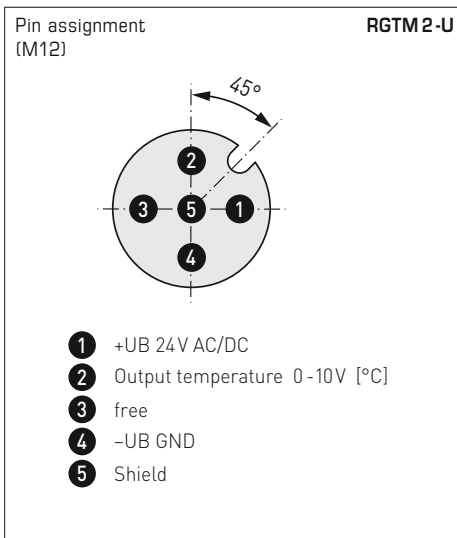
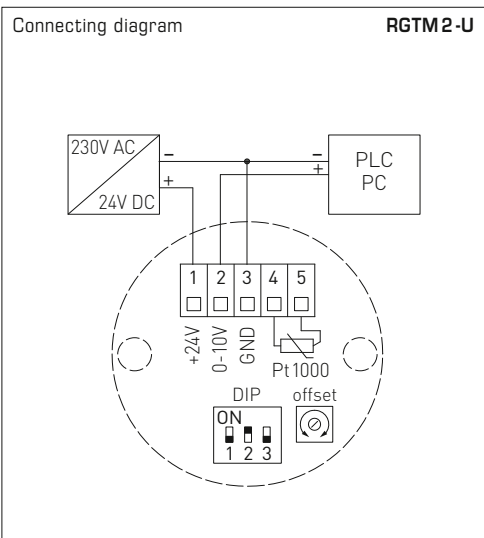

Measuring ranges (adjustable)	DIP 1	DIP 2	DIP 3
-20...+150 °C	ON	ON	ON
0...+50 °C (default)	OFF	ON	ON
0...+100 °C	ON	OFF	ON
0...+200 °C	OFF	OFF	ON
0...+300 °C	ON	ON	OFF
0...+400 °C	OFF	ON	OFF
0...+500 °C	ON	OFF	OFF
0...+600 °C	OFF	OFF	OFF



Screw-in / smoke gas temperature measuring transducer,  
with neck tube, calibratable, with multi-range switching  
and active output

RGTM 2  
standard  
(IP 54)



THERMASGARD® RGTM 2		Screw-in / smoke gas temperature measuring transducer with neck tube (standard)			
Type / WG01	Sensor	Output	Installation length (EL)	Item No.	Price
<b>RGTM 2 - I</b>				<b>IP 54, I - variant</b>	
RGTM2-I 100/80mm	Pt1000	4...20 mA	100 mm	1101-2162-0029-810	266,74 €
RGTM2-I 150/80mm	Pt1000	4...20 mA	150 mm	1101-2162-0039-810	271,58 €
RGTM2-I 200/80mm	Pt1000	4...20 mA	200 mm	1101-2162-0049-810	274,00 €
RGTM2-I 250/80mm	Pt1000	4...20 mA	250 mm	1101-2162-0059-810	284,91 €
RGTM2-I 300/80mm	Pt1000	4...20 mA	300 mm	1101-2162-0069-810	288,55 €
RGTM2-I 400/80mm	Pt1000	4...20 mA	400 mm	1101-2162-0089-810	289,77 €
<b>RGTM 2 - U</b>				<b>IP 54, U - variant</b>	
RGTM2-U 100/80mm	Pt1000	0 - 10 V	100 mm	1101-2161-0029-810	266,74 €
RGTM2-U 150/80mm	Pt1000	0 - 10 V	150 mm	1101-2161-0039-810	271,58 €
RGTM2-U 200/80mm	Pt1000	0 - 10 V	200 mm	1101-2161-0049-810	274,00 €
RGTM2-U 250/80mm	Pt1000	0 - 10 V	250 mm	1101-2161-0059-810	284,91 €
RGTM2-U 300/80mm	Pt1000	0 - 10 V	300 mm	1101-2161-0069-810	288,55 €
RGTM2-U 400/80mm	Pt1000	0 - 10 V	400 mm	1101-2161-0089-810	289,77 €
<b>Housing variant:</b>	equipped as standard with pressure screw (IP 54), optional housing variants with cable gland (IP 65) or M12 connector (IP 65) see the next page!				
Extra charge:	other measuring ranges optional				24,19 €

Screw-in / smoke gas temperature measuring transducer, with neck tube, calibratable, with multi-range switching and active output

RGTM 2 - Q  
with M12 connector  
(IP 65)



THERMASGARD®		Screw-in / smoke gas temperature measuring transducer with neck tube (with M12 connector)				
Type / WG01	Sensor	Output	Installation length (EL)	Q	Item No.	Price
<b>RGTM 2-I xx Q</b>				<b>IP 65, I - variant</b>		
RGTM2-I 100/80mm Q	Pt1000	4...20 mA	100 mm	●	2001-4141-2100-011	306,67 €
RGTM2-I 150/80mm Q	Pt1000	4...20 mA	150 mm	●	2001-4141-2100-021	311,52 €
RGTM2-I 200/80mm Q	Pt1000	4...20 mA	200 mm	●	2001-4141-2100-031	315,06 €
RGTM2-I 250/80mm Q	Pt1000	4...20 mA	250 mm	●	2001-4141-2100-041	324,84 €
RGTM2-I 300/80mm Q	Pt1000	4...20 mA	300 mm	●	2001-4141-2100-051	328,47 €
RGTM2-I 400/80mm Q	Pt1000	4...20 mA	400 mm	●	2001-4141-2100-061	329,70 €
<b>RGTM 2-U xx Q</b>				<b>IP 65, U - variant</b>		
RGTM2-U 100/80mm Q	Pt1000	0 - 10 V	100 mm	●	2001-4141-1100-011	306,67 €
RGTM2-U 150/80mm Q	Pt1000	0 - 10 V	150 mm	●	2001-4141-1100-021	311,52 €
RGTM2-U 200/80mm Q	Pt1000	0 - 10 V	200 mm	●	2001-4141-1100-031	315,06 €
RGTM2-U 250/80mm Q	Pt1000	0 - 10 V	250 mm	●	2001-4141-1100-041	324,84 €
RGTM2-U 300/80mm Q	Pt1000	0 - 10 V	300 mm	●	2001-4141-1100-051	328,47 €
RGTM2-U 400/80mm Q	Pt1000	0 - 10 V	400 mm	●	2001-4141-1100-061	329,70 €
<b>Housing variant "Q":</b>		Cable connection with M12 connector (male, 5-pin, A-code)				
Extra charge:		other measuring ranges optional				24,19 €

**ACCESSORIES**

Special accessories for M12 connector  
see chapter Accessories!





Screw-in / smoke gas temperature measuring transducer,  
with neck tube, calibratable, with multi-range switching  
and active output

RGTM 2 - KV  
with cable gland  
(IP 65)



THERMASGARD®		Screw-in / smoke gas temperature measuring transducer with neck tube (with cable gland)			
Type / WG01	Sensor	Output	Installation length (EL)	Item No.	Price
<b>RGTM 2-I xx KV</b>				<b>IP 65, I-variant</b>	
RGTM2-I 100/80mm KV	Pt1000	4...20mA	100 mm	1101-21D2-0029-810	275,72 €
RGTM2-I 150/80mm KV	Pt1000	4...20mA	150 mm	1101-21D2-0039-810	280,56 €
RGTM2-I 200/80mm KV	Pt1000	4...20mA	200 mm	1101-21D2-0049-810	282,99 €
RGTM2-I 250/80mm KV	Pt1000	4...20mA	250 mm	1101-21D2-0059-810	293,91 €
RGTM2-I 300/80mm KV	Pt1000	4...20mA	300 mm	1101-21D2-0069-810	297,54 €
RGTM2-I 400/80mm KV	Pt1000	4...20mA	400 mm	1101-21D2-0089-810	298,75 €
<b>RGTM 2-U xx KV</b>				<b>IP 65, U-variant</b>	
RGTM2-U 100/80mm KV	Pt1000	0-10 V	100 mm	1101-21D1-0029-810	275,72 €
RGTM2-U 150/80mm KV	Pt1000	0-10 V	150 mm	1101-21D1-0039-810	280,56 €
RGTM2-U 200/80mm KV	Pt1000	0-10 V	200 mm	1101-21D1-0049-810	282,99 €
RGTM2-U 250/80mm KV	Pt1000	0-10 V	250 mm	1101-21D1-0059-810	293,91 €
RGTM2-U 300/80mm KV	Pt1000	0-10 V	300 mm	1101-21D1-0069-810	297,54 €
RGTM2-U 400/80mm KV	Pt1000	0-10 V	400 mm	1101-21D1-0089-810	298,75 €
<b>Housing variant "KV":</b>		Cable connection with cable gland			
Extra charge:	other measuring ranges optional				24,19 €

**Sleeve sensor with temperature measuring transducer, calibratable, with multi-range switching and active output**

Calibratable temperature measuring transducer with sleeve sensor **THERMASGARD® HFTM** with eight switchable measuring ranges, continuous output, housing made from impact-resistant plastic with quick-release screws, optionally **with/without display**, with **cable gland** or **M12 connector** according to DIN EN 61076-2-101.

The temperature transmitter with remote sensor is used to detect temperatures in liquid and gaseous media e.g. if installed in an immersion sleeve or as a duct sensor. A direct, permanent use in liquids is possible in combination with immersion sleeves **THE** (see chapter Accessories).

The sensor is factory-calibrated; an environmental precision adjustment by an expert is possible.

**TECHNICAL DATA**

Power supply:	24 V AC / DC (± 10 %) for U variant 15...36 V DC for I variant, depending on working resistance, residual ripple stabilised ± 0.3 V
Working resistance:	$R_a(\text{ohm}) = (U_b - 14 \text{ V}) / 0.02 \text{ A}$ for I variant, see working resistance diagram
Load resistance:	$R_L > 5 \text{ kOhm}$ for U variant
Power consumption:	< 1.0 VA / 24 V DC; < 2.2 VA / 24 V AC
Insulating resistance:	≥ 100 MΩ, at +20 °C (500 V DC)
Sensor:	Pt1000, DIN EN 60751, class B <b>(Perfect Sensor Protection at IP68)</b> sensor external
Measuring ranges:	<b>multi-range switching</b> <b>with 8 switchable measuring ranges</b> see table (other measuring ranges optional) <b>with manual zero point correction (± 10 K)</b>
Deviation in temperature:	typically ± 0.2 K at +25 °C
Output:	0 - 10 V or 4...20 mA
Connection type:	2- or 3-wire connection
Electrical connection:	0.14 - 1.5 mm <sup>2</sup> , via screw terminals
Cable connection:	<b>cable gland</b> , plastic (M 16 x 1.5; with strain relief, exchangeable, max. inner diameter 10.4 mm) <b>or</b> <b>M12 connector</b> (male, 5-pin, A-code) according to DIN EN 61076-2-101
Housing:	plastic, UV-resistant, material polyamide, 30 % glass-globe reinforced, with quick-release screws (slotted / Phillips head combination), colour traffic white (similar to RAL 9016), cover for display is transparent!
Housing dimensions:	72 x 64 x 37.8 mm (Tyr 1 without display) 72 x 64 x 43.3 mm (Tyr 1 with display)
Sensor protection:	sensor sleeve, stainless steel V4A (1.4571), Ø = 6 mm, nominal length NL = 50 mm (optional 30...400 mm)
Sensor cable:	Silicone, SiHF, 2 x 0.25 mm <sup>2</sup> ; KL = 1.5 m (optionally also other lengths and measuring range limits, e.g., PTFE up to +250 °C or glass fibre with steel mesh up to +350 °C)
Ambient temperature:	measuring transducer -30...+70 °C
Permitted humidity:	< 95 % r. H., non-precipitating air
Protection class:	III (according to EN 60 730)
Protection type housing:	<b>IP 65</b> (according to EN 60 529) Housing tested, TÜV SÜD, Report No.713139052 (Tyr 1)
Protection type sensor:	<b>IP 65</b> (according to EN 60 529) <b>sleeve</b> humidity-tight (standard) <b>IP 68</b> (according to EN 60 529) <b>sleeve</b> water-tight (optional) <b>IP 54</b> (according to EN 60 529) with <b>glass fibre</b> cable (optional)
Standards:	CE conformity, electromagnetic compatibility according to EN 61326, according to EMC Directive 2014 / 30 / EU
Optional:	<b>display with illumination</b> , two-line, cut-out approx. 36x15 mm (B x H), to display the <b>actual temperature</b> and <b>internal diagnostics</b> (measuring range exceeded, measuring range not reached, sensor breakage, sensor short circuit)
<b>ACCESSORIES</b>	(see table)

**HFTM**  
with cable gland



**HFTM-Q**  
with M12 connector





Sleeve sensor with temperature measuring transducer, calibratable, with multi-range switching and active output



Dimensional drawing

HFTM

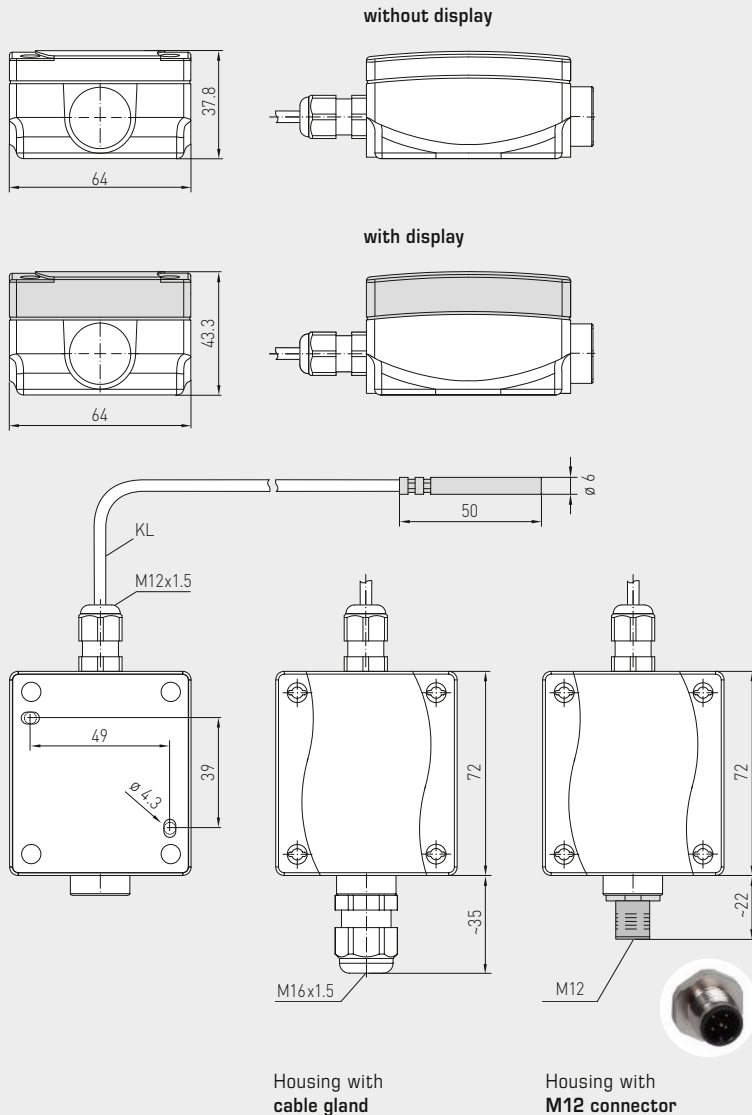

HFTM with cable gland and display



HFTM-Q with M12 connector and display



Display and internal diagnostics  
THERMASGARD®  
Measuring transducer with display



Standard



Measuring range exceeded



Measuring range not reached



Sensor breakage



Sensor short circuit



IP65 (standard)  
humidity-tight



IP68 (optional)  
water-tight  
Perfect Sensor Protection



IP54 (optional)  
with glass fibre cable

High-performance encapsulation against vibration, mechanical stress and humidity



Sleeve sensor with temperature measuring transducer, calibratable, with multi-range switching and active output

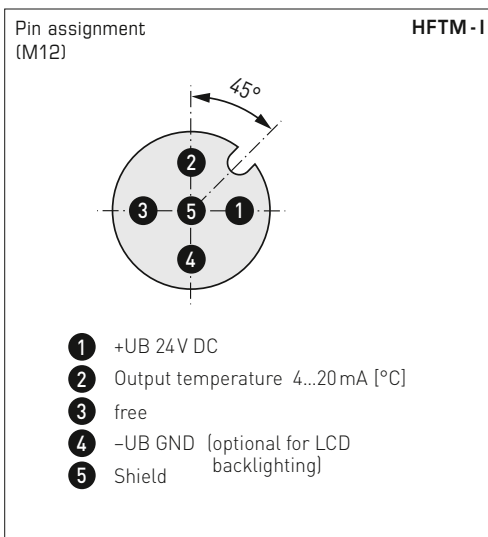
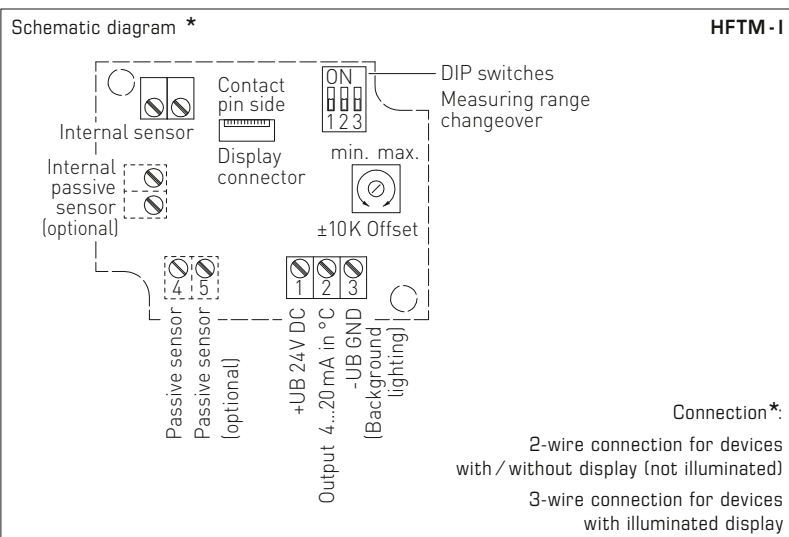
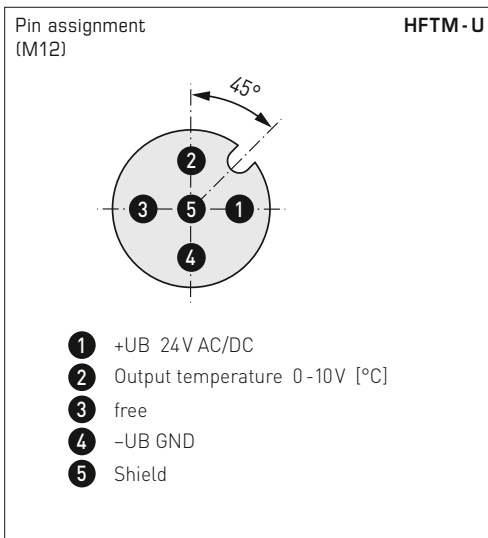
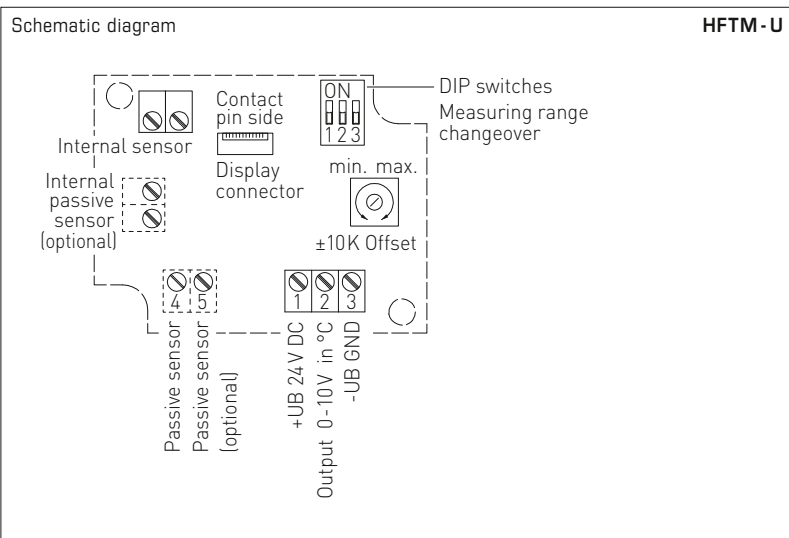

Measuring ranges (adjustable)	DIP 1	DIP 2	DIP 3
-20... +150 °C	ON	ON	ON
-50... +50 °C	OFF	ON	ON
-20... +80 °C	ON	OFF	ON
-30... +60 °C	OFF	OFF	ON
0... +40 °C	ON	ON	OFF
0... +50 °C (default)	OFF	ON	OFF
0... +100 °C	ON	OFF	OFF
0... +150 °C	OFF	OFF	OFF

**HFTM-xx**  
with display, hinged

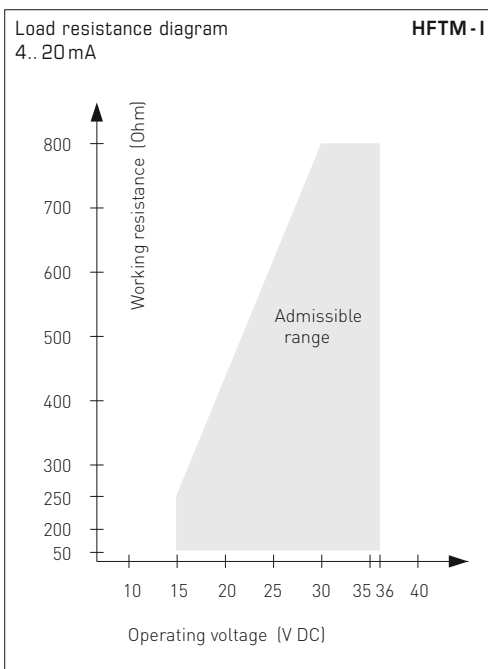



S+S REGELTECHNIK

THERMASGARD® HFTM

Sleeve sensor with temperature measuring transducer,  
calibratable, with multi-range switching and  
active output

HFTM-Q  
with M12 connector

HFTM  
with cable gland

THERMASGARD® HFTM		Sleeve sensor with temperature measuring transducer (with cable gland)				
Type / WG01	Sensor	Output	Type	Display	Item No.	Price
<b>HFTM</b>						
HFTM-I	Pt1000	4...20 mA	Remote sensor		1101-1152-0219-920	99,53 €
HFTM-I LCD	Pt1000	4...20 mA	Remote sensor	■	1101-1152-2219-920	148,05 €
HFTM-U	Pt1000	0-10 V	Remote sensor		1101-1151-0219-920	99,53 €
HFTM-U LCD	Pt1000	0-10 V	Remote sensor	■	1101-1151-2219-920	148,05 €
<b>Housing variant:</b>	Cable connection <b>with cable gland</b>					
Extra charge:	other measuring ranges optional					24,19 €
	Protection type <b>IP68</b> (Sensor sleeve watertight compound-filled)					3,24 €
	2-wire connecting leads, per running meter (silicone/PTFE/glass fibre)					on request
	Other lengths of protection sleeve optional					on request

THERMASGARD® HFTM-Q		Sleeve sensor with temperature measuring transducer (with M12 connector)				
Type / WG01I	Sensor	Output	Type	Display ● = Q	Item No.	Price
<b>HFTM-Q</b>						
HFTM-I Q	Pt1000	4...20 mA	Remote sensor	●	2001-2111-2100-001	139,46 €
HFTM-I Q LCD	Pt1000	4...20 mA	Remote sensor	● ■	2001-2112-2100-001	187,96 €
HFTM-U Q	Pt1000	0-10 V	Remote sensor	●	2001-2111-1100-001	139,46 €
HFTM-U Q LCD	Pt1000	0-10 V	Remote sensor	● ■	2001-2112-1100-001	187,96 €
<b>Housing variant "Q":</b>	Cable connection <b>with M12 connector</b> (male, 5-pin, A-code)					
Extra charge:	see table above!					

ACCESSORIES	
<b>THE-xx</b>	<b>Immersion sleeve</b> , stainless steel <b>V4A</b> (1.4571) or nickel-plated brass, Ø = 9 mm see chapter Accessories!
	<b>Special accessories for M12 connector</b> see chapter Accessories!



**Sleeve sensor with temperature measuring transducer, calibratable, with multi-range switching and active output**

Calibratable temperature measuring transducer with sleeve sensor **THERMASGARD® HFTM - VA** with eight switchable measuring ranges, continuous output, rugged housing made from **stainless steel V4A** with **cable gland** or **M12 connector** according to DIN EN 61076-2-101.

The temperature transmitter with remote sensor is used to detect temperatures in liquid and gaseous media e.g. if installed in an immersion sleeve or as a duct sensor. The measuring transducer is factory-calibrated. Adjustment / fine adjustment by the user is possible (zero point offset is adjustable). A direct, permanent use in liquids is possible in combination with immersion sleeves **THE** (see chapter Accessories).

The sensor is factory-calibrated; an environmental precision adjustment by an expert is possible.

**TECHNICAL DATA**

Power supply:	24 V AC / DC (± 10 %) for U variant 15...36 V DC for I variant, depending on working resistance, residual ripple stabilised ± 0.3 V
Working resistance:	$R_a \text{ (ohm)} = (U_b - 14 \text{ V}) / 0.02 \text{ A}$ for I variant, see working resistance diagram
Load resistance:	$R_L > 5 \text{ kOhm}$ for U variant
Power consumption:	< 1.0 VA / 24 V DC; < 2.2 VA / 24 V AC
Insulating resistance:	≥ 100 MΩ, at +20 °C (500 V DC)
Sensor:	Pt1000, DIN EN 60751, class B <b>(Perfect Sensor Protection with IP68)</b> Sensor external
Measuring ranges:	<b>multi-range switching with 8 switchable measuring ranges,</b> see table (other ranges optional) <b>with manual zero point correction (± 10 K)</b>
Deviation, temperature:	typically ± 0.2 K at +25 °C
Output:	0 - 10 V or 4... 20 mA
Connection type:	2-wire connection
Electrical connection:	0.14 - 1.5 mm <sup>2</sup> , via screw terminals
Cable connection:	<b>cable gland, stainless steel V2A</b> (1.4305) (M20 x 1.5; with strain relief, exchangeable, inner diameter 6 - 12 mm) <b>or</b> <b>M12 connector</b> (male, 5-pin, A-code) according to DIN EN 61076-2-101
Housing:	<b>stainless steel V4A</b> (1.4571), with non-distortion cover bolting, impact-resistant, high EMI shielding, corrosion, temperature, weather- and UV-resistant
Housing dimensions:	143 x 97 x 61 mm (Tyr2E)
Sensor protection:	sensor sleeve, stainless steel V4A (1.4571), Ø = 6 mm, nominal length NL = 50 mm (optional 30...400 mm)
Sensor cable:	Silicone, SiHF, 2 x 0.25 mm <sup>2</sup> ; KL = 1.5 m (optionally also other lengths and measuring range limits, e.g., PTFE up to +250 °C or glass fibre with steel mesh up to +350 °C)
Ambient temperature:	measuring transducer -30...+70 °C
Permitted humidity:	< 95 % r. H., non-precipitating air
Protection class:	III (according to EN 60730)
Protection type housing:	<b>IP 65</b> (according to EN 60529) Housing tested, TÜV SÜD, Report No. 713160960B (Skadi2)
Protection type sensor:	<b>IP 65</b> (according to EN 60529) <b>sleeve</b> humidity-tight (standard) <b>IP 68</b> (according to EN 60529) <b>sleeve</b> water-tight (optional) <b>IP 54</b> (according to EN 60529) with <b>glass fibre</b> cable (optional)
Standards:	CE conformity, electromagnetic compatibility according to EN 61326, according to EMC Directive 2014 / 30 / EU
<b>ACCESSORIES</b>	(see table)



Sleeve sensor with temperature measuring transducer, calibratable, with multi-range switching and active output

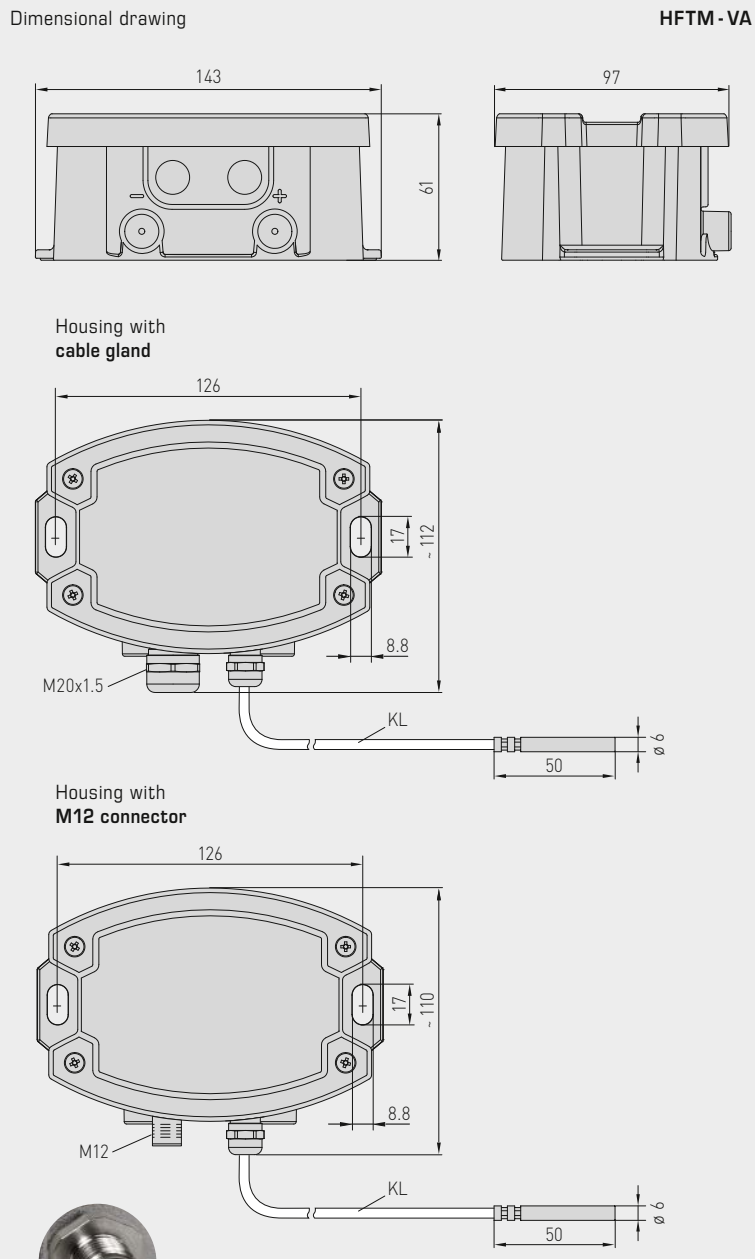

HFTM - VA with cable gland



HFTM - VAQ with M12 connector



M12 connector (male)



IP65 (standard) humidity-tight



IP68 (optional) water-tight Perfect Sensor Protection



IP54 (optional) with glass fibre cable

High-performance encapsulation against vibration, mechanical stress and humidity



Sleeve sensor with temperature measuring transducer, calibratable, with multi-range switching and active output

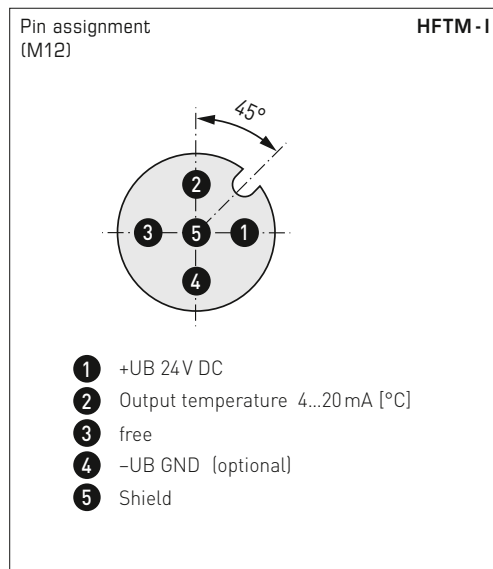
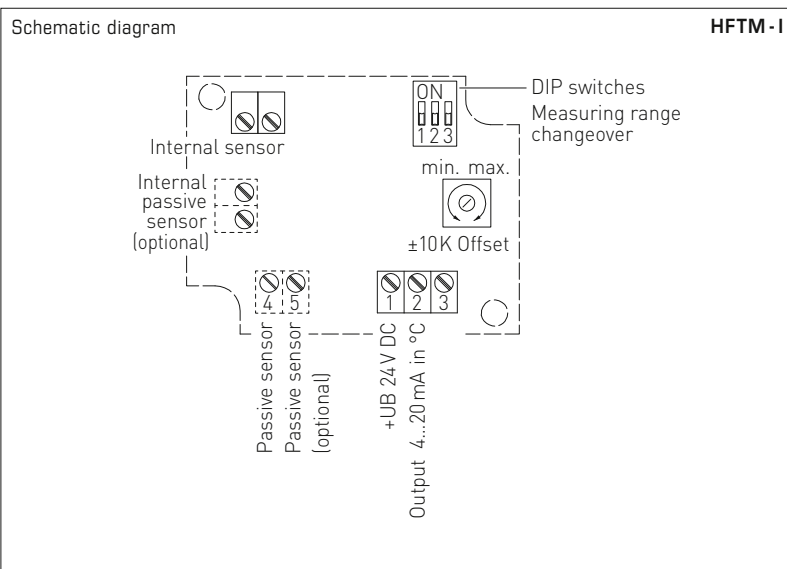
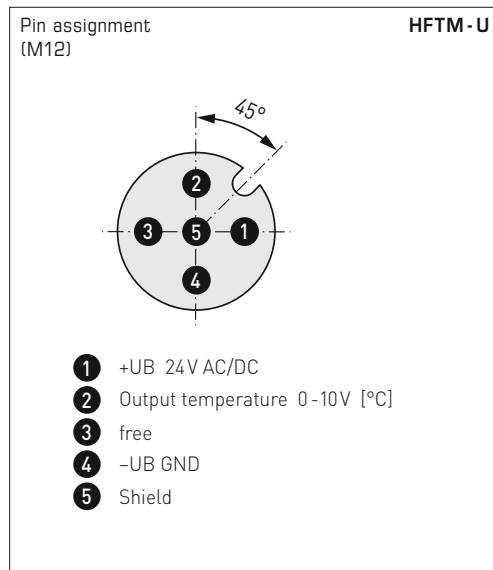
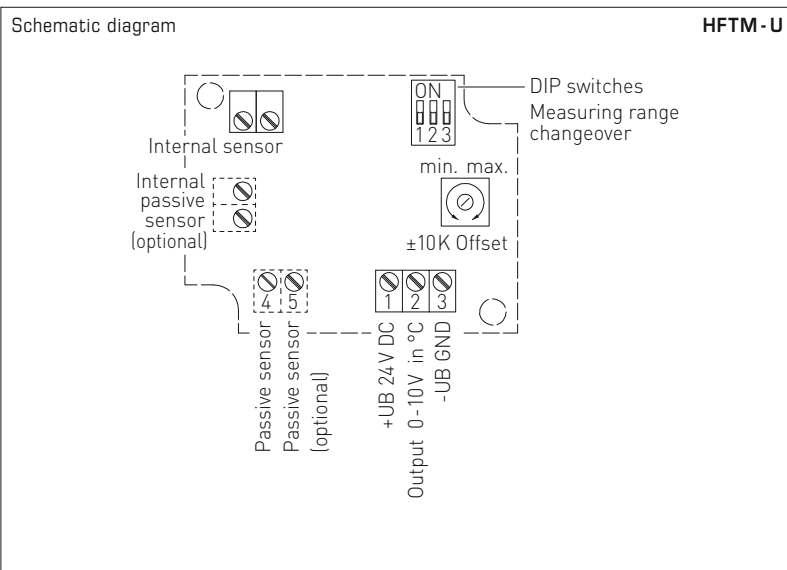

Measuring ranges (adjustable)	DIP 1	DIP 2	DIP 3
-20...+ 150 °C	ON	ON	ON
-50... + 50 °C	OFF	ON	ON
-20... + 80 °C	ON	OFF	ON
-30... + 60 °C	OFF	OFF	ON
0... + 40 °C	ON	ON	OFF
0... + 50 °C (default)	OFF	ON	OFF
0...+ 100 °C	ON	OFF	OFF
0...+ 150 °C	OFF	OFF	OFF

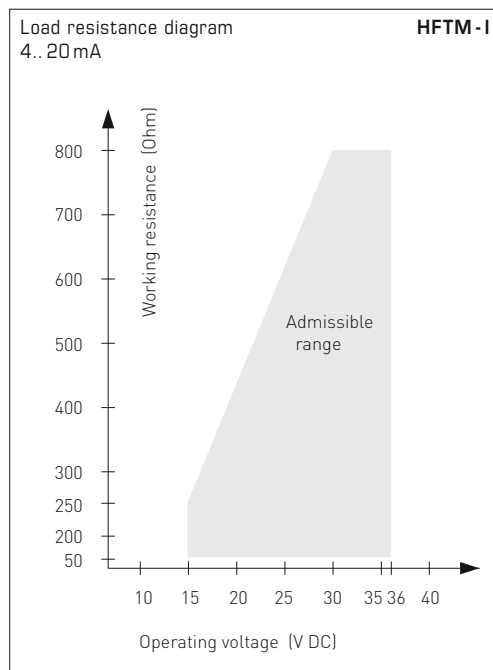



**HFTM - VAQ**  
with M12 connector

**HFTM - VA**  
with cable gland



THERMASGARD® HFTM - VA		Sleeve sensor with temperature measuring transducer, <i>ID</i> (Stainless steel housing with cable gland)			
Type / WG02I	Sensor	Output	Type	Item No.	Price
<b>HFTM - VA</b>					
HFTM-I VA	Pt1000	4...20 mA	Remote sensor	2001-2141-2200-001	<b>365,07 €</b>
HFTM-U VA	Pt1000	0-10 V	Remote sensor	2001-2141-1200-001	<b>365,07 €</b>
<b>Housing variant:</b>	Cable connection with cable gland				
Extra charge:	other measuring ranges optional				<b>24,19 €</b>
	Protection type <b>IP68</b> (Sensor sleeve watertight compound-filled)				<b>3,24 €</b>
	2-wire connecting leads, per running meter (silicone / PTFE / glass fibre)				on request
	Other lengths of protection sleeve optional				on request

THERMASGARD® HFTM - VAQ		Sleeve sensor with temperature measuring transducer, <i>ID</i> (Stainless steel housing with M12 connector)			
Type / WG02I	Sensor	Output	Type	● = Q Item No.	Price
<b>HFTM - VAQ</b>					
HFTM-I VAQ	Pt1000	4...20 mA	Remote sensor	● 2001-2141-2100-001	<b>401,78 €</b>
HFTM-U VAQ	Pt1000	0-10 V	Remote sensor	● 2001-2141-1100-001	<b>401,78 €</b>
<b>Housing variant "Q":</b>	Cable connection with M12 connector (male, 5-pin, A-code)				
Extra charge:	see table above!				

ACCESSORIES	
<b>THE-xx</b>	<b>Immersion sleeve</b> , stainless steel <b>V4A</b> (1.4571) or nickel-plated brass, Ø = 9 mm see chapter Accessories!
	<b>Special accessories for M12 connector</b> see chapter Accessories!

**Surface contact / tube contact temperature measuring transducers, including strap, compact variant, calibratable, with multi-range switching and active output**

ALTM 1

Calibratable surface-contact temperature measuring transducer (compact variant) **THERMASGARD® ALTM 1** with eight switchable measuring ranges, continuous output, in an impact-resistant plastic housing with quick-locking screws, optionally with /without display, incl. strap.

The surface-contact sensor is used to detect the temperature on lines, pipes (e.g., cold and warm water) or on heating sections for heating control. The sensor is factory-calibrated; an environmental precision adjustment by an expert is possible.

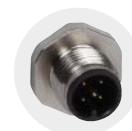

**M12 connector**  
(optional on request)

**TECHNICAL DATA**

Power supply:	24 V AC / DC (± 10%) for U variant 15...36 V DC for I variant, depending on working resistance, residual ripple stabilised ± 0.3 V
Working resistance:	$R_a(\text{ohm}) = (U_b - 14 \text{ V}) / 0.02 \text{ A}$ for I variant
Load resistance:	$R_L > 5 \text{ kOhm}$ for U variant
Power consumption:	< 1.0 VA / 24 V DC; < 2.2 VA / 24 V AC
Sensor:	Pt1000, DIN EN 60751, class B ( <b>Perfect Sensor Protection</b> )
Measuring ranges:	<b>multi-range switching with 8 switchable measuring ranges, see table (other ranges optional)</b> compact variant: $T_{\text{max}}$ up to <b>+100 °C</b> , operating range -50...+100 °C <b>with manual zero point correction (± 10 K)</b>
Deviation, temperature:	typically ± 0.2 K at +25 °C
Output:	0 - 10 V or 4...20 mA
Connection type:	2- or 3-wire connection
Housing:	plastic, UV-resistant, material polyamide, 30% glass-globe reinforced, with quick-locking screws (slotted / Phillips head combination), colour traffic white (similar to RAL 9016), housing cover for display is transparent!
Housing dimensions:	72 x 64 x 37.8 mm (Tyr 1 without display) 72 x 64 x 43.3 mm (Tyr 1 with display)
Cable connection:	<b>cable gland</b> , plastic (M 16 x 1.5; with strain relief, exchangeable, inner diameter 10.4 mm) <b>or</b> <b>M12 connector</b> according to DIN EN 61076-2-101 (optional on request)
Electrical connection:	0.14 - 1.5 mm <sup>2</sup> via terminal screws
Process connection:	endless strap with metal tightener, (included in the scope of delivery) Ø = 13 - 92 mm (1/4 - 3"), length L = 300 mm
Insulating resistance:	≥ 100 MΩ, at +20 °C (500 V DC)
Ambient temperature:	measuring transducer -30...+70 °C
Humidity:	< 95 % r. H., non-precipitating air
Protection class:	III (according to EN 60 730)
Protection type:	<b>IP65</b> (according to EN 60 529) Housing tested, TÜV SÜD, Report No. 713139052 (Tyr 1)
Standards:	CE conformity, electromagnetic compatibility according to EN 61326, according to EMC directive 2014 / 30 / EU
Optional:	Two-line <b>display with illumination</b> , cutout approx. 36 x 15 mm (W x H), for displaying the <b>ACTUAL temperature</b> and the <b>internal diagnostics</b> (measuring range exceeded, measuring range not reached, sensor breakage, sensor short circuit)

Display and internal diagnostics  
**THERMASGARD®**  
**Measuring transducer with display**

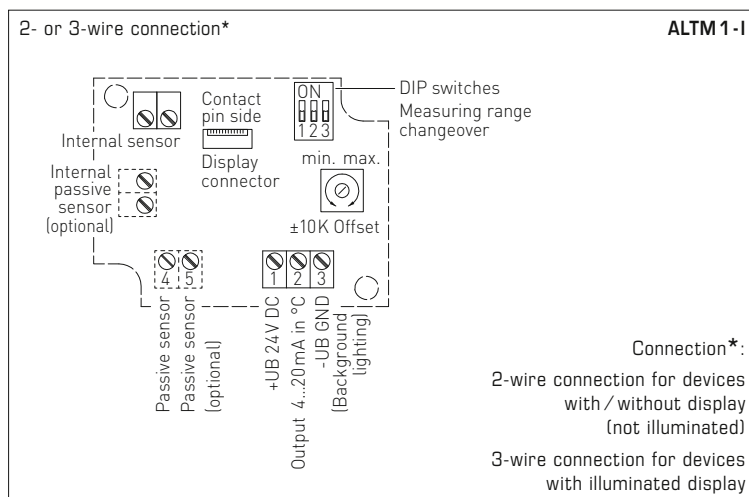
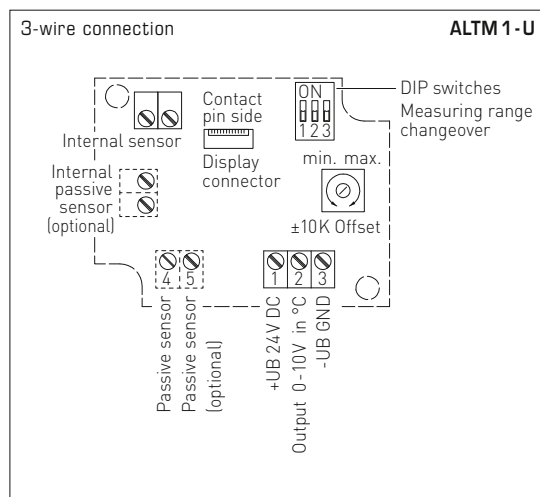
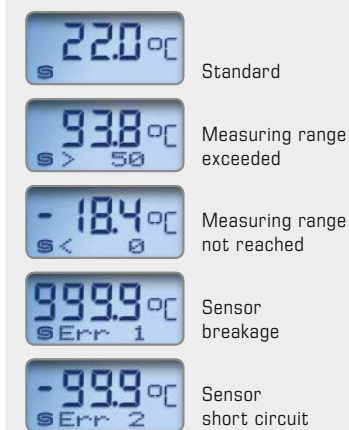





Dimensional drawing

ALTM 1

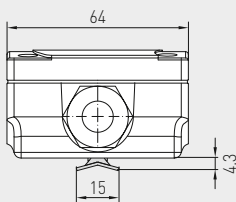
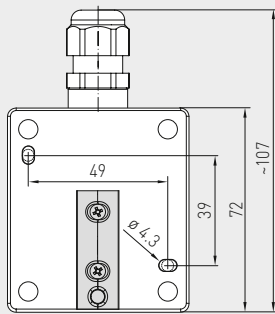

without display

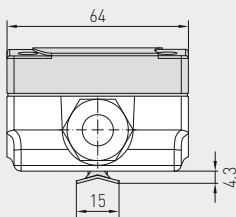
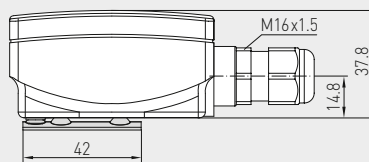

with display

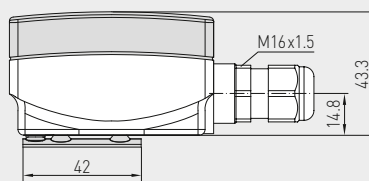

ALTM 1 with display



High-performance encapsulation against vibration, mechanical stress and humidity



Measuring ranges (adjustable)	DIP 1	DIP 2	DIP 3
-20...+150 °C	ON	ON	ON
-50... +50 °C	OFF	ON	ON
-20... +80 °C	ON	OFF	ON
-30... +60 °C	OFF	OFF	ON
0... +40 °C	ON	ON	OFF
0... +50 °C (default)	OFF	ON	OFF
0...+100 °C	ON	OFF	OFF
0...+150 °C	OFF	OFF	OFF

Dependency of output voltage on output current

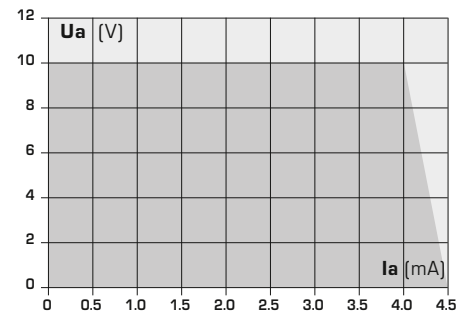

THERMASGARD® ALTM 1 Surface contact / tube contact temperature measuring transducers (compact)						
Type / WG01	Sensor	Output	Type	Display	Item No.	Price
<b>ALTM 1-I</b>					<b>IP65, I-variant</b>	
ALTM1-I	Pt1000	4...20 mA	Compact		1101-1112-0219-920	100,03 €
ALTM1-I LCD	Pt1000	4...20 mA	Compact	■	1101-1112-2219-920	148,53 €
<b>ALTM 1-U</b>					<b>IP65, U-variant</b>	
ALTM1-U	Pt1000	0-10 V	Compact		1101-1111-0219-920	100,03 €
ALTM1-U LCD	Pt1000	0-10 V	Compact	■	1101-1111-2219-920	148,53 €
Extra charge:	Other ranges optional Cable connection with <b>M12 connector</b> according to DIN EN 61076-2-101					24,19 € on request

ACCESSORIES			
WLP-1	Heat-conductive paste, silicone-free	7100-0060-1000-000	3,22 €

**Surface contact / tube contact temperature measuring transducers, incl. strap, with detached sensor head, calibratable, with multi-range switching and active output**

Calibratable tube contact temperature measuring transducer **THERMASGARD® ALTM 2** with eight switchable, measuring ranges, external sensor, continuous output, housing made from impact-resistant plastic with quick-release screws, optionally **with/without display**, with **cable gland** or **M12 connector** according to DIN EN 61076-2-101.

The surface-contact sensor is used for temperature detection on lines, pipes (e.g. cold and hot water) or on heating sections for heating system control.

The sensor is factory-calibrated; an environmental precision adjustment by an expert is possible.

**ALTM 2**  
with cable gland



**ALTM 2-Q**  
with M12 connector



**TECHNICAL DATA**

Power supply:	24 V AC / DC (± 10%) for U variant 15...36 V DC for I variant, depending on working resistance, residual ripple stabilised ± 0.3 V
Working resistance:	$R_a \text{ (ohm)} = (U_b - 14 \text{ V}) / 0.02 \text{ A}$ for I variant, see working resistance diagram
Load resistance:	$R_L > 5 \text{ kOhm}$ for U variant
Power consumption:	< 1.0 VA / 24 V DC; < 2.2 VA / 24 V AC
Insulating resistance:	≥ 100 MΩ, at +20 °C (500 V DC)
Sensor:	Pt1000, DIN EN 60751, class B <b>(Perfect Sensor Protection at IP68)</b> sensor external
Measuring ranges:	<b>multi-range switching</b> <b>with 8 switchable measuring ranges</b> see table (other measuring ranges optional) <b>T<sub>max</sub> above +100 °C</b> , operating range -50...+150 °C <b>with manual zero point correction (± 10 K)</b>
Deviation in temperature:	typically ± 0.2 K at +25 °C
Output:	0 - 10 V or 4...20 mA
Connection type:	2- or 3-wire connection
Cable connection:	<b>cable gland</b> , plastic (M 16 x 1.5; with strain relief, exchangeable, max. inner diameter 10.4 mm) <b>or</b> <b>M12 connector</b> (male, 5-pin, A-code) according to DIN EN 61076-2-101
Housing:	plastic, UV-resistant, material polyamide, 30% glass-globe reinforced, with quick-release screws (slotted / Phillips head combination), colour traffic white (similar to RAL 9016), cover for display is transparent!
Housing dimensions:	72 x 64 x 37.8 mm (Tyr 1 without display) 72 x 64 x 43.3 mm (Tyr 1 with display)
Sensor cable:	Silicone, SiHF, 2 x 0.25 mm <sup>2</sup> ; KL = 1.5 m (optionally also other lengths and measuring range limits, e.g., PTFE up to +250 °C or glass fibre with steel mesh up to +350 °C)
Sensor protection:	pipe feeder made of stainless steel <b>V4A</b> (1.4571), Ø = 6 mm, L = 50 mm
Electrical connection:	0.14 - 1.5 mm <sup>2</sup> , via screw terminals
Process connection:	endless strap with metal tightener (included in the scope of delivery) Ø = 13 - 92 mm (1/4 - 3"), L = 300 mm
Ambient temperature:	measuring transducer -30...+70 °C
Permitted humidity:	< 95% r. H., non-precipitating air
Protection class:	III (according to EN 60730)
Protection type housing:	<b>IP 65</b> (according to EN 60529) Housing tested, TÜV SÜD, Report No.713139052 (Tyr 1)
Protection type sensor:	<b>IP 65</b> (according to EN 60529) <b>sleeve</b> humidity-tight (standard) <b>IP 68</b> (according to EN 60529) <b>sleeve</b> water-tight (optional)
Standards:	CE conformity, electromagnetic compatibility according to EN 61326, according to EMC Directive 2014 / 30 / EU
Optional:	<b>display with illumination</b> , two-line, cut-out approx. 36x15 mm (B x H), to display the <b>actual temperature</b> and <b>internal diagnostics</b> (measuring range exceeded, measuring range not reached, sensor breakage, sensor short circuit)
<b>ACCESSORIES</b>	(see table)



Surface contact / tube contact temperature measuring transducers, incl. strap, with detached sensor head, calibratable, with multi-range switching and active output



Dimensional drawing

ALTM 2

without display

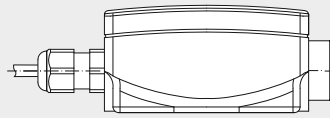
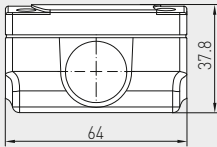

with display

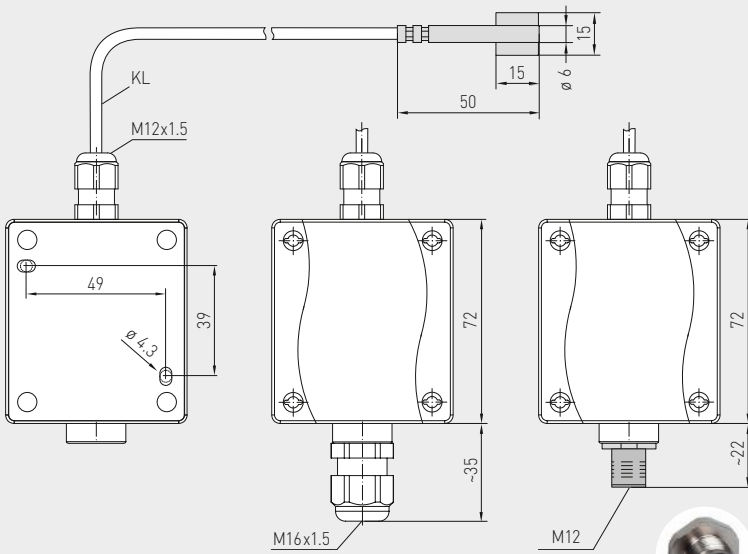
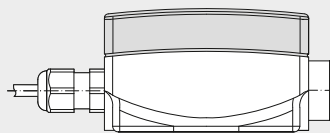
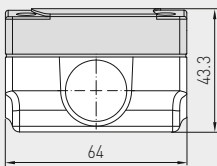

Housing with cable gland

Housing with M12 connector

ALTM 2 with cable gland and display



ALTM 2-Q with M12 connector and display



Display and internal diagnostics  
THERMASGARD®  
Measuring transducer with display



Standard



Measuring range exceeded



Measuring range not reached



Sensor breakage



Sensor short circuit



IP65 (standard)  
humidity-tight



IP68 (optional)  
water-tight  
Perfect Sensor Protection

\* High-performance encapsulation against vibration, mechanical stress and humidity



Surface contact / tube contact temperature measuring transducers,  
incl. strap, with detached sensor head, calibratable,  
with multi-range switching and active output

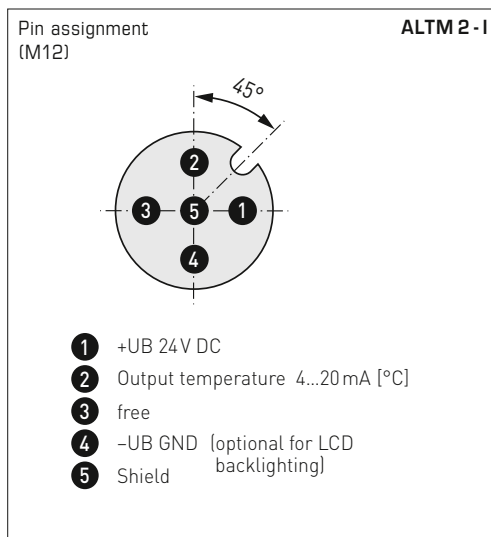
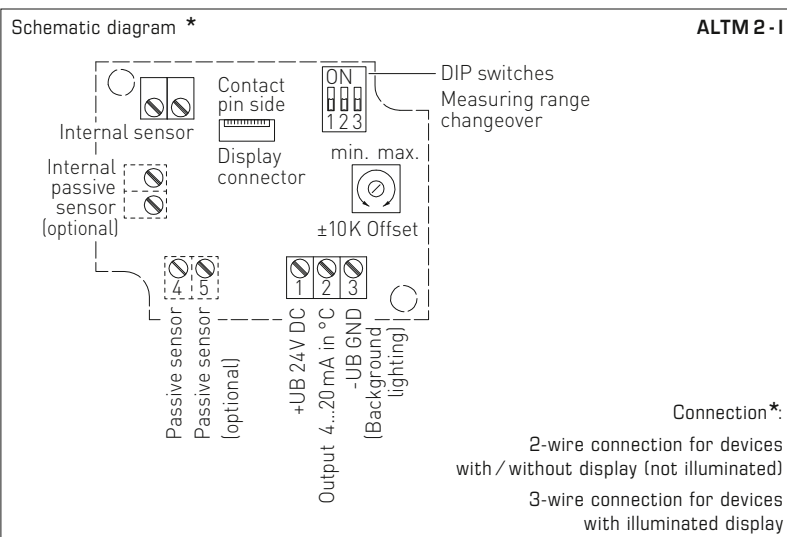
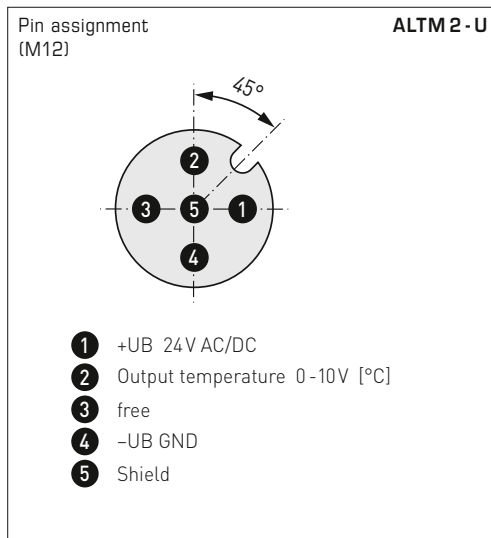
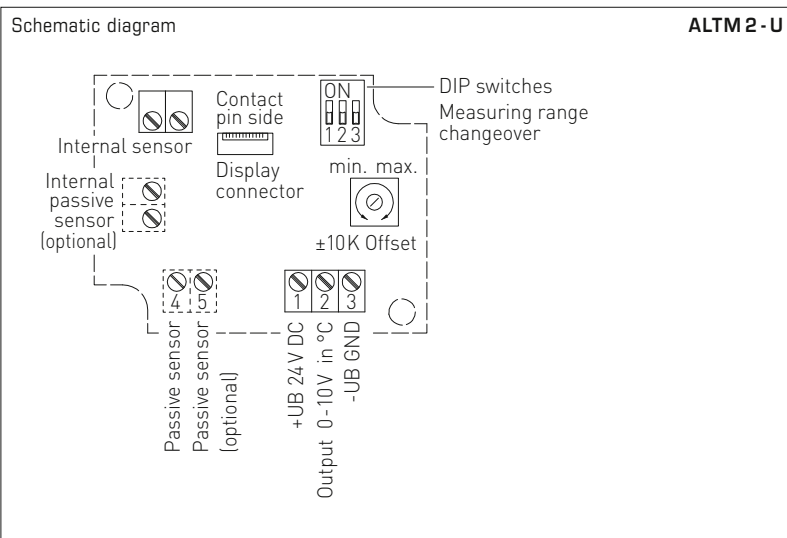

Measuring ranges (adjustable)	DIP 1	DIP 2	DIP 3
-20... +150 °C	ON	ON	ON
-50... +50 °C	OFF	ON	ON
-20... +80 °C	ON	OFF	ON
-30... +60 °C	OFF	OFF	ON
0... +40 °C	ON	ON	OFF
0... +50 °C (default)	OFF	ON	OFF
0... +100 °C	ON	OFF	OFF
0... +150 °C	OFF	OFF	OFF

**ALTM 2-xx**  
with display,  
hinged

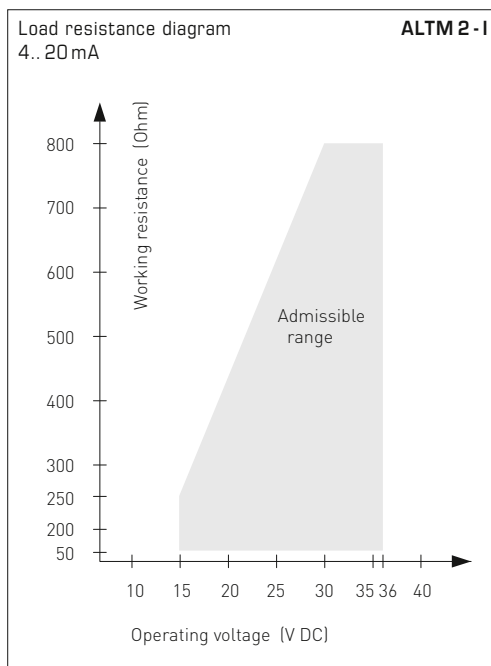



S+S REGELTECHNIK

THERMASGARD® ALTM 2

Surface contact / tube contact temperature measuring transducers,  
incl. strap, with detached sensor head, calibratable,  
with multi-range switching and active output

ALTM 2 - Q  
with M12 connector



ALTM 2  
with cable gland

THERMASGARD® ALTM 2		Surface contact / tube contact temperature measuring transducers (with cable gland)				
Type / WG01	Sensor	Output	Type	Display	Item No.	Price
<b>ALTM 2</b>						
ALTM2-I	Pt1000	4...20 mA	Remote sensor		1101-1122-0219-920	106,69 €
ALTM2-I LCD	Pt1000	4...20 mA	Remote sensor	■	1101-1122-2219-920	155,20 €
ALTM2-U	Pt1000	0-10 V	Remote sensor		1101-1121-0219-920	106,69 €
ALTM2-U LCD	Pt1000	0-10 V	Remote sensor	■	1101-1121-2219-920	155,20 €
<b>Housing variant:</b>	Cable connection <b>with cable gland</b>					
Extra charge:	other measuring ranges optional					24,19 €
	Protection type <b>IP68</b> (Sensor sleeve watertight compound-filled)					3,24 €
	2-wire connecting leads, per running meter (silicone / PTFE / glass fibre)					on request

THERMASGARD® ALTM 2 - Q		Surface contact / tube contact temperature measuring transducers (with M12 connector)				
Type / WG011	Sensor	Output	Type	Display ● = Q	Item No.	Price
<b>ALTM 2 - Q</b>						
ALTM2-I Q	Pt1000	4...20 mA	Remote sensor	●	2001-2121-2100-001	146,62 €
ALTM2-I Q LCD	Pt1000	4...20 mA	Remote sensor	● ■	2001-2122-2100-001	195,11 €
ALTM2-U Q	Pt1000	0-10 V	Remote sensor	●	2001-2121-1100-001	146,62 €
ALTM2-U Q LCD	Pt1000	0-10 V	Remote sensor	● ■	2001-2122-1100-001	195,11 €
<b>Housing variant "Q":</b>	Cable connection <b>with M12 connector</b> (male, 5-pin, A-code)					
Extra charge:	see table above!					

ACCESSORIES			
WLP-1	Heat-conductive paste, silicone-free	7100-0060-1000-000	3,22 €
<b>Special accessories for M12 connector</b> see chapter Accessories!			



Surface contact / tube contact temperature measuring transducers,  
incl. strap, with detached sensor head, calibratable,  
with multi-range switching and active output

Calibratable tube contact temperature measuring transducer **THERMASGARD® ALTM 2 - VA** with eight switchable measuring ranges, external sensor, continuous output, rugged housing made from **stainless steel V4A**, with **cable gland** or **M12 connector** according to DIN EN 61076-2-101.

The surface-contact sensor is used for temperature detection on lines, pipes (e.g. cold and hot water) or on heating sections for heating system control.

The sensor is factory-calibrated; an environmental precision adjustment by an expert is possible.

#### TECHNICAL DATA

Power supply:	24 V AC / DC (± 10 %) for U variant 15...36 V DC for I variant, depending on working resistance, residual ripple stabilised ± 0.3 V
Working resistance:	$R_a(\text{ohm}) = (U_b - 14 \text{ V}) / 0.02 \text{ A}$ for I variant, see working resistance diagram
Load resistance:	$R_L > 5 \text{ kOhm}$ for U variant
Power consumption:	< 1.0 VA / 24 V DC; < 2.2 VA / 24 V AC
Insulating resistance:	≥ 100 MΩ, at +20 °C (500 V DC)
Sensor:	Pt1000, DIN EN 60751, class B <b>(Perfect Sensor Protection with IP68)</b> Sensor external
Measuring ranges:	<b>multi-range switching</b> <b>with 8 switchable measuring ranges</b> see table (other ranges optional) <b>T<sub>max</sub> above +100 °C</b> , operating range -50...+150 °C <b>with manual zero point correction (± 10 K)</b>
Deviation, temperature:	typically ± 0.2 K at +25 °C
Output:	0 - 10 V or 4...20 mA
Connection type:	2-wire connection
Cable connection:	<b>cable gland, stainless steel V2A</b> (1.4305) (M20 x 1.5; with strain relief, exchangeable, inner diameter 6 - 12 mm) <b>or</b> <b>M12 connector</b> (male, 5-pin, A-code) according to DIN EN 61076-2-101
Housing:	<b>stainless steel V4A</b> (1.4571), with non-distortion cover bolting, impact-resistant, high EMI shielding, corrosion, temperature, weather- and UV-resistant
Housing dimensions:	143 x 97 x 61 mm (Tyr 2E)
Sensor cable:	Silicone, SiHF, 2 x 0.25 mm <sup>2</sup> ; KL = 1.5 m (optionally also other lengths and measuring range limits, e.g., PTFE up to +250 °C or glass fibre with steel mesh up to +350 °C)
Sensor protection:	pipe feeder, made of stainless steel <b>V4A</b> (1.4571), Ø = 6 mm, L = 50 mm
Electrical connection:	0.14 - 1.5 mm <sup>2</sup> , via screw terminals
Process connection:	endless strap with metal tightener (included in the scope of delivery) Ø = 13 - 92 mm (1/4 - 3"), L = 300 mm
Ambient temperature:	measuring transducer -30...+70 °C
Permitted humidity:	< 95 % r. H., non-precipitating air
Protection class:	III (according to EN 60 730)
Protection type housing:	<b>IP 65</b> (according to EN 60 529) Housing tested, TÜV SÜD, Report No. 713160960B (Skadi2)
Protection type sensor:	<b>IP 65</b> (according to EN 60 529) <b>sleeve</b> humidity-tight (standard) <b>IP 68</b> (according to EN 60 529) <b>sleeve</b> water-tight (optional)
Standards:	CE conformity, electromagnetic compatibility according to EN 61326, according to EMC Directive 2014 / 30 / EU
<b>ACCESSORIES</b>	(see table)



Surface contact / tube contact temperature measuring transducers, incl. strap, with detached sensor head, calibratable, with multi-range switching and active output

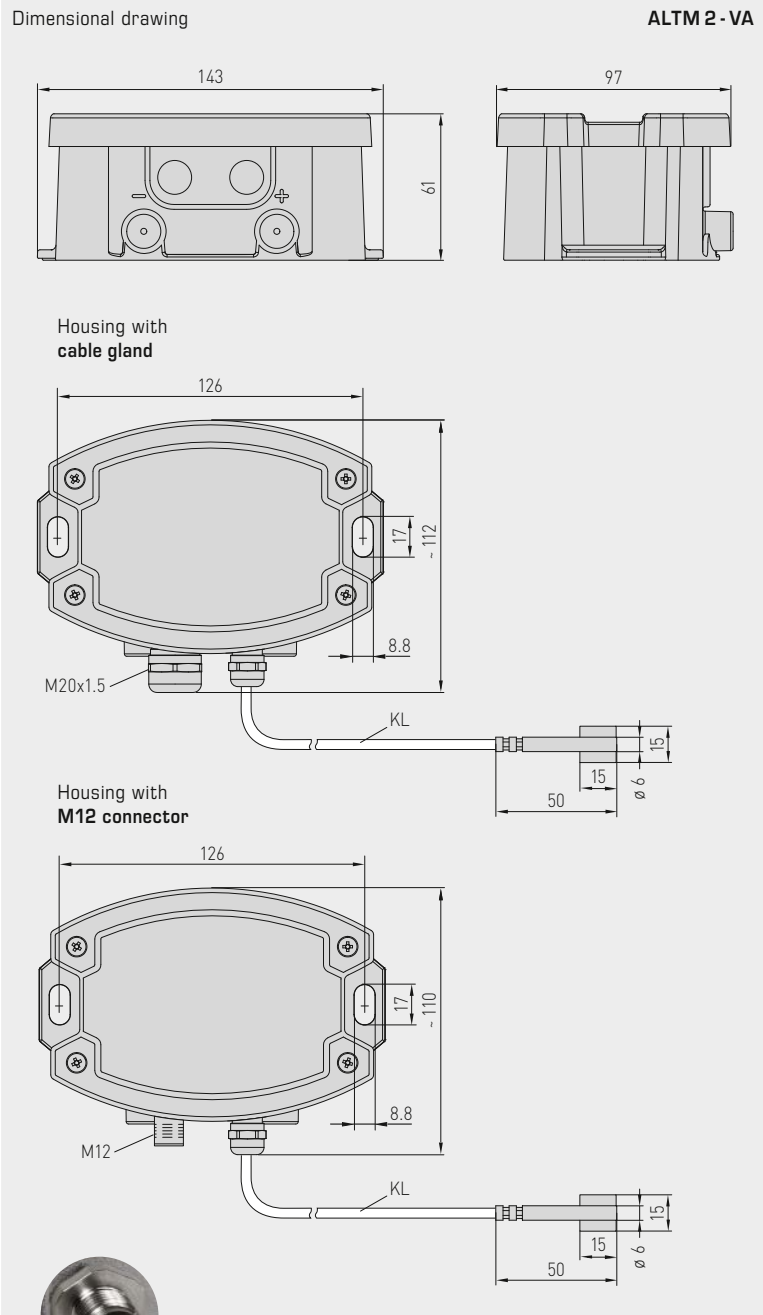

**ALTM 2 - VA**  
with cable gland



**ALTM 2 - VAQ**  
with M12 connector



M12 connector  
(male)



**IP65** (standard)  
humidity-tight



**IP68** (optional)  
water-tight  
**Perfect Sensor Protection**

High-performance encapsulation against vibration, mechanical stress and humidity



Surface contact / tube contact temperature measuring transducers, incl. strap, with detached sensor head, calibratable, with multi-range switching and active output

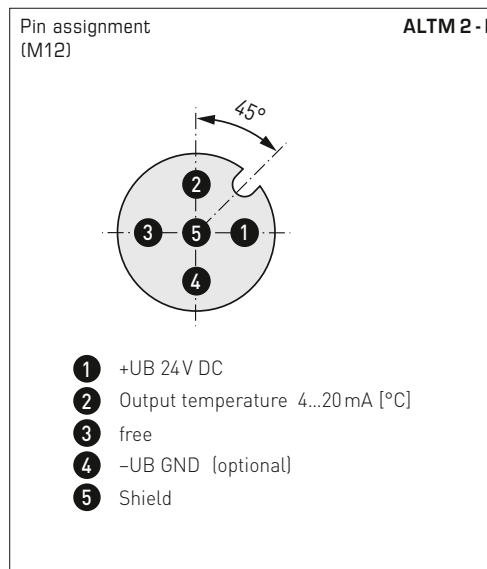
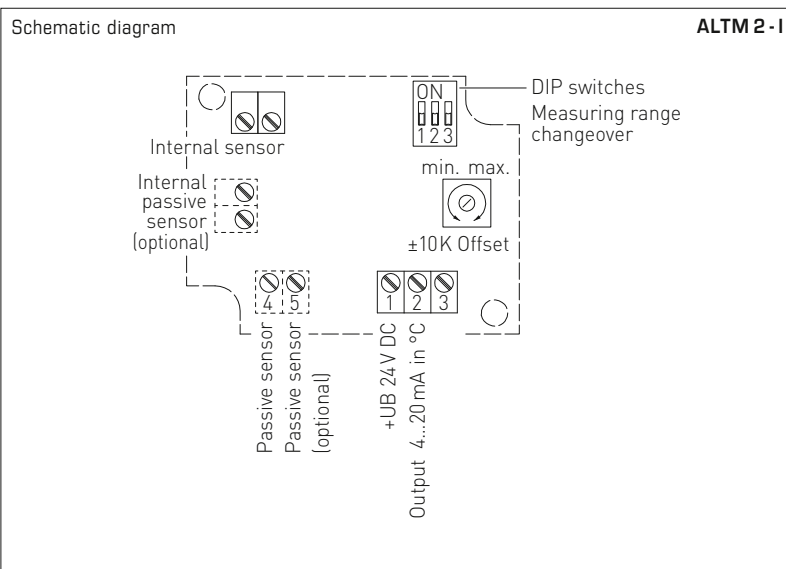
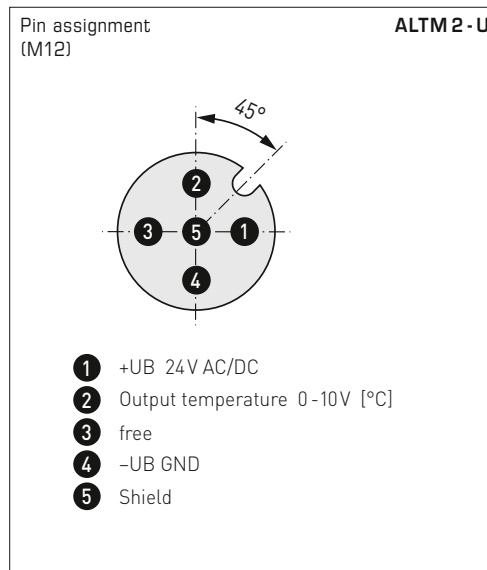
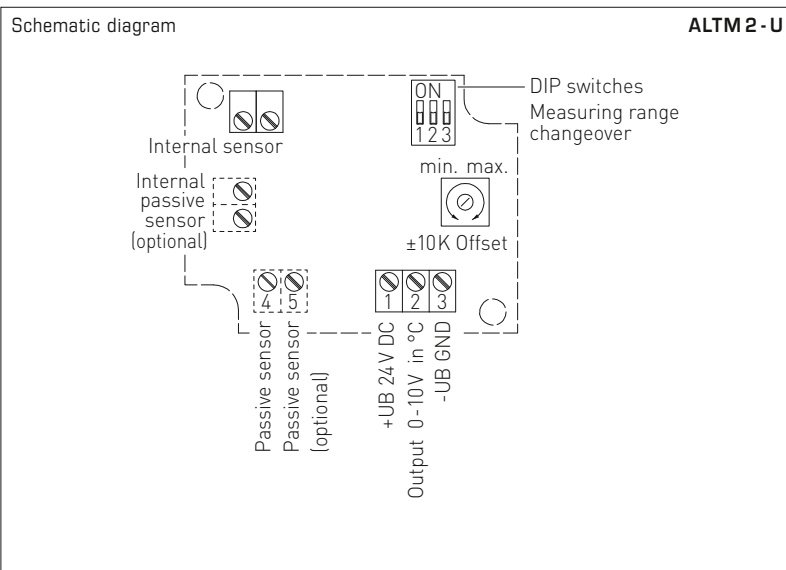

Measuring ranges (adjustable)	DIP 1	DIP 2	DIP 3
-20...+ 150 °C	ON	ON	ON
-50... +50 °C	OFF	ON	ON
-20... +80 °C	ON	OFF	ON
-30... +60 °C	OFF	OFF	ON
0... +40 °C	ON	ON	OFF
0... +50 °C (default)	OFF	ON	OFF
0...+ 100 °C	ON	OFF	OFF
0...+ 150 °C	OFF	OFF	OFF

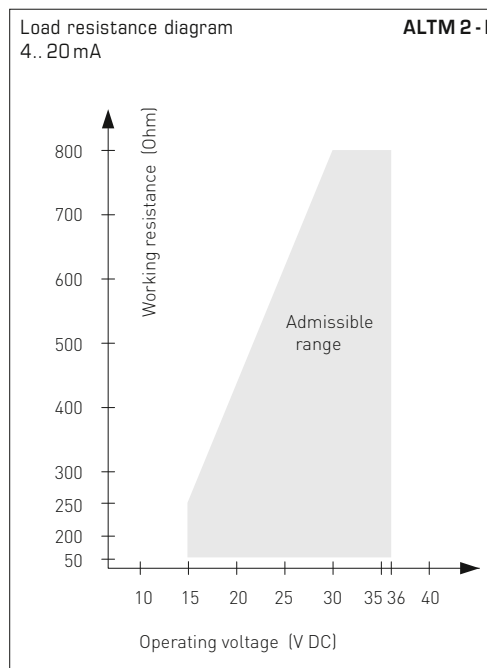



Surface contact / tube contact temperature measuring transducers,  
incl. strap, with detached sensor head, calibratable,  
with multi-range switching and active output

**ALTM 2 - VAQ**  
with M12 connector

**ALTM 2 - VA**  
with cable gland



THERMASGARD® ALTM 2 - VA		Surface contact / tube contact temperature measuring transducers, <i>ID</i> (Stainless steel housing with cable gland)			
Type / WG02I	Sensor	Output	Type	Item No.	Price
<b>ALTM 2 - VA</b>					
ALTM2-I VA	Pt1000	4...20 mA	Remote sensor	2001-2151-2200-001	<b>375,82 €</b>
ALTM2-U VA	Pt1000	0-10 V	Remote sensor	2001-2151-1200-001	<b>375,82 €</b>
<b>Housing variant:</b>	Cable connection with cable gland				
Extra charge:	other measuring ranges optional Protection type <b>IP68</b> (Sensor sleeve watertight compound-filled) 2-wire connecting leads, per running meter (silicone / PTFE / glass fibre)				<b>24,19 €</b> <b>3,24 €</b> on request

THERMASGARD® ALTM 2 - VAQ		Surface contact / tube contact temperature measuring transducers, <i>ID</i> (Stainless steel housing with M12 connector)				
Type / WG02I	Sensor	Output	Type	● = Q	Item No.	Price
<b>ALTM 2 - VAQ</b>						
ALTM2-I VAQ	Pt1000	4...20 mA	Remote sensor	●	2001-2151-2100-001	<b>412,52 €</b>
ALTM2-U VAQ	Pt1000	0-10 V	Remote sensor	●	2001-2151-1100-001	<b>195,11 €</b>
<b>Housing variant "Q":</b>	Cable connection with M12 connector (male, 5-pin, A-code)					
Extra charge:	see table above!					

ACCESSORIES	
Special accessories for M12 connector see chapter Accessories!	



**Pendulum room temperature measuring transducers, calibratable, with multi-range switching and active output**

Calibratable room pendulum temperature measuring transducer (with sleeve) **THERMASGARD® RPTM 1** with eight switchable measuring ranges, continuous output, in an impact-resistant plastic housing with quick-locking screws, optionally with/without display, cable sensor with stainless steel sleeve and plastic sinter filter (exchangeable).

The pendulum sensor has been specially designed to detect the temperature in larger rooms or halls. The resistance thermometer achieves a very good representative measurement result due to its positioning in the room. The sensor is factory-calibrated; an environmental precision adjustment by an expert is possible.

RPTM 1



**TECHNICAL DATA**

Power supply:	24 V AC / DC (± 10%) for U variant 15...36 V DC for I variant, depending on working resistance, residual ripple stabilised ± 0.3 V
Working resistance:	$R_a(\text{ohm}) = (U_b - 14 \text{ V}) / 0.02 \text{ A}$ for I variant
Load resistance:	$R_L > 5 \text{ kOhm}$ for U variant
Power consumption:	< 1.0 VA / 24 V DC; < 2.2 VA / 24 V AC
Sensor:	Pt1000, DIN EN 60751, class B
Sensor protection:	<b>plastic</b> sinter filter, Ø 16 mm, L = 35 mm, exchangeable (optional <b>metal</b> sinter filter, Ø 16 mm, L = 32 mm)
Measuring ranges:	<b>multi-range switching with 8 switchable measuring ranges</b> see table (other ranges optional) <b>T<sub>min</sub> -5 °C, T<sub>max</sub> +60 °C, with manual zero point correction (± 10 K)</b>
Deviation, temperature:	typically ± 0.2 K at +25 °C
Output:	0 - 10 V or 4...20 mA
Ambient temperature:	measuring transducer -5...+60 °C
Connection type:	2- or 3-wire connection
Housing:	plastic, UV-resistant, material polyamide, 30% glass-globe reinforced, with quick-locking screws (slotted / Phillips head combination), colour traffic white (similar to RAL 9016), housing cover for display is transparent!
Housing dimensions:	72 x 64 x 37.8 mm (Tyr 1 without display) 72 x 64 x 43.3 mm (Tyr 1 with display)
Cable connection:	<b>cable gland</b> , plastic (M 16 x 1.5; with strain relief, exchangeable, max. inner diameter 10.4 mm) or <b>M12 connector</b> according to DIN EN 61076-2-101 (on request)
Electrical connection:	0.14 - 1.5 mm <sup>2</sup> , via terminal screws
Connection cable:	PVC, H03VV-F, 2 x 0.5 mm <sup>2</sup> , KL = approx. 1.5 m (other lengths optional)
Protective tube:	<b>stainless steel V2A</b> (1.4301), Ø = 16 mm, NL = 142 mm
Humidity:	< 95% r. H., non-precipitating air
Protection class:	III (according to EN 60730)
Protection type:	<b>IP 67</b> (according to EN 60529) Housing tested, TÜV SÜD, Report No. 713139052 (Tyr 1) <b>IP 65</b> (according to EN 60529) Pendulum with sleeve
Standards:	CE conformity, electromagnetic compatibility according to EN 61326, according to EMC directive 2014 / 30 / EU
Optional:	Two-line <b>display with illumination</b> , cutout approx. 36 x 15 mm (W x H), for displaying the <b>ACTUAL temperature</b> and the <b>internal diagnostics</b> (measuring range exceeded, measuring range not reached, sensor breakage, sensor short circuit)

Display and internal diagnostics  
**THERMASGARD®**  
Measuring transducer with display

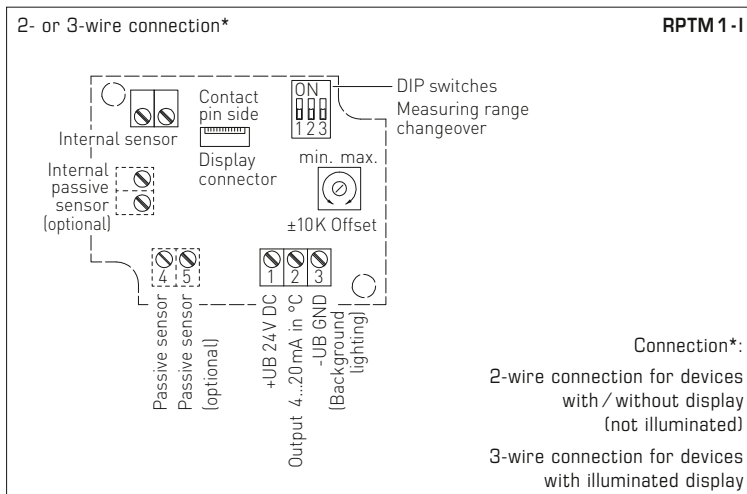
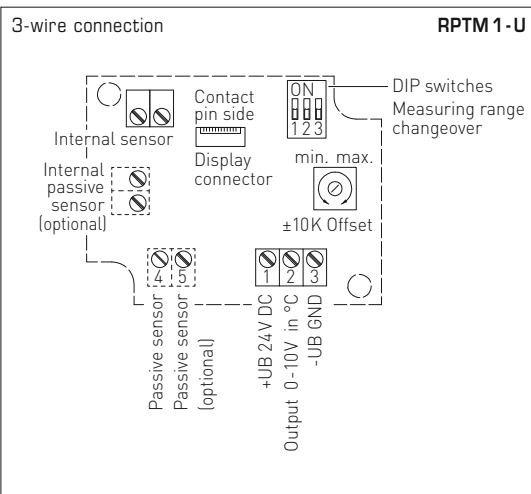
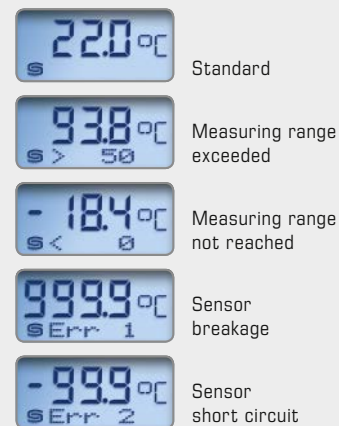





S+S REGELTECHNIK

THERMASGARD® RPTM 1

Pendulum room temperature measuring transducers, calibratable, with multi-range switching and active output

Dimensional drawing

RPTM 1

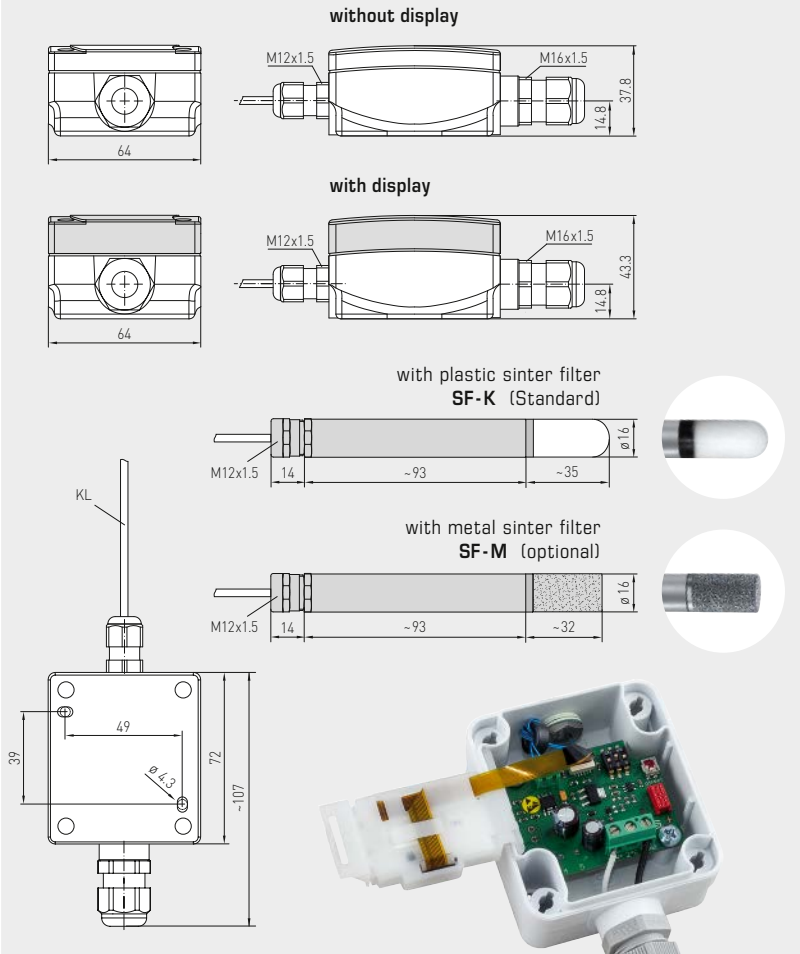

RPTM 1 with display

M12 connector (optional on request)



Measuring ranges [adjustable]	DIP 1	DIP 2	DIP 3
-20...+150 °C	ON	ON	ON
-50... +50 °C	OFF	ON	ON
-20... +80 °C	ON	OFF	ON
-30... +60 °C	OFF	OFF	ON
0... +40 °C	ON	ON	OFF
0... +50 °C (default)	OFF	ON	OFF
0...+100 °C	ON	OFF	OFF
0...+150 °C	OFF	OFF	OFF

[observe max. permissible temperature ranges!]

Dependency of output voltage on output current

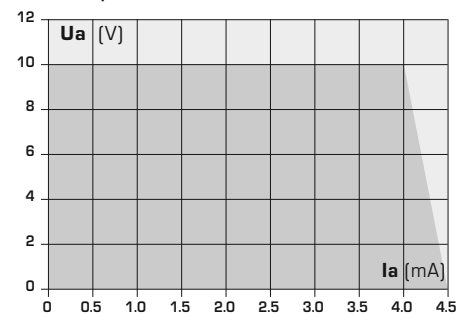

THERMASGARD® RPTM 1 Pendulum room temperature measuring transducer (with stainless steel sleeve)					
Type / WG01	Sensor	Output	Type	Item No.	Price
<b>RPTM 1-I</b>					
RPTM1-I	Pt1000	4...20 mA	Remote sensor	IP65, I-variant 1101-1162-0219-910	144,53 €
<b>RPTM 1-U</b>					
RPTM1-U	Pt1000	0-10 V	Remote sensor	IP65, U-variant 1101-1161-0219-910	144,53 €
Extra charge:	Other ranges optional				24,19 €
	Two-line display with illumination				47,46 €
	2-wire connecting leads, per running meter (PVC)				on request
	Cable connection with M12 connector according to DIN EN 61076-2-101				on request
<b>ACCESSOIRES</b>					
SF-M	Metal sinter filter, Ø 16 mm, L = 32 mm, exchangeable, stainless steel V4A (1.4404)			7000-0050-2200-100	40,31 €

**Pendulum room temperature measuring transducers, calibratable, with multi-range switching and active output**

RPTM 2

Calibratable room pendulum temperature measuring transducer (with globe) **THERMASGARD® RPTM 2** with eight switchable measuring ranges, continuous output in an impact-resistant plastic housing with quick-locking screws, optionally with/without display, cable sensor with a black plastic globe.

The pendulum sensor has been specially designed to detect the temperature in larger rooms or halls. The resistance thermometer (globe thermometer) achieves a very good, representative measurement result due to its positioning in the room. The dark radiation sensor determines the effective radiation heat at the measured location. This is relevant for calculating the thermal comfort (operative room temperature) taking into account the co-action of thermal radiation and thermal convection. The ratio of globe temperature / air temperature is approx. 70% / 30%. The sensor is factory-calibrated; an environmental precision adjustment by an expert is possible.



**TECHNICAL DATA**

Power supply:	24 V AC / DC (± 10 %) for U variant 15...36 V DC for I variant, depending on working resistance, residual ripple stabilised ± 0.3 V
Working resistance:	$R_a \text{ (ohm)} = (U_b - 14 \text{ V}) / 0.02 \text{ A}$ for I variant
Load resistance:	$R_L > 5 \text{ kOhm}$ for U variant
Power consumption:	< 1.0 VA / 24 V DC; < 2.2 VA / 24 V AC
Sensor:	Pt1000, DIN EN 60751, class B
Measuring ranges:	<b>multi-range switching with 8 switchable measuring ranges</b> see table (other ranges optional) <b>T<sub>min</sub> -5 °C, T<sub>max</sub> +60 °C, with manual zero point correction (± 10 K)</b>
Deviation, temperature:	typically ± 0.2 K at +25 °C
Output:	0 - 10 V or 4...20 mA
Ambient temperature:	measuring transducer -5...+60 °C
Connection type:	2- or 3-wire connection
Housing:	plastic, UV-resistant, material polyamide, 30 % glass-globe reinforced, with quick-locking screws (slotted / Phillips head combination), colour traffic white (similar to RAL 9016), housing cover for display is transparent!
Housing dimensions:	72 x 64 x 37.8 mm (Tyr 1 without display) 72 x 64 x 43.3 mm (Tyr 1 with display)
Cable connection:	<b>cable gland</b> , plastic (M 16 x 1.5; with strain relief, exchangeable, max. inner diameter 10.4 mm) <b>or</b> <b>M12 connector</b> according to DIN EN 61076-2-101 (on request)
Electrical connection:	0.14 - 1.5 mm <sup>2</sup> , via terminal screws
Connection cable:	PVC, H03VV-F, 2 x 0.5 mm <sup>2</sup> , KL = approx. 1.5 m (other lengths optional)
Globe:	plastic, colour black, Ø = 50 mm
Humidity:	< 95 % r. H., non-precipitating air
Protection class:	III (according to EN 60 730)
Protection type:	<b>IP 67</b> (according to EN 60 529) Housing tested, TÜV SÜD, Report No. 713139052 (Tyr 1) <b>IP 65</b> (according to EN 60 529) Pendulum with globe
Standards:	CE conformity, electromagnetic compatibility according to EN 61326, according to EMC directive 2014 / 30 / EU
Optional:	Two-line <b>display with illumination</b> , cutout approx. 36 x 15 mm (W x H), for displaying the <b>ACTUAL temperature</b> and the <b>internal diagnostics</b> (measuring range exceeded, measuring range not reached, sensor breakage, sensor short circuit)

Display and internal diagnostics

**THERMASGARD®**  
**Measuring transducer with display**

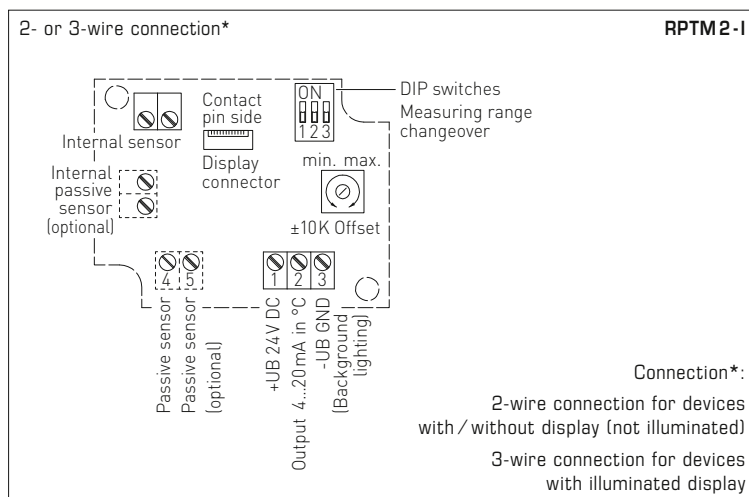
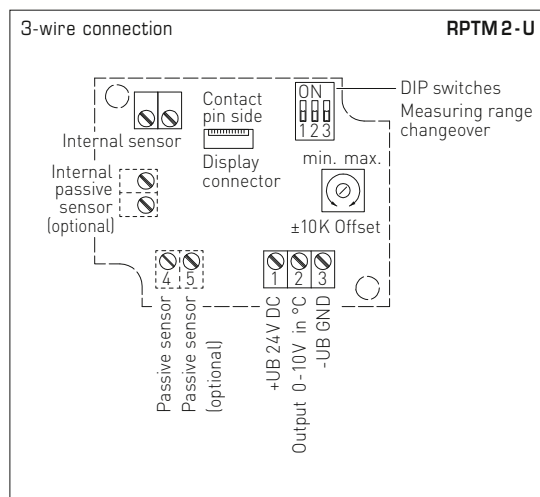
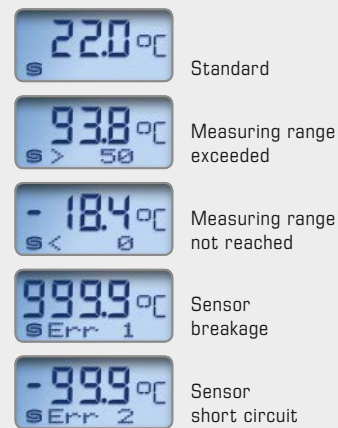

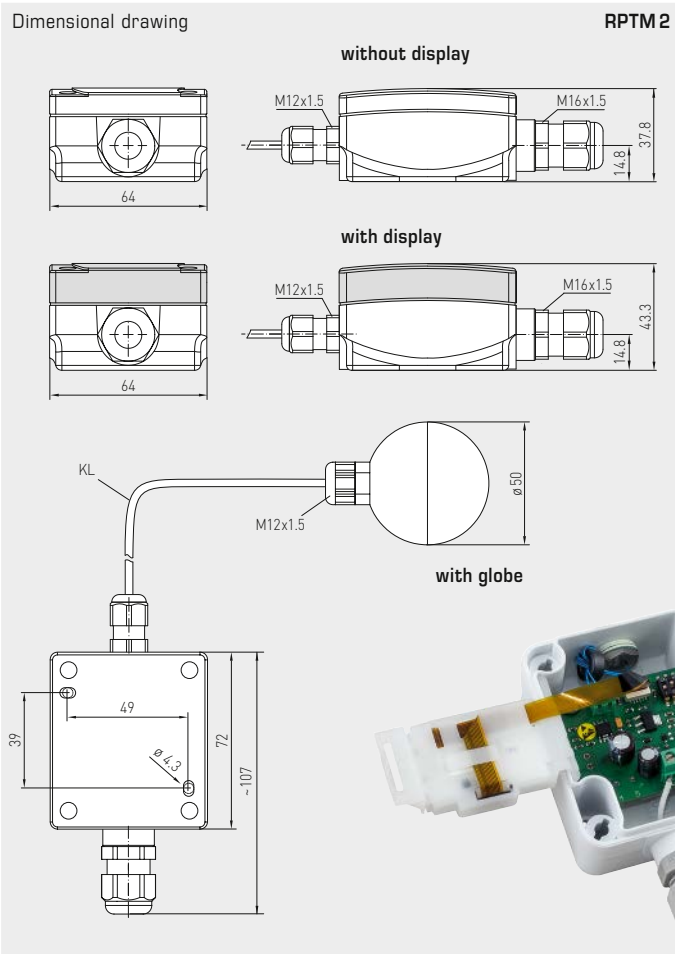

M12 connector (optional on request)



Measuring ranges (adjustable)	DIP 1	DIP 2	DIP 3
-20...+150 °C	ON	ON	ON
-50... +50 °C	OFF	ON	ON
-20... +80 °C	ON	OFF	ON
-30... +60 °C	OFF	OFF	ON
0... +40 °C	ON	ON	OFF
0... +50 °C (default)	OFF	ON	OFF
0...+100 °C	ON	OFF	OFF
0...+150 °C	OFF	OFF	OFF

(observe max. permissible temperature ranges!)



Dependency of output voltage on output current

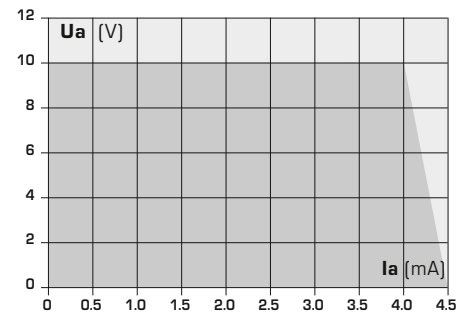

THERMASGARD® RPTM 2 Pendulum room temperature measuring transducers (with globe)					
Type / WG01	Sensor	Output	Type	Item No.	Price
<b>RPTM 2-I</b>					
RPTM2-I	Pt1000	4...20mA	Remote sensor	1101-1172-0219-910	145,49 €
<b>RPTM 2-U</b>					
RPTM2-U	Pt1000	0-10 V	Remote sensor	1101-1171-0219-910	145,49 €
Extra charge:	Other ranges optional				24,19 €
	Two-line display with illumination				47,46 €
	2-wire connecting leads, per running meter (PVC)				on request
	Cable connection with M12 connector according to DIN EN 61076-2-101				on request

**Top hat rail measuring transducers for temperature with multi-range switching and active output**

The top hat rail measuring transducer **THERMASGARD® HSM** is an analogue temperature measuring transducer for Pt100 or Pt1000 sensors according to DIN 60751, with 13 switchable measuring ranges (selectable via DIP switches). It is installed inside control cabinets or distribution boxes. The top hat rail transmitter converts the sensor's temperature-dependent resistance signal into a standard signal of 0 - 10 V or 4...20 mA. The output signal is highly accurate temperature linear. The measuring transducer is factory-calibrated.

**TECHNICAL DATA**

Output:	0 - 10V	4...20 mA
Power supply:	24 V AC / DC ±10 %	24 V DC
Power consumption:	< 0.2 VA / 24 V AC / DC	< 0.55 VA / 24 V DC
Input:	Pt100 / Pt1000	Pt100 / Pt1000
Testing current:	0.25 mA	0.25 mA
Zero point:	-200...+830 °C	-200...+830 °C
Range:	> +20 °C	> +20 °C
Sensor breakage:	> 10 V	> 20 mA
Short circuit:	0 V	< 4 mA
Residual ripple permissible:	< 10 %	< 10 %
Output:	0 - 10V min. load resistance 3 kOhm	4...20 mA max. working resistance $R_a \text{ (Ohm)} = U_B - 12 \text{ V} / 0.02 \text{ A}$
Response time:	< 0.1 s	< 0.1 s
Operating temperature:	-40...+85 °C	-40...+85 °C
Housing:	2TE (75 x 25 x 53 mm) material polycarbonate, colour signal green (similar to RAL 6029)	
Protection class:	III (according to EN 60 730)	
Protection type:	<b>IP 20</b> (according to EN 60 529)	
Standards:	CE conformity, electromagnetic compatibility according to EN 61 326, EMC directive 2014 / 30 / EU	

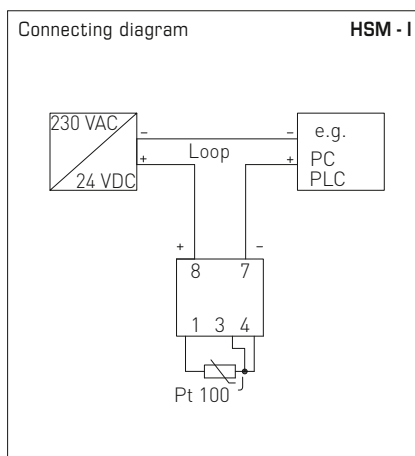
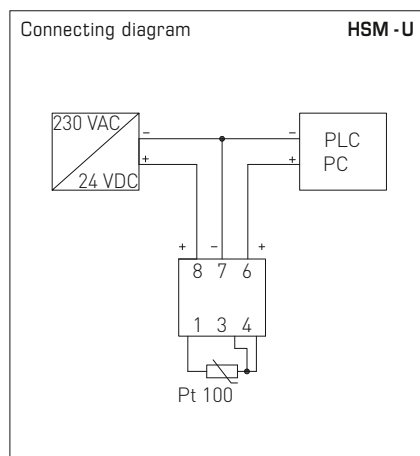

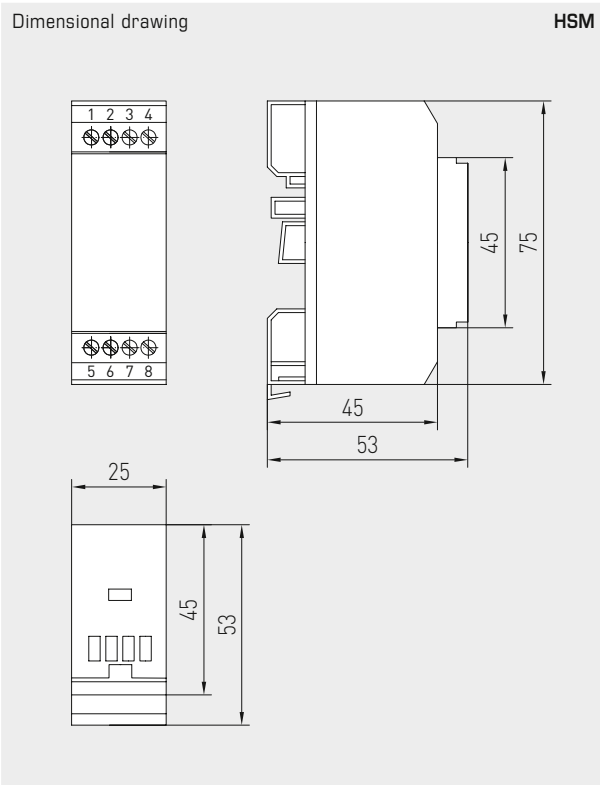

HSM



Measuring ranges (adjustable)	DIP 1	DIP 2	DIP 3	DIP 4
-20...+150 °C	ON	ON	ON	ON
0... +50 °C (default)	OFF	ON	ON	ON
0...+100 °C	ON	OFF	ON	ON
0...+200 °C	OFF	OFF	ON	ON
0...+300 °C	ON	ON	OFF	ON
0...+400 °C *	OFF	ON	OFF	ON
0...+500 °C *	ON	OFF	OFF	ON
0...+600 °C *	OFF	OFF	OFF	ON
-50... +50 °C	ON	ON	ON	OFF
-100...+100 °C	OFF	ON	ON	OFF
-30... +70 °C	ON	OFF	ON	OFF
-40... +60 °C	OFF	OFF	ON	OFF
0...+250 °C	ON	ON	OFF	OFF

\* measuring ranges only for Pt100

THERMASREG® HSM Top hat rail measuring transducers for temperature				
Type / WG01	Sensor	Output	Item No.	Price
<b>HSM-I</b>			<b>IP20, I-variant</b>	
HSM-I	Pt100 / Pt1000	4...20 mA	1101-6112-0009-700	133,89 €
<b>HSM-U</b>			<b>IP20, U-variant</b>	
HSM-U	Pt100 / Pt1000	0 - 10 V	1101-6111-0009-700	133,89 €
Extra charge:	Other ranges optional			24,19 €
For special orders please specify:	Type and measuring range (MR) e.g. HSM-U, Pt100, (MR: 0...+450 °C); HSM-I, Pt100, (MR: 0...+550 °C)			





## Temperature CONTROL DEVICES

Our **THERMASREG®** temperature controllers and thermostats are known for their rugged, long-life and reliable measuring technology, widely field-proven in everyday use. Well engineered and manufactured in customized versions, these devices have a perfect fit in high-end installations.

### APPLICATION RANGE

- > Office and administration buildings
- > Schools, hotels and public authorities
- > Power plants and district heating facilities
- > Industrial buildings and production plants
- > Food industry
- > Heating and ventilation systems



## THERMASREG®

318 – 359

### Room temperature controllers

<b>RTR-B</b>	Room temperature controller	<b>321</b>
<b>RTR-S</b>	Room temperature controller, fan coil controller	<b>323</b>
<b>RTR-E-UP</b>	Room temperature controller, clock thermostat	<b>327</b>
<b>TET</b>	Top hat rail thermostat	<b>359</b>

### Surface contact thermostats

<b>ALTR 060</b>	Surface-contact thermostat	<b>344</b>
<b>ALTR 090</b>	Surface-contact thermostat	<b>344</b>
<b>ALTR 1</b>	Surface-contact thermostat	<b>345</b>
<b>ALTR 3</b>	Surface-contact thermostat	<b>345</b>
<b>ALTR 5</b>	Surface-contact thermostat	<b>345</b>
<b>ALTR 7</b>	Surface-contact thermostat	<b>345</b>

### Built-in controllers, duct controllers

<b>ETR</b>	Built-in temperature controller, one-step / two-step	<b>335</b>
<b>KTR</b>	Duct temperature controller, one-step / two-step	<b>341</b>
<b>TRxx-F</b>	Temperature controller with remote sensor	<b>331</b>
<b>FST-K</b>	Duct frost protection thermostat, mechanical, one-step, switching	<b>353</b>

### Wet room temperature controllers

<b>TR040</b>	Temperature controller	<b>328</b>
<b>TR060</b>	Temperature controller	<b>328</b>
<b>TR 22</b>	Temperature controller	<b>329</b>
<b>TR04040</b>	Temperature controller, two-step	<b>330</b>

### Frost protection thermostats

<b>FST</b>	Frost protection thermostat, mechanical, one-step, switching	<b>349</b>
<b>FST-K</b>	Duct frost protection thermostat, mechanical, one-step, switching	<b>353</b>
<b>FS-20</b>	2-phase frost protection thermostat, with control and cascading input, two-step, switching	<b>357</b>

### Immersion sleeves and accessories

see chapter Accessories	<b>636</b>
-------------------------	------------

Room temperature controllers, mechanical, on-wall

One-step mechanical single room controller **THERMASREG® RTR-B** in bi-metal technology with thermal feedback for monitoring or controlling temperatures in dry rooms, or for activating any kind of heating system as room thermostat. For currentless open radiator valves, the cooling output from the changeover contact (normally open contact) must be connected. At breaker contacts, a maximum of 10 valve actuators can be connected and at normally open contacts a maximum of 5 valve actuators.

**TECHNICAL DATA**

Switching capacity: (Contact load)	230 V AC, 50-60 Hz heating: 10 mA...10 (4) A, DC 30 W cooling: 10 mA...5 (2) A
Sensor element:	bi-metal
Control range:	+5...+30 °C
Output:	breaker or changeover contact
Operating difference:	approx. 0.5 K
Housing:	plastic, material ABS, colour pure white (similar to RAL 9010)
Dimensions:	75 x 75 x 25 mm (E1)
Electrical connection:	0.14-2.5 mm <sup>2</sup> via terminal screws
Installation:	wall mounting or on in-wall flush box Ø55 mm, base with 4-hole for mounting on vertically or horizontally installed in-wall flush boxes for cable entry from the back, with predetermined breaking point for on-wall cable entry from top/bottom in case of plain on-wall installation
Protection class:	II (according to EN 60 730)
Protection type:	<b>IP 30</b> (according to EN 60 529)
Standards:	CE conformity, EMC directive 2014 / 30 / EU, low-voltage directive 2014 / 35 / EU

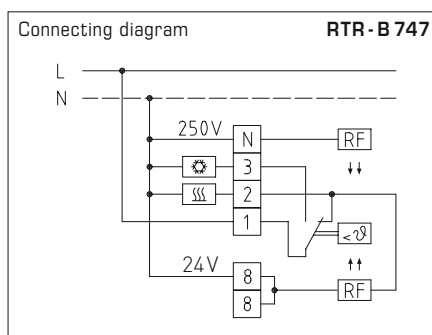
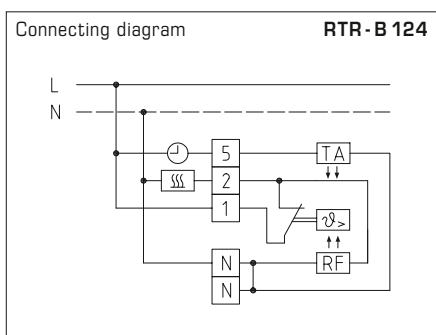
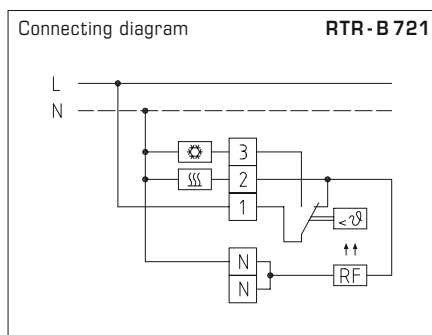
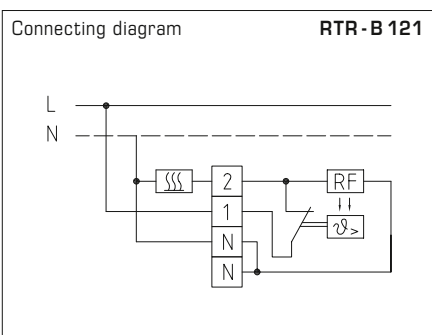



S+S REGELTECHNIK

THERMASREG® RTR-B

Room temperature controllers, mechanical, on-wall

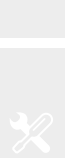

Dimensional drawing

Housing E1  
(Picture similar)

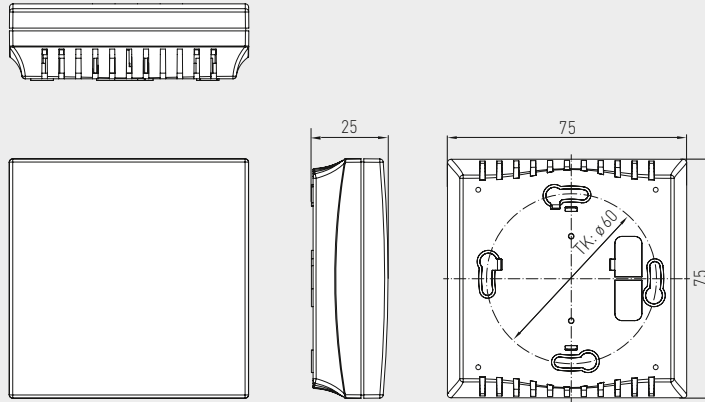

RTR-B 747  
with internal setting



Dimensional drawing

Housing E1  
with one potentiometer  
(Picture similar)

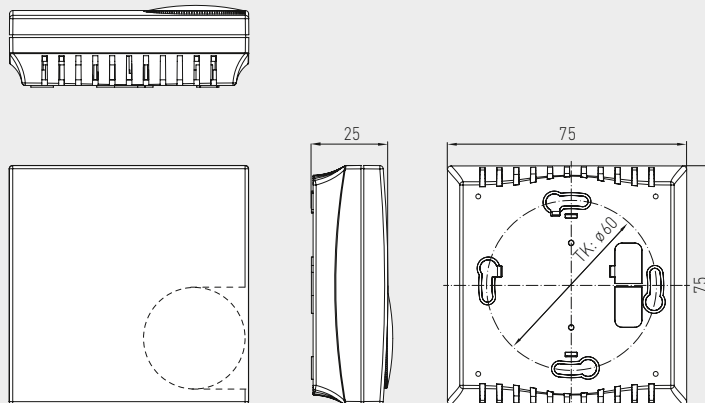

RTR-B 121  
RTR-B 124  
RTR-B 721  
with external setting



THERMASREG® RTR-B Room temperature controllers

Type / WG01	Temperature Range	Function	Output	Item No.	Price
<b>RTR-B 121 / B 124 / B 721</b>				<b>External setting</b>	
RTR-B 121	+5...+30 °C	Heating	Breaker	1102-4011-2100-000	<b>32,72 €</b>
RTR-B 124	+5...+30 °C	Heating, temperature reduction -5 K	Breaker	1102-4011-2400-000	<b>34,58 €</b>
RTR-B 721	+5...+30 °C	Heating, cooling	Changeover contact	1102-4017-2100-000	<b>36,01 €</b>
<b>RTR-B 747</b>				<b>Internal setting</b>	
RTR-B 747	+5...+30 °C	Heating, cooling	Changeover contact	1102-4017-4700-000	<b>39,28 €</b>

Room temperature controllers, continuous,  
on-wall, general

Electronic room temperature controllers, climate controllers **THERMASREG® RTR-S** for monitoring or controlling temperatures with output 0 - 10V for heating and cooling, optional as continuous climate controller with manual ventilator speed regulation, setpoint adjustment, and LED status indicators. Application in dry individual rooms heated or cooled by radiators, cooling ceilings, or ventilation, or air conditioning systems, or as remote control unit for air conditioners, e.g. in hotels, offices, or hospitals or as room thermostat.

**TECHNICAL DATA**

Power supply:	24 V AC / DC (± 10%)
Temperature sensor:	internal or external (selectable via jumper) Pt 1000 according to DIN EN 60751, class B
Control range:	+5...+30 °C, adjustable via setpoint potentiometer with numerical scale or +21 °C (± 8 K), adjustable via setpoint potentiometer with swelling arrow (central position / + / -)
Output:	<b>1 x heating, 1 x cooling,</b> 0 - 10 V or 10 - 0 V repluggable, max. 5 mA
Proportional band:	internally adjustable via potentiometer <b>heating</b> +0.5...+3 K (1 K factory setting) <b>cooling</b> +0.5...+3 K (2 K factory setting)
Neutral zone:	internally adjustable via potentiometer, +1...+5 K (1K factory setting)
Control mode:	PI
Housing:	plastic, material ABS, colour pure white (similar to RAL 9010)
Dimensions:	98 x 98 x 33 mm (Baldur 2)
Installation:	wall mounting or on in-wall flush box Ø 55 mm, base with 4-hole for mounting on vertically or horizontally installed in-wall flush boxes for cable entry from the back, with predetermined breaking point for on-wall cable entry from top/bottom in case of plain on-wall installation
Electrical connection:	0.14 - 2.5 mm <sup>2</sup> via terminal screws
Humidity:	max. 90% r. H., non-precipitating air
Protection class:	III (according to EN 60 730)
Protection type:	<b>IP 30</b> (according to EN 60 529)
Standards:	CE conformity, electromagnetic compatibility according to EN 61 326, EMC directive 2014 / 30 / EU

Dimensional drawing

Housing **Baldur 2**

(one or two potentiometers possible)

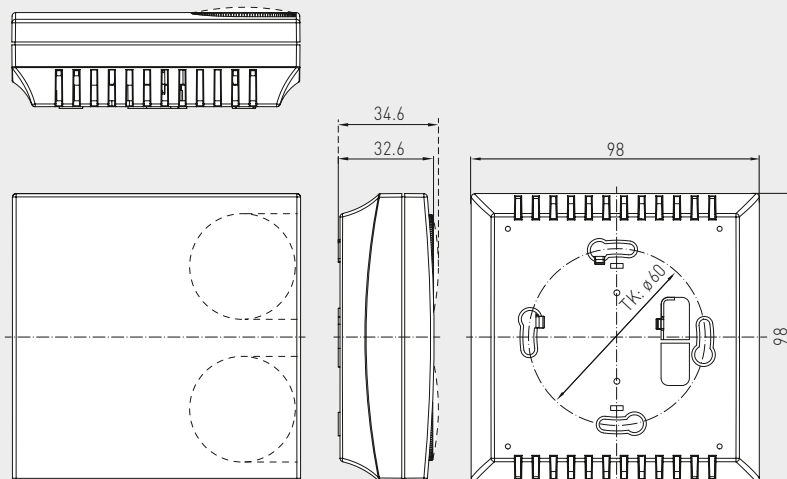





**RTR-S010**  
(BalduR2)  
Continuous room temperature controller for 2-channel single room control

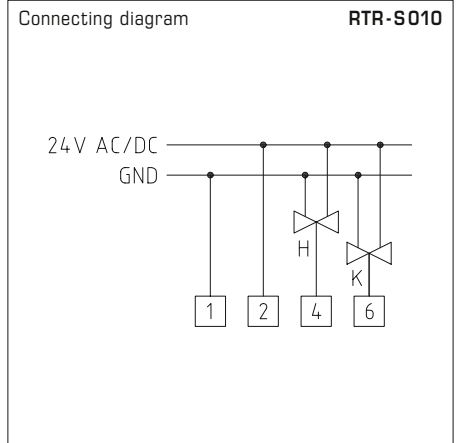

**THERMASREG® RTR-S010** Room temperature controller

Type / WG01	Sensor internal / external	Output Heating	Output Cooling	Item No.	Price
<b>RTR-S010</b>				<b>External setting</b>	
RTR-S 010	Pt1000	0 - 10 V	0 - 10 V	1102-40B0-1000-000	<b>172,48 €</b>
Features:	+5...+30 °C, via setpoint device, numerical scale				



**RTR-S011**  
(BalduR2)  
Continuous room temperature controller for 2-channel single room control

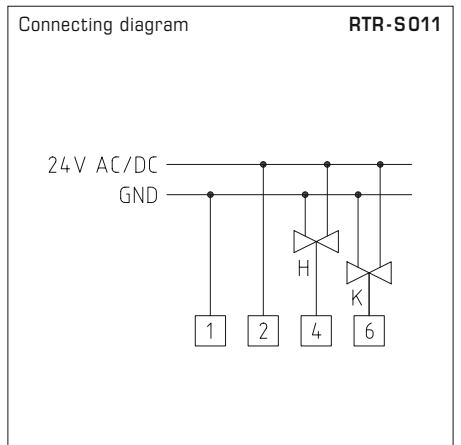

**THERMASREG® RTR-S011** Room temperature controller

Type / WG01	Sensor internal / external	Output Heating	Output Cooling	Item No.	Price
<b>RTR-S011</b>				<b>External setting</b>	
RTR-S 011	Pt1000	0 - 10 V	0 - 10 V	1102-40B0-1100-000	<b>172,48 €</b>
Features:	+21 °C (±8K), via setpoint device, swelling arrow (central position / + / -)				

Room temperature controllers, continuous, on-wall, different versions



**RTR-S 012**  
(Baldur 2)

Continuous room temperature controller for 2-channel single room control, with LED operating mode indicator

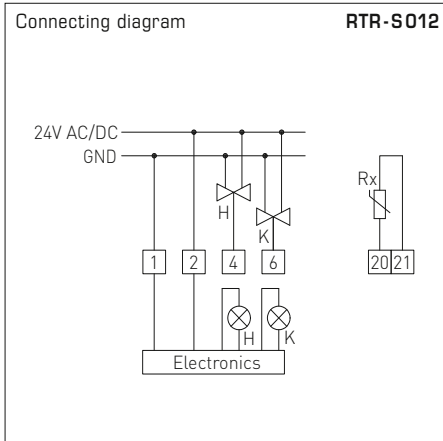

**THERMASREG® RTR-S 012** Room temperature controller

Type/WG01	Sensor internal/external	Output Heating	Output Cooling	Item No.	Price
<b>RTR-S012</b>				<b>External setting</b>	
RTR-S 012	Pt1000	0 - 10V	0 - 10V	1102-4080-1200-000	<b>179,81 €</b>
Features:		+5...+30 °C, via setpoint device, numerical scale, LED red: operating mode heating, LED blue: operating mode cooling			



**RTR-S 013**  
(Baldur 2)

Continuous room temperature controller for 2-channel single room control, with LED operating mode indicator

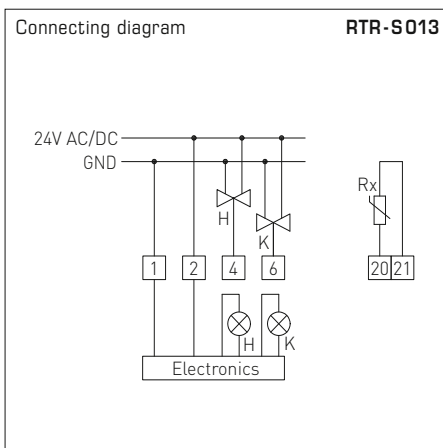

**THERMASREG® RTR-S 013** Room temperature controller

Type/WG01	Sensor internal/external	Output Heating	Output Cooling	Item No.	Price
<b>RTR-S013</b>				<b>External setting</b>	
RTR-S 013	Pt1000	0 - 10V	0 - 10V	1102-4080-1300-000	<b>179,81 €</b>
Features:		+21 °C (±8K) via setpoint device, swelling arrow (central position / + / -), LED red: operating mode heating, LED blue: operating mode cooling			



**RTR-S014**  
(BalduR2)

Continuous room temperature controller for 2-channel single room control with LED operating mode indicator and 3-speed selector switch for ventilators

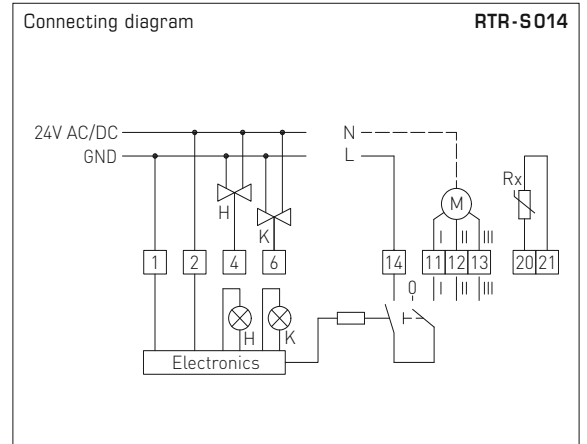

**THERMASREG® RTR-S014** Room temperature controller

Type / WG01	Sensor internal/external	Output Heating	Output Cooling	Item No.	Price
<b>RTR-S014</b>				<b>External setting</b>	
RTR-S 014	Pt1000	0 - 10V	0 - 10V	1102-40B0-1400-000	<b>187,15 €</b>
Features:					
+5...+30 °C, via setpoint device, numerical scale, internal / external sensor selectable LED red: operating mode heating, LED blue: operating mode cooling, 4-step turn switch for ventilator speed (0 / I / II / III)					



**RTR-S015**  
(BalduR2)

Continuous room temperature controller for 2-channel single room control with LED operating mode indicator and 3-speed selector switch for ventilators

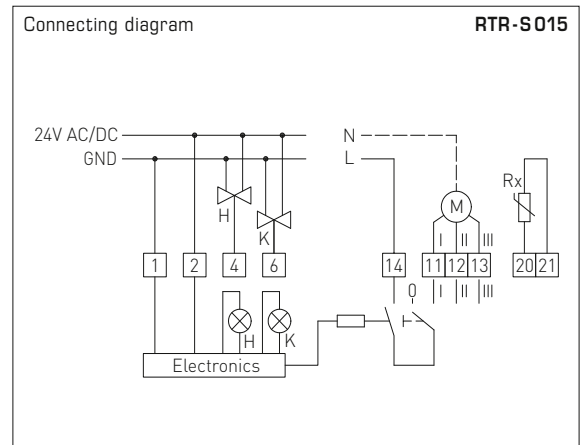

**THERMASREG® RTR-S015** Room temperature controller

Type / WG01	Sensor internal/external	Output Heating	Output Cooling	Item No.	Price
<b>RTR-S015</b>				<b>External setting</b>	
RTR-S 015	Pt1000	0 - 10V	0 - 10V	1102-40B0-1500-000	<b>187,15 €</b>
Features:					
+21 °C (±8K) via setpoint device, swelling arrow (central position / + / -), LED red: operating mode heating, LED blue: operating mode cooling, 4-step turn switch for ventilator speed (0 / I / II / III)					

**Room temperature controllers,  
in-wall, general**

Electronic single-room controllers / clock thermostats with week program **THERMASREG® RTR-E-UP** with internal sensor or 4-meter remote sensor for in-wall installation suitable for temperature monitoring and control, for activating any kind of heating system and valves (closed when currentless), as room temperature controller, room thermostat, floor temperature controller, or clock controller, e. g. for electric floor direct heating systems, for bathrooms, for night storage, wall, ceiling and gas heating systems.

**TECHNICAL DATA**

Power supply:	230 V AC, 50 Hz
Temperature sensor:	NTC according to DIN 44574, sensor extension up to max. 50 m, with double insulation according to EN 60730-2-1
Control range:	see table +15...+30 °C for room temperature controllers +10...+60 °C for floor temperature controllers +15...+30 °C and +20...+60 °C for combined controllers
Accuracy:	typically ± 5 %
Output:	1x normally open contact (single ended)
Switching capacity:	3.6 kW
Switching current: (Contact load)	16 A (ohmic load)
Safety:	with sensor breakage and sensor short circuit protection (in case of sensor breakage or sensor short circuit heating is switched of)
Operating difference:	approx. 0.6 K
Housing:	plastic, colour pure white (similar RAL 9010)
Dimensions:	80 x 80 x 16 mm
Electrical connection:	0.14 - 2.5 mm <sup>2</sup> via terminal screws
Temperature range limitation:	in the turning knob
Installation:	in in-wall flush box Ø = 55 mm
Protection class:	II (according to EN 60 730)
Protection type:	<b>IP 30</b> (according to EN 60 529)
Standards:	CE conformity, electromagnetic compatibility according to EN 61 326, EMC directive 2014 / 30 / EU, low-voltage directive 2014 / 35 / EU

Dimensional drawing

RTR-E-UP

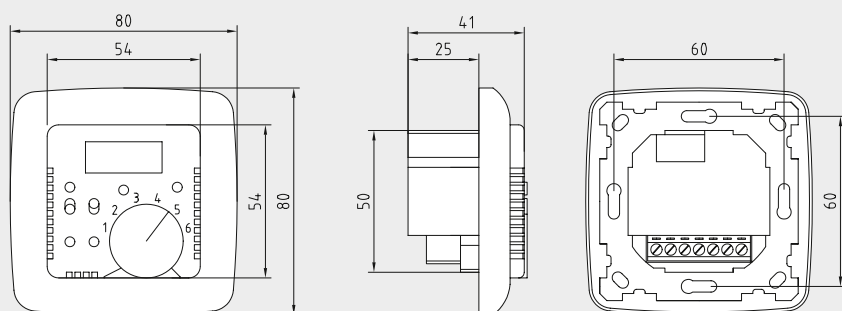

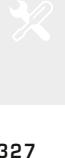
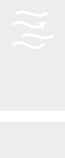

RTR-E 6005  
RTR-E 6009  
RTR-E 6011

Room temperature controller for single room control with LED operating mode indicator

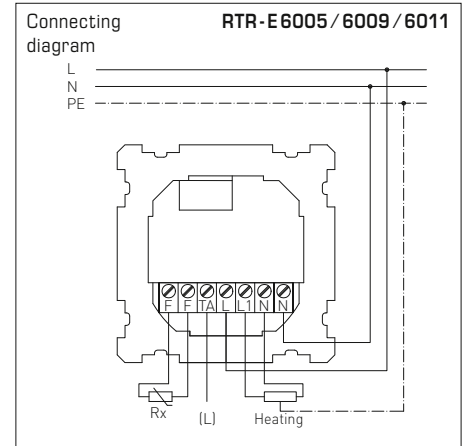

THERMASREG® RTR - E 6005 / 6009 / 6011 Room temperature controllers

Type / WG01	Temperature Range	Sensor	Function Heating	Item No.	Price
<b>RTR-E 6005 / 6009 / 6011</b>				<b>IP30</b>	
RTR-E 6005	+5...+30 °C	Room sensor, Sensor Internal	Room temperature controller	1102-5010-0050-000	121,86 €
RTR-E 6009	+10...+60 °C	with remote sensor (L = 4 m)	Floor temperature controller	1102-5010-0090-000	123,06 €
RTR-E 6011	+5...+30 °C / +20...+60 °C	Room sensor, Sensor Internal, with remote sensor (L = 4 m)	Room temperature controller and floor temperature monitor (combined controller)	1102-5010-0110-000	144,89 €
Features:	with night temperature setback, main switch, and LED operating mode indicator				



RTR-E 6020  
RTR-E 6025

Room temperature controller for single room control with LED operating mode indicator, LC display, and clock

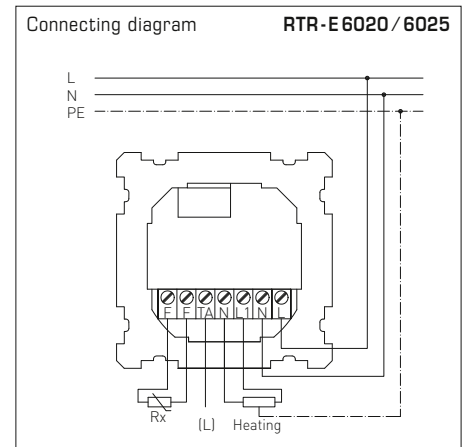

THERMASREG® RTR - E 6020 / 6025 Room temperature controllers

Type / WG01	Temperature Range	Sensor	Function Heating	Item No.	Price
<b>RTR-E 6005 / 6009 / 6011</b>				<b>IP30</b>	
RTR-E 6020	+5...+30 °C	Room sensor, Sensor Internal	Room temperature controller with clock	1102-5010-0200-000	173,99 €
RTR-E 6025	+10...+60 °C	with remote sensor (L = 4 m)	Floor temperature controller with clock	1102-5010-0250-000	185,62 €
Features:	with week programme, main switch, party switch, LC display, and LED operating mode indicator				



**Temperature controllers, one-step,  
with switching output**

Mechanical temperature controllers/wet room temperature controllers **THERMASREG® TR 040 / TR 060** with switching output (one-step) and stainless steel capillary (spiral coil sensor), working without external voltage. They are used for monitoring and controlling temperatures in heat generation plants, in heating, ventilation and air conditioning systems, for ventilation, cooling and climate control in halls, cold storage rooms, greenhouses, nurseries, stables, breeding rooms, as industrial room thermostat or surface-mounted thermostat in industrial applications as well as in wet room and outdoor areas.

**TECHNICAL DATA**

Switching capacity: (Contact load)	24...250V AC +10%, 16A, cos φ = 1.0 24...250V AC +10%, 1.5A, cos φ = 0.6 at 24V AC min. 150mA
Contact:	dust-proof switch block unit as potential-free, single-pole or two-pole changeover contact
Housing:	plastic, UV-resistant, material polyamide, 30% glass-globe reinforced, colour traffic white (similar to RAL 9016)
Housing dimensions:	108 x 70 x 73.5 mm (Thor 2)
Cable gland:	M20 x 1.5; including strain relief
Housing temperature:	-35...+65 °C
Capillary:	stainless steel <b>V2A</b> (1.4303)
Tolerance:	T <sub>min</sub> ± 3K; T <sub>max</sub> ± 3K; at +20°C ± 1K
Electrical connection:	0.14 - 2.5 mm <sup>2</sup> via terminal screws
Routing:	admissible vibration load ≤ ½g
Protection class:	I (according to EN 60 730)
Protection type:	<b>IP 65</b> (according to EN 60 529)
Standards:	CE conformity, EMC directive 2014 / 30 / EU, low-voltage directive 2014 / 35 / EU

**FUNCTION**

- Heating:** The preset setpoint (scale value) is equivalent to the switch-off value of the heating. The switch-on value is lower by the amount of operating difference. Contact 2-3 breaks when temperature rises to the preset value.
- Cooling:** The preset setpoint (scale value) is equivalent to the switch-on value of the cooling. The switch-off value is lower by the amount of operating difference. Contact 1-2 closes when temperature rises to the preset value.

Dimensional drawing

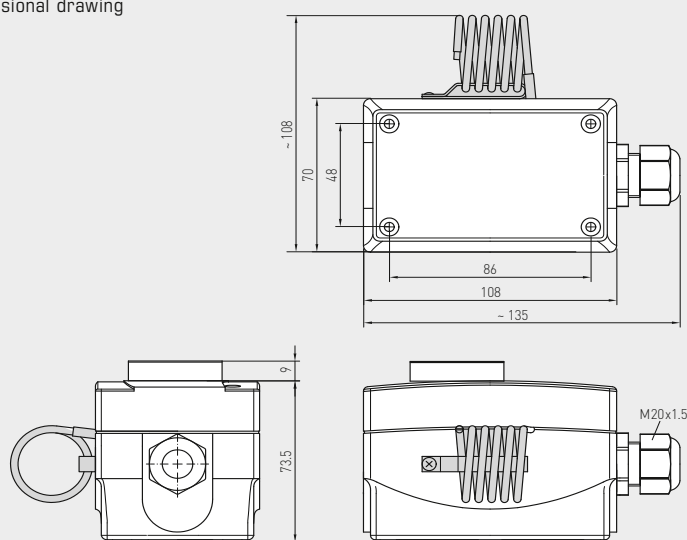

**TR 040**  
**TR 060**

**TR 040**  
**TR 060**  
(one-step)  
**TR**



**TR 040 U**  
**TR 060 U**  
(one-step)  
**TW**



Connecting diagram

**TR 040**  
**TR 060**

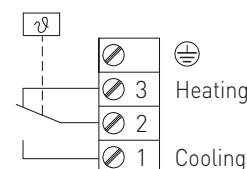

**THERMASREG® TR 040 / TR 060** Temperature controllers, one-step

Type / WG01	Temperature Range	Thermal Operating Difference (fixed) approx.	Max. Capillary Temperature	Item No.	Price
<b>TR 040 / 060</b>				<b>TR</b> (External setting)	
TR-040	0...+40 °C	2K	+65 °C	1102-1050-1100-200	<b>75,00 €</b>
TR-060	0...+60 °C	2K	+75 °C	1102-1050-1100-300	<b>75,00 €</b>
<b>TR 040 U / 060 U</b>				<b>TW</b> (Internal setting)	
TR-040 U	0...+40 °C	2K	+65 °C	1102-1050-2100-200	<b>73,79 €</b>
TR-060 U	0...+60 °C	2K	+75 °C	1102-1050-2100-300	<b>73,79 €</b>



Mechanical temperature controller / wet room temperature controller **THERMASREG® TR 22** with switching output (one-step) and copper capillary, working without external voltage. It is used for monitoring and controlling temperatures in heat generation plants, in heating, ventilation and air conditioning systems, for ventilation, cooling and climate control in halls, cold storage rooms, greenhouses, nurseries, stables, breeding rooms, as industrial room thermostat or surface-mounted thermostat in industrial applications as well as in wet room and outdoor areas.

**TR 22**  
(one-step)  
**TR**

**TECHNICAL DATA**

Switching capacity: (Contact load)	24...250V AC +10%, 16A, cos φ = 1.0 24...250V AC +10%, 1.5A, cos φ = 0.6 at 24V AC min. 150mA
Contact:	dust-proof switch block unit as potential-free single-pole changeover contact
Housing:	plastic, UV-resistant, material polyamide, 30% glass-globe reinforced, colour traffic white (similar to RAL 9016)
Housing dimensions:	108 x 70 x 73.5 mm (Thor 2)
Cable gland:	M20 x 1.5; including strain relief
Housing temperature:	-35...+65 °C
Design principle:	torsion meter with liquid filling
Capillary:	copper
Tolerance:	T <sub>min</sub> ± 3K; T <sub>max</sub> ± 3K
Routing:	admissible vibration load ≤ ½g
Electrical connection:	0.14 - 2.5 mm² via terminal screws
Protection class:	I (according to EN 60 730)
Protection type:	<b>IP 65</b> (according to EN 60 529)
Standards:	CE conformity, EMC directive 2014 / 30 / EU, low-voltage directive 2014 / 35 / EU

**FUNCTION**

- Heating:** The preset setpoint (scale value) is equivalent to the switch-off value of the heating. The switch-on value is lower by the amount of operating difference. Contact 2 - 3 breaks when temperature rises to the preset value.
- Cooling:** The preset setpoint (scale value) is equivalent to the switch-on value of the cooling. The switch-off value is lower by the amount of operating difference. Contact 1 - 2 closes when temperature rises to the preset value.



**TR 22 U**  
(one-step)  
**TW**



Dimensional drawing

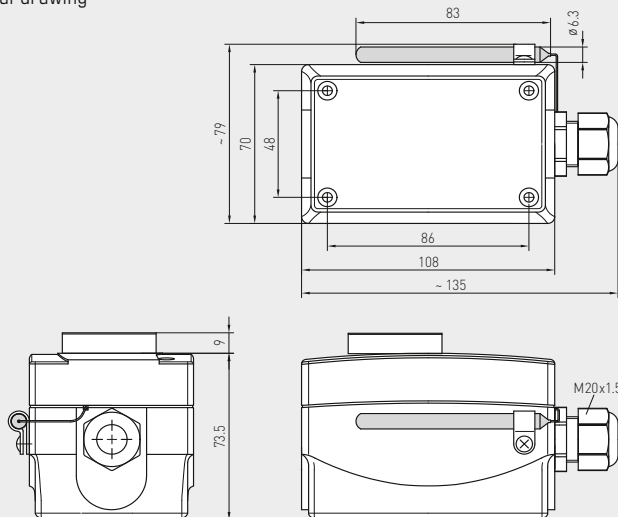

**TR 22**

Connecting diagram

**TR 22**

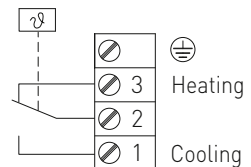

**THERMASREG® TR 22** Temperature controllers, one-step

Type / WG01	Temperature Range	Thermal Operating Difference (fixed) approx.	Max. Capillary Temperature	Item No.	Price
<b>TR 22</b>				<b>TR</b> (External setting)	
TR-22	-35...+35 °C	3K (± 1K)	+60 °C	1102-1050-1100-100	<b>75,00 €</b>
<b>TR 22 U</b>				<b>TW</b> (Internal setting)	
TR-22 U	-35...+35 °C	3K (± 1K)	+60 °C	1102-1050-2100-100	<b>73,79 €</b>

**Temperature controllers, two-step,  
with switching output**

Mechanical temperature controller/wet room temperature controller **THERMASREG® TR 04040** with two independently switching outputs, which are separately adjustable (e.g. for switching between day and night time) and stainless steel capillary (spiral coil sensor), working without external voltage. It is used for monitoring and controlling temperatures in heat generation plants, in heating, ventilation and air conditioning systems, for ventilation, cooling and climate control in halls, cold storage rooms, greenhouses, nurseries, stables, breeding rooms, as industrial room thermostat or surface-mounted thermostat in industrial applications as well as in wet room and outdoor areas.

**TECHNICAL DATA**

Switching capacity:	24...250V AC +10%, 16A, cos φ = 1.0 (Contact load) 24...250V AC +10%, 1.5A, cos φ = 0.6 at 24V AC min. 150mA
Contact:	dust-proof switch block unit as potential-free single-pole changeover contact (two changeover contacts, separately adjustable)
Housing:	plastic, UV-resistant, material polyamide, 30% glass-globe reinforced, colour traffic white (similar to RAL 9016)
Housing dimensions:	108 x 70 x 73.5 mm (Thor 2)
Cable gland:	2x M20 x 1.5; including strain relief
Housing temperature:	-10...+65 °C
Capillary:	stainless steel <b>V2A</b> (1.4303)
Tolerance:	T <sub>min</sub> ± 3K; T <sub>max</sub> ± 3K; at +20 °C ± 1K
Electrical connection:	0.14 - 2.5 mm <sup>2</sup> via terminal screws
Routing:	admissible vibration load ≤ ½g
Protection class:	I (according to EN 60 730)
Protection type:	<b>IP 65</b> (according to EN 60 529)
Standards:	CE conformity, EMC directive 2014 / 30 / EU, low-voltage directive 2014 / 35 / EU

**FUNCTION**

**Heating:** Contacts 2-3 and 5-6 break when temperature rises to the preset value.  
**Cooling:** Contacts 2-1 and 5-4 break when temperature drops to the preset value.

Dimensional drawing **TR 04040**

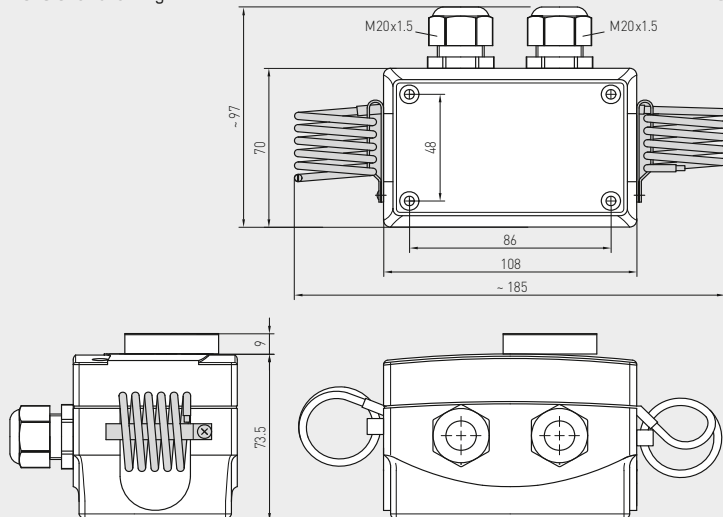

**TR 04040**



**TR 04040 U**

Connecting diagram **TR 04040**

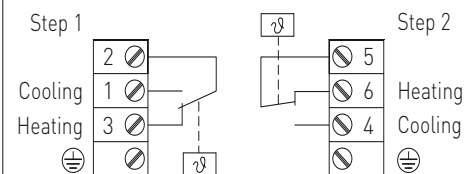

**THERMASREG® TR 04040** Temperature controllers, two-step

Type / WG01	Temperature Range (adjustable)		Thermal Operating Difference (fixed) approx.		Max. Capillary Temperature	Item No.	Price
	1.	2.	1.	2.			
<b>TR 04040</b>						<b>TR+TW</b> (External/Internal setting)	
TR-04040	0...+40 °C	0...+40 °C	2K	2K	+65 °C	1102-1050-1200-200	<b>110,32 €</b>
<b>TR 04040 U</b>						<b>TW+TW</b> (Internal setting)	
TR-04040 U	0...+40 °C	0...+40 °C	2K	2K	+65 °C	1102-1050-2200-200	<b>110,32 €</b>



Mechanical temperature controller THERMASREG® TR xx-F with remote sensor and switching output (one-step), working as capillary thermostat / capillary controller without external voltage. This capillary controller is used for monitoring and to control temperatures of non-aggressive liquid or gaseous media in heating, ventilation and air conditioning technology as well as in mechanical and apparatus engineering, for installation in immersion sleeves or air conditioning ducts.

TECHNICAL DATA	
Switching capacity: (Contact load)	24...250 V AC +10%, 16 A, cos φ = 1.0 24...250 V AC +10%, 1.5 A, cos φ = 0.6 at 24 V AC min. 150 mA
Contact:	dust-proof switch block unit as potential-free single-pole changeover contact
Housing:	plastic, UV-resistant, material polyamide, 30% glass-globe reinforced, colour traffic white (similar to RAL 9016)
Housing dimensions:	108 x 70 x 73.5 mm (Thor 2)
Cable gland:	M20 x 1.5; including strain relief
Housing temperature:	-10...+65 °C
Design principle:	torsion meter with liquid filling
Sensor:	copper tube, length of capillary = 1 m with PVC protective hose, Ø 6.8 mm
Tolerance:	T <sub>min</sub> ± 3 K; T <sub>max</sub> ± 3 K
Inserted length:	immersion sleeves EL = 150 mm (accessories see table)
Routing:	bending radius > 35mm admissible vibration load ≤ ½g admissible tensile load < 100N
Electrical connection:	0.14 - 2.5 mm² via terminal screws
Protection class:	I (according to EN 60 730)
Protection type:	IP 65 (according to EN 60 529)
Standards:	CE conformity, EMC directive 2014 / 30 / EU, low-voltage directive 2014 / 35 / EU

FUNCTION	
	<b>Heating:</b> wire contacts 2 - 3
	<b>Cooling:</b> wire contacts 2 - 1

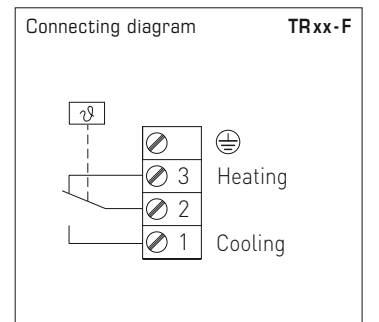
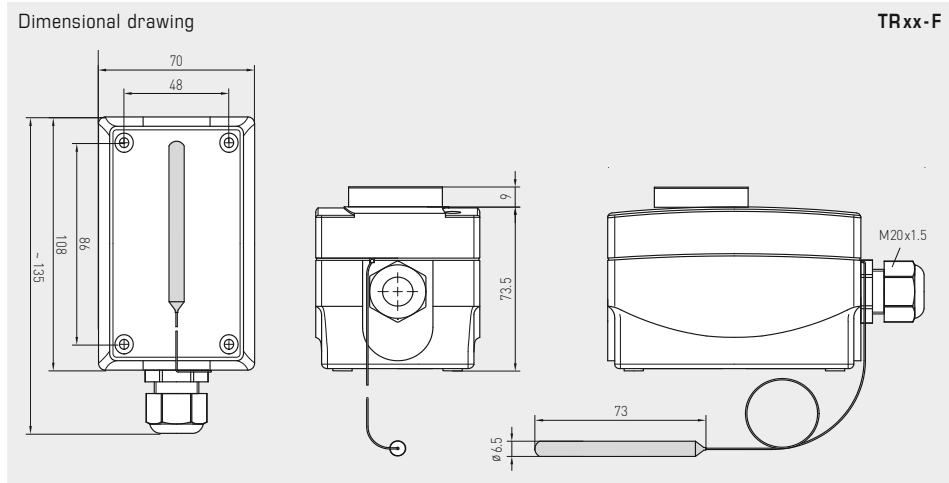

THERMASREG® TR xx - F Temperature controllers, one-step					
Type / WG01	Temperature Range	Thermal Operating Difference (fixed) approx.	Max. Capillary Temperature	Item No.	Price
				<b>TR</b> (External setting)	
TRxx-F					
TR-1-F	-35... +35 °C	3 K (± 1 K)	+60 °C	1102-1056-1110-100	76,01 €
TR-060-F	0... +60 °C	3 K (± 1 K)	+75 °C	1102-1050-1110-300	76,01 €
TR-090-F	0... +90 °C	3 K (± 1 K)	+120 °C	1102-1050-1110-400	76,01 €
TR-0120-F	0...+120 °C	5 K (± 1 K)	+135 °C	1102-1050-1110-500	76,01 €
TR-50140-F	+50...+140 °C	5 K (± 1 K)	+150 °C	1102-1050-1110-600	76,01 €
Extra charge:	U = Internal setting (TW), e.g. TR-090-F-U				9,48 €
ACCESSORIES					
THR-MS-08/150	Brass immersion sleeve, EL = 150 mm, Ø 8 x 0.5 mm			7100-0011-3404-000	14,81 €
THR-VA-09/150	Stainless steel immersion sleeve V2A (1.4301), EL = 150 mm, Ø 9 x 1.0 mm			7100-0012-3032-000	39,04 €

For further information, see the last chapter!

Equipment sensor/controller, including immersion sleeve,  
EC type-tested, TÜV tested,  
with switching output

DIN-tested German quality product. Temperature control and limiting device for heat generation plants in accordance with DIN EN 14597. Safety temperature limiter (STB) with EC type test (module B) according to directive 2014/68/EU.

Mechanical temperature control device/rod thermostat THERMASREG® ETR with switching output, used for monitoring, controlling or limiting the temperatures of liquid or gaseous media as a boiler controller or in heating, air conditioning technology as well as in mechanical and apparatus engineering and in heat generation plants. It is available as one-step or two-step device, as adjustable temperature controller TR, temperature monitor TW, or as safety temperature limiter STB.



**TECHNICAL DATA**

Switching capacity: (Contact load)	24 ... 250 V AC + 10 %, 10 A, cos φ = 1.0 24 ... 250 V AC + 10 %, 1.5 A, cos φ = 0.6 at 24 V AC min. 150 mA
Contact:	dust-proof switch block unit as potential-free single-pole or two-pole changeover contact
Housing:	plastic, UV-resistant, material polyamide, 30% glass-globe reinforced, colour traffic white (similar to RAL 9016)
Housing dimensions:	108 x 70 x 73.5 mm (Thor2)
Cable gland:	M20 x 1.5; including strain relief
Measuring element:	torsion meter with liquid filling, liquid expansion temperature feeler
Mounting position:	arbitrary
Ambient temperature:	-10...+65 °C at the switch block housing
Tolerance:	T <sub>min</sub> ± 5 K; T <sub>max</sub> ± 3 K
Immersion sleeves:	<b>THR-ms-08/xx</b> , Single sleeve brass, nickel-plated, Ø = 8 mm, R ½" straight pipe thread, wrench size 22, p <sub>max</sub> = 10 bar, T <sub>max</sub> = +150 °C <b>THR-VA-09/xx</b> , Single sleeve stainless steel V4A (1.4571), Ø = 9 mm, G ½" straight pipe thread, wrench size 22, p <sub>max</sub> = 25 bar, T <sub>max</sub> = +150 °C <b>THR-VA-17/xx</b> , Double sleeve stainless steel V4A (1.4571), Ø = 17 mm, G ½" straight pipe thread, wrench size 22, p <sub>max</sub> = 25 bar, T <sub>max</sub> = +150 °C (Depending on the type, the relevant immersion sleeve is included in the scope of delivery, see table)
Operating medium:	Water, oil, air and exhaust gas
Inserted length:	100 mm / 150 mm / 200 mm (see table)
Process connection:	screwed socket
Electrical connection:	0.14 - 2.5 mm <sup>2</sup> via terminal screws
Protection class:	I (according to EN 60 730)
Protection type:	<b>IP 65</b> (according to EN 60 529)
Standards:	CE conformity, EMC directive 2014/30/EU, low-voltage directive 2014/35/EU
Tests:	<b>EC type test (module B) according to directive 2014/68/EU</b> , certificate No.: IS-TAF-MUC 18 03 2652130 002, DIN EN 14597, register Nos.: <b>STB 1201, TR/STB 1202</b>
<b>FUNCTION</b>	<b>TW, TR:</b> Contact 2-3 breaks when temperature rises to the preset value. <b>STB:</b> Contact 2-1 or 5-4 (two-step) breaks when temperature rises to the preset value. Restart is possible only after cooling off by approx. 15 K - 20 K by pressing the reset button.







**Configuration variants:**

- TW**  
Temperature monitor  
(internal setting)
  
- TR**  
Temperature controller  
(external setting)
  
- STB**  
Safety temperature limiter  
(internal setting)
  
- TW+TW**  
Double temperature monitor  
(internal setting)
  
- TR + STB**  
Temperature controller  
(external setting) +  
Safety temperature limiter  
(internal setting)

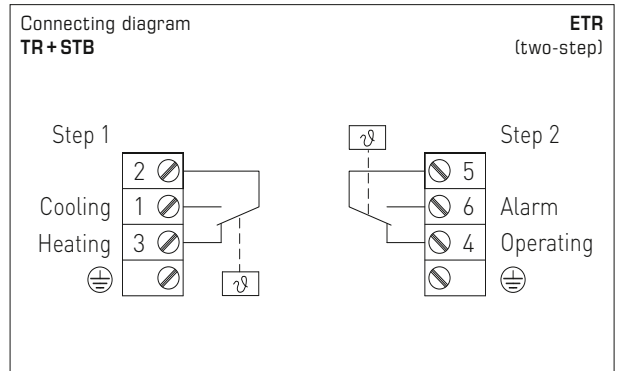
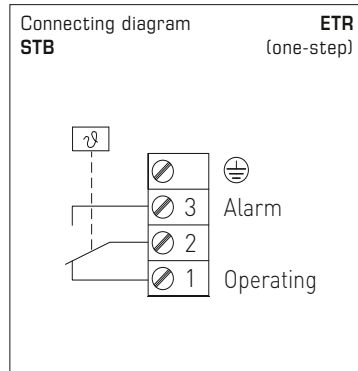
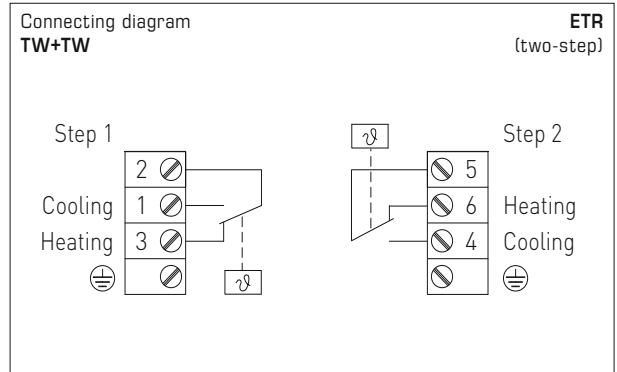
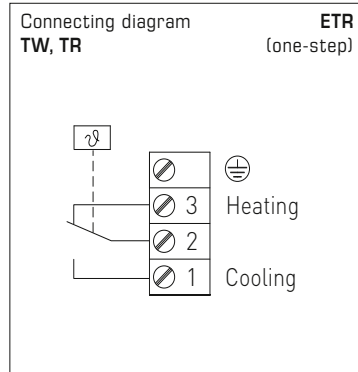

ZERTIFIKAT

**CERTIFICATE**  
valid until: 25.02.2028  
**ZERTIFIKAT**  
gültig bis: 25.02.2028

EU Type examination (module B) - production type - according to Directive 2014/68/EU

EU-Baumusterprüfung (Modul B) - Baumuster - nach Richtlinie 2014/68/EU

Certificate No.: **Z-IS-TAF-MUC-18-03-2652130-002**  
Zertifikat-Nr.: **Z-IS-TAF-MUC-18-03-2652130-002**

Name and address of manufacturer: **S+S Regeltechnik GmbH**  
Name und Anschrift des Herstellers: **Pirnaer Str. 20  
90411 Nürnberg**

We herewith certify that the type mentioned below meets the requirements of the Directive 2014/68/EU.

Hiermit wird bescheinigt, dass das unten genannte Baumuster die Anforderungen der Richtlinie 2014/68/EU erfüllt

Evaluation report No.: **C-T 1382-01/18 dated 2018-02-26**  
Prüfbericht Nr.: **C-T 1382-01/18 dated 2018-02-26**

Scope of examination: **Safety temperature limiter as safety accessory**  
Geltungsbereich: **type: ETR and KTR (see page 3)  
basis of examination and details see page 3**

Manufacturing plant: **S+S Regeltechnik GmbH**  
Fertigungsstätte: **Pirnaer Str. 20  
90411 Nürnberg**

München, 26.02.2018  
(Place, date)

Notified Body, No. 0238  
notifiziertes Stelle, Kennnummer 0238  
TUV SUD Industrie Service GmbH  
Wiederstraße: 199  
80689 München  
GERMANY

**TÜV SÜD Industrie Service GmbH**  
Certification Body for pressure equipment

*Johannes Steigelmeyer*  
Johannes Steigelmeyer

089 5190-1027  
fscert@tuev-sud.de

Page 1 of the certificate No. / Seite 1 zum Zertifikat Nr. Z-IS-TAF-MUC-18-03-2652130-002

**page 3 of certificate no. IS-TAF-MUC-18-03-2652130-002**

Replaces certificate dated:  
IS-TAF-MUC 08 02 100248356 001  
Basis of examination:  
VdTUV-Merkblatt Temperatur 100:2017-03  
DIN EN 14597 :2015-01  
Essential safety requirements of Directive 2014/68/EU

**Type code**

Type	Code	Technical data
ETR-R6585	STB	Range: from 65 °C to 85 °C
ETR-R90110	STB	Range: from 90 °C to 110 °C
KTR-R6585	STB	Same function as ETR R6585, with the following difference: The tube is not closed to the medium.
KTR-R90110	STB	Same function as ETR R90110, with the following difference: The tube is not closed to the medium.

Type	Code	Technical data
ETR-060R85	TR/STB	Combination of two single types: TR and STB with the range: TR: from 0 °C to +60 °C STB: from +65 °C to + 85°
ETR-090R110	TR/STB	Combination of two single types: TR and STB with the range: TR: from 0 °C to +90 °C STB: from +90 °C to + 110°
KTR-060R85	TR/STB	Same function as ETR-060R85, with the following difference: The tube is not closed to the medium
KTR-090R110	TR/STB	Same function as ETR-090R110, with the following difference: The tube is not closed to the medium

**The conditions listed below have to be considered:**

- To keep the specified response time the types ETR... shall be used with the provided tube and thermal conducting paste
- Possible risks caused by external fire or by traffic, wind and earthquake loading shall be examined separately depending from the installation situation of the pressure equipment

Appendix of certificate / Anlage zum Zertifikat Z-IS-TAF-MUC-18-03-2652130-002

one-step

Equipment sensor / controller, including immersion sleeve,  
EC type-tested, TÜV tested,  
with switching output

Dimensional drawing  
Temperature monitor  
**TW**

**ETR-xx U**  
(one-step)

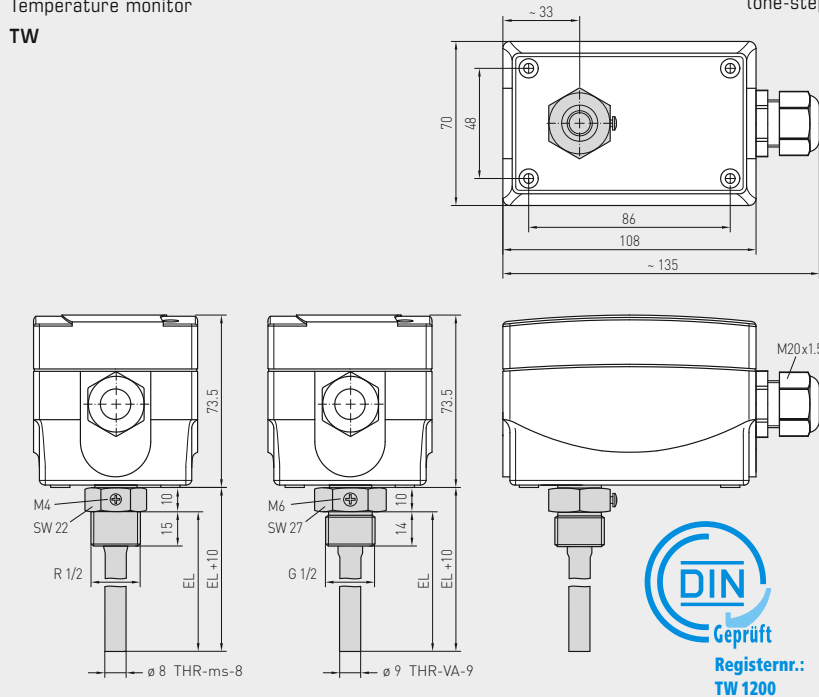

**ETR-060 U**  
**ETR-090 U**  
(one-step)  
**TW**

Dimensional drawing  
Temperature controller  
**TR**

**ETR-xx**  
(one-step)

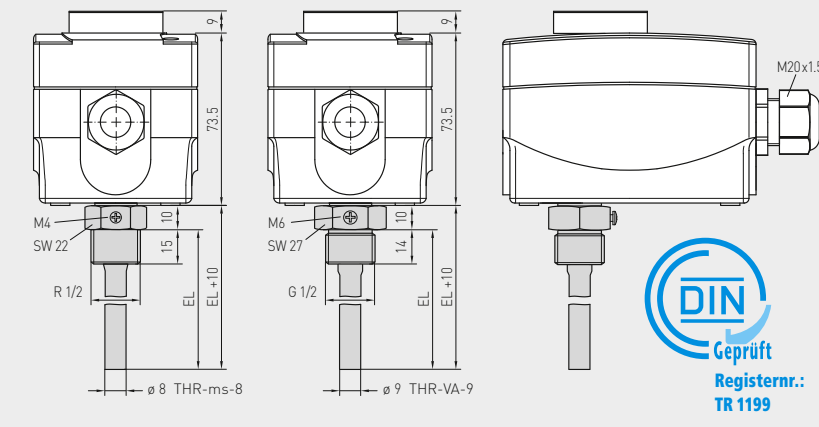

**ETR-1**  
**ETR-060**  
**ETR-090**  
**ETR-0120**  
**ETR-50140**  
(one-step)  
**TR**

Dimensional drawing  
Safety temperature limiter  
**STB**

**ETR-Rxx**  
(one-step)

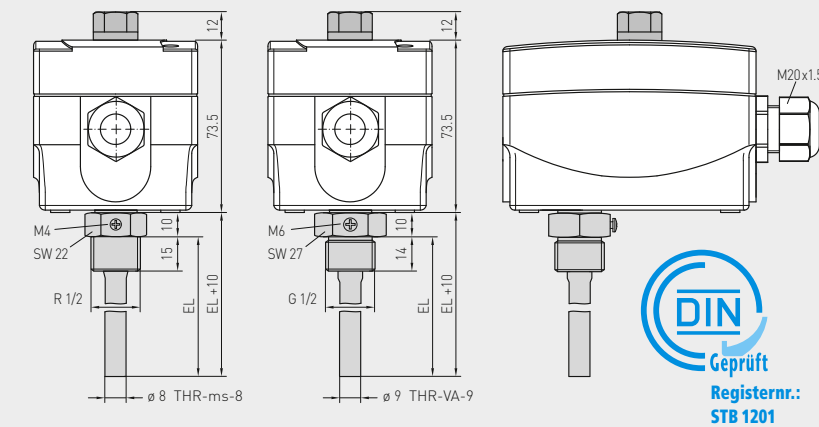

**ETR-R6585**  
**ETR-R90110**  
(one-step)  
**STB**  
selectable



## THERMASREG® ETR Equipment sensor / controller, one-step, including immersion sleeve

Type / WG02	Inserted Length (EL)	Temperature Ranges (adjustable)	Thermal Operating Difference (fixed) approx.	Maximum Capillary Temp.	Item No.	Price
<b>ETR-060 U</b>						<b>TW</b>
ETR-060 U MS/100	100 mm	0...+60 °C	3K	+75 °C	1102-2010-2100-380	67,46 €
ETR-060 U MS/150	150 mm	0...+60 °C	3K	+75 °C	1102-2010-2100-310	69,72 €
ETR-060 U MS/200	200 mm	0...+60 °C	3K	+75 °C	1102-2010-2100-320	73,71 €
ETR-060 U VA/100	100 mm	0...+60 °C	3K	+75 °C	1102-2010-2100-390	93,77 €
ETR-060 U VA/150	150 mm	0...+60 °C	3K	+75 °C	1102-2010-2100-330	96,02 €
ETR-060 U VA/200	200 mm	0...+60 °C	3K	+75 °C	1102-2010-2100-340	100,03 €
<b>ETR-090 U</b>						<b>TW</b>
ETR-090 U MS/100	100 mm	0...+90 °C	3K	+120 °C	1102-2010-2100-480	67,46 €
ETR-090 U MS/150	150 mm	0...+90 °C	3K	+120 °C	1102-2010-2100-410	69,72 €
ETR-090 U MS/200	200 mm	0...+90 °C	3K	+120 °C	1102-2010-2100-420	73,71 €
ETR-090 U VA/100	100 mm	0...+90 °C	3K	+120 °C	1102-2010-2100-490	93,77 €
ETR-090 U VA/150	150 mm	0...+90 °C	3K	+120 °C	1102-2010-2100-430	96,02 €
ETR-090 U VA/200	200 mm	0...+90 °C	3K	+120 °C	1102-2010-2100-440	100,03 €
<b>ETR-1</b>						<b>TR</b>
ETR-1 MS/100	100 mm	-35...+35 °C	3K	+75 °C	1102-2010-1100-180	67,46 €
ETR-1 MS/150	150 mm	-35...+35 °C	3K	+75 °C	1102-2010-1100-110	69,72 €
ETR-1 MS/200	200 mm	-35...+35 °C	3K	+75 °C	1102-2010-1100-120	73,71 €
ETR-1 VA/100	100 mm	-35...+35 °C	3K	+75 °C	1102-2010-1100-190	93,77 €
ETR-1 VA/150	150 mm	-35...+35 °C	3K	+75 °C	1102-2010-1100-130	96,02 €
ETR-1 VA/200	200 mm	-35...+35 °C	3K	+75 °C	1102-2010-1100-140	100,03 €
<b>ETR-060</b>						<b>TR</b>
ETR-060 MS/100	100 mm	0...+60 °C	3K	+75 °C	1102-2010-1100-380	67,46 €
ETR-060 MS/150	150 mm	0...+60 °C	3K	+75 °C	1102-2010-1100-310	69,72 €
ETR-060 MS/200	200 mm	0...+60 °C	3K	+75 °C	1102-2010-1100-320	73,71 €
ETR-060 VA/100	100 mm	0...+60 °C	3K	+75 °C	1102-2010-1100-390	93,77 €
ETR-060 VA/150	150 mm	0...+60 °C	3K	+75 °C	1102-2010-1100-330	96,02 €
ETR-060 VA/200	200 mm	0...+60 °C	3K	+75 °C	1102-2010-1100-340	100,03 €
<b>ETR-090</b>						<b>TR</b>
ETR-090 MS/100	100 mm	0...+90 °C	3K	+120 °C	1102-2010-1100-480	67,46 €
ETR-090 MS/150	150 mm	0...+90 °C	3K	+120 °C	1102-2010-1100-410	69,72 €
ETR-090 MS/200	200 mm	0...+90 °C	3K	+120 °C	1102-2010-1100-420	73,71 €
ETR-090 VA/100	100 mm	0...+90 °C	3K	+120 °C	1102-2010-1100-490	93,77 €
ETR-090 VA/150	150 mm	0...+90 °C	3K	+120 °C	1102-2010-1100-430	96,02 €
ETR-090 VA/200	200 mm	0...+90 °C	3K	+120 °C	1102-2010-1100-440	100,03 €
<b>ETR-0120</b>						<b>TR</b>
ETR-0120 MS/100	100 mm	0...+120 °C	5K	+135 °C	1102-2010-1100-580	67,46 €
ETR-0120 MS/150	150 mm	0...+120 °C	5K	+135 °C	1102-2010-1100-510	69,72 €
ETR-0120 MS/200	200 mm	0...+120 °C	5K	+135 °C	1102-2010-1100-520	73,71 €
ETR-0120 VA/100	100 mm	0...+120 °C	5K	+135 °C	1102-2010-1100-590	93,77 €
ETR-0120 VA/150	150 mm	0...+120 °C	5K	+135 °C	1102-2010-1100-530	96,02 €
ETR-0120 VA/200	200 mm	0...+120 °C	5K	+135 °C	1102-2010-1100-540	100,03 €
<b>ETR-50140</b>						<b>TR</b>
ETR-50140 MS/100	100 mm	+50...+140 °C	5K	+150 °C	1102-2010-1100-680	67,46 €
ETR-50140 MS/150	150 mm	+50...+140 °C	5K	+150 °C	1102-2010-1100-610	69,72 €
ETR-50140 MS/200	200 mm	+50...+140 °C	5K	+150 °C	1102-2010-1100-620	73,71 €
ETR-50140 VA/100	100 mm	+50...+140 °C	5K	+150 °C	1102-2010-1100-690	93,77 €
ETR-50140 VA/150	150 mm	+50...+140 °C	5K	+150 °C	1102-2010-1100-630	96,02 €
ETR-50140 VA/200	200 mm	+50...+140 °C	5K	+150 °C	1102-2010-1100-640	100,03 €
<b>ETR-R6585</b>						<b>STB</b>
ETR-R6585 MS/100	100 mm	+65...+85 °C	+0 / -15...20 K	+120 °C	1102-2010-6100-780	81,29 €
ETR-R6585 MS/150	150 mm	+65...+85 °C	+0 / -15...20 K	+120 °C	1102-2010-6100-710	83,55 €
ETR-R6585 MS/200	200 mm	+65...+85 °C	+0 / -15...20 K	+120 °C	1102-2010-6100-720	91,18 €
ETR-R6585 VA/100	100 mm	+65...+85 °C	+0 / -15...20 K	+120 °C	1102-2010-6100-790	98,49 €
ETR-R6585 VA/150	150 mm	+65...+85 °C	+0 / -15...20 K	+120 °C	1102-2010-6100-730	100,74 €
ETR-R6585 VA/200	200 mm	+65...+85 °C	+0 / -15...20 K	+120 °C	1102-2010-6100-740	104,88 €
<b>ETR-R90110</b>						<b>STB</b>
ETR-R90110 MS/100	100 mm	+90...+110 °C	+0 / -15...20 K	+120 °C	1102-2010-6100-880	81,29 €
ETR-R90110 MS/150	150 mm	+90...+110 °C	+0 / -15...20 K	+120 °C	1102-2010-6100-810	83,55 €
ETR-R90110 MS/200	200 mm	+90...+110 °C	+0 / -15...20 K	+120 °C	1102-2010-6100-820	91,18 €
ETR-R90110 VA/100	100 mm	+90...+110 °C	+0 / -15...20 K	+120 °C	1102-2010-6100-890	98,49 €
ETR-R90110 VA/150	150 mm	+90...+110 °C	+0 / -15...20 K	+120 °C	1102-2010-6100-830	100,74 €
ETR-R90110 VA/200	200 mm	+90...+110 °C	+0 / -15...20 K	+120 °C	1102-2010-6100-840	104,88 €

Type designation:

ETR-xx\_immersion sleeve material / inserted length (mm)

MS = Brass nickel-plated, VA = Stainless steel V4A (1.4571)

For further information and accessories see next page...

Dimensional drawing  
Double temperature monitor  
TW + TW

ETR-xx U  
(two-step)

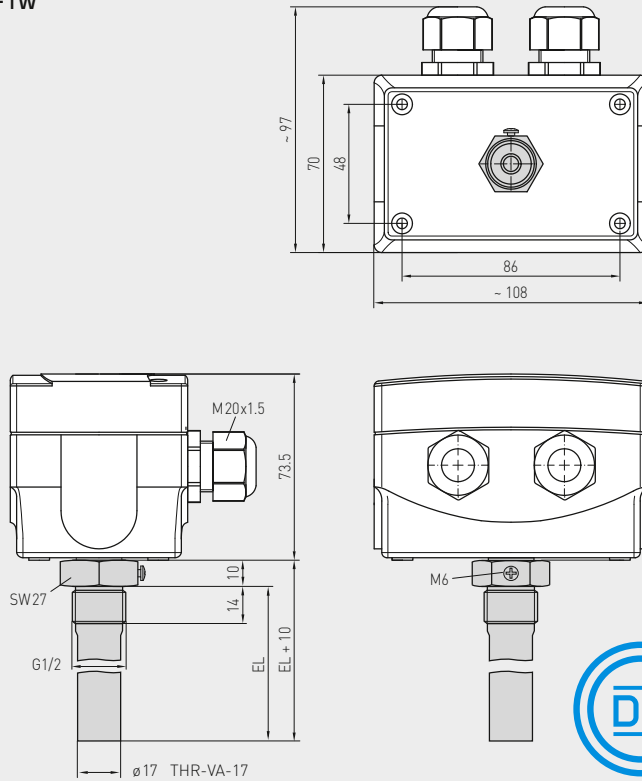

Registernr.:  
TW / TW 1241



ETR-090090 U  
(two-step)  
TW + TW

Dimensional drawing  
Temperature controller +  
safety temperature limiter  
TR + STB

ETR-xx Rxx  
(two-step)

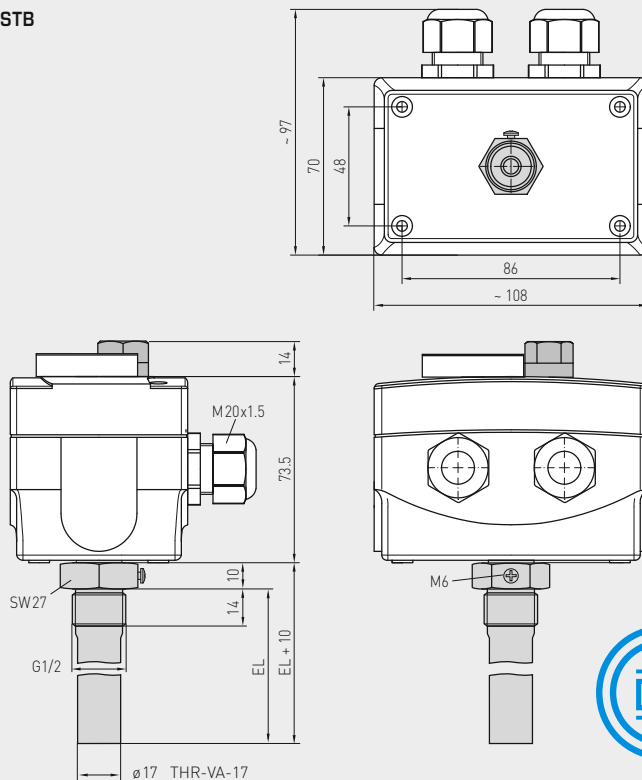

Registernr.:  
TR / STB 1202



ETR-060 R 85  
ETR-090 R 110  
(two-step)  
TR + STB  
selectable



**THERMASREG® ETR** Equipment sensor / controller, two-step, including immersion sleeve

Type / WG02	Inserted Length (EL)	Temperature Ranges (adjustable)		Thermal Operating Difference (fixed) approx.		Maximum Capillary Temp.	Item No.	Price
		1.	2.	1.	2.			
<b>ETR-090090 U</b>								<b>TW + TW</b>
ETR-090090 U VA/150	150 mm	0...+90 °C	0...+90 °C	3K	3K	+120 °C	1102-2010-2205-130	139,44 €
ETR-090090 U VA/200	200 mm	0...+90 °C	0...+90 °C	3K	3K	+120 °C	1102-2010-2205-140	151,56 €
<b>ETR-060R85</b>								<b>TR + STB</b>
ETR-060R85 VA/150	150 mm	0...+60 °C	+65...+85 °C	3K	+0/-15...20K	+120 °C	1102-2010-7205-230	139,44 €
ETR-060R85 VA/200	200 mm	0...+60 °C	+65...+85 °C	3K	+0/-15...20K	+120 °C	1102-2010-7205-240	151,56 €
<b>ETR-090R110</b>								<b>TR + STB</b>
ETR-090R110 VA/150	150 mm	0...+90 °C	+90...+110 °C	3K	+0/-15...20K	+135 °C	1102-2010-7205-330	139,44 €
ETR-090R110 VA/200	200 mm	0...+90 °C	+90...+110 °C	3K	+0/-15...20K	+135 °C	1102-2010-7205-340	151,56 €

Type designation:	<b>ETR-xx_immersion sleeve material / inserted length (mm)</b> MS = Brass nickel-plated, VA = Stainless steel V4A (1.4571)		
Extra charge:	U = Internal setting, unless included in a certain type /2 = 2 steps, unless included in a certain type		9,48 € on request
Features:	<b>TR</b> = Temperature controller ( <b>external setting</b> ) <b>TW</b> = Temperature monitor ( <b>internal setting</b> ) <b>STB</b> = Safety temperature limiter ( <b>internal setting</b> ), <b>selectable</b> , with external switchpoint confirmation and restart interlock, restart by reset button at approx. 15...20K below switching temperature (+0K / - 15...20K); <b>with EC type test (module B) according to directive 2014 / 68 / EU</b>		
Note:	To ensure <b>accurate responsiveness</b> series ETR devices must only be used in connection with the immersion sleeves included in the scope of delivery while applying heat-conductive paste		

**ACCESSORIES**

<b>WLP-1</b>	<b>Heat-conductive paste</b> , silicone-free	7100-0060-1000-000	<b>3,22 €</b>
--------------	--	--------------------	---------------

For further information see last chapter!

**THERMASGARD® THR** Immersion sleeve Ø 8 / 9 / 17 mm

Type / WG01	p <sub>max</sub> (static)	T <sub>max</sub>	Time Constant for Medium:			Inserted Length (EL)	Item No. Ø	Price
			Air	Water	Oil			
<b>THR-ms-08 / xx</b> Brass nickel-plated Ø 8 x 0.5 mm								
THR-MS-08/100	10 bar	+150 °C	106 s	18 s	53 s	100 mm	7100-0011-3022-000	14,69 €
THR-MS-08/150	10 bar	+150 °C	106 s	18 s	53 s	150 mm	7100-0011-3404-000	14,81 €
THR-MS-08/200	10 bar	+150 °C	106 s	18 s	53 s	200 mm	7100-0011-3403-000	17,59 €
<b>THR-VA-09 / xx</b> Stainless steel V4A (1.4571) Ø 9 x 1.0 mm								
THR-VA-09/100	25 bar	+150 °C	92 s	17 s	41 s	100 mm	7100-0012-3022-000	37,83 €
THR-VA-09/150	25 bar	+150 °C	92 s	17 s	41 s	150 mm	7100-0012-3032-000	39,04 €
THR-VA-09/200	25 bar	+150 °C	92 s	17 s	41 s	200 mm	7100-0012-3042-000	41,83 €
<b>THR-VA-17 / xx</b> Stainless steel V4A (1.4571) Ø 17 x 1.0 mm								
THR-VA-17/150	25 bar	+150 °C	-	45 s	55 s	150 mm	7100-0012-3033-000	39,04 €
THR-VA-17/200	25 bar	+150 °C	-	45 s	55 s	200 mm	7100-0012-3404-000	41,83 €

Ordering example:	THR - ms - 08 / 100 (Brass immersion sleeve, Ø = 8 mm, EL = 100 mm)
	THR - VA - 09 / 150 (Stainless steel immersion sleeve, Ø = 9 mm, EL = 150 mm)
	THR - VA - 17 / 200 (Stainless steel immersion sleeve, Ø = 17 mm, EL = 200 mm)

Note: inner diameter of socket 15.0 mm



Duct temperature controllers, including mounting flange,  
EC type-tested, TÜV tested,  
with switching output

DIN-tested German quality product. Temperature control and limiting device for heat generation plants in accordance with DIN EN 14597. Safety temperature limiter (STB) with EC type test (module B) according to directive 2014 / 68 / EU.

Mechanical temperature control device / rod thermostat THERMASREG® KTR with switching output, used for monitoring, controlling or limiting the temperatures of gaseous media as a boiler controller or in heating, air conditioning technology as well as in mechanical and apparatus engineering and in heat generation plants. It is available as one-step or two-step device, as adjustable temperature controller TR, temperature monitor TW, or as safety temperature limiter STB.



**TECHNICAL DATA**

Switching capacity: (Contact load)	24...250V AC +10%, 10A, cos φ = 1.0 24...250V AC +10%, 1.5A, cos φ = 0.6 at 24V AC min. 150mA
Contact:	dust-proof switch block unit as potential-free, single-pole or two-pole changeover contact
Housing:	plastic, UV-resistant, material polyamide, 30% glass-globe reinforced, colour traffic white (similar to RAL 9016)
Housing dimensions:	108 x 70 x 73.5 mm (Thor 2)
Cable gland:	M20 x 1.5; including strain relief
Measuring element:	torsion meter with liquid filling, liquid expansion temperature feeler
Mounting position:	arbitrary
Ambient temperature:	-10...+65 °C at the switch block housing
Tolerance:	T <sub>min</sub> ± 5 K; T <sub>max</sub> ± 3 K
Operating medium:	Air
Protective tube:	<b>metal</b> , material CuZn37 (2.0321), Ø 14 mm, NL = 205 mm
Inserted length:	approx. 205 mm (with flange); approx. 184 mm (without flange)
Process connection:	by mounting flange (included in the scope of delivery)
Electrical connection:	0.14 - 2.5 mm <sup>2</sup> via terminal screws
Protection class:	I (according to EN 60 730)
Protection type:	<b>IP 65</b> (according to EN 60 529)
Standards:	CE conformity, EMC directive 2014 / 30 / EU, low-voltage directive 2014 / 35 / EU
Tests:	<b>EC type test (module B) according to directive 2014 / 68 / EU</b> , certificate No.: IS-TAF-MUC 18 03 2652130 002, DIN EN 14597, register Nos.: <b>STB 1201, TR / STB 1202</b>

<b>FUNCTION</b>	<b>TW, TR:</b> Contact 2 - 3 breaks when temperature rises to the preset value.
	<b>STB:</b> Contact 2 - 1 or 5 - 4 (two-step) breaks when temperature rises to the preset value. Restart is possible only after cooling off by approx. 15 K - 20 K by pressing the reset button.





Configuration variants:

- TW**  
Temperature monitor  
(internal setting)
- TR**  
Temperature controller  
(external setting)
- STB**  
Safety temperature limiter  
(internal setting)
- TW+TW**  
Double temperature monitor  
(internal setting)
- TR + STB**  
Temperature controller  
(external setting) +  
Safety temperature limiter  
(internal setting)

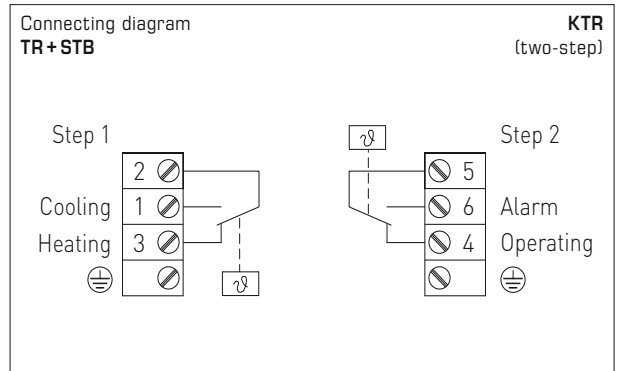
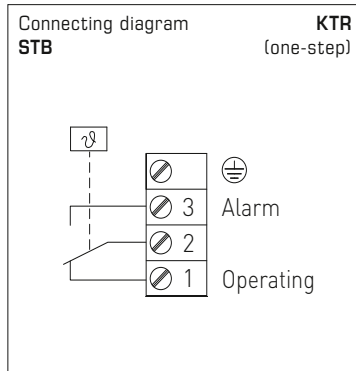
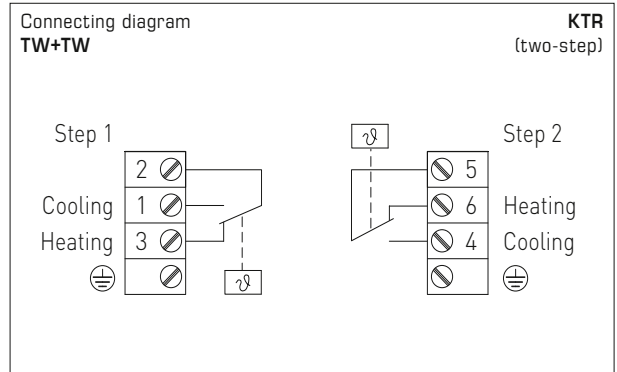
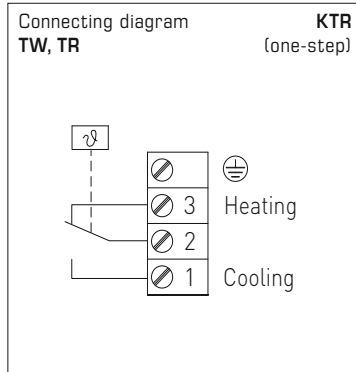

ZERTIFIKAT



**CERTIFICATE**  
valid until: 25.02.2028  
**ZERTIFIKAT**  
gültig bis: 25.02.2028

EU Type examination (module B) - production type - according to Directive 2014/68/EU  
EU-Baumusterprüfung (Modul B) - Baumuster - nach Richtlinie 2014/68/EU

Certificate No.: **Z-IS-TAF-MUC-18-03-2652130-002**  
Zertifikat-Nr.:

Name and address of manufacturer: **S+S Regeltechnik GmbH**  
Name und Anschrift des Herstellers: **Pirnaer Str. 20, 90411 Nürnberg**

We herewith certify that the type mentioned below meets the requirements of the Directive 2014/68/EU.  
Nimmt wird bescheinigt, dass das unten genannte Baumuster die Anforderungen der Richtlinie 2014/68/EU erfüllt.

Evaluation report No.: **C-T 1382-01/18 dated 2018-02-26**  
Prüfbericht Nr.:

Scope of examination: **Safety temperature limiter as safety accessory**  
Geltungsbereich: **type: ETR and KTR (see page 3) basis of examination and details see page 3**

Manufacturing plant: **S+S Regeltechnik GmbH**  
Fertigungsstätte: **Pirnaer Str. 20, 90411 Nürnberg**

München, 26.02.2018  
(Place, date)  
(Ort, Datum)

Verification of Certificate by TÜV SÜD App Verify  
Erstbescheinigung durch App TÜV SÜD Verify

Notified Body, No. 0238  
Notifiziertes Stelle, Kennnummer 0238  
TÜV SÜD Industrie Service GmbH  
Wiederstraße 199  
80688 München  
GERMANY

**TÜV SÜD Industrie Service GmbH**  
Certification Body for pressure equipment



Johannes Steigelmeyer

089 5190-1027  
fscert@tuev-sud.de



Page 1 of the certificate No. / Seite 1 zum Zertifikat Nr. Z-IS-TAF-MUC-18-03-2652130-002

ZERTIFIKAT



page 3 of certificate no. IS-TAF-MUC-18-03-2652130-002

Reference certificate dated:  
IS-TAF-MUC 08 02 100248356 001  
Basis of examination:  
VdTÜV-Merkblatt Temperatur 100:2017-03  
DIN EN 14597 :2015-01  
Essential safety requirements of Directive 2014/68/EU

**Type code**

Type	Code	Technical data
ETR-R6585	STB	Range: from 65 °C to 85 °C
ETR-R90110	STB	Range: from 90 °C to 110 °C
KTR-R6585	STB	Same function as ETR R6585, with the following difference: The tube is not closed to the medium.
KTR-R90110	STB	Same function as ETR R90110, with the following difference: The tube is not closed to the medium.

Type	Code	Technical data
ETR-060R85	TR/STB	Combination of two single types: TR and STB with the range: TR: from 0 °C to +60 °C STB: from +65 °C to + 85°
ETR-090R110	TR/STB	Combination of two single types: TR and STB with the range: TR: from 0 °C to +90 °C STB: from +90 °C to + 110°
KTR-060R85	TR/STB	Same function as ETR-060R85, with the following difference: The tube is not closed to the medium
KTR-090R110	TR/STB	Same function as ETR-090R110, with the following difference: The tube is not closed to the medium

**The conditions listed below have to be considered:**

- 1 To keep the specified response time the types ETR... shall be used with the provided tube and thermal conducting paste
- 2 Possible risks caused by external fire or by traffic, wind and earthquake loading shall be examined separately depending from the installation situation of the pressure equipment

Appendix of certificate / Anlage zum Zertifikat Z-IS-TAF-MUC-18-03-2652130-002

Dimensional drawing  
Temperature monitor

TW

KTR-xxU  
(one-step)

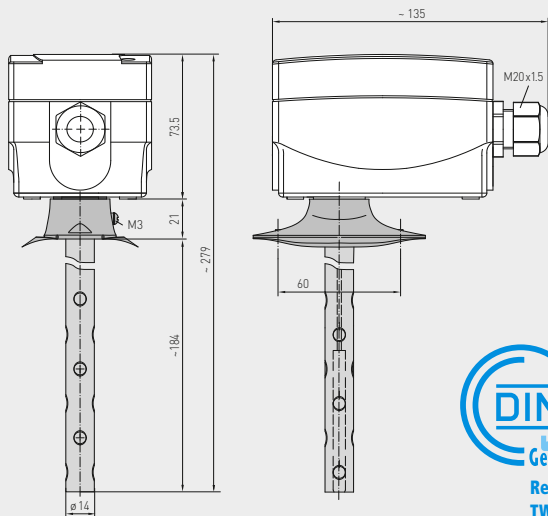

KTR-060U  
KTR-090U  
(one-step)  
TW

Dimensional drawing  
Temperature controller

TR

KTR-xx  
(one-step)

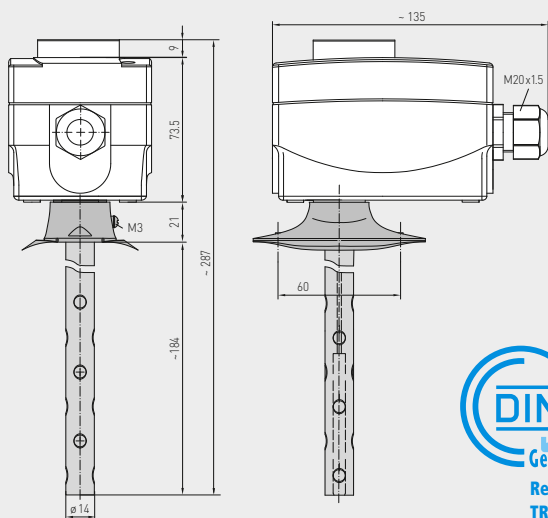

KTR-1  
KTR-060  
KTR-090  
KTR-0120  
KTR-50140  
(one-step)  
TR

Dimensional drawing  
Safety temperature limiter

STB

KTR-Rxx  
(one-step)

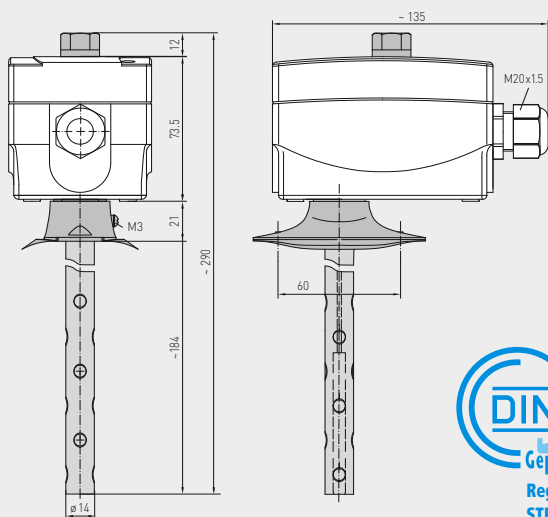

KTR-R6585  
KTR-R90110  
(one-step)  
STB  
adjustable





THERMASREG® KTR Duct temperature controllers, one-step						
Type / WG02	Ø mm	Temperature Ranges (adjustable)	Thermal Operating Difference (fixed) approx.	Maximum Capillary Temp.	Item No.	Price
<b>KTR-060 U / 090 U</b>					<b>TW</b>	
KTR-060 U	14	0...+60 °C	3K	+75 °C	1102-3010-2100-350	<b>72,86 €</b>
KTR-090 U	14	0...+90 °C	3K	+120 °C	1102-3010-2100-450	<b>72,86 €</b>
<b>KTR-xx</b>					<b>TR</b>	
KTR-1	14	-35...+35 °C	3K	+75 °C	1102-3010-1100-150	<b>72,86 €</b>
KTR-060	14	0...+60 °C	3K	+75 °C	1102-3010-1100-350	<b>72,86 €</b>
KTR-090	14	0...+90 °C	3K	+120 °C	1102-3010-1100-450	<b>72,86 €</b>
KTR-0120	14	0...+120 °C	5K	+135 °C	1102-3010-1100-550	<b>72,86 €</b>
KTR-50140	14	+50...+140 °C	5K	+150 °C	1102-3010-1100-650	<b>72,86 €</b>
<b>KTR-R6585 / R90110</b>					<b>STB</b>	
KTR-R6585	14	+65...+85 °C	+0 / -15...20K	+120 °C	1102-3010-6100-750	<b>86,38 €</b>
KTR-R90110	14	+90...+110 °C	+0 / -15...20K	+120 °C	1102-3010-6100-850	<b>86,38 €</b>
Extra charge:	<b>U</b>	= Internal setting, unless included in a certain type				<b>9,48 €</b>
	<b>/2</b>	= 2 steps, unless included in a certain type				on request
Equipment:	<b>FT</b>	= Manual reset when temperature drops				
	<b>ST</b>	= Manual reset when temperature rises				
	<b>TR</b>	= Temperature controller ( <b>external setting</b> )				
	<b>TB</b>	= Temperature limiter ( <b>internal setting</b> )				
	<b>TW</b>	= Temperature monitor ( <b>internal setting</b> )				
	<b>STB</b>	= Safety temperature limiter ( <b>internal setting</b> ), <b>selectable</b> , with external switchpoint confirmation and restart interlock, restart by reset button at approx. 15...20 K below switching temperature (+ 0 K / - 15...20 K) <b>with EC type test (module B) according to directive 2014 / 68 / EU</b>				

ACCESSORIES			
<b>MF-14-K</b>	<b>Mounting flange, plastic</b>	7100-0030-2000-000	<b>9,10 €</b>
For further information see last chapter!			

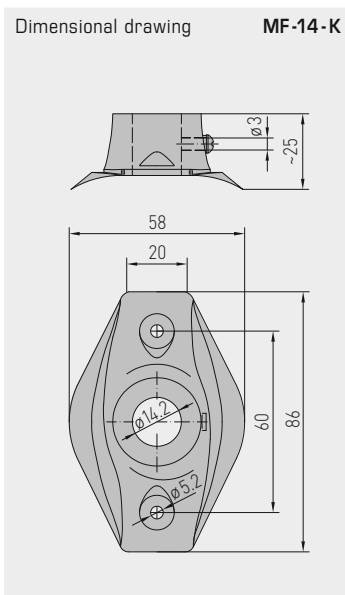

**MF-14-K**  
Mounting flange,  
plastic



Dimensional drawing  
Double temperature monitor  
TW + TW

**KTR-xxU**  
(two-step)

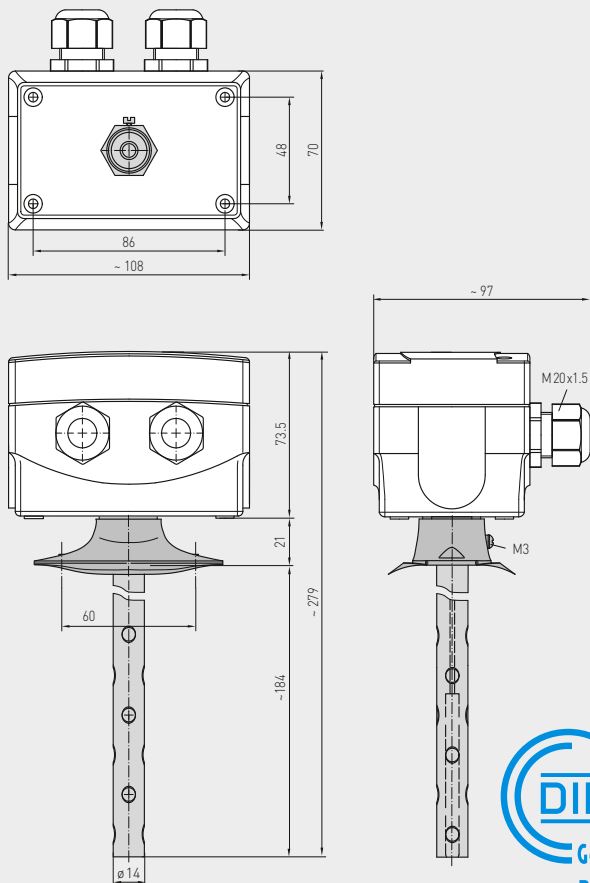

**KTR-090090U**  
(two-step)  
TW + TW

Dimensional drawing  
Temperature controller +  
safety temperature limiter  
TR + STB

**KTR-xxRxx**  
(two-step)

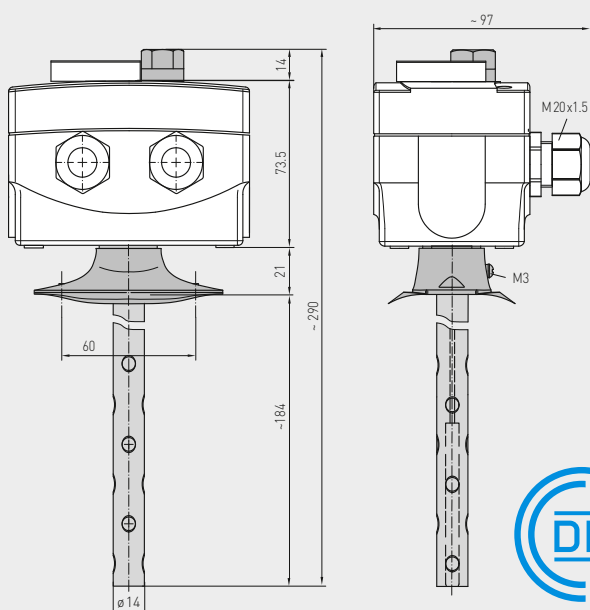

**KTR-060R85**  
**KTR-090R110**  
(two-step)  
TR + STB  
adjustable





THERMASREG® KTR Duct temperature controllers, two-step								
Type / WG02	Ø mm	Temperature Ranges (adjustable)		Thermal Operating Difference (fixed) approx.		Maximum Capillary Temp.	Item No.	Price
		1.	2.	1.	2.			
<b>KTR-090090 U</b>							<b>TW+TW</b>	
KTR-090090 U	14	0...+90°C	0...+90°C	3K	3K	+120°C	1102-3010-2205-150	<b>108,33 €</b>
<b>KTR-060R85</b>							<b>TR+STB</b>	
KTR-060R85	14	0...+60°C	+65...+85°C	3K	+0/-15...20K	+120°C	1102-3010-7205-250	<b>108,33 €</b>
<b>KTR-090R110</b>							<b>TR+STB</b>	
KTR-090R110	14	0...+90°C	+90...+110°C	3K	+0/-15...20K	+135°C	1102-3010-7205-350	<b>108,33 €</b>
Extra charge:	<b>U</b> = Internal setting, unless included in a certain type <b>/2</b> = <b>2 steps, unless included in a certain type</b>						on request	<b>9,48 €</b>
Features:	<b>TR</b> = Temperature controller ( <b>external setting</b> ) <b>TW</b> = Temperature monitor ( <b>internal setting</b> ) <b>STB</b> = Safety temperature limiter ( <b>internal setting</b> ), <b>selectable</b> , with external switchpoint confirmation and restart interlock, restart by reset button at approx. 15...20 K below switching temperature (+ 0 K / - 15...20 K) <b>with EC type test (module B) according to directive 2014/68/EU</b>							

ACCESSORIES			
<b>MF-14-K</b>	<b>Mounting flange, plastic</b>	7100-0030-2000-000	<b>9,10 €</b>
For further information see last chapter!			

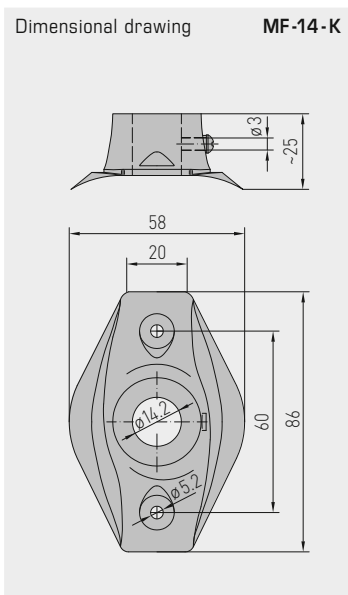

**MF-14-K**  
Mounting flange,  
plastic



**Surface contact temperature controllers, including tension spring**

Mechanical temperature controllers / contact thermostats **THERMASREG® ALTR** with switching output (two-position controller) for monitoring, controlling and limitation of temperatures at pipes or vessels, e.g. in connection with hot-water or floor heating systems. The contact temperature controller ALTR is built as one-step device, as adjustable temperature controller **TR** (with external setting) or as adjustable temperature monitor **TW** (with internal setting).

**TECHNICAL DATA**

Switching capacity: (Contact load)	16 (4) A; 24...250 V AC at 24 V AC min. 150 mA
Max. sensor temperature:	+110 °C
Contact:	dust-proof switch block unit as potential-free single-pole changeover contact
Housing:	ABS (acrylonitrile butadiene styrene), fibre-glass reinforced, base: steel, galvanised, top: grey, M 16 x 1.5
Housing temperature:	-35...+65 °C
Tolerance:	T <sub>min</sub> ± 5 K; T <sub>max</sub> ± 5 K
Sensor element:	bi-metal
Housing dimensions:	38 x 48 x 103 mm
Process connection:	by metal tension spring, 220 mm long (included in the scope of delivery)
Electrical connection:	0.14 - 1.5 mm <sup>2</sup> via terminal screws
Protection class:	I (according to EN 60 730)
Protection type:	<b>IP 40</b> (according to EN 60 529)
Standards:	CE conformity, EMC directive 2014 / 30 / EU, low-voltage directive 2014 / 35 / EU

**FUNCTION**      **Heating:** wire contacts C - 1  
**Cooling:** wire contacts C - 2

Dimensional drawing

ALTR 060 / 090

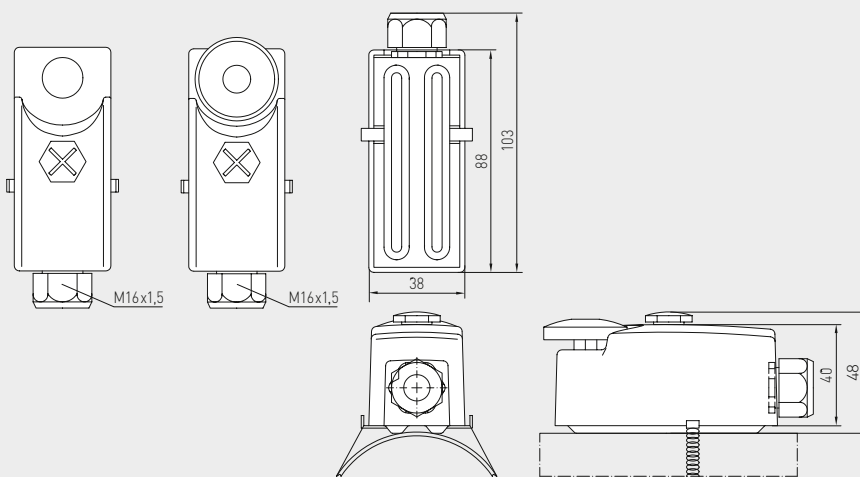

Connecting diagram ALTR 060 / 090

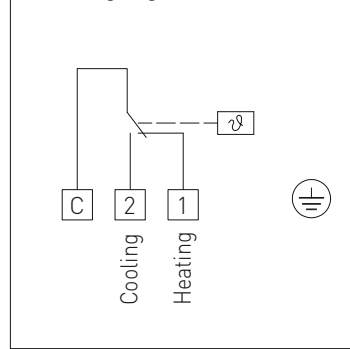

ALTR 060 / 090



ALTR 060 / 090 U



**THERMASREG® ALTR 060 / 090** Surface contact temperature controllers

Type / WG01	Temperature Range	Thermal Operating Difference (fixed) approx.	Max. Capillary Temperature	Item No.	Price
<b>ALTR 060 / 090</b>					<b>TR</b> (External setting)
ALTR-060	0...+60 °C	8 K (± 1 K)	+110 °C	1102-1040-1100-300	<b>30,32 €</b>
ALTR-090	0...+90 °C	8 K (± 1 K)	+110 °C	1102-1040-1100-400	<b>30,32 €</b>
<b>ALTR 060 / 090 U</b>					<b>TW</b> (Internal setting)
ALTR-060 U	0...+60 °C	8 K (± 1 K)	+110 °C	1102-1040-2100-300	<b>30,32 €</b>
ALTR-090 U	0...+90 °C	8 K (± 1 K)	+110 °C	1102-1040-2100-400	<b>30,32 €</b>



Mechanical temperature controllers / contact thermostats **THERMASREG® ALTR** with switching output (two-position controller) for monitoring, controlling and limitation of temperatures at pipes or vessels, e.g. in connection with hot-water or floor heating systems. The contact temperature controller ALTR is built as one-step device, as adjustable temperature controller **TR** (with external setting) or as adjustable temperature monitor **TW** (with internal setting).

**TECHNICAL DATA**

Switching capacity:	24 ... 250 V AC + 10%, 16 A, cos φ = 1.0 (Contact load) 24 ... 250 V AC + 10%, 1.5 A, cos φ = 0.6 at 24 V AC min. 150 mA
Contact:	dust-proof switch block unit as potential-free single-pole changeover contact
Housing:	plastic, UV-resistant, material polyamide, 30% glass-globe reinforced, colour traffic white (similar to RAL 9016)
Housing dimensions:	108 x 70 x 73.5 mm (Thor 2)
Cable gland:	M20 x 1.5; including strain relief
Housing temperature:	-35...+65 °C
Tolerance:	T <sub>min</sub> ± 5 K; T <sub>max</sub> ± 5 K
Design principle:	torsion meter with liquid filling
Process connection:	endless strap with metal tightener (included in the scope of delivery), Ø = 13 - 92 mm (¼ - 3"), L = 300 mm
Electrical connection:	0.14 - 2.5 mm <sup>2</sup> via terminal screws
Protection class:	I (according to EN 60 730)
Protection type:	<b>IP 65</b> (according to EN 60 529)
Standards:	CE conformity, EMC directive 2014 / 30 / EU, low-voltage directive 2014 / 35 / EU

**FUNCTION**

**Heating:** The preset setpoint (scale value) is equivalent to the switch-off value of the heating. The switch-on value is lower by the amount of operating difference. Contact 2-3 breaks when temperature rises to the preset value.

**Cooling:** The preset setpoint (scale value) is equivalent to the switch-on value of the cooling. The switch-off value is lower by the amount of operating difference. Contact 1-2 closes when temperature rises to the preset value.



Dimensional drawing

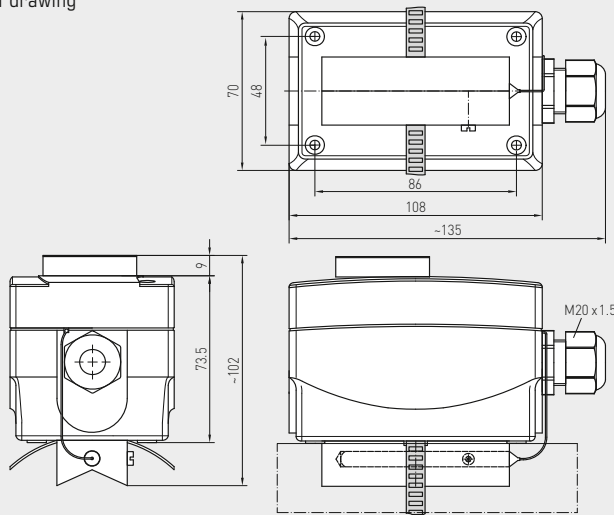

ALTR 1/3/5/7

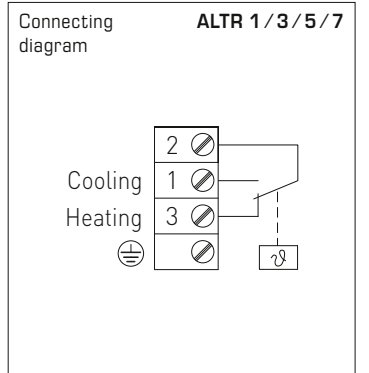

**THERMASREG® ALTR 1 / 3 / 5 / 7** Surface contact temperature controllers

Type/WG01	Temperature Range	Thermal Operating Difference (fixed) approx.	Max. Capillary Temperature	Item No.	Price
<b>ALTR 1/3/5/7</b>					
ALTR-1	-35... +35 °C	5K (± 1 K)	+60 °C	TR (External setting) 1102-1030-1100-100	<b>95,89 €</b>
ALTR-3	0... +60 °C	5K (± 1 K)	+75 °C	1102-1030-1100-300	<b>95,89 €</b>
ALTR-5	0... +90 °C	5K (± 1 K)	+120 °C	1102-1030-1100-400	<b>95,89 €</b>
ALTR-7	0... +120 °C	5K (± 1 K)	+130 °C	1102-1030-1100-500	<b>95,89 €</b>
Extra charge:	<b>U</b> = Internal setting ( <b>TW</b> ), e.g. ALTR-1 U				<b>9,48 €</b>

**Frost protection thermostats, mechanical, one-step, with switching output**

The mechanical frost protection thermostat / frost monitor **THERMASREG® FST** with switching output, fully-active sensor rod, with automatic reset, or with mechanical locking and manual reset, is available with capillaries in lengths of 0.6 m, 1.8 m, 3 m, 6 m, or 12 m. This frost protection monitor is used for air- and water-side temperature monitoring at heat exchangers, water circulation systems, and heating registers to prevent freezing up and to avoid frost damages, e. g. in ventilation and air conditioning ducts. All devices are self-secure with sensor breakage detection. In case of damage to the capillary tube – membrane system, the relay automatically switches to heating function. **FST-3** can also be used for monitoring liquids. The sensor tube can be installed inside an immersion sleeve. Mounting clamps **MK-05-K** are included in the delivery.

**FST - 1D / 5D / 7D / 8D**



**TECHNICAL DATA**

Switching capacity:	10 (2) A, AC 250 V; because of gold-plated switching contacts also switching of signal voltages < 24 V
Setting range:	-10...+15 °C / +14 °F...+59 °F, factory setting to w = +5 °C (+41 °F)
Operating difference:	2 ± 1 K (3.6 ± 1.8 °F)
Reproducibility:	± 0.5 K (± 0.9 °F)
Contact:	dust-proof micro switch as single-pole potential-free changeover contact
Sensor responding length:	approx. 40 cm
Length of capillary tube:	see table of types (0.6...12 m)
Resetting:	<b>FST-xD</b> automatic <b>FST-xD-HR</b> manual
Permissible medium:	<b>FST-1D/5D/7D/8D</b> air <b>FST-3D</b> water
Ambient temperatures:	maximum operating temperature: +70 °C (+158 °F) minimum operating temperature: w + min. +2 °C (min. +3.6 °F) storage / transport: -30...+70 °C (-22...+158 °F) capillary: max. +150 °C (+302 °F)
Process connection:	by mounting clamps <b>MK-05-K</b> (included in the scope of delivery)
Housing:	plastic, UV-resistant, material polyamide, 30 % glass-globe reinforced, with quick-locking screws (slotted / Phillips head combination), colour traffic white (similar to RAL 9016)
Housing dimensions:	126 x 90 x 50 mm (Tyr2)
Cable gland:	M16 x 1.5; including strain relief
Other materials:	mechanical sheet metal parts: galvanised steel capillary tube: copper capillary tube filling: R 507 switching contacts: Ag / Ni (90% / 10%) gold-plated (3 µm)
Installation length:	arbitrary
Routing:	bending radius > 35mm admissible vibration load ≤ ½g admissible tensile load < 100N
Electrical connection:	0.14 - 2.5 mm²
Protection class:	I (according to EN 60 730-1)
Protection type:	<b>IP 65</b> (according to EN 60 529)
Standards:	CE conformity, EMC directive 2014 / 30 / EU, low-voltage directive 2014 / 35 / EU
<b>FUNCTION</b>	Contact C-2: danger of frost / sensor breakage Contact C-3: normal operation
For further information and accessories see next page...	

**FST-3D**



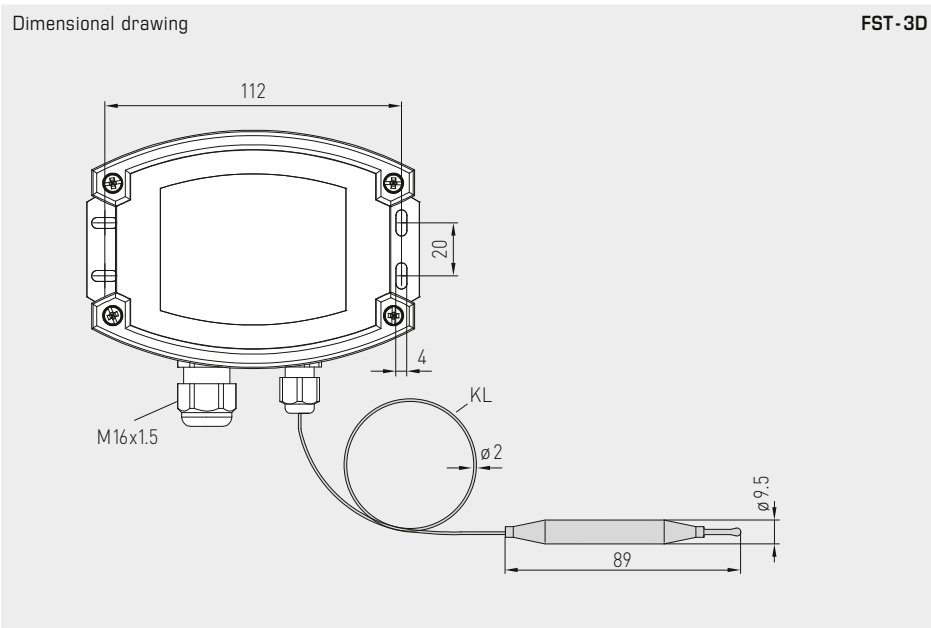
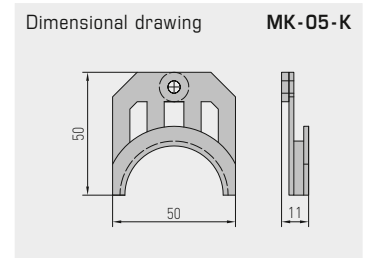
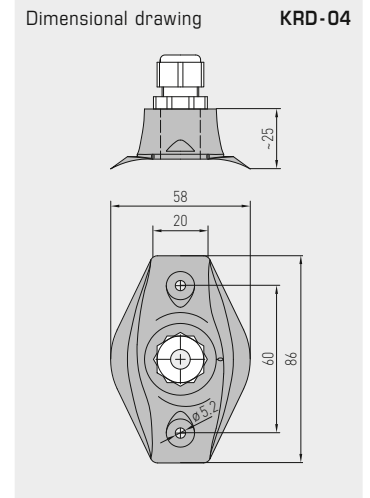
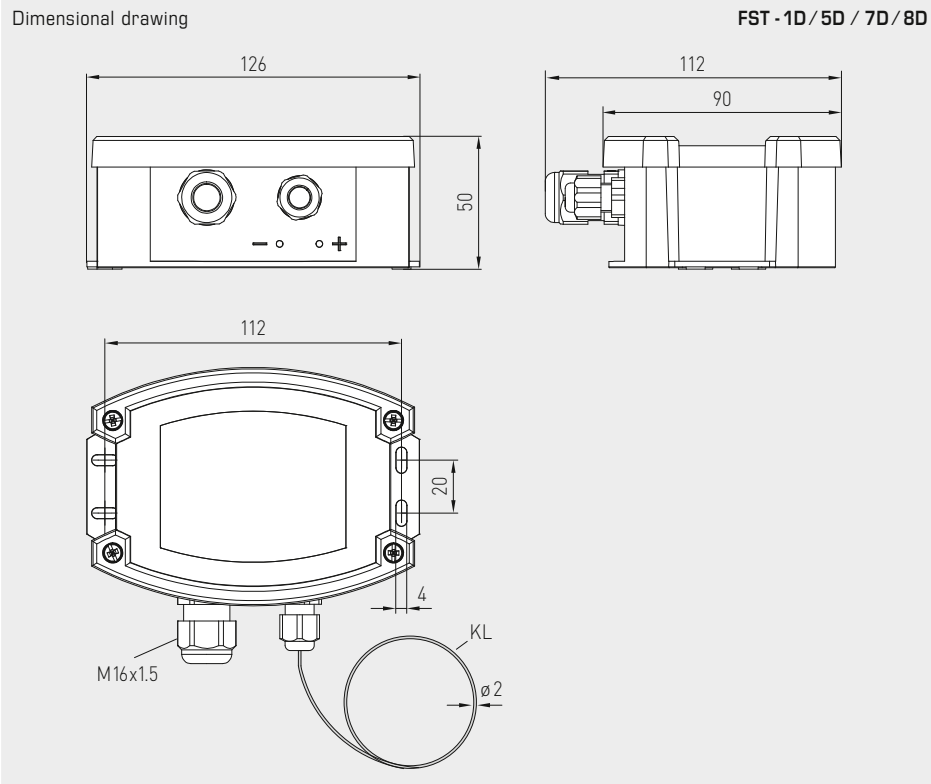



**Frost protection thermostats, mechanical, one-step, with switching output**

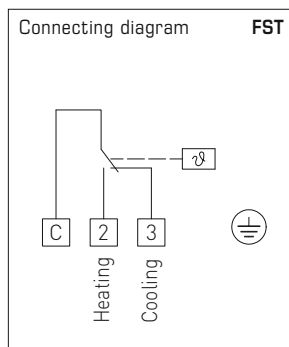
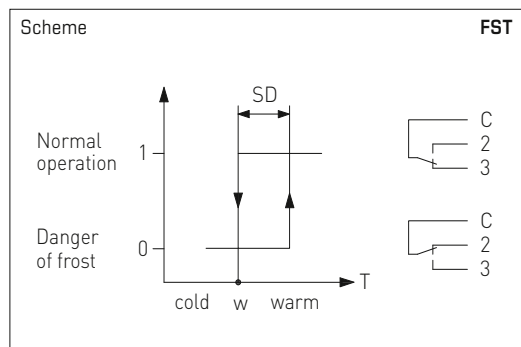

**FST - 1D / 5D / 7D / 8D - HR**  
(manual rest)



**FUNCTION**

The switch inside frost protection thermostat **FST** responds (closes contact C-2) when temperature falls below the preset temperature setpoint over a capillary tube length of at least 40cm. Simultaneously contact C-3 breaks and can be used as a signal contact. Resetting (closing contact C-3) happens automatically when temperature rises above the preset setpoint value again (on type **FST-xR** resetting must be done manually by pressing the reset button).

The **FST** is "intrinsically safe", i.e., in the event of damage to the capillary tube-membrane system, it automatically switches to the heating function. Contact C-2 closes and therefore can be used as operating contact. The air temperature is detected over the entire sensor length (capillary tube). The gas-filled (R507) membrane system and the capillary tube constitute one measuring unit, which is mechanically coupled to the microswitch.

**Capillary tube:** The capillary tube is laid uniformly at the hot side of the air heater to be protected (in case of air coolers in front of the air cooler) at a distance of approx. 5cm cross-wise to the heat exchanger tubes over the entire area. For test purposes, it is recommended to make a loop of approx. 20cm directly underneath the housing and before entering the air duct. To avoid damaging the capillary tube, a minimum bending radius of 20mm must be observed. Installation is facilitated by using the mounting clamps available under accessories.

**Frost simulation:** The frost situation can be simulated and functioning of the device can be tested by dipping the capillary tube testing loop into a pot filled with ice water.

**FST-3D-HR**  
(manual rest)



**WS-03**

Weather and sun protection hood (optional)





**FST-xD**  
TW = temperature monitor  
(automatically switching)



**FST-xD-HR**  
TB = temperature limiter  
(manual reset)



### THERMASREG® FST Frost protection thermostats, mechanical

Type / WG03B	Temperature Range	Thermal Operating Difference (fixed) approx.	Length of Capillary	Permissible Medium	Item No.	Price
<b>FST-xx D</b>						<b>TW</b>
FST-1D *	-10...+15 °C	2K (± 1 K)	6.0 m	air	1102-1021-0102-000	<b>83,00 €</b>
FST-3D *	-10...+15 °C	2K (± 1 K)	1.8 m	air / water	1102-1023-0102-000	<b>84,69 €</b>
FST-5D *	-10...+15 °C	2K (± 1 K)	3.0 m	air	1102-1022-0102-000	<b>80,74 €</b>
FST-7D *	-10...+15 °C	2K (± 1 K)	12.0 m	air	1102-1025-0102-000	<b>143,07 €</b>
FST-8D	-10...+15 °C	2K (± 1 K)	0.6 m	air	1102-1024-0102-000	<b>78,57 €</b>
<b>FST-xx D-HR</b>						<b>TB</b>
FST-1D-HR *	-10...+15 °C	2K (± 1 K)	6.0 m	air	1102-1021-1102-000	<b>99,71 €</b>
FST-3D-HR *	-10...+15 °C	2K (± 1 K)	1.8 m	air / water	1102-1023-1102-000	<b>102,19 €</b>
FST-5D-HR *	-10...+15 °C	2K (± 1 K)	3.0 m	air	1102-1022-1102-000	<b>99,36 €</b>
FST-7D-HR *	-10...+15 °C	2K (± 1 K)	12.0 m	air	1102-1025-1102-000	<b>157,62 €</b>
FST-8D-HR	-10...+15 °C	2K (± 1 K)	0.6 m	air	1102-1024-1102-000	<b>93,11 €</b>
Features:	FST-xD FST-xD-HR	TW = temperature monitor (automatically switching) TB = temperature limiter (manual reset)				

### ACCESSORIES

<b>KRD-04</b>	Capillary tube gland bracket	7100-0030-7000-000	<b>8,49 €</b>
<b>MK-05-K</b>	Mounting clamps (6 pieces) plastic (*= included in the scope of delivery)	7100-0034-1000-000	<b>9,41 €</b>
<b>TH-MS-01</b>	Immersion sleeves, brass, for FST-3	7100-0011-5402-000	<b>14,81 €</b>
<b>TH-VA-02</b>	Immersion sleeves, stainless steel V2A (1.4301), for FST-3	7100-0012-5402-000	<b>38,80 €</b>
<b>WS-03</b>	Weather and sun protection hood, 200 x 180 x 150 mm, stainless steel V2A (1.4301)	7100-0040-6000-000	<b>42,61 €</b>

For further information see last chapter!

**Duct frost protection thermostat,  
incl. mounting flange, mechanical, one-step,  
with switching output**

Mechanical frost protection thermostat / frost monitor **THERMASREG® FST-K** with switching output, duct tube monitored across the entire length, with automatic reset or with mechanical locking, with/without optional manual reset.

The frost protector is suitable for air side temperature monitoring at heat exchangers and heating registers to prevent freezing up and to avoid frost damage, e.g. in ventilation and air conditioning ducts. The FST-K is intrinsically safe and is equipped with sensor breakage detection. In the event of damage to the capillary membrane system, the frost sensor automatically switches to the heating function. The scope of delivery includes the mounting flange **MF-14-K**.

#### TECHNICAL DATA

Switching capacity:	10 (2) A, AC 250 V; because of gold-plated switching contacts also switching of signal voltages < 24 V
Setting range:	-10...+15 °C / +14 °F...+59 °F, factory setting to $w = +5 °C (+41 °F)$
Operating difference:	$2 \pm 1 K (3.6 \pm 1.8 °F)$
Reproducibility:	$\pm 0.5 K (\pm 0.9 °F)$
Contact:	dust-proof micro switch as single-pole potential-free changeover contact
Resetting:	<b>FST-K</b> automatic <b>FST-K-HR</b> manual (by hand)
Permissible medium:	Air
Ambient temperatures:	maximum operating temperature: +70 °C (+158 °F) minimum operating temperature: $w + \text{min. } +2 °C (\text{min. } +3.6 °F)$ storage / transport: -30...+70 °C (-22...+158 °F)
Housing:	plastic, UV-resistant, material polyamide, 30% glass-globe reinforced, colour traffic white (similar to RAL 9016)
Housing dimensions:	108 x 70 x 73.5 mm (Thor 2)
Cable gland:	M20 x 1.5; with strain relief
Process connection:	by mounting flange, plastic (included in the scope of delivery)
Electrical connection:	0.14 - 2.5 mm <sup>2</sup> , via screw terminals
Protective tube:	<b>metal</b> , material CuZn37 (2.0321), Ø 14 mm, NL = 205 mm
Other materials:	mechanical sheet metal parts: galvanised steel capillary tube: copper capillary tube filling: R 507 switching contacts: Ag / Ni (90% / 10%) gold-plated (3 µm)
Protection class:	I (according to EN 60730-1)
Protection type:	<b>IP 65</b> (according to EN 60529)
Standards:	CE conformity, EMC Directive 2014 / 30 / EU, Low Voltage Directive 2014 / 35 / EU
<b>FUNCTION</b>	Contact C-2: danger of frost / sensor breakage Contact C-3: normal operation
For further information and accessories see next page...	



Duct frost protection thermostat, incl. mounting flange, mechanical, one-step, with switching output



Dimensional drawing

FST-K

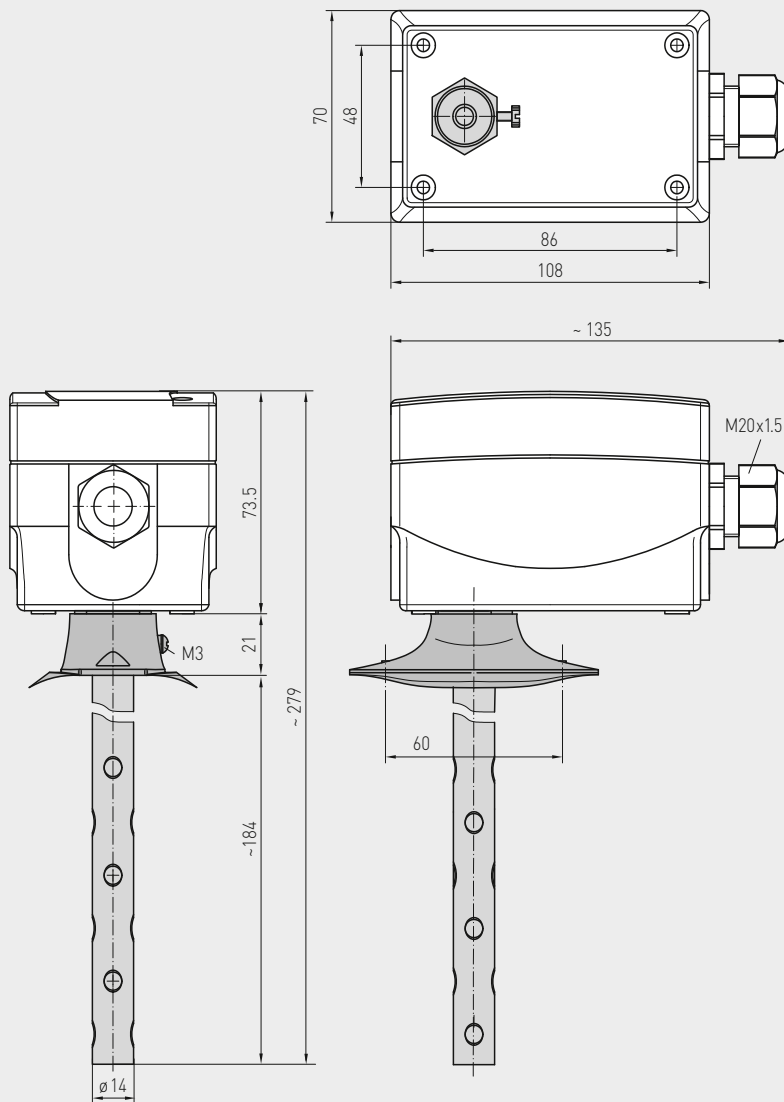

FST-K



FST-K-HR with manual reset



Dimensional drawing

MF-14-K

MF-14-K  
Mounting flange,  
plastic

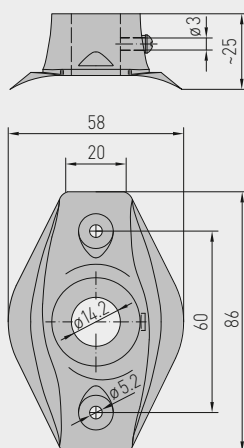

Duct frost protection thermostat,  
incl. mounting flange, mechanical, one-step,  
with switching output

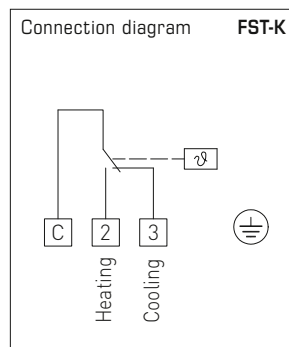
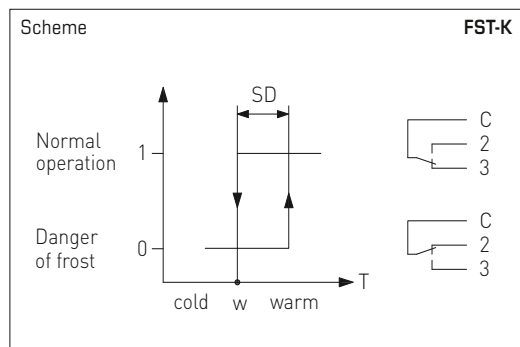

**FUNCTION**

The switch in the **FST-K** duct frost protection thermostat responds if the temperature across the entire length of the duct tube falls below the preset temperature setpoint (closes contact C-2). Contact C-3 opens at the same time and can be used as a signal contact. Resetting occurs automatically (contact closes C-3) if the temperature rises above the preset setpoint again (on type **FST-K-HR**, resetting must be performed manually using the reset button).

The **FST-K** is "intrinsically safe", i.e., in the event of damage to the capillary tube-membrane system, it automatically switches to the heating function. Contact C-2 closes and can therefore be used as an operating contact. The air temperature is detected over the entire length of the sensor (capillary tube). The gas-filled (R507) membrane system and the capillary tube constitute one measuring unit, which is mechanically coupled to the microswitch.





S+S REGELTECHNIK

THERMASREG® FST-K

Duct frost protection thermostat,  
incl. mounting flange, mechanical, one-step,  
with switching output

FST-K

TW = temperature monitor  
(automatically switching)

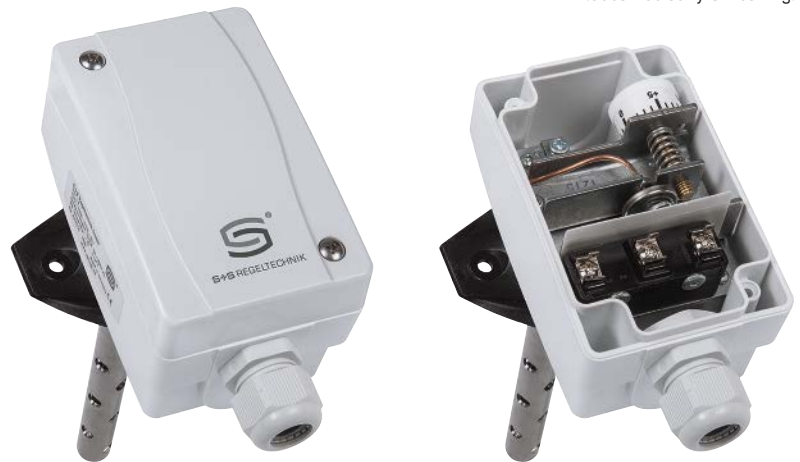

FST-K-HR

TB = temperature limiter  
(manual reset)



THERMASREG® FST-K Duct frost protection thermostat, mechanical

Type / WG02	Temperature Range	Thermal Operating Difference (fixed) approx.	Function	Permissible Medium	Item No.	Price
<b>FST-K</b>					<b>TW</b>	
FST-K	-10...+15°C	2K (± 1K)	TW	air	1102-1064-0100-001	<b>114,39 €</b>
<b>FST-K-HR</b>					<b>TB</b>	
FST-K HR	-10...+15°C	2K (± 1K)	TB	air	1102-1064-1100-000	<b>128,95 €</b>
Equipment:	FST-K FST-K-HR	<b>TW = temperature monitor (automatically switching)</b> <b>TB = temperature limiter (manual reset)</b>				

ACCESSORIES

<b>MF-14-K</b>	<b>Mounting flange, plastic</b>	7100-0030-2000-000	<b>9,10 €</b>
----------------	---------------------------------	--------------------	---------------

For further information see last chapter!

**2-phase frost protection thermostat,  
with control and cascading input,  
with active and switching output**

FS-20

Electronic frost protection thermostat / frost monitor **THERMASREG® FS-20** with switching relay output, continuous temperature and valve output (summation output 0–10V) and control and cascading output (0–10V), optionally with connection for heating element, in an impact-resistant plastic housing with quick-locking screws, with display by default, with fully active sensorrod made from copper.

The frost monitor is used to monitor air conditioning systems, heat exchangers, heating registers and similar systems, and protects against frost damage and freezing. Falling below the limit value is detected at the coldest measuring point of the capillary tube, the sensor rod is active along its entire length. Uses internal diagnostics to detect capillary breakage, power failure or electric damage to the sensor as an error and the relay automatically switches to frost.

The innovative 2-phase frost protection thermostat enables simple combination of several devices (cascading) for demand-oriented, comprehensive frost monitoring. The delivery scope includes the mounting clamps **MK-05-K** for expert attachment of the sensor rod.



**TECHNICAL DATA**

Power supply:	24 V AC / DC (± 10 %)
Load resistance:	$R_L > 50 \text{ k}\Omega$
Measuring range:	0...+15 °C
Input:	1 x 0-10V control input DDC 1 x 0-10V <b>ascading input</b>
Output:	1 x 0-10V output temperature (corresponding to 0...+15 °C) 1 x 0-10V output valve (frost signal with control voltage and cascading) 1 x potential-free changeover contact (24 V), range of adjustment 0...+15 °C
Current consumption:	max. 100 mA at 24 V DC ( <b>FS-20</b> without heating element) max. 200 mA at 24 V DC ( <b>FS-20 xx HE</b> with heating element)
Accuracy:	typically ± 1 K (at +10 °C)
Hysteresis of the switch step:	2K
Turn-on/run-in time:	< 1 min
Response time:	$t_{90} < 5 \text{ s}$
Sensor and capillary tube:	Copper sensor rod, length of 3 m or 6 m, active along the entire sensor length, min. response length of 25 cm
Ambient temperatures:	<b>Sensor and capillary tube:</b> -20...+60 °C (capillary tube at a distance of > 20 cm from the housing) <b>Housing:</b> -15...+50 °C <b>Storage/transport:</b> -30...+70 °C
Housing:	plastic, UV-resistant, material polyamide, 30 % glass-globe reinforced, with quick-locking screws (slotted / Phillips head combination), colour traffic white (similar to RAL 9016), housing cover for display is transparent!
Housing dimensions:	126 x 90 x 50 mm (Tyr 2)
Cable gland:	M 16 x 1.5; including strain relief, exchangeable, max. inner diameter 10.4 mm
Process connection:	by mounting clamps <b>MMK-05-K</b> (included in the scope of delivery)
Electrical connection:	0.14 - 1.5 mm <sup>2</sup> , via screw terminals
Routing:	bending radius > 35mm admissible vibration load ≤ ½g admissible tensile load < 100N
Permitted humidity:	< 95 % r. H., non-precipitating air
Protection class:	III (according to EN 60 730)
Protection type:	<b>IP 65</b> (according to EN 60 529)
Standards:	CE-conformity, electromagnetic compatibility according to EN 61 326, EMC directive 2014 / 30 / EU
Equipment:	<b>display with illumination</b> , three-line, cutout approx. 70 x 40 mm (W x H), for displaying the actual temperature, measuring range overrange/underrange of the set switch point (frost protection temperature), and alarm indicator for "frost" or "error" (capillary breakage, overvoltage/undervoltage)
Internal diagnostics:	<b>Error 1</b> in case of cable / capillary breakage <b>Error 2</b> in case of undervoltage / overvoltage (relay automatically switches to frost)



2-phase frost protection thermostat, with control and cascading input, with active and switching output

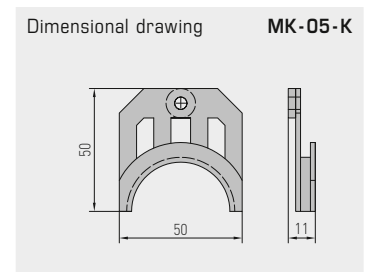
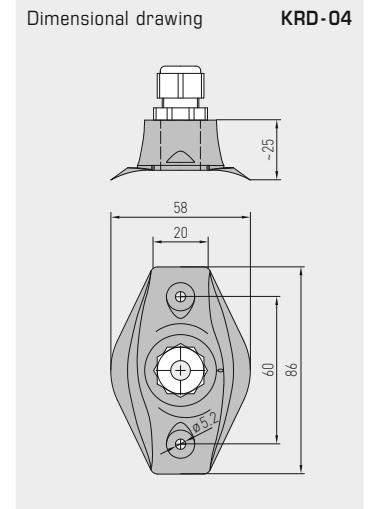
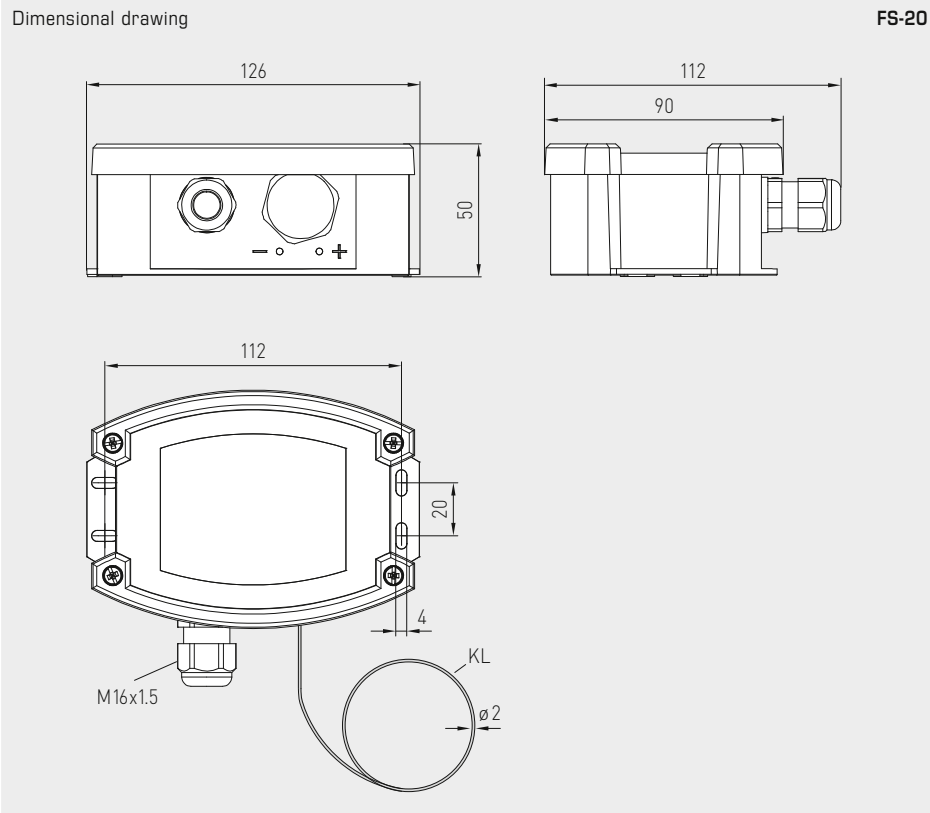

**WS-03**  
Weather and sun protection hood (optional)



**MK-05-K**



**KRD-04**



**2-phase frost protection thermostat,  
with control and cascading input,  
with active and switching output**

**FUNCTION**

The filling used in the copper capillary tube in the frost protection monitor generates a pressure signal that is proportional to the lowest temperature on the entire capillary tube (but min. 200mm). This is converted into an electrical signal by a sensor and electronically amplified. The standard signal 0-10V generated as a result corresponding to 0...+15°C is issued. This voltage is available at the "Temp." terminal.

The internal potentiometer can be used to specify a **frost switchpoint "FS"** for the potential-free changeover contact in the range from 0°C (left limit stop) to +15°C (right limit stop). If this switchpoint "FS" is undershot, the relay output switches to the "frost protection" position (contact "W" connected to contact "Ö"). If the temperature rises by more than 2K above the set switchpoint "FS", the device switches back to normal operating mode if **"Reset Auto"** is selected. The relay drops out to the initial position (contact "W" connected to contact "S"). If the **"Reset Hand"** operating mode is selected, the relay output does not automatically switch even if the set switchpoint "FS" +2K is exceeded, but must be manually reset from the **reset button**.

In addition, a second voltage output "AV", mapped by 0-10V, is available. At a voltage of 0V at the control input "SE", the output voltage "AV" is always 0V if the measured temperature is at least 6K above the set switchpoint "FS". If the measured temperature falls below the set switchpoint "FS"+6K, the voltage output "AV" increases in a linear fashion from 0V to 10V. The increase here amounts to 1.67 V for every degree Kelvin by which the temperature approaches the preset switchpoint "FS". The output voltage 10V is therefore issued at "FS" = measured temperature. If you increase "SE", the output voltage "AV" is increased by this amount. The "AV" output therefore represents a summation output for the input variables "SE" and "Frost signal". In this case, the "Frost signal" variable describes the output behaviour of "AV" at "SE" = 0V. The maximum output voltage is restricted to 10V.

Several frost protection devices can be connected to each other via the **cascading input "KE"** to cover a larger channel cross-section for frost monitoring. The AV output of the first device is connected to the KE input of the second device. The internal device logic decides on the priority frost signal of both devices for controlling the heating register valve.

In the event of capillary breakage, electrical sensor damage (cable breakage), voltage failure, falling short of the permissible voltage level or exceeding it, the relay output is automatically switched to "Frost protection" (contact "W" connected to contact "Ö").

**NOTE**

The capillary tube must be securely seated in the socket and must not twist.  
A redundant setup to protect critical systems is **absolutely necessary**.

Display readout
FS-20

**Normal operation**  
Actual temperature and set switchpoint temperature

**Frost protection alarm**  
Actual temperature is below switchpoint temperature

**Measuring range exceeded**  
Actual temperature rises above +15°C

**Measuring range underranged**  
Actual temperature falls below 0°C

**1 ERROR** Error message 1 in case of cable/capillary breakage

**2 ERROR** Error message 2 in case of undervoltage/overvoltage

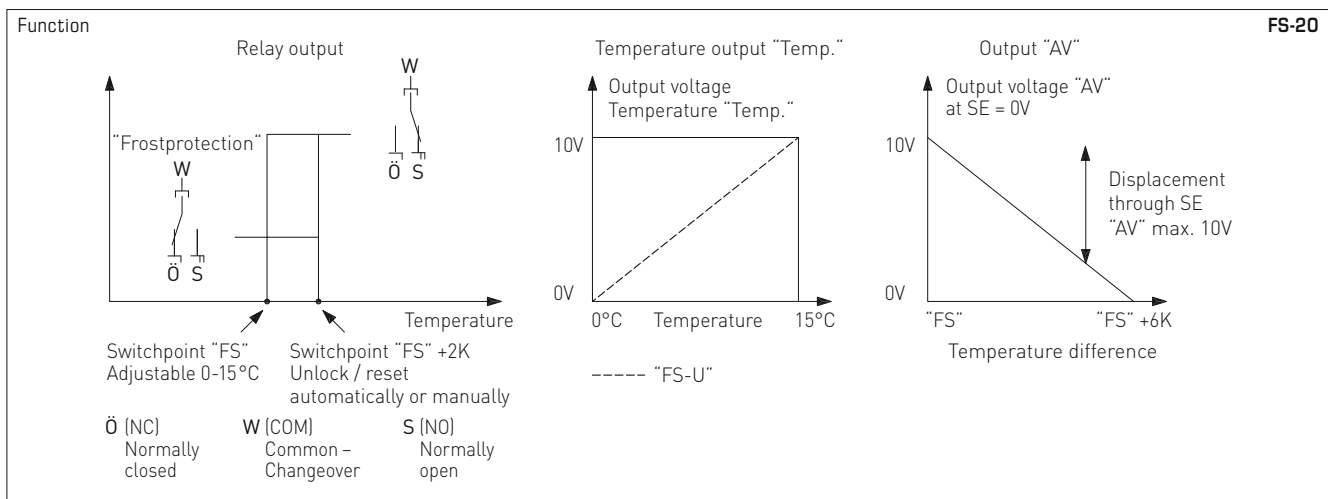
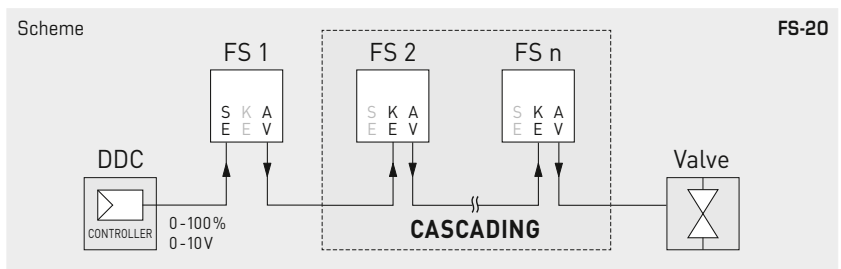

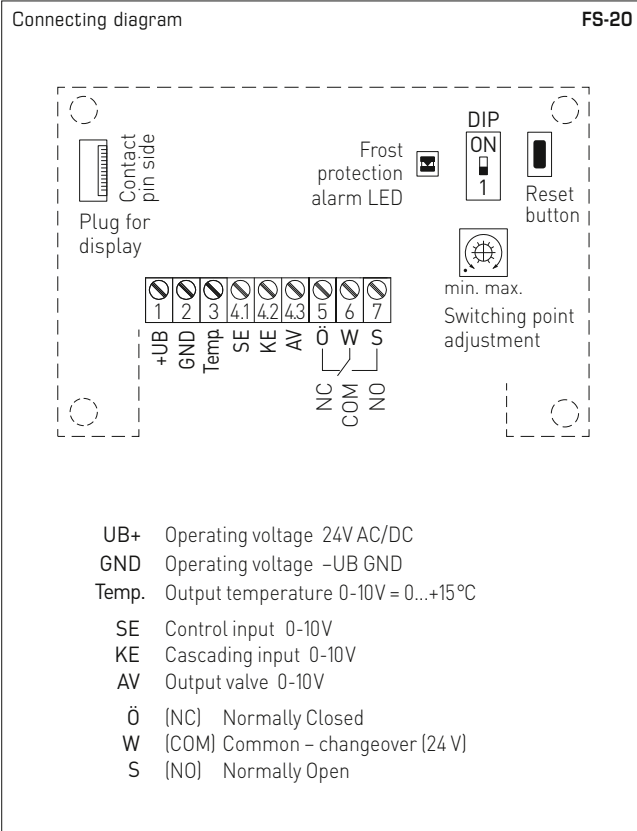

DIP switch <span style="float: right;">FS-20</span>	
Resetting after frost protection (Mode adjustable)	DIP 1
Reset Hand (manually) Alarm remains saved	ON
Reset Auto (automatically) Alarm is reset automatically (default)	OFF

**THERMASREG® FS-20** Two-phase frost protection thermostats

Type/WG02	Measuring Range	Output	Sensor length	Display	Item No.	Price
<b>FS-20</b>						
FS20-UW 3m LCD	0...+15°C	2 x 0-10V, 1 x changeover contact	3,0m	■	1102-1012-2102-030	<b>243,83 €</b>
FS20-UW 6m LCD	0...+15°C	2 x 0-10V, 1 x changeover contact	6,0m	■	1102-1011-2102-030	<b>286,44 €</b>
<b>FS-20 xx HE with heating element</b>						
FS20-UW-HE 3m LCD	0...+15°C	2 x 0-10V, 1 x changeover contact	3,0m	■	1102-1012-2112-030	<b>265,36 €</b>
FS20-UW-HE 6m LCD	0...+15°C	2 x 0-10V, 1 x changeover contact	6,0m	■	1102-1011-2112-030	<b>309,02 €</b>

ACCESSORIES			
<b>KRD-04</b>	Capillary tube gland bracket		7100-0030-7000-000 <b>8,49 €</b>
<b>MK-05-K</b>	Mounting clamps (6 pieces) plastic (included in the scope of delivery)		7100-0034-1000-000 <b>9,41 €</b>
<b>WS-03</b>	Weather and sun protection hood, 200x180x150 mm, stainless steel V2A (1.4301)		7100-0040-6000-000 <b>42,61 €</b>

For further information see last chapter!



## Temperature controller for top hat rail installation for remote sensor, with multi-range switching and switching output

Electronic top hat rail thermostat / top hat rail temperature controller **THERMASREG® TET** for installation in distributor boxes or control cabinets, with switching output, multi-range switching, and adjustable hysteresis. It is used for electronic control and monitoring of temperatures by remote sensors in the residential sector (e.g. in connection with floor heating systems), in halls and greenhouses and in the industrial sector.

This controller is provided with sensor breakage detection and a switch-off function.

### TECHNICAL DATA

Power supply:	24 V DC, +10% / -15%; 24 V AC or 230 V AC, +10% / -15%, 50 - 60 Hz
Power consumption:	2.5 VA
Control range:	-10...+30 °C; +20...+80 °C; +60...+120 °C, selectable
Input:	Pt1000
Output:	relay as single-pole, potential-free changeover contact (1x)
Switching capacity: (Contact load)	max. 6 A 250 V AC U <sub>e</sub> / I <sub>e</sub> AC-15, 120 V / 3.5 A, 240 V / 3 A U <sub>e</sub> / I <sub>e</sub> DC-13, 24 V / 2.5 A EN 60947-5-1, VDE 0435
Operating Difference:	adjustable
Lifetime:	changeover contact mechanical: 5 x 10 <sup>6</sup> changeover contact electrical: 1 x 10 <sup>5</sup>
Ambient conditions:	-20...+60 °C, non-precipitating air
Operating mode indicator:	LED
Housing:	plastic, colour black-grey (similar to RAL 7021) and light grey (similar to RAL 7035), width: 45 mm, 3TE
Electrical connection:	0.14 - 2.5 mm <sup>2</sup> via terminal screws
Mounting:	on DIN top hat rail
Humidity:	< 90 % r. H., non-precipitating air
Protection class:	II (according to EN 60730)
Protection type:	IP 20 at front side (according to EN 60529)
Standards:	CE conformity, electromagnetic compatibility according to EN 61326, EMC directive 2014 / 30 / EU, low-voltage directive 2014 / 35 / EU

### FUNCTION

The range of interpretation is selected at the lower potentiometer.

Three measuring ranges can be chosen: -10...+30 °C; +20...+80 °C; +60...+120 °C.

The temperature to be monitored is determined by the potentiometer »Setpoint« and the switchpoints (hysteresis) are defined at the potentiometer »Hyst.«

When temperature at the Pt1000 exceeds the value of »Setpoint + Hyst.«, the output relay switches to rest position (switched off).

When temperature falls below »Setpoint - Hyst.«, the output relay is reactivated.

The following conditions result in a drop of the relay to rest position:

Excess temperature, short circuit, or wire breakage at the Pt 1000 sensor, failure of power supply.

Measuring input and power supply have no electric connection i.e. are galvanically isolated.

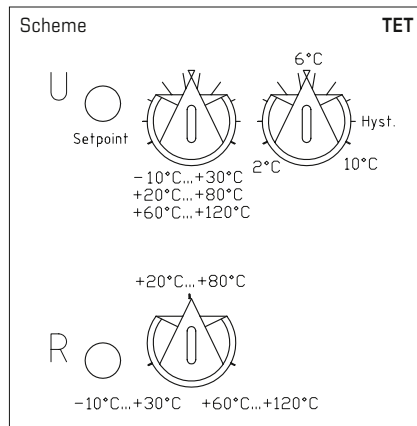
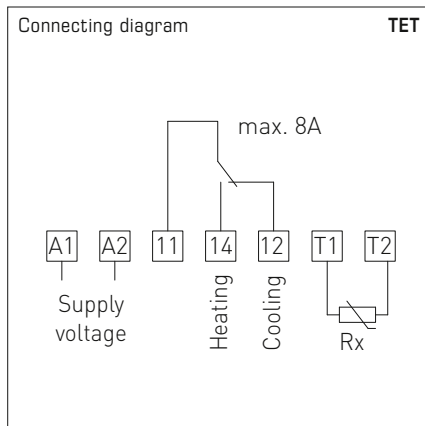
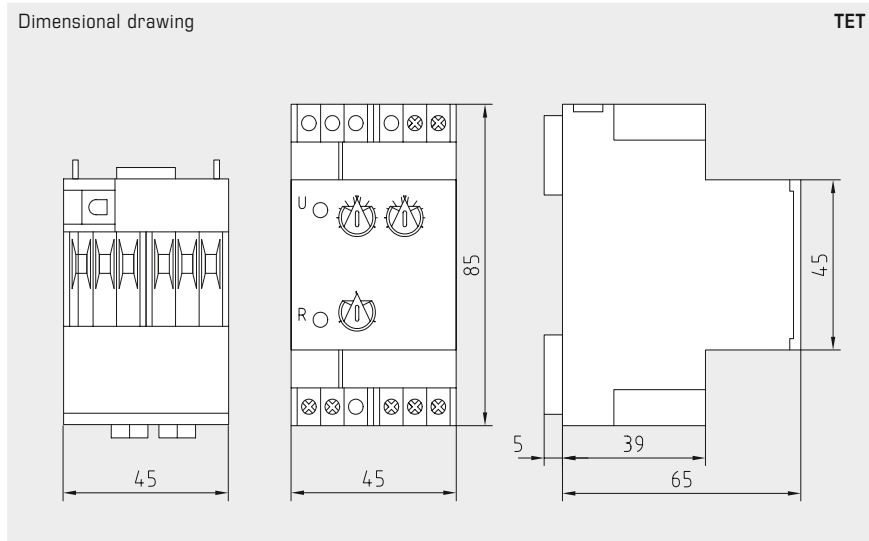

THERMASREG® TET Temperature controller for top hat rail installation					
Type / WG01	Supply Voltage	Input Sensor	Output	Item No.	Price
<b>TET</b>					
TET-230VAC	230 V AC, 2,5 VA	Pt1000	1 x changeover contact (potential-free)	1 102-6021-0000-000	<b>192,22 €</b>
TET-24VAC	24 V AC, 2,5 VA	Pt1000	1 x changeover contact (potential-free)	1 102-6022-0000-000	<b>192,22 €</b>
TET-24VDC	24 V DC, 2,5 VA	Pt1000	1 x changeover contact (potential-free)	1 102-6023-0000-000	<b>192,22 €</b>



## Humidity

**HYGRASGARD®** humidity sensors and **HYGRASREG®** humidity controllers will never let you down when mold and rust formation must be prevented. With an accuracy of 2% RH, they will always keep you on the safe side. Their application range spans from standard uses in facility automation to highly demanding cleanroom installations.

### APPLICATION RANGE

- > Refrigeration, air conditioning, ventilation and cleanroom technology
- > Food and pharmaceutical industry
- > Hospitals, museums, office buildings and greenhouses
- > Production facilities, laboratories, computer rooms and control cabinets
- > Meteorology



## HYGRASGARD® & HYGRASREG®

360 – 457

Room sensors		
RFF/RFTF	Room humidity sensor, on-wall	367
FSFM/FSFTM	Room humidity sensor, in-wall	369
DFF/DFTF	In-ceiling humidity sensor	373
RPFF-SD	Pendulum room humidity sensor	415
RPFF/RPFTF	Pendulum room humidity sensor	419
RPFF/RPFTF-25	Pendulum room humidity sensor, pluggable	423
VFF/VFTF	Showcase humidity sensor	427
Duct sensors		
KFF/KFTF-SD	Duct humidity sensor	400
KFF/KFTF	Duct humidity sensor	401
KFF/KFTF-20	Duct humidity sensor	403
KFTF-20-VA	Duct humidity sensor (Stainless steel housing Tyr2E)	409
KAVTF	Duct humidity sensor	413
On-wall sensors		
AFF/AFTF-SD	On-wall humidity sensor	377
AFF/AFTF	On-wall humidity sensor	382
AFF/AFTF-20	On-wall humidity sensor	385
AFTF-20-VA	On-wall humidity sensor (Stainless steel housing Tyr2E)	391
AFF/AFTF-25	On-wall humidity sensor, pluggable	383
AAVTF	Outdoor humidity sensor	395

Hygrostats		
RH-2	Room hygrostat, one-step	429
AH-40	On-wall hygrostat, one-step	435
KH-10	Duct hygrostat, one-step	441
KH-40	Duct hygrostat, one-step	443

Hygrothermostats		
RHT	Room hygrothermostat, one-step	428
RHT-30	Room hygrothermostat, two-step	433
AHT-30	On-wall hygrothermostat, two-step	439
KHT-30	Duct hygrothermostat, two-step	447

Condensation control switch, dew point control switch, leakage sensor		
KW-SD	Condensation control switch	450
KW	Condensation control switch	451
TW	Dew point control switch	455
LS	Leakage sensor	457

Immersion sleeves and accessories		
see chapter Accessories		636





# Humidity



## HYGRASGARD® & HYGRASREG®

### Multifunctional sensor technology for humidity and temperature

#### Broad Spectrum

All our humidity measuring transducers are designed to be multifunctional. This reduces the diversity of types while expanding their possible applications. Thanks to microprocessor technology, almost any measuring range can be represented, including custom specifications. Multi-range switching is selectable via DIP switches.

#### Optimum Precision

These devices are developed and manufactured according to the latest criteria; latest generation digital sensors are installed. All devices are produced at our factory and are calibrated and 100% checked in our climatic exposure test cabinets. Each sensor is precisely re-adjustable using offset potentiometers. Take advantage of our experience, our development, manufacturing and product know-how and order these products directly from the manufacturer.

#### Approved Safety

The **HYGRASGARD® 3112** with current output (Test No. D8 0910 69871 003) and the **HYGRASGARD® 3111** with voltage output (Test No. D8 0910 69871004) are tested and certified according to DIN EN 61326-1:2006 and EN 61326-2-3:2006 by TÜV SÜD.



DIN tested/certified devices



RoHS conforming materials



ESD compliant manufacturing



CE compliance tested by external laboratories

#### Certified Quality



Our development and production in Nuremberg/Germany is certified by TÜV Thüringen according to DIN EN ISO 9001:2015.



GOST certificates



EAC certified



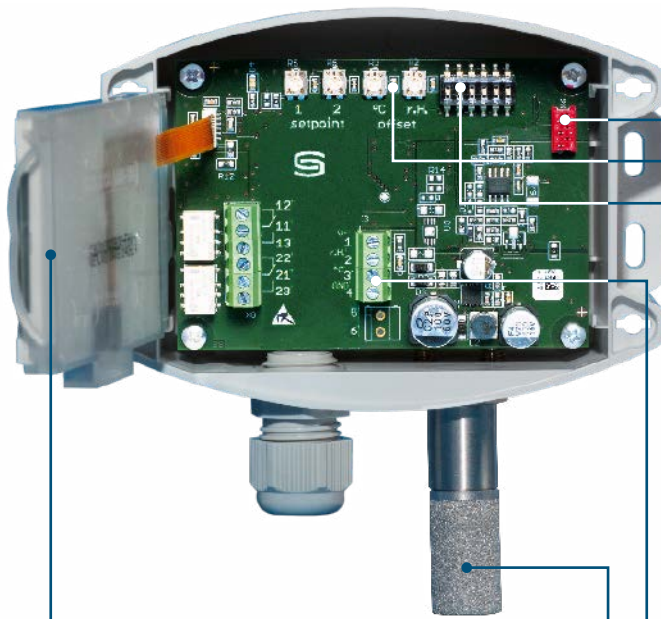

1



### Extra-Large Display (70 x 40 mm)

With backlighting as well as display of range violation, sensor breakage, sensor short circuit and physical units

2



### Quality Assurance

Calibration and balancing are done by means of the bus system in climate cabinets

3

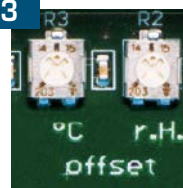

### Offset Potentiometer

For fine adjustment (zero point offset) and readjustment upon recalibration

4

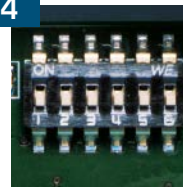

### DIP Switches

For multi-range toggling as well as setting of measuring ranges, response times, damping times, units and configuration levels

5

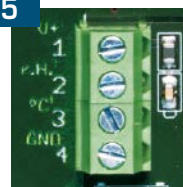

### Screw Terminals

Active output signals 0-10V, 4...20mA or switched output

6



### Digital Humidity & Temperature Probe

Highly precise, longterm stable and temperature compensated

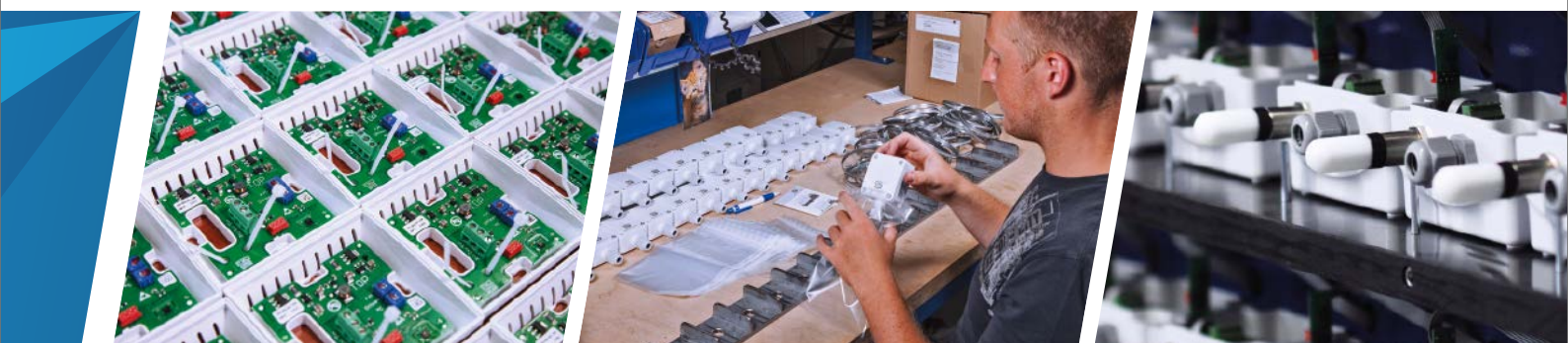

**Room humidity and temperature sensors ( $\pm 2.0\%$ ),  
on-wall, calibratable,  
with active/passive output**

The calibratable room humidity and temperature sensor **HYGRASGARD® RFF/RFTF** measures the relative humidity and/or temperature of air. It converts the measurands humidity and temperature into standard signals of 0-10V or 4...20mA and is available with or without an optional display (for displaying actual humidity and actual temperature) in an elegant housing made of plastic, with snap-on lid, base with 4-hole attachment for installation on vertically or horizontally installed in-wall flush boxes, with predetermined breaking point for on-wall cable entry. The relative humidity (in % r.H.) is the quotient of water vapour partial pressure divided by the saturation vapour pressure at the respective gas temperature.

It is used in non-aggressive dust-free atmospheres in refrigeration, air conditioning, ventilation and clean room technology, in interior rooms such as residential rooms, offices, hotels, technical rooms, meeting rooms and convention centres. These measuring transducers are designed for exact detection of air temperature and humidity. A digital long-term stable sensor is used as a measuring element for humidity and temperature measurement. Fine adjustment by the user is possible.

### TECHNICAL DATA

Power supply:	24 V AC ( $\pm 20\%$ ) and 15...36V DC for U variant 15...36V DC for I variant, depending on working resistance, residual ripple stabilised $\pm 0.3V$
Working resistance:	$R_a \text{ (ohm)} = (U_b - 14V) / 0.02A$ for I variant
Load resistance:	$R_L > 5k\Omega$ for U variant
Power consumption:	< 1.1 VA / 24 V DC ; < 2.2 VA / 24 V AC
Sensors:	<b>digital humidity sensor with integrated temperature sensor,</b> small hysteresis, high long-term stability

### HUMIDITY

Measuring range, humidity:	0...100% r. H. (output corresponding to 0 -10 V or 4...20 mA)
Operating range, humidity:	0 ... 95% r. H. (non-precipitating air)
Deviation, humidity:	typically $\pm 2.0\%$ (20...80% r. H.) at +25 °C, otherwise $\pm 3.0\%$
Output, humidity:	0-10 V for U variant 4...20mA for I variant, working resistance < 800 $\Omega$ , see load resistance diagram

### TEMPERATURE

Measuring range, temperature:	0...+50 °C (output corresponding to 0 -10V or 4... 20mA or Ohm value) others upon request!
Operating range, temperature:	0...+50 °C
Deviation, temperature:	typically $\pm 0.2K$ at +25 °C
Output, temperature:	0 -10V or 4 ... 20 mA or Ohm value
Ambient temperature:	storage -25...+50 °C, operation -5...+55 °C
Electrical connection:	2-, 3- or 4-wire connection (see connecting diagram) 0.14 -1.5 mm <sup>2</sup> via terminal screws
Housing:	plastic, material ABS, colour pure white (similar to RAL 9010)
Housing dimensions:	85 x 85 x 27 mm (BalduR 1)
Installation:	wall mounting or on in-wall flush box, $\varnothing 55$ mm, base with 4-hole for mounting on vertically or horizontally installed in-wall flush boxes for cable entry from the back, with predetermined breaking point for on-wall cable entry from top/bottom in case of plain on-wall installation
Long-term stability:	$\pm 1\%$ per year
Protection class:	III (according to EN 60 730)
Protection type:	<b>IP30</b> (according to EN 60 529)
Standards:	CE conformity, according to EMC directive 2014 / 30 / EU, according to EN 61326-1, according to EN 61326-2-3
Optional:	two-line display with illumination, 36x15 mm (W x H), for displaying ACTUAL temperature and/or ACTUAL humidity

The two-line display readout switches between the ACTUAL humidity reading in % r. H. and the ACTUAL temperature reading in °C.

Backlighting is installed for better instrument readability.

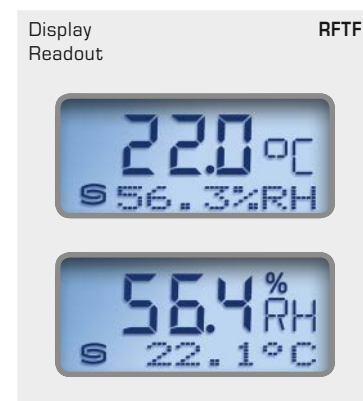



Dimensional drawing  
(Balduur 1)

RFF  
RFTF

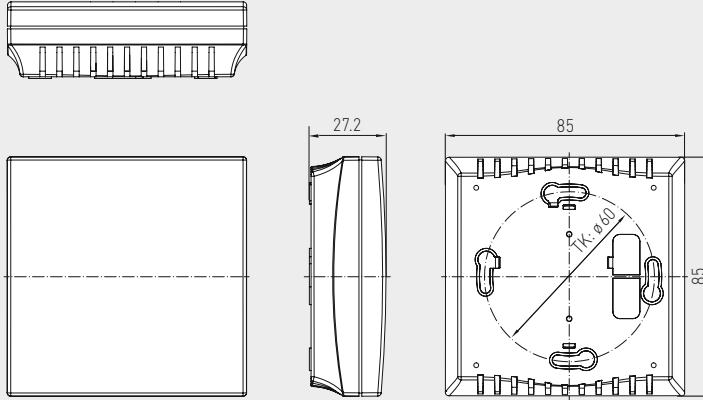

RFF  
RFTF



RFF  
RFTF  
without display

RFF  
RFTF  
with display



RFF  
RFTF  
with display



Room humidity and temperature sensors ( $\pm 2.0\%$ ),  
on-wall, calibratable,  
with active/passive output

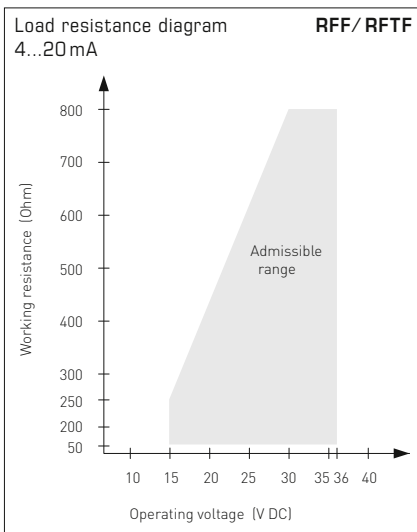
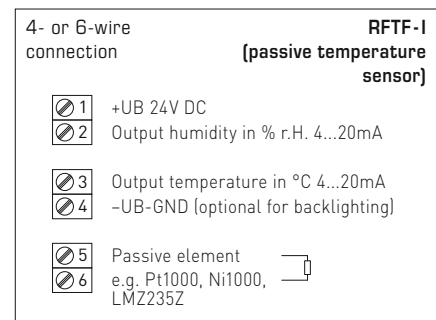
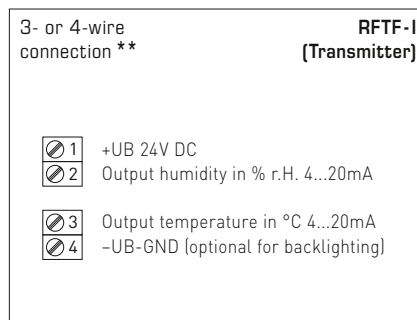
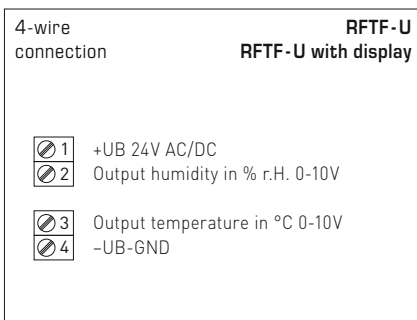
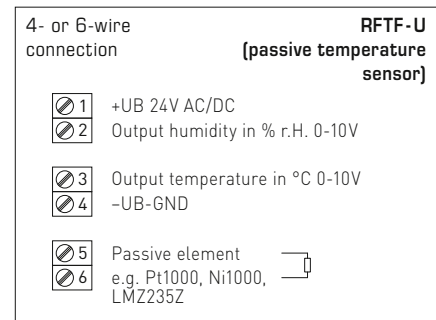
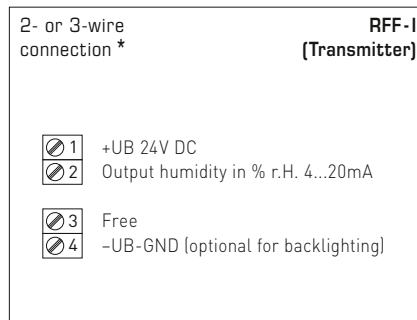
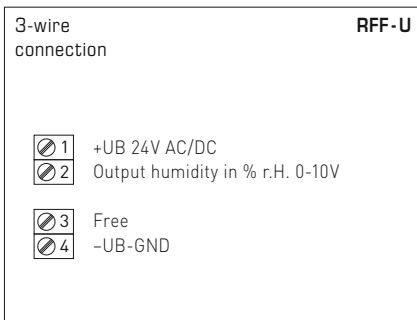
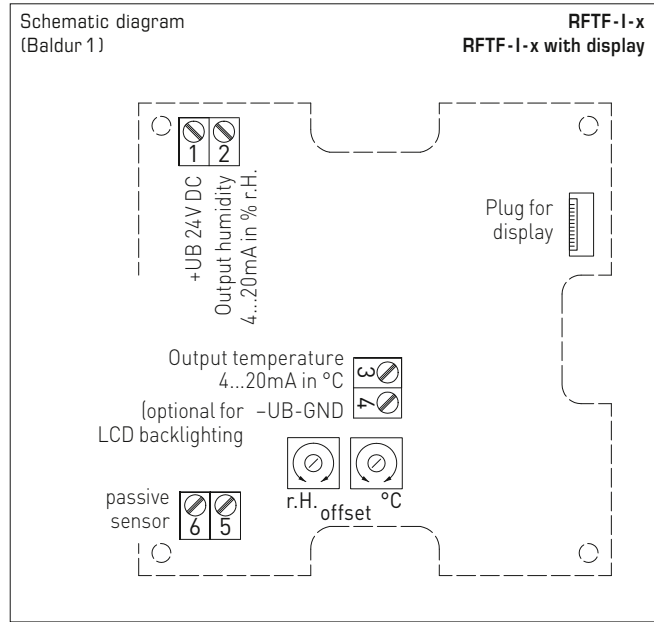
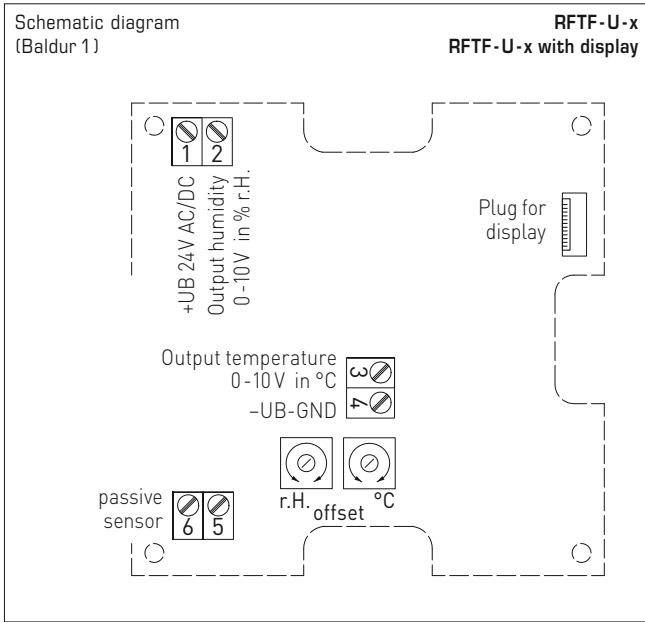

**Connection\*:**  
2-wire connection for devices with / without display (not illuminated)  
3-wire connection for devices with illuminated display

**Connection\*\*:**  
3-wire connection for devices with / without display (not illuminated)  
4-wire connection for devices with illuminated display

At the **I variant** the humidity path must be connected!



**Humidity table**

MR: 0...100% r.H.

% r.H.	U <sub>A</sub> in V	I <sub>A</sub> in mA
0	0	4.0
5	0.5	4.8
10	1.0	5.6
15	1.5	6.4
20	2.0	7.2
25	2.5	8.0
30	3.0	8.8
35	3.5	9.6
40	4.0	10.4
45	4.5	11.2
Continued at the right...		

% r.H.	U <sub>A</sub> in V	I <sub>A</sub> in mA
50	5.0	12.0
55	5.5	12.8
60	6.0	13.6
65	6.5	14.4
70	7.0	15.2
75	7.5	16.0
80	8.0	16.8
85	8.5	17.6
90	9.0	18.4
95	9.5	19.2
100	10.0	20.0

**Temperature table**

MR: 0...+50 °C

°C	U <sub>A</sub> in V	I <sub>A</sub> in mA
0	0.0	4.0
5	1.0	5.6
10	2.0	7.2
15	3.0	8.8
20	4.0	10.4
25	5.0	12.0
30	6.0	13.6
35	7.0	15.2
40	8.0	16.8
45	9.0	18.4
50	10.0	20.0

HYGRASGARD® RFF		Room humidity sensors					
HYGRASGARD® RFTF		Room humidity and temperature sensors					
Type/WG01	Measuring Range / Readout		Output		Display	Item No.	Price
	Humidity	Temperature	Humidity	Temperature		(Baldur 1)	
<b>RFF</b>							<b>(active)</b>
RFF-I	0...100% r.H.	–	4...20mA	–		1201-41A2-0000-000	113,25 €
RFF-I LCD	0...100% r.H.	–	4...20mA	–	■	1201-41A2-0200-000	166,10 €
RFF-U	0...100% r.H.	–	0-10V	–		1201-41A1-0000-000	113,25 €
RFF-U LCD	0...100% r.H.	–	0-10V	–	■	1201-41A1-0200-000	166,10 €
<b>RFTF</b>							<b>(active)</b>
RFTF-I	0...100% r.H.	0...+50 °C	4...20mA	4...20mA		1201-41A2-1000-000	116,77 €
RFTF-I LCD	0...100% r.H.	0...+50 °C	4...20mA	4...20mA	■	1201-41A2-1200-000	169,73 €
RFTF-U	0...100% r.H.	0...+50 °C	0-10V	0-10V		1201-41A1-1000-000	116,77 €
RFTF-U LCD	0...100% r.H.	0...+50 °C	0-10V	0-10V	■	1201-41A1-1200-000	169,73 €

HYGRASGARD® RFTF - U xx		Room humidity and temperature sensors					
Type/WG01	Measuring Range / Readout		Output			Item No.	Price
	Humidity	Temperature	Humidity	Temperature		(Baldur 1)	
<b>RFTF - U xx</b>							<b>(active / passive)</b>
<b>Pt, Ni, LM235Z</b>							
RFTF-U Pt100	0...100% r.H.	0...+50 °C	0-10V	0-10V + Pt100		1201-41A1-2001-000	155,50 €
RFTF-U Pt1000	0...100% r.H.	0...+50 °C	0-10V	0-10V + Pt1000		1201-41A1-2005-000	158,71 €
RFTF-U Ni1000	0...100% r.H.	0...+50 °C	0-10V	0-10V + Ni1000		1201-41A1-2009-000	159,80 €
RFTF-U NiTK	0...100% r.H.	0...+50 °C	0-10V	0-10V + Ni1000TK5000		1201-41A1-2010-000	160,03 €
RFTF-U LM235Z	0...100% r.H.	0...+50 °C	0-10V	0-10V + LM235Z, 10mV / K		1201-41A1-2021-000	159,43 €
<b>RFTF - U xx</b>							<b>(active / passive)</b>
<b>NTC</b>							
RFTF-U NTC1,8K	0...100% r.H.	0...+50 °C	0-10V	0-10V + NTC 1,8kOhm		1201-41A1-2012-000	159,92 €
RFTF-U NTC10K	0...100% r.H.	0...+50 °C	0-10V	0-10V + NTC 10kOhm		1201-41A1-2015-000	156,45 €
RFTF-U NTC20K	0...100% r.H.	0...+50 °C	0-10V	0-10V + NTC 20kOhm		1201-41A1-2016-000	156,45 €
Extra charge:	Two-line display with illumination						47,46 €



**Room humidity and temperature sensor or measuring transducer,  
in-wall in the panel switch programme,  
with active output**

The room sensor **HYGRASGARD® FSFM / FSFTM** in the in-wall housing is used for measuring the relative humidity and temperature of the air. It converts the measured values into a standard signal of 0-10 V.

A digital, long-term stable sensor is used for humidity and temperature measurement. Relative humidity [% r.H.] is the quotient of water vapour partial pressure divided by the saturation vapour pressure at the respective gas temperature.

The in-wall sensor is mounted in high-quality panel switch programmes, ideally of the brands Gira, Berker, Merten, Jung, Siemens or Busch-Jaeger (using in-wall adapters) either individually or in combination with light switches, socket outlets, etc.

It is used in non-aggressive, dust-free environments, in refrigeration, air conditioning and clean room technology, and in interior rooms, such as living rooms, offices, hotels, etc

Mounting diagram in-wall

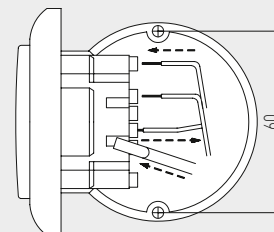

**TECHNICAL DATA**

Power supply:	24 V AC / DC (± 10 %)
Power consumption:	< 1.1 W / 24 V DC ; < 2.2 VA / 24 V AC

**HUMIDITY**

Sensor:	<b>digital humidity sensor, with integrated temperature sensor, low hysteresis, high long-term stability</b>
Long-term stability:	± 1 % per year
Measuring range, humidity:	0...100 % r.H.
Operating range, humidity:	0...95 % r.H. (non-precipitating air)
Deviation, humidity:	typically ± 3.0 % (20...80 % r.H.) at +25 °C, otherwise ± 5.0 %
Output, humidity:	0-10 V

**TEMPERATURE**

Measuring range:	0...+50 °C
Deviation, temperature:	typically ± 0.8 K at +25 °C
Output, temperature:	0-10 V

Mounting:	in-wall flush box Ø 55 mm
Electrical connection:	1.0-2.5 mm <sup>2</sup> , via plug terminals
Ambient temperature:	Storage -35...+85 °C; Operation 0...+50 °C
Permitted humidity:	max. 90 % r.H., non-precipitating air
Medium:	clean air and other non-aggressive, non-combustible gases
Protection class:	III (according to EN 60 730)
Protection type:	<b>IP 20</b> (according to 60 529)
Standards:	CE-conformity, electromagnetic compatibility according to EN 61 326, EMC Directive 2014 / 30 / EU

**SWITCH PROGRAMME**

Manufacturer:	GIRA System 55 (other switch programmes, manufacturers, colours as well as prices available upon request)
Housing:	plastic, the standard colour is pure glossy white (similar to RAL 9010) (other colours are available upon request with colour variants depending on the respective light switch programme)

Connection diagram FSFM

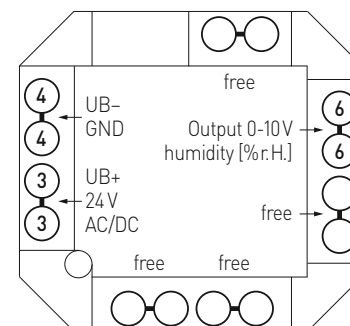

Connection diagram FSFTM

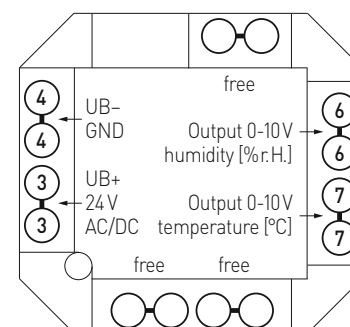



Dimensional drawing

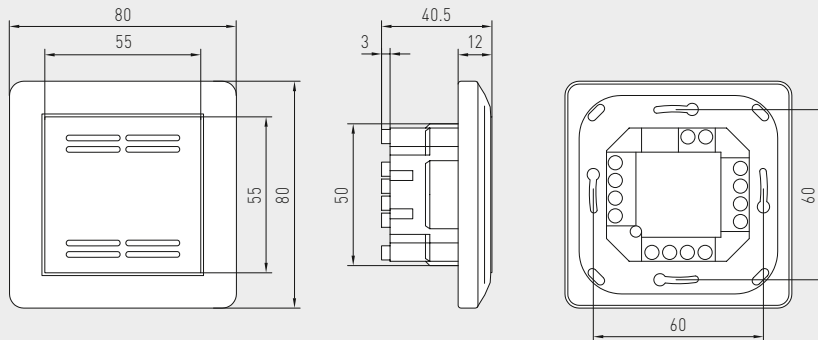

FSFM  
FSFTM

FSFM  
FSFTM



Humidity table

MR: 0...100% r. H.

% r.H.	U <sub>A</sub> [V]	% r.H.	U <sub>A</sub> [V]
0	0	50	5.0
5	0.5	55	5.5
10	1.0	60	6.0
15	1.5	65	6.5
20	2.0	70	7.0
25	2.5	75	7.5
30	3.0	80	8.0
35	3.5	85	8.5
40	4.0	90	9.0
45	4.5	95	9.5
Continued to the right ...		100	10.0

Temperature table

MR: 0...+50 °C

°C	U <sub>A</sub> [V]
0	0.0
5	1.0
10	2.0
15	3.0
20	4.0
25	5.0
30	6.0
35	7.0
40	8.0
45	9.0
50	10.0

HYGRASGARD® FSFM Room humidity sensor or measuring transducer, in-wall  
HYGRASGARD® FSFTM Room humidity and temperature sensor or measuring transducer, in-wall

Type / WG02	Measuring Range		Output		Item No.	Price
	Humidity	Temperature	Humidity	Temperature		
<b>FSFM</b>						
FSFM-U	0...100% r. H.	-	0-10 V	-	1201-9121-0000-162	228,09 €
<b>FSFTM</b>						
FSFTM-U	0...100% r. H.	0...+50 °C	0-10 V	0-10 V	1201-9121-1000-162	234,86 €

**In-ceiling humidity and temperature sensors ( $\pm 2.0\%$ ),  
calibratable, with multi-range switching  
and active output**

The calibratable humidity and temperature sensor **HYGRASGARD® DFF / DFTF** measures the relative humidity and temperature of air. It converts the measurands into a standard signal of 0-10V or 4...20mA, and is available with / without an optional display.

It is equipped with four switchable temperature ranges. Relative humidity (in % r.H.) is the quotient of water vapour partial pressure divided by the saturation vapour pressure at the respective gas temperature. The measuring transducers are designed for exact detection of temperature and humidity. A digital, long-term stable sensor is used as a measuring element for humidity and temperature measurement. The sensor is factory-calibrated; an environmental precision adjustment by an expert is possible.

The ceiling-installed sensor is used in non-aggressive, dust-free environments and is used for installation in suspended ceilings in corridors, offices, as well as in residential and commercial buildings. The connecting head is pluggable for quick, easy mounting. The measuring transducer is accommodated in a separate housing.

**DFF  
DFTF**



#### TECHNICAL DATA

Power supply:	24 V AC ( $\pm 20\%$ ) and 15...36 V DC for U variant 15...36 V DC for I variant, depending on working resistance, residual ripple stabilised $\pm 0.3$ V
Working resistance:	$R_B$ (Ohm) = $(U_B - 14 \text{ V}) / 0.02 \text{ A}$ for I variant
Load resistance:	$R_L > 5 \text{ kOhm}$ for U variant
Power consumption:	$< 1.1 \text{ VA} / 24 \text{ V DC}$ ; $< 2.2 \text{ VA} / 24 \text{ V AC}$
Sensors:	<b>digital humidity sensor with integrated temperature sensor,</b> low hysteresis, high long-term stability

#### HUMIDITY

Measuring range, humidity:	0...100% r.H. (output corresponding to 0-10V or 4...20mA)
Operating range, humidity:	0...95% r.H. (without formation of dew)
Deviation in humidity:	typically $\pm 2.0\%$ (20...80% r.H.) at $+25^\circ\text{C}$ , otherwise $\pm 3.0\%$
Output, humidity:	0-10V for U variant 4...20 mA for I variant, see load resistance diagram

#### TEMPERATURE

Measuring range, temperature:	<b>multi-range switching with 4 switchable measuring ranges</b> (see table) $-35...+35^\circ\text{C}$ ; $-35...+75^\circ\text{C}$ ; $0...+50^\circ\text{C}$ ; $0...+80^\circ\text{C}$ (output corresponding to 0-10V or 4...20mA)
Deviation temperature:	typically $\pm 0.2 \text{ K}$ at $+25^\circ\text{C}$
Output, temperature:	0-10V or 4...20mA
Ambient temperature:	storage $-5...+60^\circ\text{C}$ ; operation $-5...+60^\circ\text{C}$
Long-term stability:	$\pm 1\%$ per year
Housing:	plastic, UV-resistant, material polyamide, 30% glass-globe reinforced, with quick-locking screws (slotted / Phillips head combination), colour traffic white (similar to RAL 9016), housing cover for display is transparent!
Housing dimensions:	72 x 64 x 37.8 mm (Tyr 1 without display) 72 x 64 x 43.3 mm (Tyr 1 with display)
Cable connection:	<b>cable gland</b> , plastic (M 16 x 1.5; with strain relief, exchangeable, max. inner diameter 10.4 mm) <b>or</b> <b>M12 connector</b> according to DIN EN 61076-2-101 (optional on request)
Electrical connection:	2-, 3- or 4-wire (see connecting diagram), 0.14 - 1.5 mm <sup>2</sup> , via terminal screws
Connecting cable:	PVC, LiYY, 4 x 0.14 mm <sup>2</sup> , cable length (KL) = approx. 2 m
Connecting head:	made of plastic, material polycarbonate (PC), colour white, <b>pluggable</b> , $\varnothing$ = approx. 35 mm, H = approx. 29 mm, with metal sinter filter made of stainless steel <b>V4A</b> (1.4404)
Mounting (sensor):	in the suspended ceiling, ceiling cut-out $\varnothing = 30 \text{ mm}$ , cover $\varnothing < 35 \text{ mm}$
Protection class:	III (according to EN 60 730)
Protection type:	<b>IP 67</b> (according EN 60 529) Housing tested TÜV SÜD, Report No. 713139052 <b>IP 30</b> (according EN 60 529) Sensor in the built-in state
Standards:	CE conformity according to EMC Directive 2014 / 30 / EU, according to EN 61326-1, according to EN 61326-2-3
Optional:	two-line <b>display with illumination</b> , cutout approx. 36 x 15 mm (W x H), to display the ACTUAL temperature and / or ACTUAL humidity

**DFF  
DFTF**  
Connecting head,  
pluggable





Dimensional drawing

DFF  
DFTF

DFF  
DFTF  
with display

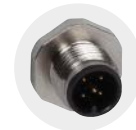
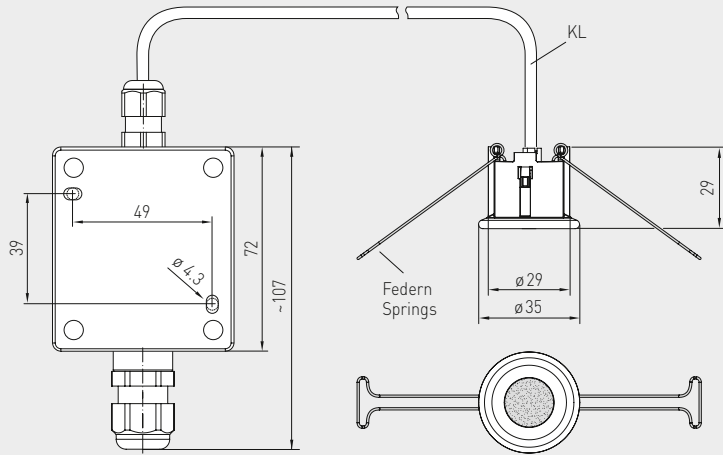
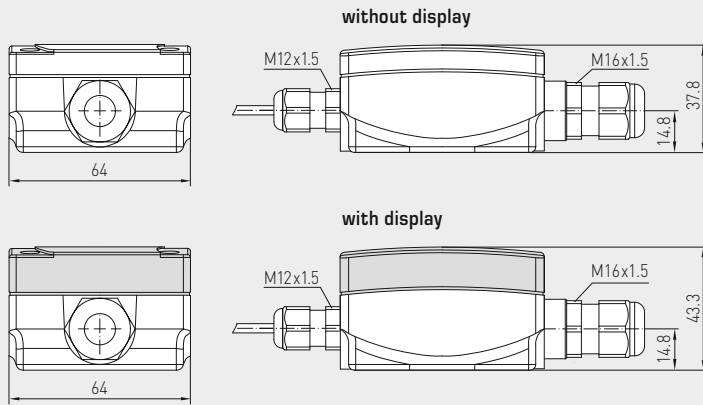

M12 connector  
(optional on request)

Temperature table  
MR: -35...+75 °C

°C	U <sub>A</sub> in V	I <sub>A</sub> in mA
-35	0.0	4.0
-30	0.5	4.7
-25	0.9	5.5
-20	1.4	6.2
-15	1.8	6.9
-10	2.3	7.6
-5	2.7	8.4
0	3.2	9.1
5	3.6	9.8
10	4.1	10.5
15	4.5	11.3
20	5.0	12.0
25	5.5	12.7
30	5.9	13.5
35	6.4	14.2
40	6.8	14.9
45	7.3	15.6
50	7.7	16.4
55	8.2	17.1
60	8.6	17.8
65	9.1	18.5
70	9.5	19.2
75	10.0	20.0

Temperature table  
MR: -35...+35 °C

°C	U <sub>A</sub> in V	I <sub>A</sub> in mA
-35	0.0	4.0
-30	0.7	5.1
-25	1.4	6.3
-20	2.1	7.4
-15	2.9	8.6
-10	3.6	9.7
-5	4.3	10.9
0	5.0	12.0
5	5.7	13.1
10	6.4	14.3
15	7.1	15.4
20	7.9	16.6
25	8.6	17.7
30	9.3	18.9
35	10.0	20.0

Temperature table  
MR: 0...+50 °C

°C	U <sub>A</sub> in V	I <sub>A</sub> in mA
0	0.0	4.0
5	1.0	5.6
10	2.0	7.2
15	3.0	8.8
20	4.0	10.4
25	5.0	12.0
30	6.0	13.6
35	7.0	15.2
40	8.0	16.8
45	9.0	18.4
50	10.0	20.0

Temperature table  
MR: 0...+80 °C

°C	U <sub>A</sub> in V	I <sub>A</sub> in mA
0	0.0	4.0
5	0.6	5.0
10	1.3	6.0
15	1.9	7.0
20	2.5	8.0
25	3.1	9.0
30	3.8	10.0
35	4.4	11.0
40	5.0	12.0
45	5.6	13.0
50	6.3	14.0
55	6.9	15.0
60	7.5	16.0
65	8.1	17.0
70	8.8	18.0
75	9.4	19.0
80	10.0	20.0

Humidity table  
MR: 0...100% r. H.

% r.H.	U <sub>A</sub> in V	I <sub>A</sub> in mA
0	0.0	4.0
5	0.5	4.8
10	1.0	5.6
15	1.5	6.4
20	2.0	7.2
25	2.5	8.0
30	3.0	8.8
35	3.5	9.6
40	4.0	10.4
45	4.5	11.2
50	5.0	12.0
55	5.5	12.8
60	6.0	13.6
65	6.5	14.4
70	7.0	15.2
75	7.5	16.0
80	8.0	16.8
85	8.5	17.6
90	9.0	18.4
95	9.5	19.2
100	10.0	20.0

In-ceiling humidity and temperature sensors ( $\pm 2.0\%$ ),  
calibratable, with multi-range switching  
and active output

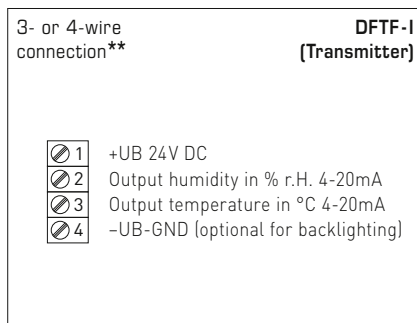
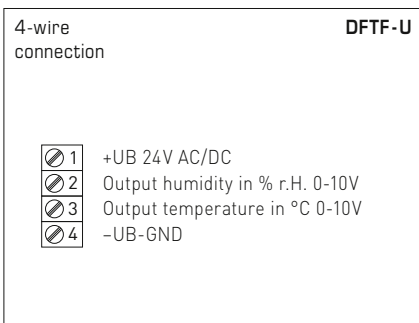
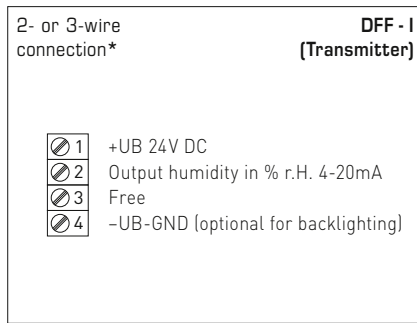
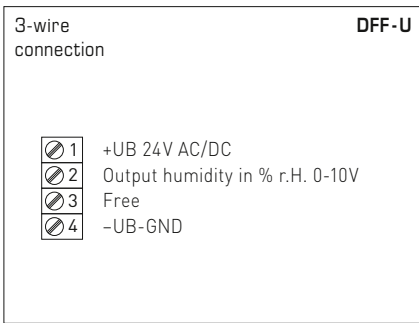
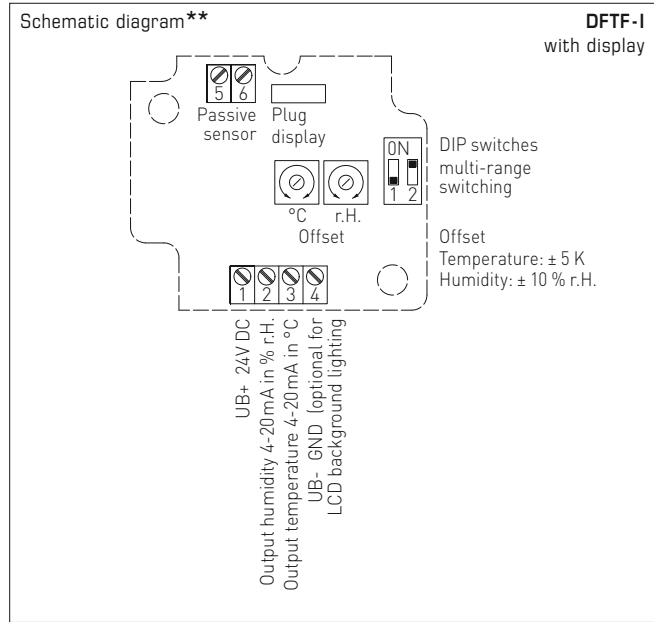
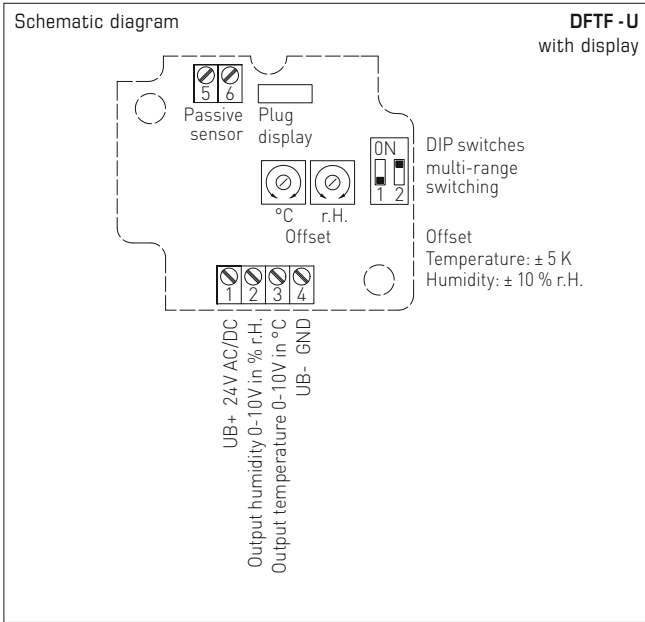

Temperature measuring ranges (adjustable)	DIP 1	DIP 2
-35...+75 °C	ON	ON
-35...+35 °C	OFF	OFF
0...+50 °C (default)	OFF	ON
0...+80 °C	ON	OFF

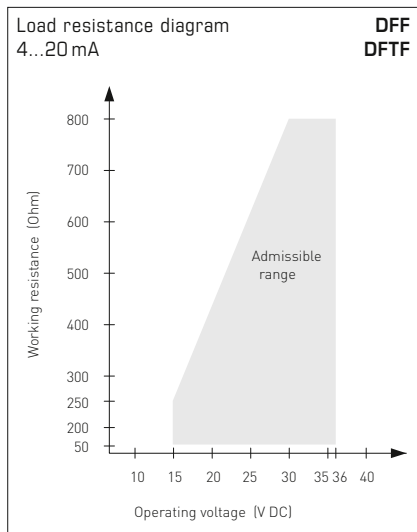

Connection\*:  
2-wire connection for devices with / without display (not illuminated)  
3-wire connection for devices with illuminated display

Connection\*\*:  
3-wire connection for devices with / without display (not illuminated)  
4-wire connection for devices with illuminated display

For the **I variant** the humidity path must be connected!





S+S REGELTECHNIK

HYGRASGARD® DFF  
HYGRASGARD® DFTF

In-ceiling humidity and temperature sensors ( $\pm 2.0\%$ ),  
calibratable, with multi-range switching  
and active output

DFF  
DFTF  
with display



HYGRASGARD® DFF		In-ceiling humidity sensors ( $\pm 2.0\%$ ), Premium				
HYGRASGARD® DFTF		In-ceiling humidity and temperature sensors ( $\pm 2.0\%$ ), Premium				
Type / WG01	Measuring Range / Readout	Output	Display	Item No.	Price	
	Humidity	Humidity	Humidity			
	Temperature	Temperature	Temperature			
<b>DFF-I</b>						
<b>I-variant</b>						
DFF-I	0...100% r. H.	–	4...20mA	–	1201-6132-0000-100 <b>326,32 €</b>	
DFF-I LCD	0...100% r. H.	–	4...20mA	–	■ 1201-6132-0200-100 <b>381,65 €</b>	
<b>DFF-U</b>						
<b>U-variant</b>						
DFF-U	0...100% r. H.	–	0-10V	–	1201-6131-0000-100 <b>326,32 €</b>	
DFF-U LCD	0...100% r. H.	–	0-10V	–	■ 1201-6131-0200-100 <b>381,65 €</b>	
<b>DFTF-I</b>						
<b>I-variant</b>						
DFTF-I	0...100% r. H.	–35...+75 °C –35...+35 °C 0...+50 °C 0...+80 °C	4...20mA	4...20mA	1201-6132-1000-100 <b>334,23 €</b>	
DFTF-I LCD	0...100% r. H.	(4x as above)	4...20mA	4...20mA	■ 1201-6132-1200-100 <b>389,56 €</b>	
<b>DFTF-U</b>						
<b>U-variant</b>						
DFTF-U	0...100% r. H.	–35...+75 °C –35...+35 °C 0...+50 °C 0...+80 °C	0-10V	0-10V	1201-6131-1000-100 <b>334,23 €</b>	
DFTF-U LCD	0...100% r. H.	(4x as above)	0-10V	0-10V	■ 1201-6131-1200-100 <b>389,56 €</b>	
Optional:	Cable connection with <b>M12 connector</b> according to DIN EN 61076-2-101				on request	

**On-wall humidity and temperature sensors ( $\pm 2.0\%$ ), compact form, calibratable, with multi-range switching and active output**

The calibratable outdoor humidity/temperature sensors **HYGRASGARD® AFF-SD/AFTF-SD** measure the relative humidity and/or temperature of air. They convert the measurands into standard signals of 0-10 V or 4...20 mA and are available with or without an optional display. Terminal box housing made of impact-resistant plastic with housing cover with quick-locking screws. They have four switchable temperature ranges and are applied in non-aggressive dust-free atmospheres in refrigeration, air conditioning, ventilation and clean room technology. Relative humidity (in % r.H.) is the quotient of water vapour partial pressure divided by the saturation vapour pressure at the respective gas temperature. These measuring transducers are designed for precise detection of humidity. A digital long-term stable sensor is used as a measuring element for humidity measurement. The sensor is factory-calibrated; an environmental precision adjustment by an expert is possible.

**AFF-SD**  
**AFTF-SD**  
compact form



**SF-M**  
Metal sinter filter (optional)



#### TECHNICAL DATA

Power supply:	24 V AC ( $\pm 20\%$ ); 15...36 V DC for U variant 15...36 V DC for I variant, depending on working resistance, residual ripple stabilised $\pm 0.3$ V
Working resistance:	$R_a$ (ohm) = $(U_b - 14 \text{ V}) / 0.02 \text{ A}$ for I variant
Load resistance:	$R_L > 5 \text{ kOhm}$ for U variant
Power consumption:	$< 1.1 \text{ VA} / 24 \text{ V DC}$ ; $< 2.2 \text{ VA} / 24 \text{ V AC}$
Sensors:	<b>digital humidity sensor with integrated temperature sensor,</b> low hysteresis, high long-term stability
Sensor protection:	<b>plastic</b> sinter filter, $\varnothing 16 \text{ mm}$ , $L = 35 \text{ mm}$ , exchangeable (optional <b>metal</b> sinter filter, $\varnothing 16 \text{ mm}$ , $L = 32 \text{ mm}$ )
<b>HUMIDITY</b>	
Measuring range, humidity:	0...100% r.H. (output corresponding to 0-10 V or 4...20 mA)
Operating range, humidity:	0...95% r.H. (without dew formation)
Deviation, humidity:	typically $\pm 2.0\%$ (20...80% r.H.) at $+25^\circ\text{C}$ , otherwise $\pm 3.0\%$
Output, humidity:	0-10 V for U variant 4...20 mA for I variant, see load resistance diagram
<b>TEMPERATURE</b>	
Measuring range, temperature:	<b>multi-range switching</b> (see table) <b><math>-35...+35^\circ\text{C}</math>; <math>-35...+75^\circ\text{C}</math>; <math>0...+50^\circ\text{C}</math>; <math>0...+80^\circ\text{C}</math></b> (output corresponding to 0-10 V or 4...20 mA)
Deviation, temperature:	typically $\pm 0.6 \text{ K}$ at $+25^\circ\text{C}$
Output, temperature:	0-10 V or 4...20 mA or Ohm value
Ambient temperature:	storage $-35...+85^\circ\text{C}$ , operation $-30...+70^\circ\text{C}$ , non-precipitating
Electrical connection:	2-, 3-, or 4-wire connection (see connecting diagram), 0.14 - 1.5 mm <sup>2</sup> , via terminal screws
Housing:	plastic, UV-resistant, material polyamide, 30% glass-globe reinforced, with quick-locking screws (slotted/Phillips head combination), colour traffic white (similar to RAL 9016), housing cover for display is transparent!
Housing dimensions:	72 x 64 x 37.8 mm (Tyr 1 without display) 72 x 64 x 43.3 mm (Tyr 1 with display)
Cable connection:	<b>cable gland</b> , plastic (M 16 x 1.5; with strain relief, exchangeable, max. inner diameter 10.4 mm) or <b>M12 connector</b> according to DIN EN 61076-2-101 (optional on request)
Protective tube:	<b>stainless steel V2A</b> (1.4301), $\varnothing = 16 \text{ mm}$ , $NL = 55 \text{ mm}$
Process connection:	by screws
Long-term stability:	$\pm 1\%$ per year
Protection class:	III (according to EN 60 730)
Protection type:	<b>IP 65</b> (according to EN 60 529) Housing tested, TÜV SÜD, Report No. 713139052 (Tyr 1)
Standards:	CE conformity, according to EMC directive 2014/30/EU, according to EN 61326-1, according to EN 61326-2-3
Optional:	two-line <b>display with illumination</b> , cutout approx. 36 x 15 mm (W x H), for displaying ACTUAL temperature and/or ACTUAL humidity
<b>ACCESSORIES</b>	see last chapter



Dimensional drawing

AFF-SD  
AFTF-SD

AFF-SD  
AFTF-SD  
compact form  
with display

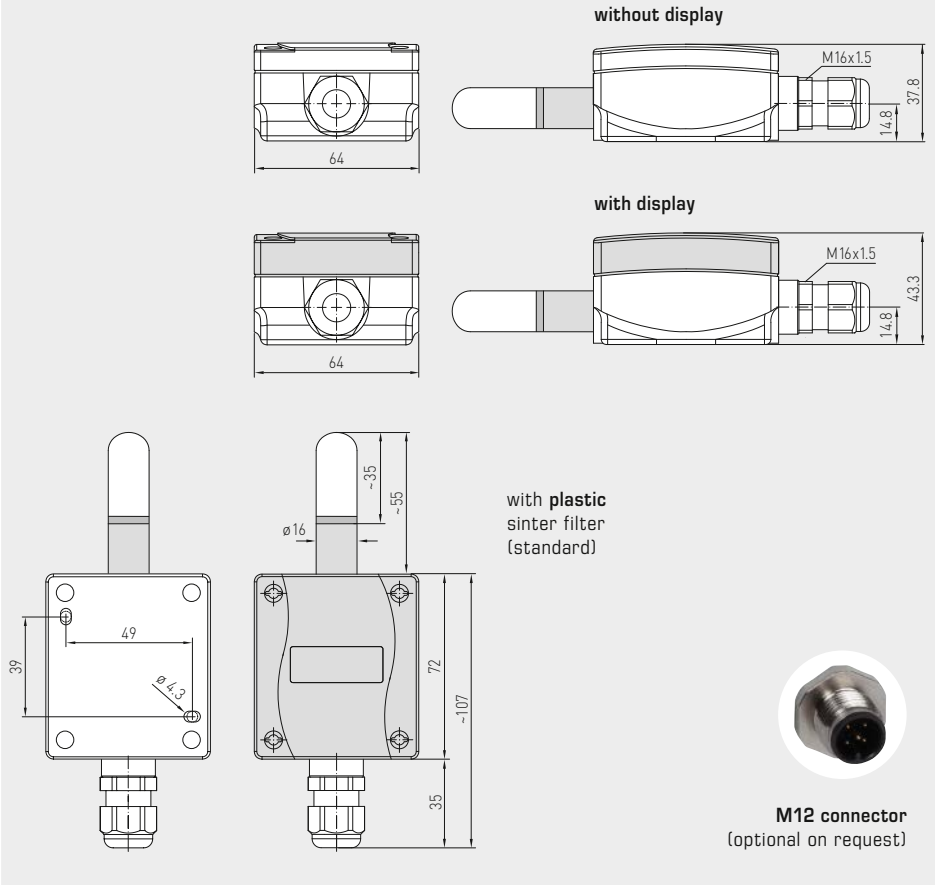

SF-M  
Metal sinter filter  
(optional)



Temperature table  
MR: -35...+75 °C

°C	U <sub>A</sub> in V	I <sub>A</sub> in mA
-35	0.0	4.0
-30	0.5	4.7
-25	0.9	5.5
-20	1.4	6.2
-15	1.8	6.9
-10	2.3	7.6
-5	2.7	8.4
0	3.2	9.1
5	3.6	9.8
10	4.1	10.5
15	4.5	11.3
20	5.0	12.0
25	5.5	12.7
30	5.9	13.5
35	6.4	14.2
40	6.8	14.9
45	7.3	15.6
50	7.7	16.4
55	8.2	17.1
60	8.6	17.8
65	9.1	18.5
70	9.5	19.2
75	10.0	20.0

Temperature table  
MR: -35...+35 °C

°C	U <sub>A</sub> in V	I <sub>A</sub> in mA
-35	0.0	4.0
-30	0.7	5.1
-25	1.4	6.3
-20	2.1	7.4
-15	2.9	8.6
-10	3.6	9.7
-5	4.3	10.9
0	5.0	12.0
5	5.7	13.1
10	6.4	14.3
15	7.1	15.4
20	7.9	16.6
25	8.6	17.7
30	9.3	18.9
35	10.0	20.0

Temperature table  
MR: 0...+50 °C

°C	U <sub>A</sub> in V	I <sub>A</sub> in mA
0	0.0	4.0
5	1.0	5.6
10	2.0	7.2
15	3.0	8.8
20	4.0	10.4
25	5.0	12.0
30	6.0	13.6
35	7.0	15.2
40	8.0	16.8
45	9.0	18.4
50	10.0	20.0

Temperature table  
MR: 0...+80 °C

°C	U <sub>A</sub> in V	I <sub>A</sub> in mA
0	0.0	4.0
5	0.6	5.0
10	1.3	6.0
15	1.9	7.0
20	2.5	8.0
25	3.1	9.0
30	3.8	10.0
35	4.4	11.0
40	5.0	12.0
45	5.6	13.0
50	6.3	14.0
55	6.9	15.0
60	7.5	16.0
65	8.1	17.0
70	8.8	18.0
75	9.4	19.0
80	10.0	20.0

Humidity table  
MR: 0...100% r. H.

% r.H.	U <sub>A</sub> in V	I <sub>A</sub> in mA
0	0.0	4.0
5	0.5	4.8
10	1.0	5.6
15	1.5	6.4
20	2.0	7.2
25	2.5	8.0
30	3.0	8.8
35	3.5	9.6
40	4.0	10.4
45	4.5	11.2
50	5.0	12.0
55	5.5	12.8
60	6.0	13.6
65	6.5	14.4
70	7.0	15.2
75	7.5	16.0
80	8.0	16.8
85	8.5	17.6
90	9.0	18.4
95	9.5	19.2
100	10.0	20.0

On-wall humidity and temperature sensors ( $\pm 2.0\%$ ), compact form, calibratable, with multi-range switching and active output

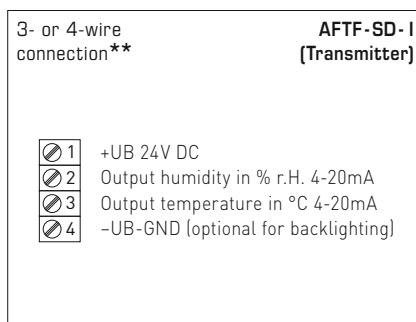
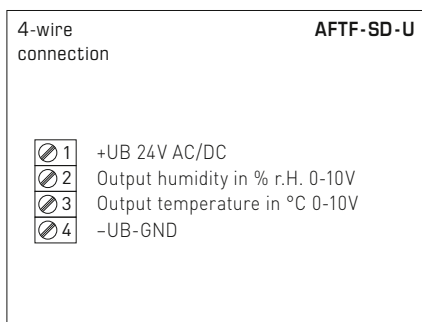
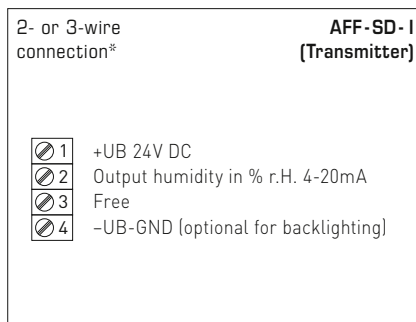
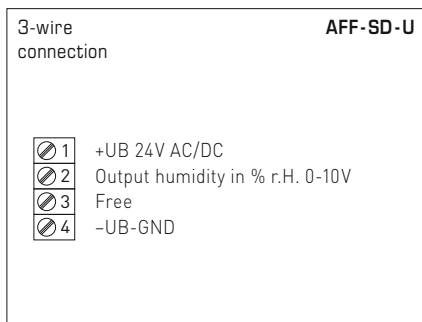
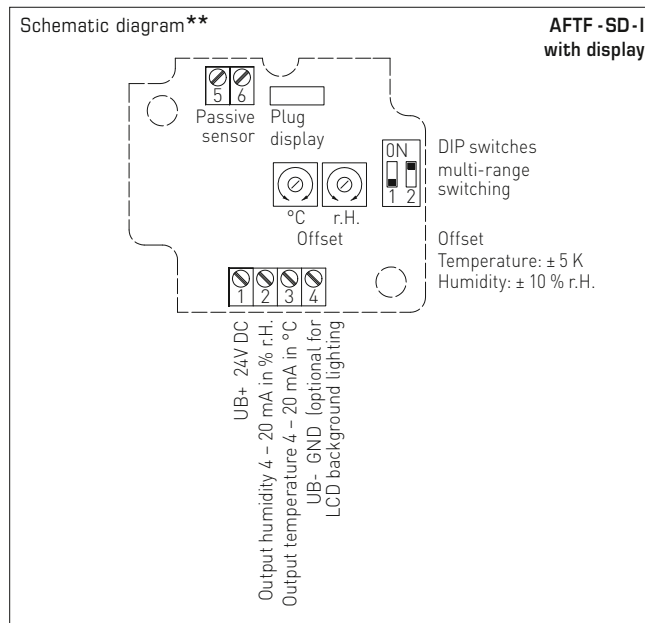
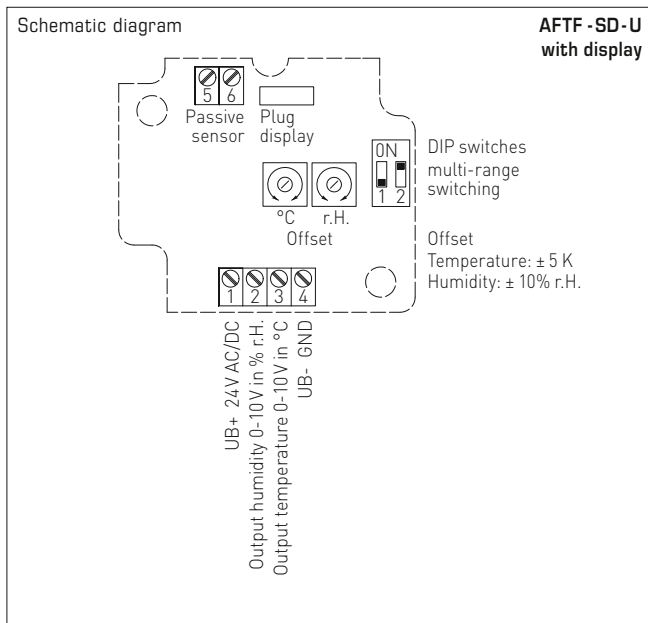

Temperature measuring ranges (adjustable)	DIP 1	DIP 2
-35...+75 °C	ON	ON
-35...+35 °C	OFF	OFF
0...+50 °C (default)	OFF	ON
0...+80 °C	ON	OFF

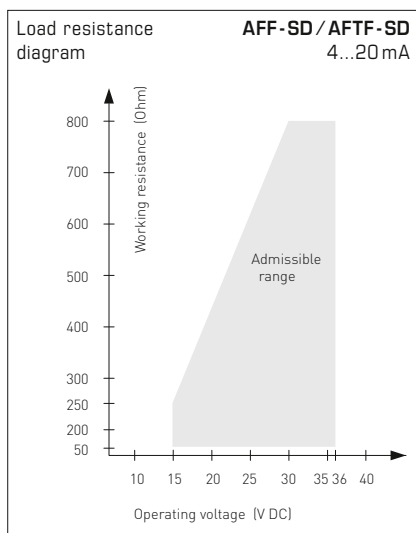

Connection\*:  
2-wire connection for devices with / without display (not illuminated)  
3-wire connection for devices with illuminated display

Connection\*\*:  
3-wire connection for devices with / without display (not illuminated)  
4-wire connection for devices with illuminated display

For the I variant the humidity path must be connected!



**WS-04**

Weather and sun protection hood  
(optional)



**AFF-SD**  
**AFTF-SD**  
compact form  
with display

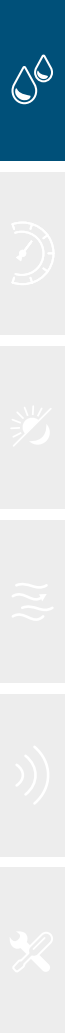

**HYGRASGARD® AFF-SD** On-wall humidity sensors, compact form ( $\pm 2.0\%$ ), *Standard*  
**HYGRASGARD® AFTF-SD** On-wall humidity and temperature sensors, compact form ( $\pm 2.0\%$ ), *Standard*

Type/ WG01B	Measuring Range/ Readout		Output		Display	Item No.	Price
	Humidity	Temperature	Humidity	Temperature			
<b>AFF-SD-I</b>							<b>I-variant</b>
AFF-SD-I	0...100% r. H.	-	4...20 mA	-		1201-1122-0000-100	172,16 €
AFF-SD-I LCD	0...100% r. H.	-	4...20 mA	-	■	1201-1122-0200-000	220,67 €
<b>AFF-SD-U</b>							<b>U-variant</b>
AFF-SD-U	0...100% r. H.	-	0-10 V	-		1201-1121-0000-100	172,16 €
AFF-SD-U LCD	0...100% r. H.	-	0-10 V	-	■	1201-1121-0200-000	220,67 €
<b>AFTF-SD-I</b>							<b>I-variant</b>
AFTF-SD-I	0...100% r. H.	-35...+75 °C -35...+35 °C 0...+50 °C 0...+80 °C	4...20 mA	4...20 mA		1201-1122-1000-100	175,80 €
AFTF-SD-I LCD	0...100% r. H.	-35...+75 °C -35...+35 °C 0...+50 °C 0...+80 °C	4...20 mA	4...20 mA	■	1201-1122-1200-100	224,29 €
<b>AFTF-SD-U</b>							<b>U-variant</b>
AFTF-SD-U	0...100% r. H.	-35...+75 °C -35...+35 °C 0...+50 °C 0...+80 °C	0-10 V	0-10 V		1201-1121-1000-100	175,80 €
AFTF-SD-U LCD	0...100% r. H.	-35...+75 °C -35...+35 °C 0...+50 °C 0...+80 °C	0-10 V	0-10 V	■	1201-1121-1200-100	224,29 €
Optional:	Cable connection with <b>M12 connector</b> according to DIN EN 61076-2-101						on request

<b>ACCESSORIES</b>								
<b>SF-M</b>	Metal sinter filter, $\varnothing$ 16 mm, L=32 mm, exchangeable stainless steel <b>V4A</b> (1.4404)						7000-0050-2200-100	40,31 €
<b>WS-01</b>	Sun and ball-impact protection hood, 184 x 180 x 80 mm, stainless steel <b>V2A</b> (1.4301)						7100-0040-2000-000	30,26 €
<b>WS-04</b>	Weather and sun protection hood, 130x180x135 mm, stainless steel <b>V2A</b> (1.4301)						7100-0040-7000-000	35,70 €
For further information, see last chapter Accessories!								



**On-wall humidity and temperature sensors ( $\pm 1.8\%$  /  $\pm 2.0\%$ ),  
calibratable, with multi-range switching  
and active/passive output**

Calibratable outdoor humidity/temperature sensor **HYGRASGARD® AFF/AFTF** ( $\pm 2.0\%$ ) and **AFF-20/AFTF-20** ( $\pm 1.8\%$ ) with plastic sinter filter (optional metal sinter filter) or **AFF-25/AFTF-25** ( $\pm 1.8\%$ ) with **pluggable measuring head** with metal sinter filter; housing made of impact-resistant plastic with quick-locking screws, optionally with /without display, with cable gland (optional M12 connector according to DIN EN 61076-2-101).

It measures the relative humidity and/or temperature of the air and converts the measurand into a standard signal of 0 - 10V or 4...20 mA. They have four switchable temperature ranges and are applied in non-aggressive, dust-free atmospheres in refrigeration, air conditioning, ventilation and clean room technology. Relative humidity (in % r. H.) is the quotient of water vapour partial pressure divided by the saturation vapour pressure at the respective gas temperature. These measuring transducers are designed for exact detection of humidity. A digital long-term stable sensor is used as measuring element for humidity measurement. The sensor is factory-calibrated; an environmental precision adjustment by an expert is possible.

**AFF / AFTF ( $\pm 2.0\%$ )**  
with plastic sinter filter  
(standard)



**AFF-20 / AFTF-20 ( $\pm 1.8\%$ )**  
with plastic sinter filter  
(standard)



**AFF-25 / AFTF-25 ( $\pm 1.8\%$ )**  
**pluggable measuring head**  
with metal sinter filter



#### TECHNICAL DATA

Power supply: 24 V AC ( $\pm 20\%$ ); 15...36 V DC for U variant  
15...36 V DC for I variant,  
depending on working resistance, residual ripple stabilised  $\pm 0.3$  V

Working resistance:  $R_b$  (ohm) =  $(U_b - 14 V) / 0.02 A$  for I variant, see load resistance diagram

Load resistance:  $R_L > 5 k\Omega$  for U variant

Power consumption:  $< 1.1 VA / 24 V DC$ ;  $< 2.2 VA / 24 V AC$

Sensors: **digital humidity sensor with integrated temperature sensor**,  
low hysteresis, high long-term stability

#### HUMIDITY

Measuring range, humidity: 0...100% r. H.

Permitted humidity:  $< 95\%$  r. H., non-precipitating air

Deviation in humidity: **AFF / AFTF:**  
typically  $\pm 2.0\%$  (20...80% r. H.) at  $+25^\circ C$ , otherwise  $\pm 3.0\%$   
**AFF-20 / AFTF-20, AFF-25 / AFTF-25:**  
typically  $\pm 1.8\%$  (10...90% r. H.) at  $+25^\circ C$ , otherwise  $\pm 2.0\%$

Output humidity: 0-10 V for U variant; 4...20 mA for I variant

#### TEMPERATURE

Measuring range, temperature: **multi-range switching** (see table)  
 **$-35...+35^\circ C$ ;  $-35...+75^\circ C$ ;  $0...+50^\circ C$ ;  $0...+80^\circ C$**

Ambient temperature: storage  $-35...+85^\circ C$ ; operation  $-30...+80^\circ C$ , non-precipitating

Deviation, temperature: **AFF / AFTF:**  
typically  $\pm 0.4 K$  at  $+25^\circ C$

**AFF-20 / AFTF-20, AFF-25 / AFTF-25:**  
typically  $\pm 0.2 K$  at  $+25^\circ C$

Output, temperature: 0-10 V for U variant; 4...20 mA for I variant;  
**AFTF-Uxx** (passive temperature sensor) see table

Electrical connection: 2-, 3-, or 4-wire connection (see connecting diagram),  
0.14 - 1.5 mm<sup>2</sup>, via terminal screws

Cable connection: **cable gland**, plastic (M 16 x 1.5; with strain relief,  
exchangeable, max. inner diameter 10.4 mm) or  
**M12 connector** according to DIN EN 61076-2-101 (optional)

Housing: plastic, UV-resistant, material polyamide, 30% glass-globe reinforced,  
with quick-locking screws (slotted / Phillips head combination),  
colour traffic white (similar to RAL 9016),  
housing cover for display is transparent!

Housing dimensions: 126 x 90 x 50 mm (Tyr2)

Protective tube: **stainless steel V2A** (1.4301),  $\varnothing$  16 mm  
**AFF / AFTF:** NL = 55 mm  
**AFF-20 / AFTF-20:** NL = 137 mm  
**AFF-25 / AFTF-25:** NL = 88.5 mm

Sensor protection: **AFF / AFTF, AFF-20 / AFTF-20:**  
**plastic sinter filter**,  $\varnothing$  16 mm, L = 35 mm, exchangeable  
(optional metal sinter filter,  $\varnothing$  16 mm, L = 32 mm)

**AFF-25 / AFTF-25:**  
**pluggable measuring head** (probe), stainless steel V2A (1.4301),  
with metal sinter filter,  $\varnothing$  16 mm, L = 88.5 mm, exchangeable

Process connection: by screws

Long-term stability:  $\pm 1\%$  per year

Protection class: III (according to EN 60 730)

Protection type: **IP 65** (according to EN 60 529)

Standards: CE conformity, according to EMC directive 2014 / 30 / EU,  
according to EN 61326-1, according to EN 61326-2-3

Optional: three-line **display with illumination**, cutout 70 x 40 mm (W x H),  
for displaying ACTUAL temperature and / or ACTUAL humidity

#### ACCESSORIES

see last chapter



Dimensional drawing

AFF / AFTF  
AFF-20 / AFTF-20

AFF / AFTF ( $\pm 2.0\%$ )  
with display and  
plastic sinter filter  
(standard)

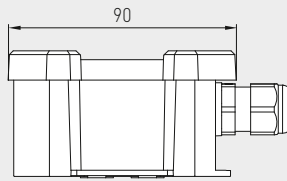
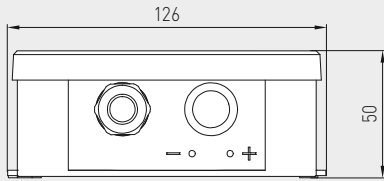

AFF / AFTF

AFF-20 / AFTF-20

AFF-20 / AFTF-20 ( $\pm 1.8\%$ )  
with display and  
plastic sinter filter  
(standard)

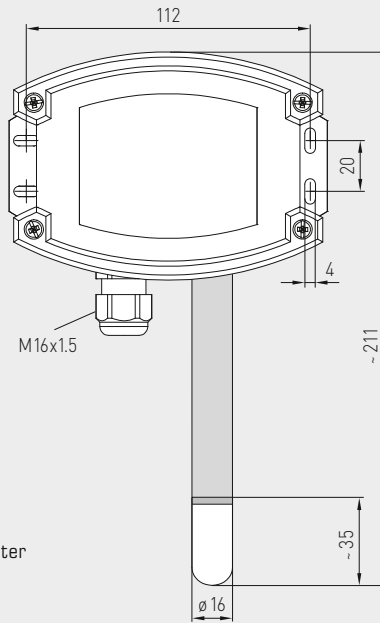
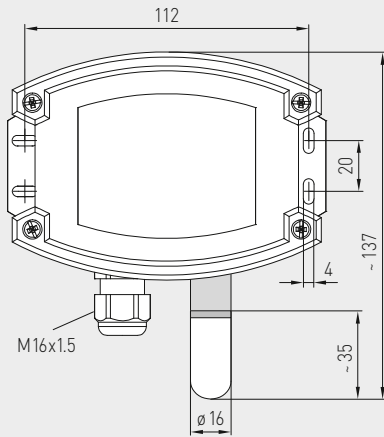

SF-K  
Plastic sinter filter  
(standard)



SF-M  
Metal sinter filter  
(optional)



M12 connector  
(optional)

Dimensional drawing

AFF-25 / AFTF-25

AFF-25 / AFTF-25 ( $\pm 1.8\%$ )  
pluggable measuring head  
with metal sinter filter  
and display

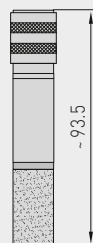
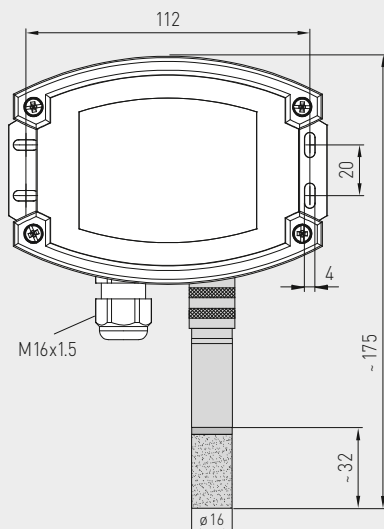

pluggable  
measuring head  
with metal  
sinter filter



On-wall humidity and temperature sensors ( $\pm 1.8\%$  /  $\pm 2.0\%$ ),  
 calibratable, with multi-range switching  
 and active/passive output

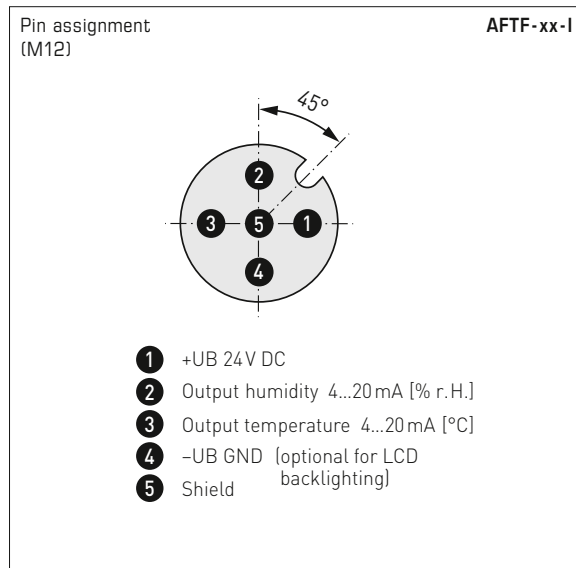
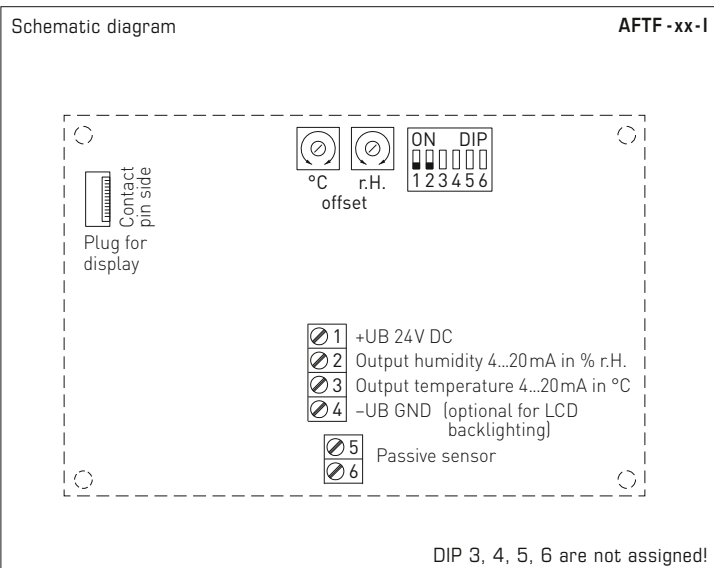
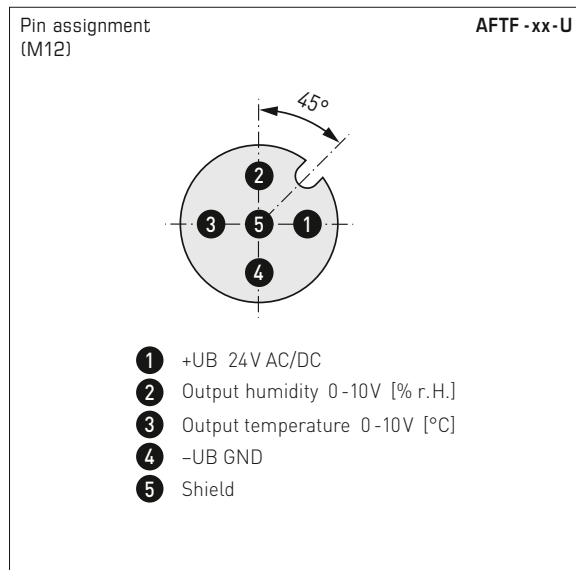
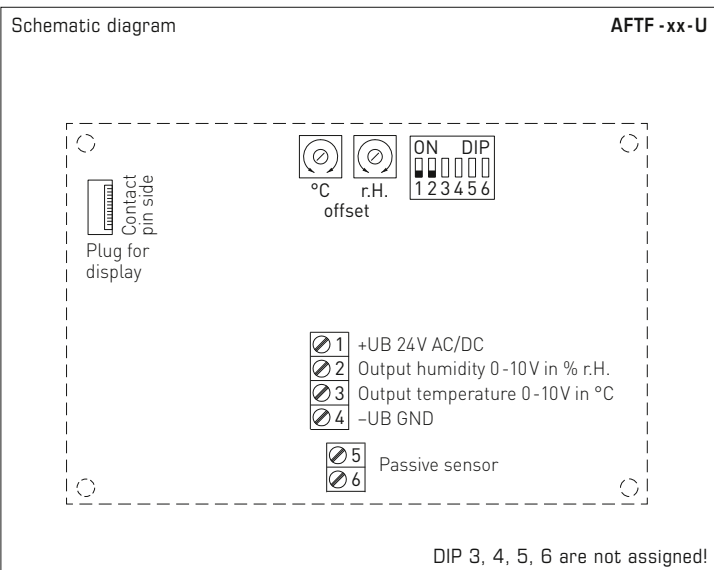

**AFF-xx / AFTF-xx**  
 with display,  
 hinged

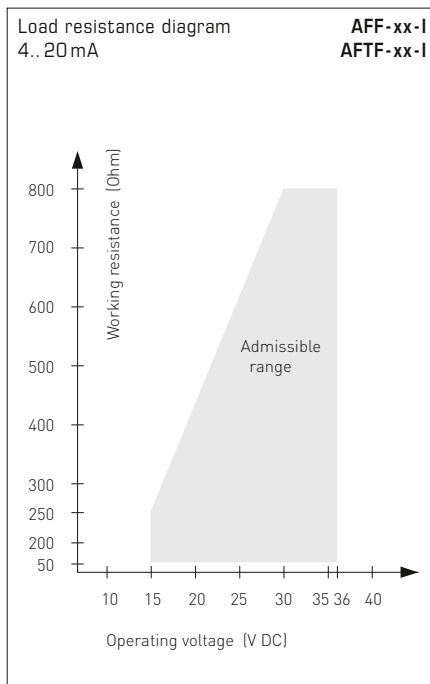



**3-wire connection** **AFF-xx-U**

1	+UB 24V AC/DC
2	Output humidity in % r.H. 0-10V
3	Free
4	-UB-GND

**2- or 3-wire connection \*** **AFF-xx-I (Transmitter)**

1	+UB 24V DC
2	Output humidity in % r.H. 4...20mA
3	Free
4	-UB-GND (optional for backlighting)

**4- or 6-wire connection** **AFTF-U (passive temperature sensor)**

1	+UB 24V AC/DC
2	Output humidity in % r.H. 0-10V
3	Output temperature in °C 0-10V
4	-UB-GND
5	Passive element
6	e.g. Pt1000, Ni1000, LMZ235Z

**4-wire connection** **AFTF-xx-U**

1	+UB 24V AC/DC
2	Output humidity in % r.H. 0-10V
3	Output temperature in °C 0-10V
4	-UB-GND

**3- or 4-wire connection \*\*** **AFTF-xx-I (Transmitter)**

1	+UB 24V DC
2	Output humidity in % r.H. 4...20mA
3	Output temperature in °C 4...20mA
4	-UB-GND (optional for backlighting)

**4- or 6-wire connection** **AFTF-I (passive temperature sensor)**

1	+UB 24V DC
2	Output humidity in % r.H. 4...20mA
3	Output temperature in °C 4...20mA
4	-UB-GND (optional for backlighting)
5	Passive element
6	e.g. Pt1000, Ni1000, LMZ235Z

Temperature measuring ranges (adjustable)	DIP 1	DIP 2
-35...+75 °C	ON	ON
-35...+35 °C	OFF	OFF
0...+50 °C (default)	OFF	ON
0...+80 °C	ON	OFF

Connection\*:  
2-wire connection for devices with/without display (not illuminated)  
3-wire connection for devices with illuminated display

Connection\*\*:  
3-wire connection for devices with/without display (not illuminated)  
4-wire connection for devices with illuminated display

For the I variant the humidity path must be connected!

Temperature table  
MR: -35...+75 °C

°C	U <sub>A</sub> in V	I <sub>A</sub> in mA
-35	0.0	4.0
-30	0.5	4.7
-25	0.9	5.5
-20	1.4	6.2
-15	1.8	6.9
-10	2.3	7.6
-5	2.7	8.4
0	3.2	9.1
5	3.6	9.8
10	4.1	10.5
15	4.5	11.3
20	5.0	12.0
25	5.5	12.7
30	5.9	13.5
35	6.4	14.2
40	6.8	14.9
45	7.3	15.6
50	7.7	16.4
55	8.2	17.1
60	8.6	17.8
65	9.1	18.5
70	9.5	19.2
75	10.0	20.0

Temperature table  
MR: -35...+35 °C

°C	U <sub>A</sub> in V	I <sub>A</sub> in mA
-35	0.0	4.0
-30	0.7	5.1
-25	1.4	6.3
-20	2.1	7.4
-15	2.9	8.6
-10	3.6	9.7
-5	4.3	10.9
0	5.0	12.0
5	5.7	13.1
10	6.4	14.3
15	7.1	15.4
20	7.9	16.6
25	8.6	17.7
30	9.3	18.9
35	10.0	20.0

Temperature table  
MR: 0...+50 °C

°C	U <sub>A</sub> in V	I <sub>A</sub> in mA
0	0.0	4.0
5	1.0	5.6
10	2.0	7.2
15	3.0	8.8
20	4.0	10.4
25	5.0	12.0
30	6.0	13.6
35	7.0	15.2
40	8.0	16.8
45	9.0	18.4
50	10.0	20.0

Temperature table  
MR: 0...+80 °C

°C	U <sub>A</sub> in V	I <sub>A</sub> in mA
0	0.0	4.0
5	0.6	5.0
10	1.3	6.0
15	1.9	7.0
20	2.5	8.0
25	3.1	9.0
30	3.8	10.0
35	4.4	11.0
40	5.0	12.0
45	5.6	13.0
50	6.3	14.0
55	6.9	15.0
60	7.5	16.0
65	8.1	17.0
70	8.8	18.0
75	9.4	19.0
80	10.0	20.0

Humidity table  
MR: 0...100% r. H.

% r.H.	U <sub>A</sub> in V	I <sub>A</sub> in mA
0	0.0	4.0
5	0.5	4.8
10	1.0	5.6
15	1.5	6.4
20	2.0	7.2
25	2.5	8.0
30	3.0	8.8
35	3.5	9.6
40	4.0	10.4
45	4.5	11.2
50	5.0	12.0
55	5.5	12.8
60	6.0	13.6
65	6.5	14.4
70	7.0	15.2
75	7.5	16.0
80	8.0	16.8
85	8.5	17.6
90	9.0	18.4
95	9.5	19.2
100	10.0	20.0

On-wall humidity and temperature sensors ( $\pm 2.0\%$ ),  
calibratable, with multi-range switching  
and active/passive output

AFF / AFTF ( $\pm 2.0\%$ )  
with cable gland



**WS-03**  
Weather and sun  
protection hood

**HYGRASGARD® AFF** On-wall humidity sensors ( $\pm 2.0\%$ ), *Standard*  
**HYGRASGARD® AFTF** On-wall humidity and temperature sensors ( $\pm 2.0\%$ ), *Standard*

Type / WG02	Measuring Range / Readout		Output		Display	Item No.	Price
	Humidity	Temperature	Humidity	Temperature			
<b>AFF</b>							
AFF-I	0...100% r. H.	-	4...20 mA	-		1201-7112-0000-000	181,26 €
AFF-I LCD	0...100% r. H.	-	4...20 mA	-	■	1201-7112-0400-000	229,75 €
AFF-U	0...100% r. H.	-	0-10V	-		1201-7111-0000-000	181,26 €
AFF-U LCD	0...100% r. H.	-	0-10V	-	■	1201-7111-0400-000	229,75 €
<b>AFTF</b>							
AFTF-I	0...100% r. H.	-35...+75 °C -35...+35 °C 0...+50 °C 0...+80 °C	4...20 mA	4...20 mA		1201-7112-1000-000	198,84 €
AFTF-I LCD	0...100% r. H.	(4x as above)	4...20 mA	4...20 mA	■	1201-7112-1400-000	247,33 €
AFTF-U	0...100% r. H.	-35...+75 °C -35...+35 °C 0...+50 °C 0...+80 °C	0-10V	0-10V		1201-7111-1000-000	198,84 €
AFTF-U LCD	0...100% r. H.	(4x as above)	0-10V	0-10V	■	1201-7111-1400-000	247,33 €
<b>Housing variant:</b>	Cable connection <b>with cable gland</b> (M12 connector on request)						

**HYGRASGARD® AFTF-U xx** On-wall humidity and temperature sensors ( $\pm 2.0\%$ ), *Standard*  
(passive temperature sensor)

Type / WG02	Measuring Range / Readout		Output		Item No.	Price
	Humidity	Temperature	Humidity	Temperature		
<b>AFTF-U xx</b>	<b>Pt, Ni, LM235Z, NTC</b>		<b>(active / passive)</b>			
AFTF-U Pt100	0...100% r. H.	-35...+75 °C -35...+35 °C 0...+50 °C 0...+80 °C	0-10V	0-10V + <b>Pt100</b>	1201-7111-2001-000	200,05 €
AFTF-U Pt1000	0...100% r. H.	(4x as above)	0-10V	0-10V + <b>Pt1000</b>	1201-7111-2005-000	201,26 €
AFTF-U Ni1000	0...100% r. H.	(4x as above)	0-10V	0-10V + <b>Ni1000</b>	1201-7111-2009-000	201,87 €
AFTF-U NiTK	0...100% r. H.	(4x as above)	0-10V	0-10V + <b>Ni1000TK5000</b>	1201-7111-2010-000	202,47 €
AFTF-U LM235Z	0...100% r. H.	(4x as above)	0-10V	0-10V + <b>LM235Z</b> , 10mV / K	1201-7111-2021-000	201,38 €
AFTF-U NTC1,8K	0...100% r. H.	(4x as above)	0-10V	0-10V + <b>NTC 1,8 kOhm</b>	1201-7111-2012-000	202,23 €
AFTF-U NTC10K	0...100% r. H.	(4x as above)	0-10V	0-10V + <b>NTC 10 kOhm</b>	1201-7111-2015-000	199,45 €
AFTF-U NTC20K	0...100% r. H.	(4x as above)	0-10V	0-10V + <b>NTC 20 kOhm</b>	1201-7111-2016-000	199,45 €
<b>Housing variant:</b>	Cable connection <b>with cable gland</b> (M12 connector on request)					





S+S REGELTECHNIK

**HYGRASGARD® AFF-25**  
**HYGRASGARD® AFTF-25**

On-wall humidity sensors and temperature sensors ( $\pm 1.8\%$ ),  
calibratable, with multi-range switching  
and active output



AFF-25 / AFTF-25 ( $\pm 1.8\%$ )  
with cable gland

HYGRASGARD® AFF-25		On-wall humidity sensors, <b>pluggable</b> ( $\pm 1.8\%$ ), <i>Deluxe</i>					
HYGRASGARD® AFTF-25		On-wall humidity and temperature sensors, <b>pluggable</b> ( $\pm 1.8\%$ ), <i>Deluxe</i>					
Type / WG02	Measuring Range / Readout		Output		Display	Item No.	Price
	Humidity	Temperature	Humidity	Temperature			
<b>AFF-25</b>							
AFF-25-I	0...100 % r. H.	–	4... 20 mA	–		1201-7132-0000-101	<b>339,47 €</b>
AFF-25-I LCD	0...100 % r. H.	–	4... 20 mA	–	■	1201-7132-0400-101	<b>386,91 €</b>
AFF-25-U	0...100 % r. H.	–	0-10 V	–		1201-7131-0000-101	<b>339,47 €</b>
AFF-25-U LCD	0...100 % r. H.	–	0-10 V	–	■	1201-7131-0400-101	<b>386,91 €</b>
<b>AFTF-25</b>							
AFTF-25-I	0...100 % r. H.	–35...+75 °C –35...+35 °C 0...+50 °C 0...+80 °C	4... 20 mA	4... 20 mA		1201-7132-1000-101	<b>360,08 €</b>
AFTF-25-I LCD	0...100 % r. H.	(4x as above)	4... 20 mA	4... 20 mA	■	1201-7132-1400-101	<b>407,53 €</b>
AFTF-25-U	0...100 % r. H.	–35...+75 °C –35...+35 °C 0...+50 °C 0...+80 °C	0-10 V	0-10 V		1201-7131-1000-101	<b>360,08 €</b>
AFTF-25-U LCD	0...100 % r. H.	(4x as above)	0-10 V	0-10 V	■	1201-7131-1400-101	<b>407,53 €</b>
<b>Housing variant:</b>	Cable connection <b>with cable gland</b> (M12 connector on request)						

ACCESSORIES			
<b>SF-M</b>	Metal sinter filter, $\varnothing$ 16 mm, L=32 mm, exchangeable stainless steel <b>V4A</b> (1.4404)	7000-0050-2200-100	<b>40,31 €</b>
<b>MSK-25</b>	Pluggable <b>measuring head</b> (probe) stainless steel <b>V2A</b> (1.4301), Metal sinter filter, $\varnothing$ 16 mm, L=88.5 mm, exchangeable replacement element for <b>AFF-25/AFTF-25</b>	7201-1131-0000-000	<b>204,90 €</b>
<b>WS-01</b>	Sun and ball-impact protection hood, 184 x 180 x 80 mm, stainless steel <b>V2A</b> (1.4301)	7100-0040-2000-000	<b>30,26 €</b>
<b>WS-03</b>	Weather and sun protection hood, 200 x 180 x 150 mm, stainless steel <b>V2A</b> (1.4301)	7100-0040-6000-000	<b>42,61 €</b>

For further information see last chapter!

On-wall humidity sensors and temperature sensors ( $\pm 1.8\%$ ),  
calibratable, with multi-range switching  
and active output

AFTF-20-Q ( $\pm 1.8\%$ )  
with M12 connector



**HYGRASGARD®** On-wall humidity sensors and temperature sensors ( $\pm 1.8\%$ ), *Premium*  
**AFTF-20-Q** (with M12 connector)

Type / WG02	Measuring Range / Readout		Output		Display	Item No.	Price
	Humidity	Temperature	Humidity	Temperature	● = Q		
<b>AFTF-20-Q</b>							
AFTF-20-I Q	0...100% r. H.	-35...+75 °C -35...+35 °C 0...+50 °C 0...+80 °C	4...20 mA	4...20 mA	●	2003-6121-2100-001	292,15 €
AFTF-20-I Q LCD	0...100% r. H.	(4x as above)	4...20 mA	4...20 mA	● ■	2003-6122-2100-001	338,22 €
AFTF-20-U Q	0...100% r. H.	-35...+75 °C -35...+35 °C 0...+50 °C 0...+80 °C	0-10V	0-10V	●	2003-6121-1100-001	292,15 €
AFTF-20-U Q LCD	0...100% r. H.	(4x as above)	0-10V	0-10V	● ■	2003-6122-1100-001	338,22 €
<b>Housing variant "Q":</b>		Cable connection with M12 connector (male, 5-pin, A-code)					

**ACCESSORIES**

<b>SF-M</b>	Metal sinter filter, $\varnothing$ 16 mm, L = 32 mm, exchangeable stainless steel V4A (1.4404)	7000-0050-2200-100	40,31 €
-------------	--	--------------------	---------

For further information see last chapter!



S+S REGELTECHNIK

HYGRASGARD® AFF-20  
HYGRASGARD® AFTF-20

On-wall humidity sensors and temperature sensors ( $\pm 1.8\%$ ),  
calibratable, with multi-range switching  
and active output



AFF-20 / AFTF-20 ( $\pm 1.8\%$ )  
with cable gland

HYGRASGARD® AFF-20		On-wall humidity sensors ( $\pm 1.8\%$ ), <i>Premium</i> (with cable gland)					
Type / WG02	Measuring Range / Readout Humidity	Readout Temperature	Output Humidity	Temperature	Display	Item No.	Price
<b>AFF-20</b>							
AFF-20-I	0...100% r. H.	–	4... 20 mA	–		1201-7112-0000-201	<b>229,75 €</b>
AFF-20-I LCD	0...100% r. H.	–	4... 20 mA	–	■	1201-7112-0400-201	<b>278,25 €</b>
AFF-20-U	0...100% r. H.	–	0-10 V	–		1201-7111-0000-201	<b>229,75 €</b>
AFF-20-U LCD	0...100% r. H.	–	0-10 V	–	■	1201-7111-0400-201	<b>278,25 €</b>
<b>Housing variant:</b>	Cable connection <b>with cable gland</b> (M12 connector on request)						

HYGRASGARD® AFTF-20		On-wall humidity and temperature sensors ( $\pm 1.8\%$ ), <i>Premium</i> (with cable gland)					
Type / WG02	Measuring Range / Readout Humidity	Readout Temperature	Output Humidity	Temperature	Display	Item No.	Price
<b>AFTF-20</b>							
AFTF-20-I	0...100% r. H.	–35...+75 °C –35...+35 °C 0...+50 °C 0...+80 °C	4... 20 mA	4... 20 mA		1201-7112-1000-201	<b>252,22 €</b>
AFTF-20-I LCD	0...100% r. H.	(4x as above)	4... 20 mA	4... 20 mA	■	1201-7112-1400-201	<b>298,30 €</b>
AFTF-20-U	0...100% r. H.	–35...+75 °C –35...+35 °C 0...+50 °C 0...+80 °C	0-10 V	0-10 V		1201-7111-1000-201	<b>252,22 €</b>
AFTF-20-U LCD	0...100% r. H.	(4x as above)	0-10 V	0-10 V	■	1201-7111-1400-201	<b>298,30 €</b>
<b>Housing variant:</b>	Cable connection <b>with cable gland</b> (M12 connector see <b>AFTF-20-Q</b> )						

ACCESSORIES								
<b>SF-M</b>	<b>Metal</b> sinter filter, $\varnothing$ 16 mm, L=32 mm, exchangeable stainless steel <b>V4A</b> (1.4404)						7000-0050-2200-100	<b>40,31 €</b>
For further information see last chapter!								

**On-wall humidity sensors and temperature sensors (± 1.8 %),  
calibratable, with multi-range switching  
and active output**

Calibratable outdoor humidity and temperature sensor **HYGRASGARD® AFTF-20-VA** (± 1.8 %) with metal sinter filter, rugged housing, **stainless steel V4A**, optionally with /without display, with cable gland or M12 connector according to DIN EN 61076-2-101.

It measures the relative humidity and the temperature of the air and converts the measurand into a standard signal of 0 - 10 V or 4...20 mA. It has four switchable temperature ranges and is applied in non-aggressive dust-free atmospheres in refrigeration, air conditioning, ventilation and clean room technology. These measuring transducers are designed for exact detection of humidity. A digital long-term stable sensor is used as measuring element for humidity measurement. The sensor is factory-calibrated; an environmental precision adjustment by an expert is possible.

**AFTF-20-VA**  
with cable gland



**AFTF-20-VAQ**  
with M12 connector



**TECHNICAL DATA**

Power supply:	24 V AC (± 20 %); 15...36 V DC for U variant 15...36 V DC for I variant, depending on working resistance, residual ripple stabilised ± 0.3 V
Working resistance:	$R_b \text{ (ohm)} = (U_b - 14 \text{ V}) / 0.02 \text{ A}$ for I variant, see load resistance diagram
Load resistance:	$R_L > 5 \text{ kOhm}$ for U variant
Power consumption:	< 1.1 VA / 24 V DC; < 2.2 VA / 24 V AC
Sensors:	<b>digital humidity sensor with integrated temperature sensor</b> , low hysteresis, high long-term stability

**HUMIDITY**

Measuring range, humidity:	0...100 % r. H.
Permitted humidity:	< 95 % r. H., non-precipitating air
Deviation in humidity:	typically <b>± 1.8 %</b> (10...90 % r. H.) at +25 °C, otherwise ± 2.0 %
Output humidity:	0 - 10 V for U variant 4...20 mA for I variant

**TEMPERATURE**

Measuring range, temperature:	<b>multi-range switching</b> (see table) <b>-35...+35 °C; -35...+75 °C; 0...+50 °C; 0...+80 °C</b>
Ambient temperature:	storage -35...+85 °C; operation -30...+80 °C, non-precipitating
Deviation, temperature:	typically ± 0.2 K at +25 °C
Output, temperature:	0 - 10 V for U variant 4...20 mA for I variant
Electrical connection:	2-, 3-, or 4-wire connection (see connecting diagram), 0.14 - 1.5 mm <sup>2</sup> , via terminal screws
Cable connection:	<b>cable gland, stainless steel V2A</b> (1.4305) (M20 x 1.5; with strain relief, exchangeable, inner diameter 6 - 12 mm) or <b>M12 connector</b> (male, 5-pin, A-code) according to DIN EN 61076-2-101
Housing:	<b>stainless steel V4A</b> (1.4571), with non-distortion cover bolting, impact resistant, high EMI shielding, corrosion, temperature, weather- and UV-resistant
Housing dimensions:	143 x 97 x 61 mm (Tyr 2E)
Protective tube:	made from stainless steel V2A (1.4301), Ø 16 mm, NL = 137 mm
Sensor protection:	<b>metal sinter filter</b> , Ø 16 mm, L = 32 mm, exchangeable, stainless steel V4A (1.4404)
Process connection:	by screws via the mounting fixture on the housing
Long-term stability:	± 1 % per year
Protection class:	III (according to EN 60 730)
Protection type:	<b>IP 65</b> (according to EN 60 529) Housing tested, TÜV SÜD, Report No. 713160960B (Skadi2)
Standards:	CE conformity according to EMC Directive 2014 / 30 / EU, according to EN 61326-1, according to EN 61326-2-3
Optional:	<b>display with illumination</b> , three-line, cutout approx. 70 x 40 mm (W x H), to display the ACTUAL temperature and ACTUAL humidity

**ACCESSORIES** (see table)



On-wall humidity sensors and temperature sensors ( $\pm 1.8\%$ ),  
calibratable, with multi-range switching  
and active output

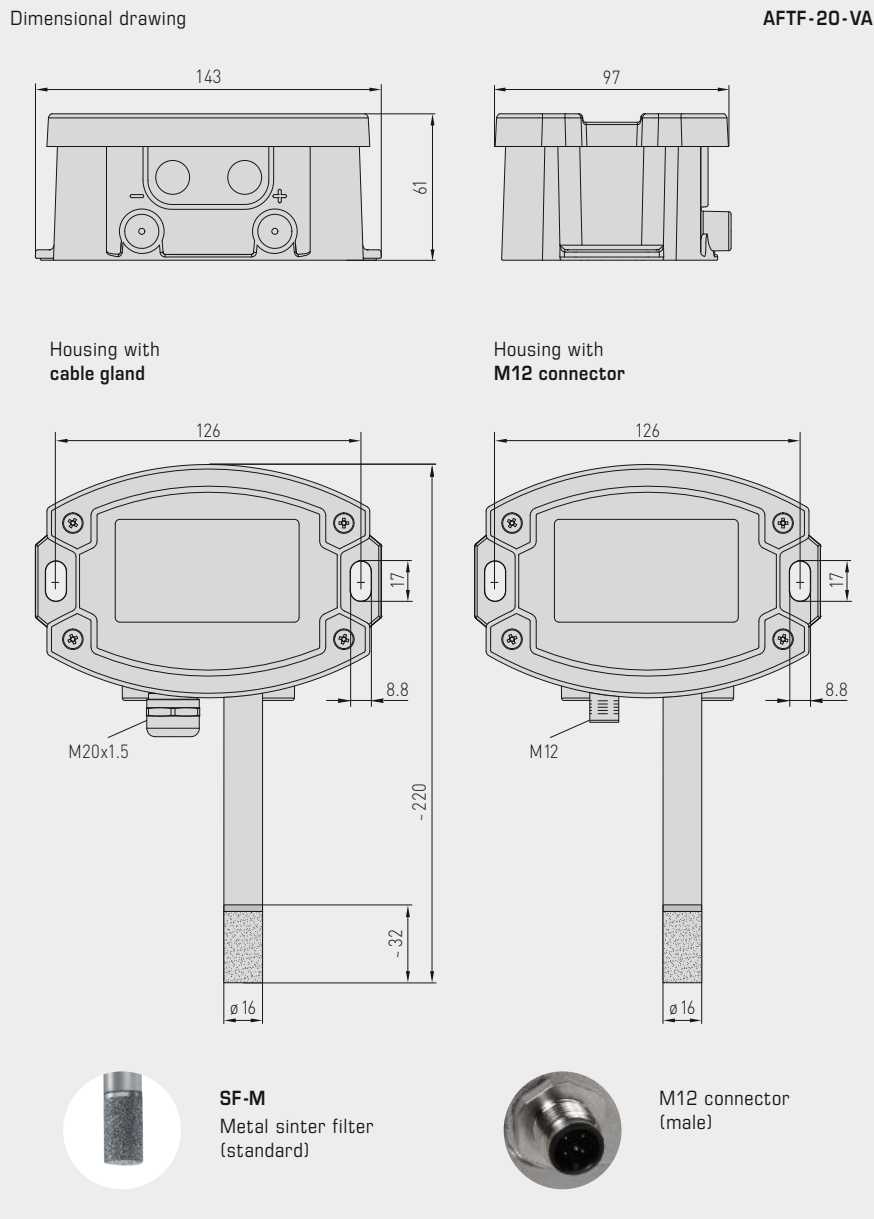

AFTF-20-VA  
with cable gland  
and display



AFTF-20-VAQ  
with M12 connector  
and display





On-wall humidity sensors and temperature sensors (± 1.8%),  
calibratable, with multi-range switching  
and active output

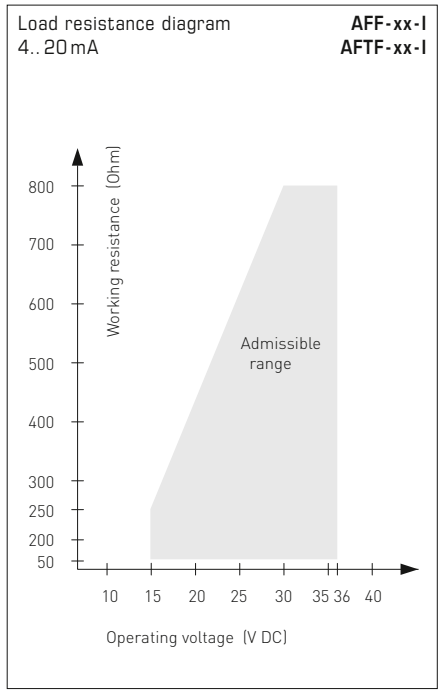
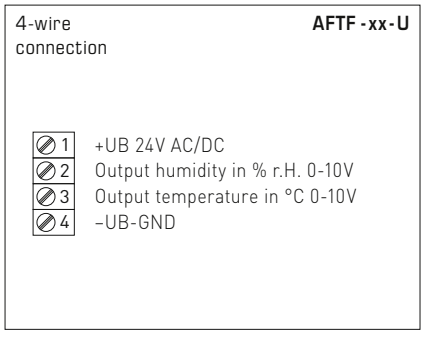
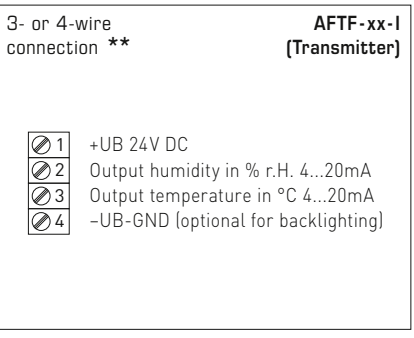
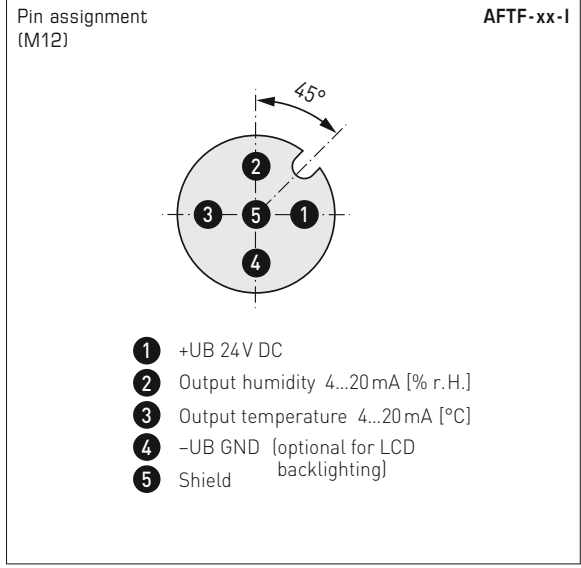
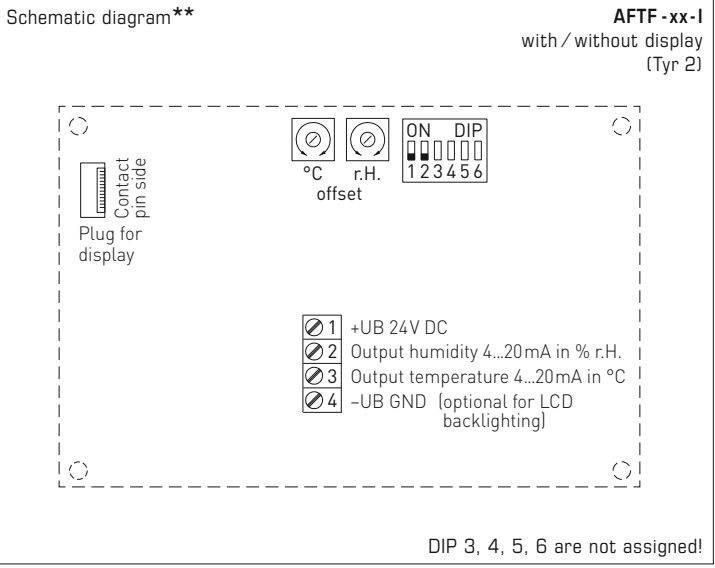
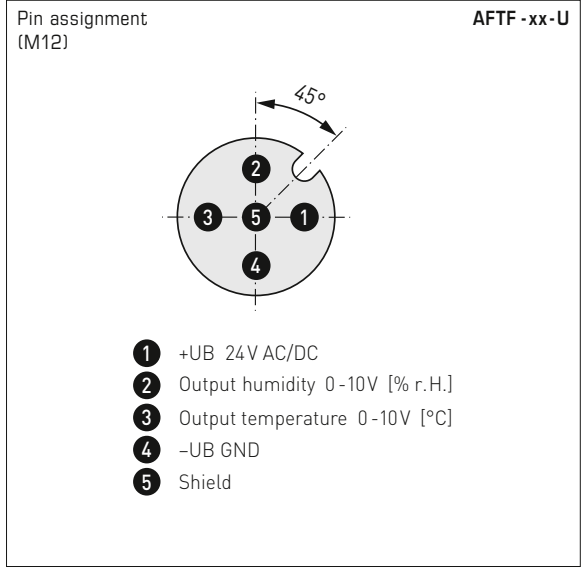
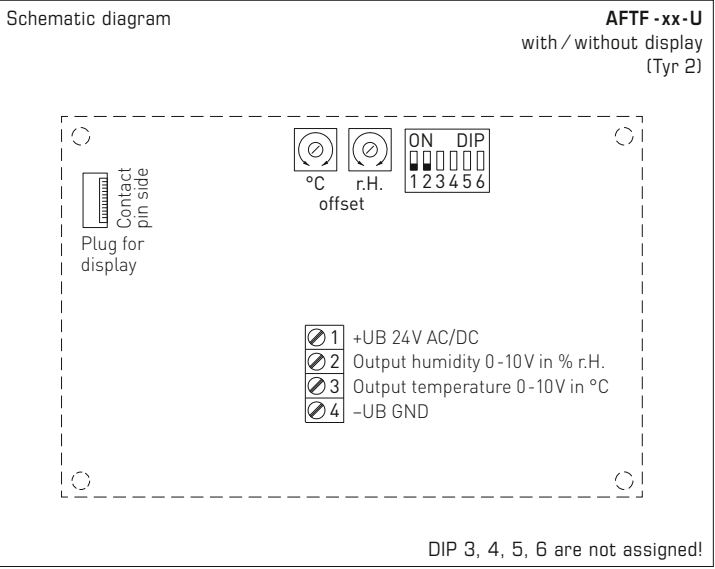

Connection\*\*:  
3-wire connection for devices with/without display (not illuminated)  
4-wire connection for devices with illuminated display

For the **I** variant the humidity path must be connected!

Temperature measuring ranges (adjustable)	DIP 1	DIP 2
-35...+75 °C	ON	ON
-35...+35 °C	OFF	OFF
<b>0...+50 °C (default)</b>	OFF	ON
0...+80 °C	ON	OFF



On-wall humidity sensors and temperature sensors (± 1.8%),  
calibratable, with multi-range switching  
and active output

AFTF-20-VAQ  
with display,  
hinged



Temperature table  
MR: -35...+75 °C

°C	U <sub>A</sub> in V	I <sub>A</sub> in mA
-35	0.0	4.0
-30	0.5	4.7
-25	0.9	5.5
-20	1.4	6.2
-15	1.8	6.9
-10	2.3	7.6
-5	2.7	8.4
0	3.2	9.1
5	3.6	9.8
10	4.1	10.5
15	4.5	11.3
20	5.0	12.0
25	5.5	12.7
30	5.9	13.5
35	6.4	14.2
40	6.8	14.9
45	7.3	15.6
50	7.7	16.4
55	8.2	17.1
60	8.6	17.8
65	9.1	18.5
70	9.5	19.2
75	10.0	20.0

Temperature table  
MR: -35...+35 °C

°C	U <sub>A</sub> in V	I <sub>A</sub> in mA
-35	0.0	4.0
-30	0.7	5.1
-25	1.4	6.3
-20	2.1	7.4
-15	2.9	8.6
-10	3.6	9.7
-5	4.3	10.9
0	5.0	12.0
5	5.7	13.1
10	6.4	14.3
15	7.1	15.4
20	7.9	16.6
25	8.6	17.7
30	9.3	18.9
35	10.0	20.0

Temperature table  
MR: 0...+50 °C

°C	U <sub>A</sub> in V	I <sub>A</sub> in mA
0	0.0	4.0
5	1.0	5.6
10	2.0	7.2
15	3.0	8.8
20	4.0	10.4
25	5.0	12.0
30	6.0	13.6
35	7.0	15.2
40	8.0	16.8
45	9.0	18.4
50	10.0	20.0

Temperature table  
MR: 0...+80 °C

°C	U <sub>A</sub> in V	I <sub>A</sub> in mA
0	0.0	4.0
5	0.6	5.0
10	1.3	6.0
15	1.9	7.0
20	2.5	8.0
25	3.1	9.0
30	3.8	10.0
35	4.4	11.0
40	5.0	12.0
45	5.6	13.0
50	6.3	14.0
55	6.9	15.0
60	7.5	16.0
65	8.1	17.0
70	8.8	18.0
75	9.4	19.0
80	10.0	20.0

Humidity table  
MR: 0...100% r. H.

% r.H.	U <sub>A</sub> in V	I <sub>A</sub> in mA
0	0.0	4.0
5	0.5	4.8
10	1.0	5.6
15	1.5	6.4
20	2.0	7.2
25	2.5	8.0
30	3.0	8.8
35	3.5	9.6
40	4.0	10.4
45	4.5	11.2
50	5.0	12.0
55	5.5	12.8
60	6.0	13.6
65	6.5	14.4
70	7.0	15.2
75	7.5	16.0
80	8.0	16.8
85	8.5	17.6
90	9.0	18.4
95	9.5	19.2
100	10.0	20.0

On-wall humidity sensors and temperature sensors ( $\pm 1.8\%$ ),  
calibratable, with multi-range switching  
and active output

AFTF-20-VAQ  
with M12 connector



**HYGRASGARD® AFTF-20-VAQ** On-wall humidity sensors and temperature sensors ( $\pm 1.8\%$ ), *ID*  
(with M12 connector)

Type / WG02I	Measuring Range / Readout		Output		Display	Item No.	Price
	Humidity	Temperature	Humidity	Temperature	● = Q		
<b>AFTF-20-VAQ</b>						<b>[active]</b>	
AFTF-20-I VAQ	0...100% r. H.	-35...+75 °C -35...+35 °C 0...+50 °C 0...+80 °C	4...20 mA	4...20 mA	●	2003-6181-2100-001	<b>630,82 €</b>
AFTF-20-I VAQ LCD	0...100% r. H.	(4x as above)	4...20 mA	4...20 mA	● ■	2003-6182-2100-001	<b>778,82 €</b>
AFTF-20-U VAQ	0...100% r. H.	-35...+75 °C -35...+35 °C 0...+50 °C 0...+80 °C	0-10V	0-10V	●	2003-6181-1100-001	<b>630,82 €</b>
AFTF-20-U VAQ LCD	0...100% r. H.	(4x as above)	0-10V	0-10V	● ■	2003-6182-1100-001	<b>778,82 €</b>
<b>Housing variant "Q":</b>	Cable connection with M12 connector (male, 5-pin, A-code)						

**ACCESSORIES**

<b>SF-M</b>	Metal sinter filter, $\varnothing$ 16 mm, L = 32 mm, exchangeable stainless steel V4A (1.4404)	7000-0050-2200-100	<b>40,31 €</b>
-------------	--	--------------------	----------------

For further information see last chapter!



AFTF-20-VA  
with cable gland

HYGRASGARD® AFTF-20-VA		On-wall humidity sensors and temperature sensors ( $\pm 1.8\%$ ), <i>ID</i> (with cable gland)					
Type / WG02I	Measuring Range / Readout		Output		Display	Item No.	Price
	Humidity	Temperature	Humidity	Temperature			
<b>AFTF-20-VA</b>							
AFTF-20-I VA	0...100% r. H.	-35...+75 °C -35...+35 °C 0...+50 °C 0...+80 °C	4... 20 mA	4... 20 mA		2003-6181-2200-001	<b>594,12 €</b>
AFTF-20-I VA <b>LCD</b>	0...100% r. H.	(4x as above)	4... 20 mA	4... 20 mA	■	2003-6182-2200-001	<b>742,12 €</b>
AFTF-20-U VA	0...100% r. H.	-35...+75 °C -35...+35 °C 0...+50 °C 0...+80 °C	0-10 V	0-10 V		2003-6181-1200-001	<b>594,12 €</b>
AFTF-20-U VA <b>LCD</b>	0...100% r. H.	(4x as above)	0-10 V	0-10 V	■	2003-6182-1200-001	<b>742,12 €</b>
<b>Housing variant:</b>		Cable connection <b>with cable gland</b>					

ACCESSORIES			
<b>SF-M</b>	Metal sinter filter, $\varnothing$ 16 mm, L=32 mm, exchangeable stainless steel <b>V4A</b> (1.4404)	7000-0050-2200-100	<b>40,31 €</b>
For further information see last chapter!			



**On-wall outdoor humidity sensors (± 2.0 %),  
for mixture ratio, relative/absolute humidity,  
dew point, enthalpy (switchable) and temperature,  
with multi-range switching, with active output**

The universal humidity sensors **HYGRASGARD® AAVTF** are used to determine diverse characteristic variables in humidity measurement. The relative humidity and temperature of the ambient air are measured. From these measurands, the different characteristic variables are internally calculated.

For device version x-U, two outputs of 0 - 10 V are available, for Version x-I two outputs of 4...20 mA. Here, the output variables for these outputs can be defined using DIP switches. Selectable for output 1 are relative humidity [% r. H.], absolute humidity [g/m<sup>3</sup>], mixture ratio [g/kg], dew point temperature [°C], or enthalpy [kJ/kg] (while neglecting the atmospheric air pressure). At output 2, four different measuring ranges for ambient temperature [°C] are selectable. Ex-factory condition (default) for output 1 is relative humidity 0...100% r. H., for output 2 temperature measuring range 0...+50°C. Due to the different configuration alternatives provided, numerous measurement and control tasks can be solved by just one device. These devices must be operated in pollutant-free, non-precipitating air, with neither above-atmospheric nor below-atmospheric pressure at the sensors. Application examples include medical technology, refrigeration, air conditioning, and clean room technology. These sensors are suitable for wall mounting.

**TECHNICAL DATA**

Power supply:	24 V AC (± 20 %); 15...36 V DC for U variant 15...36 V DC for I variant, depending on working resistance, residual ripple stabilised ± 0.3 V
Working resistance:	$R_a(\text{ohm}) = (U_b - 14 \text{ V}) / 0.02 \text{ A}$ for I variant
Load resistance:	$R_L > 5 \text{ kOhm}$ for U variant
Power consumption:	< 1 W at 24 V DC; < 2 VA at 24 V AC
Sensors:	<b>digital humidity sensor with integrated temperature sensor,</b> low hysteresis, high long-term stability
Sensor protection:	<b>plastic sinter filter, Ø 16 mm, L = 35 mm, exchangeable</b> (optional <b>metal sinter filter, Ø 16 mm, L = 32 mm</b> )

**HUMIDITY**

Measuring range, humidity:	<b>multi-range switching with 8 switchable measuring ranges</b> (see table) 0...100% r. H. (default)
Operating range, humidity:	10...95% r. H., without formation of dew
Deviation, humidity:	typically <b>± 2.0%</b> (20...80% r. H.) at +25°C, otherwise ± 3.0% Deviations of other outputs result from deviations of humidity and temperature.
Output 1, humidity:	0 - 10 V for U variant (see table) 4...20 mA for I variant (see table)

**TEMPERATURE**

Measuring range, temperature:	<b>multi-range switching with 4 switchable measuring ranges</b> (see table) 0...+50°C (default); -20...+80°C; -35...+75°C; -35...+35°C
Operating range, temperature:	-35...+85°C sensors
Deviation, temperature:	typically ± 0.6 K at +25°C
Output 2, temperature:	0 - 10 V for U variant (see table) 4...20 mA for I variant (see table)
Ambient temperature:	storage -35...+85°C; operation -30...+70°C, non-precipitating
Electrical connection:	4-wire connection for U variant 3-wire connection for I variant (Transmitter) 0.14 - 1.5 mm <sup>2</sup> , via terminal screws
Housing:	plastic, UV-resistant, material polyamide, 30% glass-globe reinforced, with quick-locking screws (slotted/Phillips head combination), colour traffic white (similar to RAL 9016), housing cover for display is transparent!
Housing dimensions:	72 x 64 x 37.8 mm (Tyr 1 without display) 72 x 64 x 43.3 mm (Tyr 1 with display)
Cable connection:	<b>cable gland</b> , plastic (M 16 x 1.5; with strain relief, exchangeable, max. inner diameter 10.4 mm) or <b>M12 connector</b> according to DIN EN 61076-2-101 (optional on request)
Protective tube:	<b>stainless steel V2A</b> (1.4301), Ø = 16 mm, NL = 55 mm
Process connection:	by screws
Protection class:	III (according to EN 60 730)
Protection type:	<b>IP 65</b> (according to EN 60 529) Housing tested, TÜV SÜD, Report No. 713139052 (Tyr 1)
Standards:	CE conformity, electromagnetic compatibility according to EN 61 326, EMC directive 2014 / 30 / EU
Optional:	two-line <b>display with illumination</b> , cutout approx. 36x15 mm (W x H), for displaying actual temperature and actual humidity, as well as the selectable output variables

**ACCESSORIES**

see last chapter

**AAVTF**  
with plastic sinter filter  
(standard)



**SF-M**  
Metal sinter filter  
(optional)







On-wall outdoor humidity sensors ( $\pm 2.0\%$ ), for mixture ratio, relative/absolute humidity, dew point, enthalpy (switchable) and temperature, with multi-range switching, with active output

Dimensional drawing

AAVTF

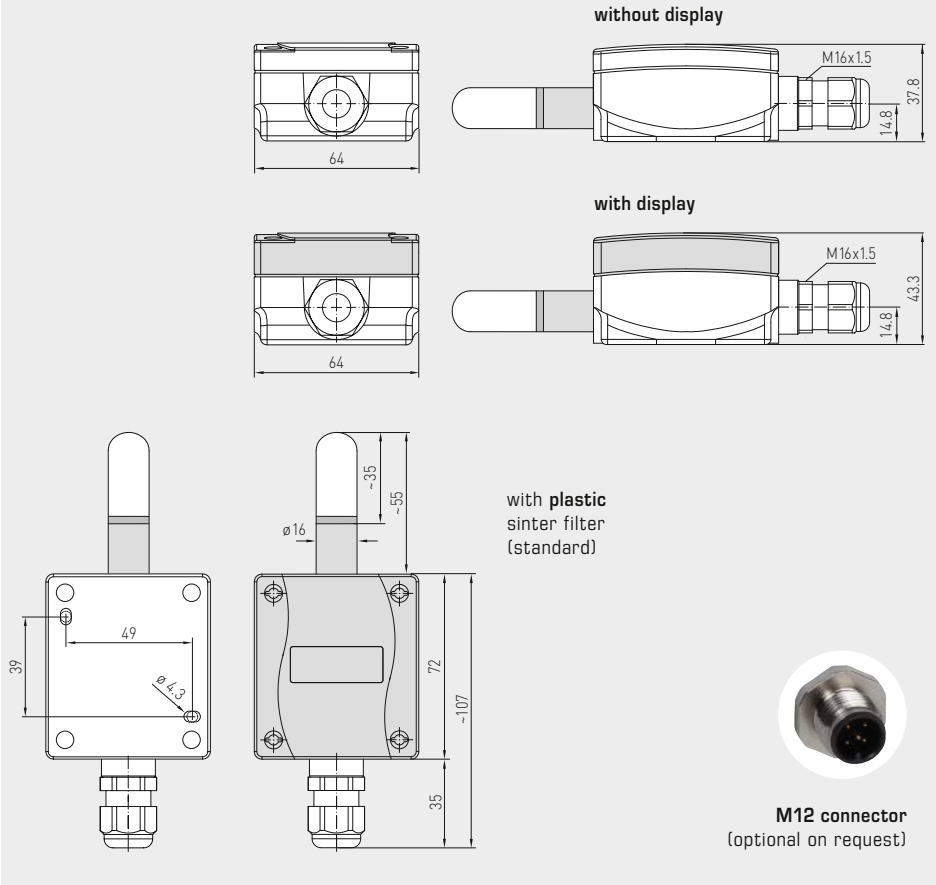

AAVTF with display and plastic sinter filter (standard)



SF-M Metal sinter filter (optional)

M12 connector (optional on request)



Temperature table MR: -35...+75 °C

°C	U <sub>A</sub> in V	I <sub>A</sub> in mA
-35	0.0	4.0
-30	0.5	4.7
-25	0.9	5.5
-20	1.4	6.2
-15	1.8	6.9
-10	2.3	7.6
-5	2.7	8.4
0	3.2	9.1
5	3.6	9.8
10	4.1	10.5
15	4.5	11.3
20	5.0	12.0
25	5.5	12.7
30	5.9	13.5
35	6.4	14.2
40	6.8	14.9
45	7.3	15.6
50	7.7	16.4
55	8.2	17.1
60	8.6	17.8
65	9.1	18.5
70	9.5	19.2
75	10.0	20.0

Temperature table MR: -35...+35 °C

°C	U <sub>A</sub> in V	I <sub>A</sub> in mA
-35	0.0	4.0
-30	0.7	5.1
-25	1.4	6.3
-20	2.1	7.4
-15	2.9	8.6
-10	3.6	9.7
-5	4.3	10.9
0	5.0	12.0
5	5.7	13.1
10	6.4	14.3
15	7.1	15.4
20	7.9	16.6
25	8.6	17.7
30	9.3	18.9
35	10.0	20.0

Temperature table MR: 0...+50 °C

°C	U <sub>A</sub> in V	I <sub>A</sub> in mA
0	0.0	4.0
5	1.0	5.6
10	2.0	7.2
15	3.0	8.8
20	4.0	10.4
25	5.0	12.0
30	6.0	13.6
35	7.0	15.2
40	8.0	16.8
45	9.0	18.4
50	10.0	20.0

Temperature table MR: -20...+80 °C

°C	U <sub>A</sub> in V	I <sub>A</sub> in mA
-20	0.0	4.0
-15	0.5	4.8
-10	1.0	5.6
-5	1.5	6.4
0	2.0	7.2
5	2.5	8.0
10	3.0	8.8
15	3.5	9.6
20	4.0	10.4
25	4.5	11.2
30	5.0	12.0
35	5.5	12.8
40	6.0	13.6
45	6.5	14.4
50	7.0	15.2
55	7.5	16.0
60	8.0	16.8
65	8.5	17.6
70	9.0	18.4
75	9.5	19.2
80	10.0	20.0

Humidity table MR: 0...100% r. H.

% r.H.	U <sub>A</sub> in V	I <sub>A</sub> in mA
0	0.0	4.0
5	0.5	4.8
10	1.0	5.6
15	1.5	6.4
20	2.0	7.2
25	2.5	8.0
30	3.0	8.8
35	3.5	9.6
40	4.0	10.4
45	4.5	11.2
50	5.0	12.0
55	5.5	12.8
60	6.0	13.6
65	6.5	14.4
70	7.0	15.2
75	7.5	16.0
80	8.0	16.8
85	8.5	17.6
90	9.0	18.4
95	9.5	19.2
100	10.0	20.0

On-wall outdoor humidity sensors ( $\pm 2.0\%$ ),  
for mixture ratio, relative/absolute humidity,  
dew point, enthalpy (switchable) and temperature,  
with multi-range switching, with active output

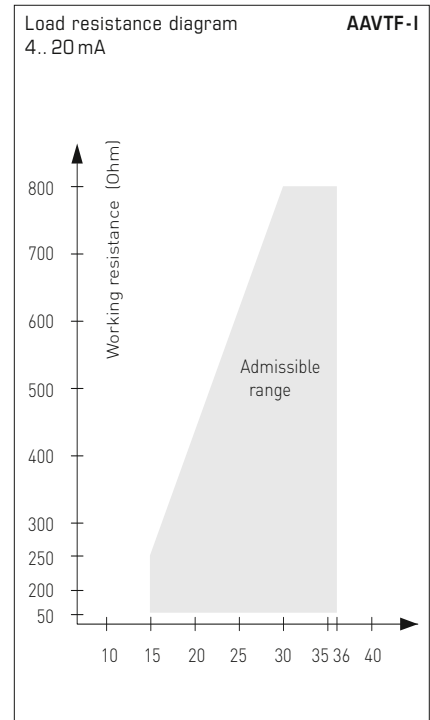
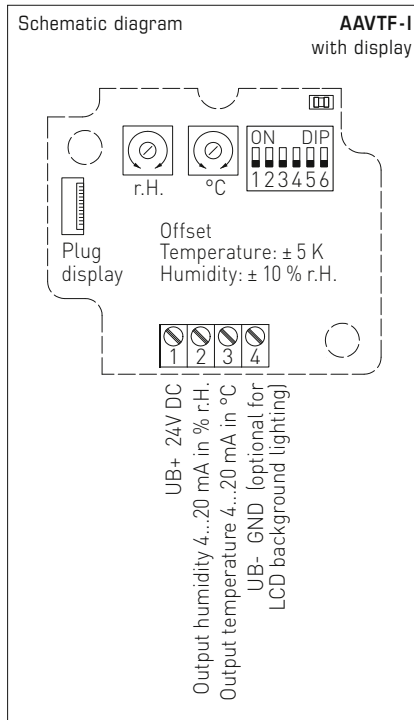
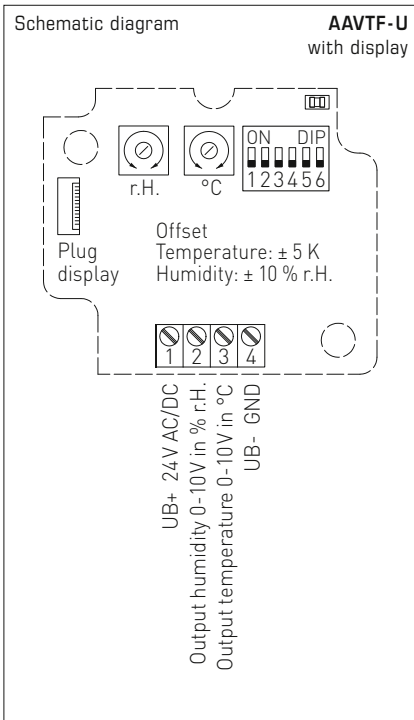

Temperature measuring ranges (adjustable)	DIP 1	DIP 2
0...+50 $^{\circ}\text{C}$ (default)	OFF	OFF
-20...+80 $^{\circ}\text{C}$	ON	OFF
-35...+75 $^{\circ}\text{C}$	OFF	ON
-35...+35 $^{\circ}\text{C}$	ON	ON

Switchable measuring ranges (adjustable)	DIP 3	DIP 4	DIP 5
r.H.: 0...100% (default)	OFF	OFF	OFF
MR: 0...50 g/kg	ON	OFF	OFF
MR: 0...80 g/kg	OFF	ON	OFF
A.H.: 0...50 g/m <sup>3</sup>	OFF	OFF	ON
A.H.: 0...80 g/m <sup>3</sup>	ON	ON	OFF
DP: 0...+50 $^{\circ}\text{C}$	ON	OFF	ON
DP: -20...+80 $^{\circ}\text{C}$	OFF	ON	ON
ENT.: 0...85 kJ/kg	ON	ON	ON

**Possible parameters:**

[r.H.] = relative humidity in %  
 [MR] = mixture ratio in g/kg  
 [A.H.] = absolute humidity in g/m<sup>3</sup>  
 [DP] = dew point in  $^{\circ}\text{C}$   
 [ENT.] = enthalpy in kJ/kg

Service display/output (adjustable)	DIP 6
Display $^{\circ}\text{C}$ and % r.H., output of set measurements via DIP 1-5 (service mode for setting $^{\circ}\text{C}$ and % r.H.)	ON
Display and output of set measurements via DIP 1-5	OFF





On-wall outdoor humidity sensors ( $\pm 2.0\%$ ), for mixture ratio, relative/absolute humidity, dew point, enthalpy (switchable) and temperature, with multi-range switching, with active output

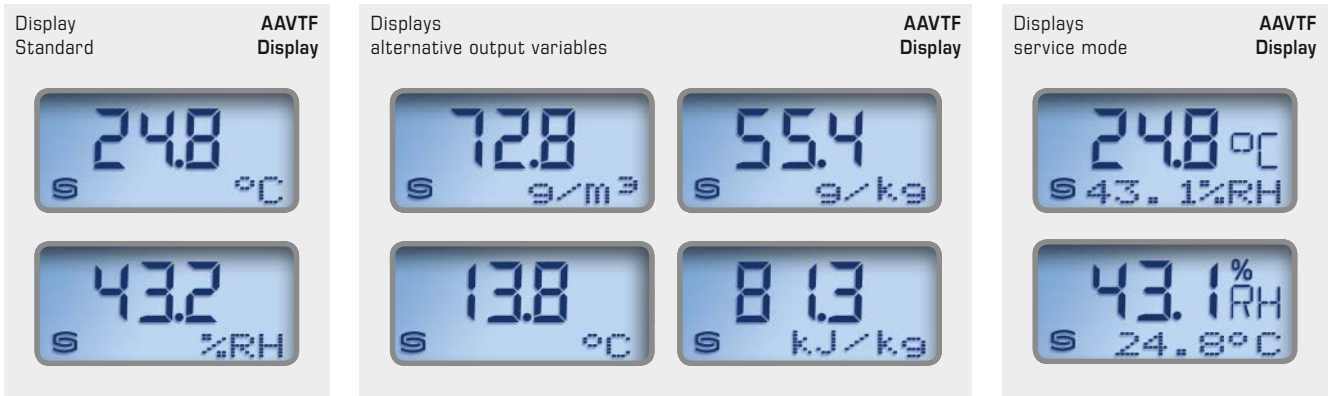

By default, the display alternates between the **actual temperature** and the **actual humidity** (relative humidity). In this case, the first line displays the value while the second line displays the corresponding unit:  
**Temperature in °C**  
**Relative humidity in % r.H.**  
 For improved legibility, backlighting is provided.

**DIP switches** can be used to display an **alternative output variable** instead of the standard display:  
**Absolute humidity in g/m<sup>3</sup>**  
**Dew point in °C**  
**Mixture ratio in g/kg**  
**Enthalpy in kJ/kg**

The **service mode** simultaneously displays (alternately in the first and second lines) the **actual temperature** and the **actual humidity** (relative humidity).

**HYGRASGARD® AAVTF** On-wall outdoor humidity sensors ( $\pm 2.0\%$ )

Type / WG01	Measuring Range Humidity	Temperature	Output Humidity	Temperature	Display	Item No.	Price
<b>AAVTF-I</b>	(switchable)	(switchable)				<b>I-variant</b>	
AAVTF-I	0...100% r. H. (default) 0...50 g/kg (MR) 0...80 g/kg (MR) 0...50 g/m <sup>3</sup> (A.H.) 0...80 g/m <sup>3</sup> (A.H.) 0...+50 °C (DP) -20...+80 °C (DP) 0...85 kJ/kg (ENT.)	0...+50 °C (default) -20...+80 °C -35...+75 °C -35...+35 °C	4...20 mA	4...20 mA		1201-1162-6000-028	<b>195,79 €</b>
<b>AAVTF-I LCD</b>	(8x as above)	(4x as above)	4...20 mA	4...20 mA	■	1201-1162-6200-028	<b>243,26 €</b>
<b>AAVTF-U</b>						<b>U-variant</b>	
AAVTF-U	(8x as above)	(4x as above)	0-10V	0-10V		1201-1161-6000-028	<b>195,79 €</b>
<b>AAVTF-U LCD</b>	(8x as above)	(4x as above)	0-10V	0-10V	■	1201-1161-6200-028	<b>243,26 €</b>
Extra charge:	Other non-standard ranges optional						<b>142,35 €</b>
Optional:	Cable connection with <b>M12 connector</b> according to DIN EN 61076-2-101						on request

**ACCESSORIES**

<b>SF-M</b>	<b>Metal sinter filter</b> , Ø 16 mm, L = 32 mm, exchangeable stainless steel <b>V4A</b> (1.4404)	7000-0050-2200-100	<b>40,31 €</b>
<b>WS-01</b>	<b>Sun and ball-impact protection hood</b> , 184 x 180 x 80 mm, stainless steel <b>V2A</b> (1.4301)	7100-0040-2000-000	<b>30,26 €</b>
<b>WS-04</b>	<b>Weather and sun protection hood</b> , 130 x 180 x 135 mm, stainless steel <b>V2A</b> (1.4301)	7100-0040-7000-000	<b>35,70 €</b>

For further information, see last chapter Accessories!

Duct humidity and temperature sensors ( $\pm 1.8\%$  /  $\pm 2.0\%$ ), including mounting flange, calibratable, with multi-range switching and active/passive output

Calibratable duct humidity-/temperature sensor **HYGRASGARD® KFF-SD/KFTF-SD** ( $\pm 2,0\%$ ), with plastic sinter filter (optional metal sinter filter), housing made from impact-resistant plastic with snap-on lid, with cable gland (optional M12 connector according to DIN EN 61076-2-101).

Calibratable duct humidity-/temperature sensor **HYGRASGARD® KFF/KFTF** ( $\pm 2,0\%$ ) or **KFF-20/KFTF-20** ( $\pm 1,8\%$ ), with plastic sinter filter (optional metal sinter filter), housing made of impact-resistant plastic with quick-locking screws, optionally with/without display, with cable gland (optional M12 connector according to DIN EN 61076-2-101).

It measures the relative humidity and/or the temperature of the air and converts the measurands into a standard signal of 0-10V or 4...20mA. It has four switchable temperature ranges and is applied in non-aggressive dust-free atmospheres in refrigeration, air conditioning, ventilation and clean room technology. These measuring transducers are designed for exact detection of humidity. A digital long-term stable sensor is used as measuring element for humidity measurement. The sensor is factory-calibrated; an environmental precision adjustment by an expert is possible.

### TECHNICAL DATA

Power supply:	24 V AC ( $\pm 20\%$ ); 15...36 V DC for U variant 15...36 V DC for I variant, depending on working resistance, residual ripple stabilised $\pm 0.3V$
Working resistance:	$R_a(\text{ohm}) = (U_b - 14V) / 0.02A$ for I variant, see load resistance diagram
Load resistance:	$R_L > 5k\Omega$ hm for U variant
Power consumption:	$< 1.1VA / 24V DC$ ; $< 2.2VA / 24V AC$
Sensors:	<b>digital humidity sensor with integrated temperature sensor</b> , low hysteresis, high long-term stability

### HUMIDITY

Measuring range, humidity:	0...100% r. H.
Permissible air humidity:	$< 95\%$ r. H., non-precipitating air
Deviation, humidity:	<b>KFF / KFTF / KFF-SD / KFTF-SD:</b> typically $\pm 2.0\%$ (20...80% r. H.) at $+25^\circ C$ , otherwise $\pm 3.0\%$ <b>KFF-20 / KFTF-20:</b> typically $\pm 1.8\%$ (10...90% r. H.) at $+25^\circ C$ , otherwise $\pm 2.0\%$
Output, humidity:	0-10 V for U variant; 4...20 mA for I variant

### TEMPERATURE

Measuring range, temperature:	<b>multi-range switching with 4 switchable measuring ranges</b> (see table) $-35...+35^\circ C$ ; $-35...+75^\circ C$ ; $0...+50^\circ C$ ; $0...+80^\circ C$
Ambient temperature:	storage $-35...+85^\circ C$ ; operation $-30...+75^\circ C$ , non-precipitating
Deviation, temperature:	typically $\pm 0.2K$ at $+25^\circ C$
Output, temperature:	0-10 V for U variant; 4...20 mA for I variant; <b>KFTF-Uxx</b> (passive temperature sensor) see table
Electrical connection:	2-, 3-, or 4-wire connection (see connecting diagram), 0.14 - 1.5 mm <sup>2</sup> , via terminal screws
Cable connection:	<b>cable gland</b> , plastic (M 16 x 1.5; with strain relief, exchangeable, max. inner diameter 10.4 mm) or <b>M12 connector</b> according to DIN EN 61076-2-101 (optional)
Housing:	plastic, UV-resistant, material polyamide, 30% glass-globe reinforced, with quick-locking screws (slotted / Phillips head combination), colour traffic white (similar to RAL 9016), housing cover for display is transparent!
Housing dimensions:	<b>KFF-xx / KFTF-xx</b> (without display): 72 x 64 x 37.8 mm (Tyr 1/01) <b>KFF / KFTF</b> (with display): 72 x 64 x 43.3 mm (Tyr 1) <b>KFF-20 / KFTF-20</b> (with display): 26 x 90 x 50 mm (Tyr 2)
Protective tube:	<b>PLEUROFORM™</b> , material polyamide (PA6), with torsion protection $\varnothing 20$ mm, NL = 235 mm, $v_{max} = 30$ m/s (air) (on request, optional <b>stainless steel V2A</b> (1.4301), $\varnothing 16$ mm)
Sensor protection:	<b>plastic sinter filter</b> , $\varnothing 16$ mm, L = 35 mm, exchangeable (optional <b>metal sinter filter</b> , $\varnothing 16$ mm, L = 32 mm)
Process connection:	by mounting flange, plastic (included in the scope of delivery)
Long-term stability:	$\pm 1\%$ per year
Protection class:	III (according to EN 60 730)
Protection type:	<b>KFF-SD / KFTF-SD</b> <b>IP 54</b> (according to EN 60 529) Housing tested, TÜV SÜD, Report No. 713160960A (Tyr 01) <b>KFF-xx / KFTF-xx</b> <b>IP 65</b> (according to EN 60 529) Housing tested, TÜV SÜD, Report No. 713139052 (Tyr 1)
Standards:	CE conformity, according to EMC directive 2014 / 30 / EU, according to EN 61326-1, according to EN 61326-2-3
Optional:	<b>display with illumination</b> , for displaying ACTUAL temperature and / or ACTUAL humidity <b>KFF / KFTF</b> (Tyr 1): two-line, cutout approx. 36x15 mm (W x H) <b>KFF-20 / KFTF-20</b> (Tyr 2): three-line, cutout approx. 70x40 mm (W x H)

### ACCESSORIES

see last chapter

**SF-K**  
Plastic sinter filter (standard)



**SF-M**  
Metal sinter filter (optional)



**Protective tube stainless steel** (optional on request)

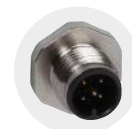

**M12 connector** (optional)

**MFT-20-K**  
Mounting flange, plastic



Dimensional drawing **MFT-20-K**

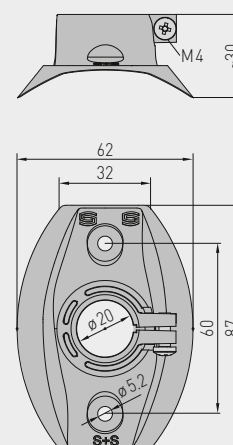



Duct humidity and temperature sensors ( $\pm 1.8\%$  /  $\pm 2.0\%$ ), including mounting flange, calibratable, with multi-range switching and active/passive output



Dimensional drawing

without display

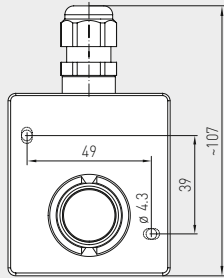
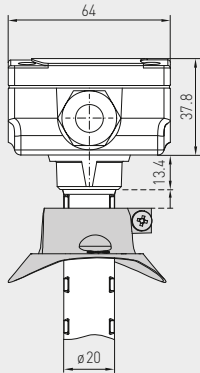

with display

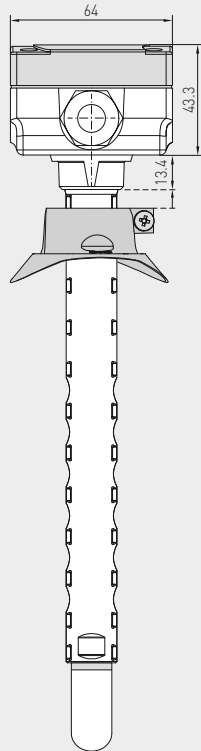

KFF/KFTF with/without display  
KFF-SD/KFTF-SD without display  
KFF-20/KFTF-20 without display

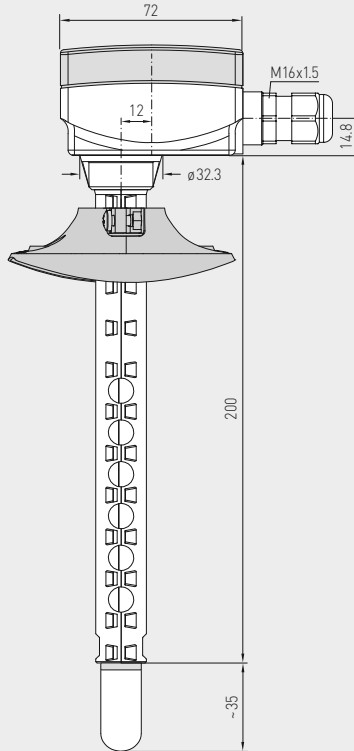

KFF-SD/KFTF-SD ( $\pm 2,0\%$ )  
with snap-on lid  
(IP54)



KFF/KFTF ( $\pm 2,0\%$ )  
KFF-20/KFTF-20 ( $\pm 1,8\%$ )  
without display  
(IP65)

Dimensional drawing

KFF-20/KFTF-20 with display

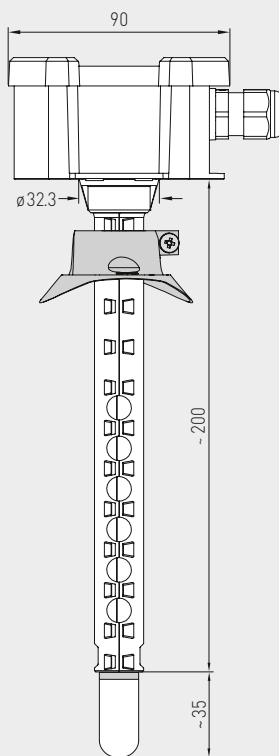
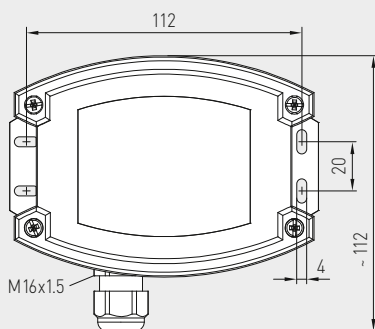
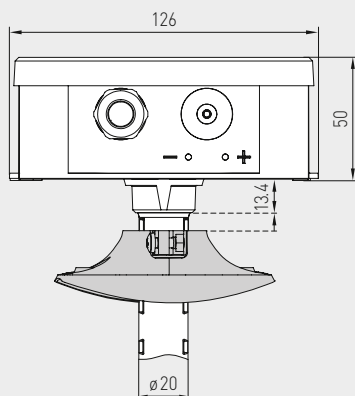

KFF/KFTF ( $\pm 2,0\%$ )  
with display  
(IP65)



KFF-20/KFTF-20 ( $\pm 1,8\%$ )  
with display  
(IP65)



Duct humidity and temperature sensors ( $\pm 1.8\%$  /  $\pm 2.0\%$ ), including mounting flange, calibratable, with multi-range switching and active/passive output

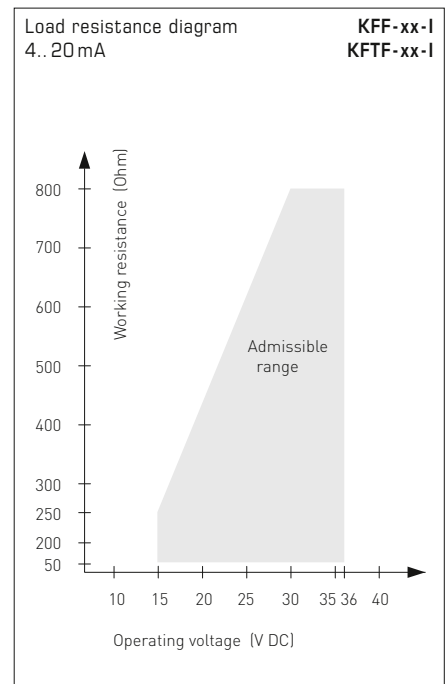
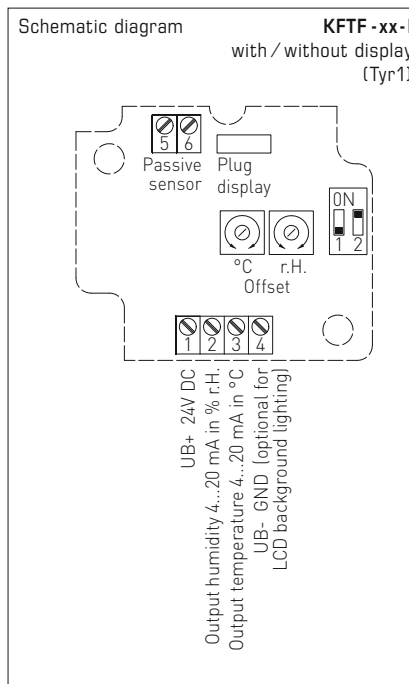
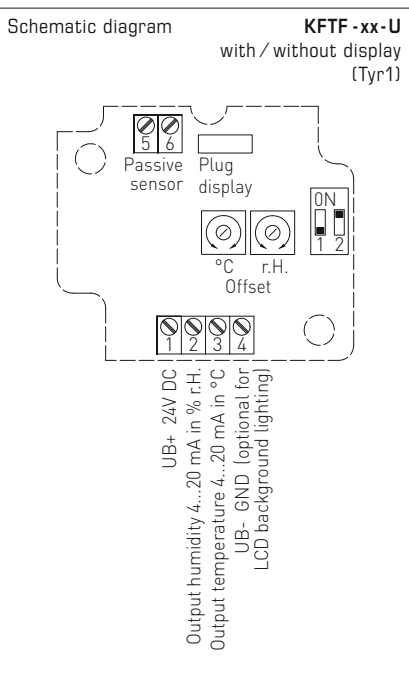
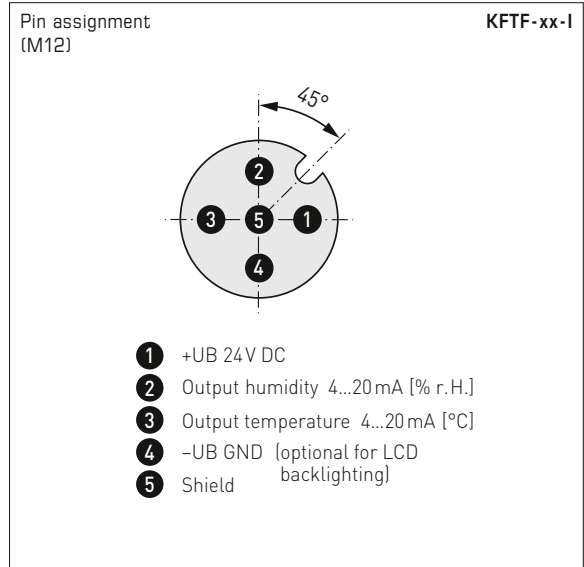
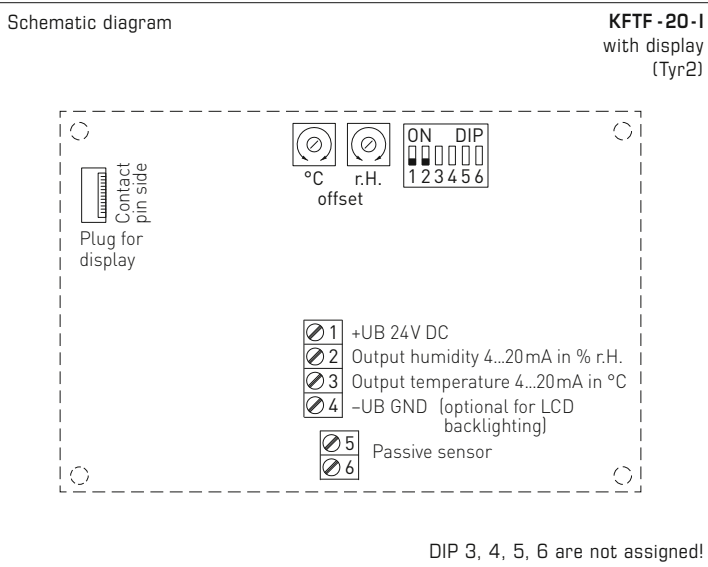
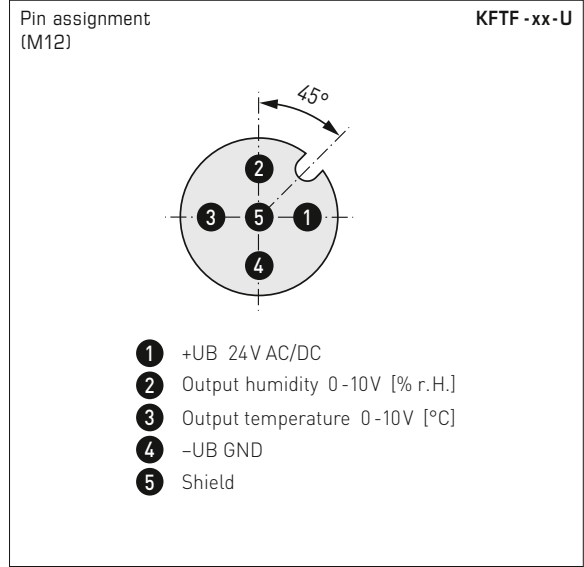
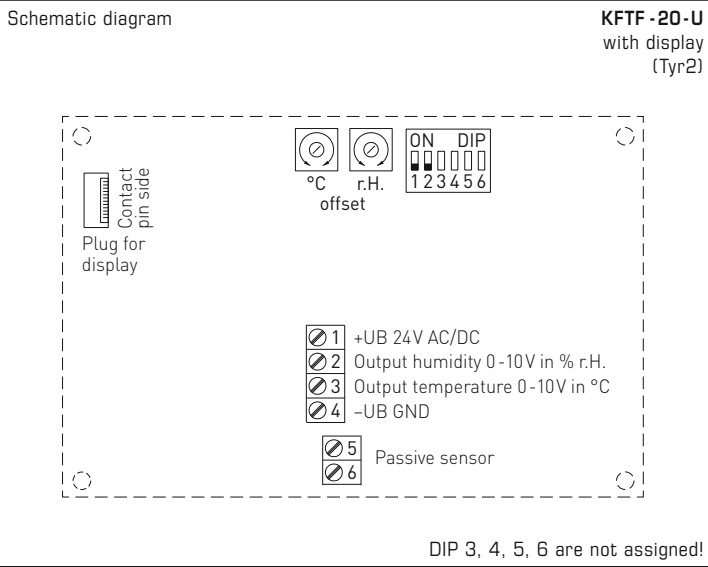



Duct humidity and temperature sensors ( $\pm 1.8\%$  /  $\pm 2.0\%$ ),  
including mounting flange, calibratable, with multi-range switching  
and active/passive output

**3-wire connection** **KFF-xx-U**

- 1 +UB 24V AC/DC
- 2 Output humidity in % r.H. 0-10V
- 3 Free
- 4 -UB-GND

**2- or 3-wire connection \*** **KFF-xx-I (Transmitter)**

- 1 +UB 24V DC
- 2 Output humidity in % r.H. 4...20mA
- 3 Free
- 4 -UB-GND (optional for backlighting)

**4- or 6-wire connection** **KFTF-U (passive temperature sensor)**

- 1 +UB 24V AC/DC
- 2 Output humidity in % r.H. 0-10V
- 3 Output temperature in °C 0-10V
- 4 -UB-GND
- 5 Passive element e.g. Pt1000, Ni1000, LMZ235Z
- 6

**4-wire connection** **KFTF-xx-U**

- 1 +UB 24V AC/DC
- 2 Output humidity in % r.H. 0-10V
- 3 Output temperature in °C 0-10V
- 4 -UB-GND

**3- or 4-wire connection \*\*** **KFTF-xx-I (Transmitter)**

- 1 +UB 24V DC
- 2 Output humidity in % r.H. 4...20mA
- 3 Output temperature in °C 4...20mA
- 4 -UB-GND (optional for backlighting)

**4- or 6-wire connection** **KFTF-I (passive temperature sensor)**

- 1 +UB 24V DC
- 2 Output humidity in % r.H. 4...20mA
- 3 Output temperature in °C 4...20mA
- 4 -UB-GND (optional for backlighting)
- 5 Passive element e.g. Pt1000, Ni1000, LMZ235Z
- 6

Temperature measuring ranges (adjustable)	DIP 1	DIP 2
-35...+75 °C	ON	ON
-35...+35 °C	OFF	OFF
0...+50 °C (default)	OFF	ON
0...+80 °C	ON	OFF

Connection\*:  
2-wire connection for devices with/without display (not illuminated)  
3-wire connection for devices with illuminated display

Connection\*\*:  
3-wire connection for devices with/without display (not illuminated)  
4-wire connection for devices with illuminated display

For the I variant the humidity path must be connected!

Temperature table  
MR: -35...+75 °C

°C	U <sub>A</sub> in V	I <sub>A</sub> in mA
-35	0.0	4.0
-30	0.5	4.7
-25	0.9	5.5
-20	1.4	6.2
-15	1.8	6.9
-10	2.3	7.6
-5	2.7	8.4
0	3.2	9.1
5	3.6	9.8
10	4.1	10.5
15	4.5	11.3
20	5.0	12.0
25	5.5	12.7
30	5.9	13.5
35	6.4	14.2
40	6.8	14.9
45	7.3	15.6
50	7.7	16.4
55	8.2	17.1
60	8.6	17.8
65	9.1	18.5
70	9.5	19.2
75	10.0	20.0

Temperature table  
MR: -35...+35 °C

°C	U <sub>A</sub> in V	I <sub>A</sub> in mA
-35	0.0	4.0
-30	0.7	5.1
-25	1.4	6.3
-20	2.1	7.4
-15	2.9	8.6
-10	3.6	9.7
-5	4.3	10.9
0	5.0	12.0
5	5.7	13.1
10	6.4	14.3
15	7.1	15.4
20	7.9	16.6
25	8.6	17.7
30	9.3	18.9
35	10.0	20.0

Temperature table  
MR: 0...+50 °C

°C	U <sub>A</sub> in V	I <sub>A</sub> in mA
0	0.0	4.0
5	1.0	5.6
10	2.0	7.2
15	3.0	8.8
20	4.0	10.4
25	5.0	12.0
30	6.0	13.6
35	7.0	15.2
40	8.0	16.8
45	9.0	18.4
50	10.0	20.0

Temperature table  
MR: 0...+80 °C

°C	U <sub>A</sub> in V	I <sub>A</sub> in mA
0	0.0	4.0
5	0.6	5.0
10	1.3	6.0
15	1.9	7.0
20	2.5	8.0
25	3.1	9.0
30	3.8	10.0
35	4.4	11.0
40	5.0	12.0
45	5.6	13.0
50	6.3	14.0
55	6.9	15.0
60	7.5	16.0
65	8.1	17.0
70	8.8	18.0
75	9.4	19.0
80	10.0	20.0

Humidity table  
MR: 0...100% r.H.

% r.H.	U <sub>A</sub> in V	I <sub>A</sub> in mA
0	0.0	4.0
5	0.5	4.8
10	1.0	5.6
15	1.5	6.4
20	2.0	7.2
25	2.5	8.0
30	3.0	8.8
35	3.5	9.6
40	4.0	10.4
45	4.5	11.2
50	5.0	12.0
55	5.5	12.8
60	6.0	13.6
65	6.5	14.4
70	7.0	15.2
75	7.5	16.0
80	8.0	16.8
85	8.5	17.6
90	9.0	18.4
95	9.5	19.2
100	10.0	20.0

Duct humidity and temperature sensors ( $\pm 2.0\%$ ), including mounting flange, calibratable, with multi-range switching and active output

KFF-SD / KFTF-SD  
with snap-on lid  
(IP 54)



HYGRASGARD® KFF-SD Duct humidity sensors ( $\pm 2.0\%$ ), *Standard*  
HYGRASGARD® KFTF-SD Duct humidity and temperature sensors ( $\pm 2.0\%$ ), *Standard*

Type / WG01B	Measuring Range / Readout		Output		Item No.	Price
	Humidity	Temperature	Humidity	Temperature		
<b>KFF-SD</b>					<b>IP 54</b>	
KFF-SD-I	0...100% r. H.	–	4...20 mA	–	1201-3182-0000-029	<b>154,58 €</b>
KFF-SD-U	0...100% r. H.	–	0-10 V	–	1201-3181-0000-029	<b>154,58 €</b>
<b>KFTF-SD</b>					<b>IP 54</b>	
KFTF-SD-I	0...100% r. H.	–35...+75 °C –35...+35 °C 0...+50 °C 0...+80 °C	4...20 mA	4...20 mA	1201-3182-1000-029	<b>158,82 €</b>
KFTF-SD-U	0...100% r. H.	(4x as above)	0-10 V	0-10 V	1201-3181-1000-029	<b>158,82 €</b>
<b>Housing variant:</b>	Cable connection <b>with cable gland</b> (M12 connector on request)					

**ACCESSORIES**

<b>SF-M</b>	<b>Metal sinter filter</b> , $\varnothing$ 16 mm, L = 32 mm, exchangeable stainless steel <b>V4A</b> (1.4404)	7000-0050-2200-100	<b>40,31 €</b>
-------------	---	--------------------	----------------

For further information, see chapter Accessories!



KFF / KFTF  
with quick-locking screws  
(IP65)



HYGRASGARD® KFF		Duct humidity sensors ( $\pm 2.0\%$ ), <i>Standard</i>				
HYGRASGARD® KFTF		Duct humidity and temperature sensors ( $\pm 2.0\%$ ), <i>Standard</i>				
Type / WG01	Measuring Range / Readout	Output	Display	Item No.	Price	
	Humidity	Humidity				
	Temperature	Temperature				
<b>KFF</b>				<b>IP65</b>		
KFF-I	0...100 % r. H.	–	4...20 mA	–	1201-3112-0000-029 <b>166,10 €</b>	
KFF-I LCD	0...100 % r. H.	–	4...20 mA	–	■ 1201-3112-0200-029 <b>214,60 €</b>	
KFF-U	0...100 % r. H.	–	0-10 V	–	1201-3111-0000-029 <b>166,10 €</b>	
KFF-U LCD	0...100 % r. H.	–	0-10 V	–	■ 1201-3111-0200-029 <b>214,60 €</b>	
<b>KFTF</b>				<b>IP65</b>		
KFTF-I	0...100 % r. H.	–35...+75 °C –35...+35 °C 0...+50 °C 0...+80 °C	4...20 mA	4...20 mA	1201-3112-1000-029 <b>170,34 €</b>	
KFTF-I LCD	0...100 % r. H.	(4x as above)	4...20 mA	4...20 mA	■ 1201-3112-1200-029 <b>218,85 €</b>	
KFTF-U	0...100 % r. H.	–35...+75 °C –35...+35 °C 0...+50 °C 0...+80 °C	0-10 V	0-10 V	1201-3111-1000-029 <b>170,34 €</b>	
KFTF-U LCD	0...100 % r. H.	(4x as above)	0-10 V	0-10 V	■ 1201-3111-1200-029 <b>218,85 €</b>	
<b>Housing variant:</b>	Cable connection <b>with cable gland</b> (M12 connector on request)					

HYGRASGARD® KFTF - U xx		Duct humidity and temperature sensors ( $\pm 2.0\%$ ), <i>Standard</i> (passive temperature sensor)				
Type / WG01	Measuring Range / Readout	Output	Item No.	Price		
	Humidity	Humidity				
	Temperature	Temperature				
<b>KFTF - U xx</b>	<b>Pt, Ni, LM235Z, NTC</b>	(active / passive)	<b>IP65</b>			
KFTF-U Pt100	0...100 % r. H.	–35...+75 °C –35...+35 °C 0...+50 °C 0...+80 °C	0-10 V	0-10 V + <b>Pt100</b>	1201-3111-2001-029 <b>177,01 €</b>	
KFTF-U Pt1000	0...100 % r. H.	(4x as above)	0-10 V	0-10 V + <b>Pt1000</b>	1201-3111-2005-029 <b>177,62 €</b>	
KFTF-U Ni1000	0...100 % r. H.	(4x as above)	0-10 V	0-10 V + <b>Ni1000</b>	1201-3111-2009-029 <b>178,23 €</b>	
KFTF-U NiTK	0...100 % r. H.	(4x as above)	0-10 V	0-10 V + <b>Ni1000TK5000</b>	1201-3111-2010-029 <b>179,19 €</b>	
KFTF-U LM235Z	0...100 % r. H.	(4x as above)	0-10 V	0-10 V + <b>LM235Z</b> , 10mV / K	1201-3111-2021-029 <b>177,98 €</b>	
KFTF-U NTC1,8K	0...100 % r. H.	(4x as above)	0-10 V	0-10 V + <b>NTC 1,8 kOhm</b>	1201-3111-2012-029 <b>178,23 €</b>	
KFTF-U NTC10K	0...100 % r. H.	(4x as above)	0-10 V	0-10 V + <b>NTC 10 kOhm</b>	1201-3111-2015-029 <b>177,13 €</b>	
KFTF-U NTC20K	0...100 % r. H.	(4x as above)	0-10 V	0-10 V + <b>NTC 20 kOhm</b>	1201-3111-2016-029 <b>177,13 €</b>	
<b>Housing variant:</b>	Cable connection <b>with cable gland</b> (M12 connector on request)					

Duct humidity and temperature sensors ( $\pm 1.8\%$ ),  
incl. mounting flange, calibratable, with multi-range switching  
and active output

**KFTF-20-Q**

with M12 connector,  
with display (Tyr2)

**KFTF-20-Q**

with M12 connector,  
without display (Tyr1)



**HYGRASGARD® KFTF-20-Q** Duct humidity and temperature sensors ( $\pm 1.8\%$ ), *Premium*  
(with M12 connector)

Type / WG02	Measuring Range / Readout Humidity	Temperature	Output Humidity	Temperature	Display ● = Q	Item No.	Price
<b>KFTF-20-Q</b>						<b>IP 65</b>	
KFTF-20-I Q	0...100% r. H.	-35...+75 °C -35...+35 °C 0...+50 °C 0...+80 °C	4... 20 mA	4... 20 mA	●	2003-4151-2100-001	<b>292,15 €</b>
KFTF-20-I Q LCD	0...100% r. H.	(4x as above)	4... 20 mA	4... 20 mA	● ■	2003-4172-2100-001	<b>338,22 €</b>
KFTF-20-U Q	0...100% r. H.	-35...+75 °C -35...+35 °C 0...+50 °C 0...+80 °C	0-10V	0-10V	●	2003-4151-1100-001	<b>292,15 €</b>
KFTF-20-U Q LCD	0...100% r. H.	(4x as above)	0-10V	0-10V	● ■	2003-4172-1100-001	<b>338,22 €</b>
<b>Housing variant "Q":</b>	Cable connection with M12 connector (male, 5-pin, A-code)						

**ACCESSORIES**

<b>SF-M</b>	<b>Metal sinter filter</b> , $\varnothing$ 16 mm, L = 32 mm, exchangeable stainless steel V4A (1.4404)	7000-0050-2200-100	<b>40,31 €</b>
-------------	--	--------------------	----------------

For further information, see chapter Accessories!





S+S REGELTECHNIK

**HYGRASGARD® KFF-20**  
**HYGRASGARD® KFTF-20**

Duct humidity and temperature sensors ( $\pm 1.8\%$ ),  
incl. mounting flange, calibratable, with multi-range switching  
and active output

**KFF-20 / KFTF-20**

with cable gland,  
with display (Tyr2)



**KFF-20 / KFTF-20**

with cable gland,  
without display (Tyr1)



HYGRASGARD® KFF-20		Duct humidity sensors ( $\pm 1.8\%$ ), <i>Premium</i> (with cable gland)					
Type / WG02	Measuring Range / Readout Humidity	Readout Temperature	Output Humidity	Temperature	Display	Item No.	Price
<b>KFF-20</b>						<b>IP65</b>	
KFF-20-I	0...100% r. H.	–	4... 20mA	–		1201-3112-0000-030	<b>229,75 €</b>
KFF-20-I LCD	0...100% r. H.	–	4... 20mA	–	■	1201-8112-0400-030	<b>278,25 €</b>
KFF-20-U	0...100% r. H.	–	0-10V	–		1201-3111-0000-030	<b>229,75 €</b>
KFF-20-U LCD	0...100% r. H.	–	0-10V	–	■	1201-8111-0400-030	<b>278,25 €</b>
<b>Housing variant:</b>	Cable connection <b>with cable gland</b> (M12 connector on request)						

HYGRASGARD® KFTF-20		Duct humidity and temperature sensors ( $\pm 1.8\%$ ), <i>Premium</i> (with cable gland)					
Type / WG02	Measuring Range / Readout Humidity	Readout Temperature	Output Humidity	Temperature	Display	Item No.	Price
<b>KFTF-20</b>						<b>IP65</b>	
KFTF-20-I	0...100% r. H.	–35...+75 °C –35...+35 °C 0...+50 °C 0...+80 °C	4... 20mA	4... 20mA		1201-3112-1000-030	<b>252,22 €</b>
KFTF-20-I LCD	0...100% r. H.	(4x as above)	4... 20mA	4... 20mA	■	1201-8112-1400-030	<b>298,30 €</b>
KFTF-20-U	0...100% r. H.	–35...+75 °C –35...+35 °C 0...+50 °C 0...+80 °C	0-10V	0-10V		1201-3111-1000-030	<b>252,22 €</b>
KFTF-20-U LCD	0...100% r. H.	(4x as above)	0-10V	0-10V	■	1201-8111-1400-030	<b>298,30 €</b>
<b>Housing variant:</b>	Cable connection <b>with cable gland</b> (M12 connector see <b>KFTF-20-Q</b> )						

ACCESSORIES								
<b>SF-M</b>	<b>Metal</b> sinter filter, $\varnothing$ 16 mm, L=32 mm, exchangeable stainless steel <b>V4A</b> (1.4404)						7000-0050-2200-100	<b>40,31 €</b>
For further information, see chapter Accessories!								

**Duct humidity and temperature sensors ( $\pm 1.8\%$ ),  
calibratable, with multi-range switching  
and active output**

Calibratable humidity and temperature sensor **HYGRASGARD® KFTF-20-VA** ( $\pm 1.8\%$ ) with metal sinter filter, rugged housing, **stainless steel V4A**, optionally with /without display, with cable gland or M12 connector according to DIN EN 61076-2-101.

It measures the relative humidity and the temperature of the air and converts the measurand into a standard signal of 0 - 10 V or 4...20 mA. It has four switchable temperature ranges and is applied in non-aggressive dust-free atmospheres in refrigeration, air conditioning, ventilation and clean room technology. These measuring transducers are designed for exact detection of humidity. A digital long-term stable sensor is used as measuring element for humidity measurement. The sensor is factory-calibrated; an environmental precision adjustment by an expert is possible.

#### TECHNICAL DATA

Power supply:	24 V AC ( $\pm 20\%$ ); 15...36 V DC for U variant 15...36 V DC for I variant, depending on working resistance, residual ripple stabilised $\pm 0.3V$
Working resistance:	$R_b \text{ (ohm)} = (U_b - 14 V) / 0.02 A$ for I variant, see load resistance diagram
Load resistance:	$R_L > 5 k\Omega$ for U variant
Sensors:	<b>digital humidity sensor with integrated temperature sensor</b> , low hysteresis, high long-term stability

#### HUMIDITY

Measuring range, humidity:	0...100% r. H.
Permitted humidity:	< 95% r. H., non-precipitating air
Deviation in humidity:	typically $\pm 1.8\%$ (10...90% r. H.) at +25 °C, otherwise $\pm 2.0\%$
Output humidity:	0 - 10 V for U variant 4...20 mA for I variant

#### TEMPERATURE

Measuring range, temperature:	<b>multi-range switching</b> (see table) <b>-35...+35 °C; -35...+75 °C; 0...+50 °C; 0...+80 °C</b>
Ambient temperature:	storage -35...+85 °C; operation -30...+80 °C, non-precipitating
Deviation, temperature:	typically $\pm 0.2 K$ at +25 °C
Output, temperature:	0 - 10 V for U variant 4...20 mA for I variant
Electrical connection:	2-, 3-, or 4-wire connection (see connection diagram), 0.14 - 1.5 mm <sup>2</sup> , via terminal screws
Cable connection:	<b>cable gland, stainless steel V2A</b> (1.4305) (M20 x 1.5; with strain relief, exchangeable, inner diameter 6 - 12 mm) or <b>M12 connector</b> (male, 5-pin, A-code) according to DIN EN 61076-2-101
Housing:	<b>stainless steel V4A</b> (1.4571), with non-distortion cover bolting, impact resistant, high EMI shielding, corrosion, temperature, weather- and UV-resistant
Housing dimensions:	143 x 97 x 61 mm (Tyr 2E)
Protective tube:	<b>made from stainless steel V2A</b> (1.4301), $\varnothing$ 16 mm, NL = 197 mm
Sensor protection:	<b>metal sinter filter</b> , $\varnothing$ 16 mm, L = 32 mm, exchangeable, stainless steel V4A (1.4404)
Process connection:	by screws via the mounting fixture on the housing
Long-term stability:	$\pm 1\%$ per year
Protection class:	III (according to EN 60730)
Protection type:	<b>IP 65</b> (according to EN 60529) Housing tested, TÜV SÜD, Report No. 713160960B (Skadi2)
Standards:	CE conformity according to EMC Directive 2014/30/EU, according to EN 61326-1, according to EN 61326-2-3
Optional:	<b>display with illumination</b> , three-line, cutout approx. 70 x 40 mm (W x H), to display the ACTUAL temperature and ACTUAL humidity
<b>ACCESSORIES</b>	(see table)

**KFTF-20-VA**  
with cable gland



**KFTF-20-VAQ**  
with M12 connector





Duct humidity and temperature sensors ( $\pm 1.8\%$ ),  
calibratable, with multi-range switching  
and active output



Dimensional drawing

KFTF-20-VA

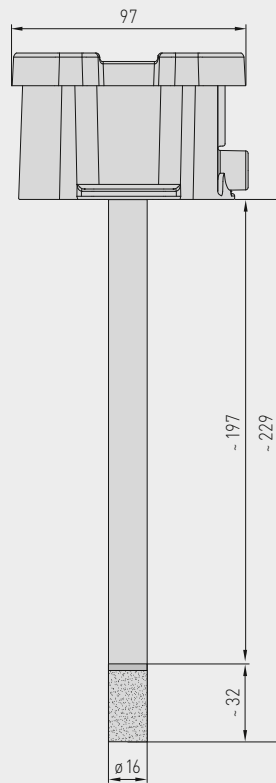
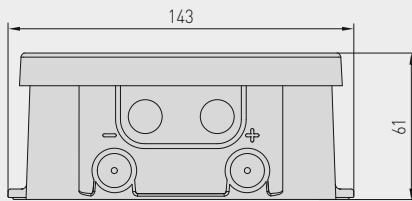

Housing with  
cable gland

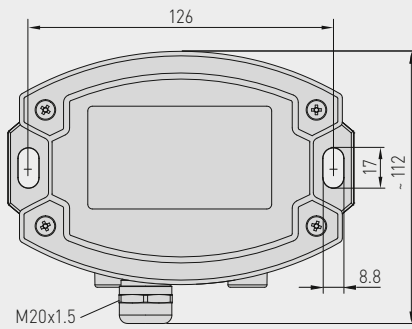

Housing with  
M12 connector

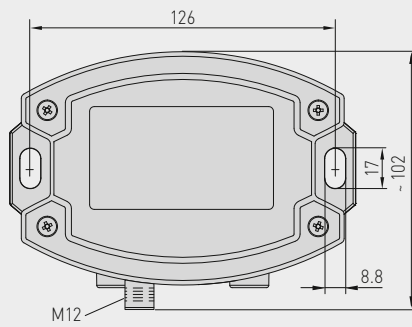

SF-M  
Metal sinter filter  
(standard)



M12 connector  
(male)

KFTF-20-VA  
with cable gland  
and display



KFTF-20-VAQ  
with M12 connector  
and display



Duct humidity and temperature sensors ( $\pm 1.8\%$ ),  
calibratable, with multi-range switching  
and active output

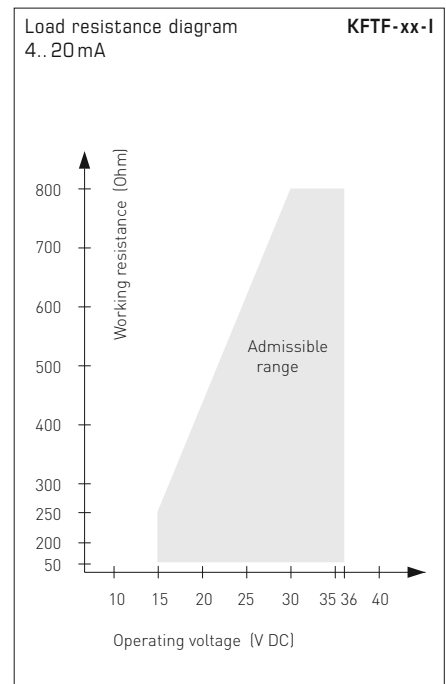
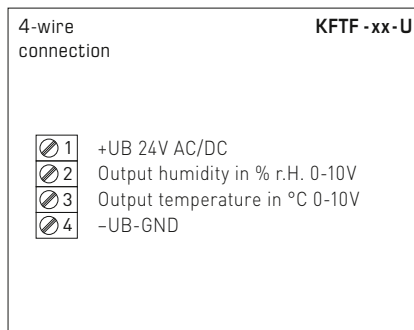
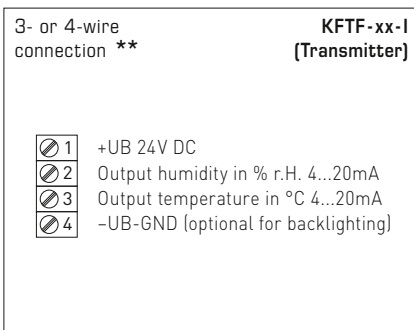
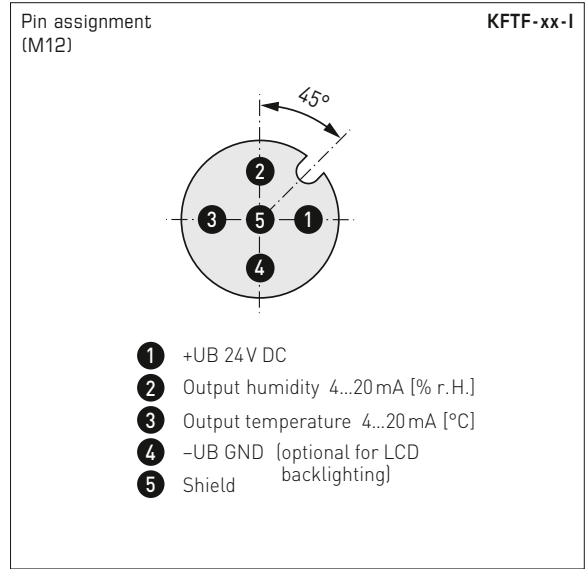
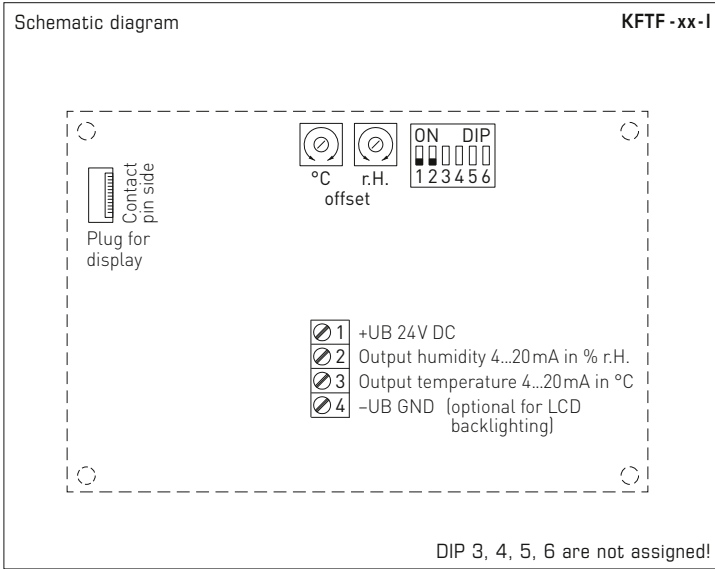
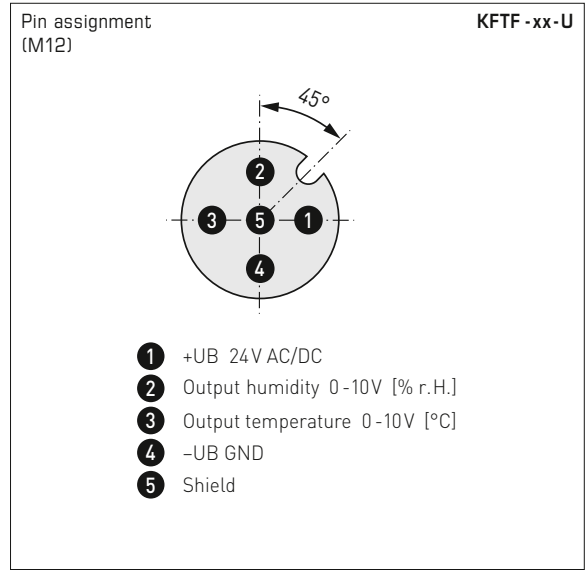
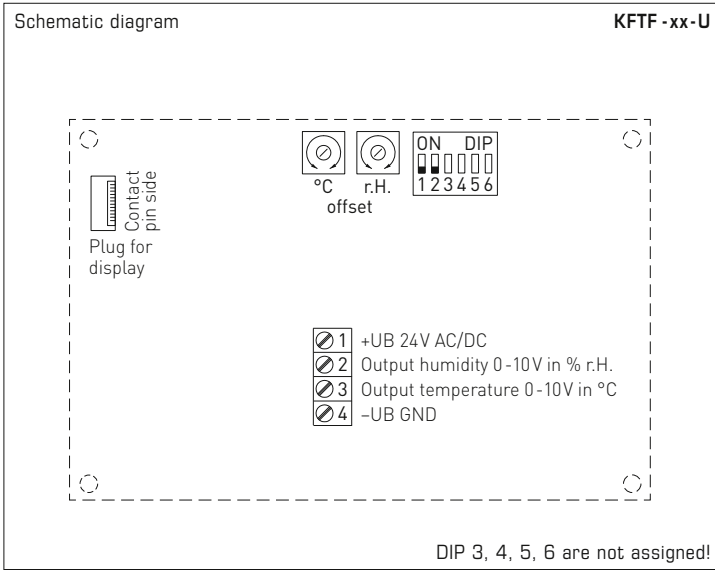

Connection\*\*:  
3-wire connection for devices with/without display (not illuminated)  
4-wire connection for devices with illuminated display

For the **I** variant the humidity path must be connected!

Temperature measuring ranges (adjustable)	DIP 1	DIP 2
-35...+75 °C	ON	ON
-35...+35 °C	OFF	OFF
<b>0...+50 °C (default)</b>	OFF	ON
0...+80 °C	ON	OFF



KFTF-20-VAQ  
with display,  
hinged



Temperature table  
MR: -35...+75 °C

°C	U <sub>A</sub> in V	I <sub>A</sub> in mA
-35	0.0	4.0
-30	0.5	4.7
-25	0.9	5.5
-20	1.4	6.2
-15	1.8	6.9
-10	2.3	7.6
-5	2.7	8.4
0	3.2	9.1
5	3.6	9.8
10	4.1	10.5
15	4.5	11.3
20	5.0	12.0
25	5.5	12.7
30	5.9	13.5
35	6.4	14.2
40	6.8	14.9
45	7.3	15.6
50	7.7	16.4
55	8.2	17.1
60	8.6	17.8
65	9.1	18.5
70	9.5	19.2
75	10.0	20.0

Temperature table  
MR: -35...+35 °C

°C	U <sub>A</sub> in V	I <sub>A</sub> in mA
-35	0.0	4.0
-30	0.7	5.1
-25	1.4	6.3
-20	2.1	7.4
-15	2.9	8.6
-10	3.6	9.7
-5	4.3	10.9
0	5.0	12.0
5	5.7	13.1
10	6.4	14.3
15	7.1	15.4
20	7.9	16.6
25	8.6	17.7
30	9.3	18.9
35	10.0	20.0

Temperature table  
MR: 0...+50 °C

°C	U <sub>A</sub> in V	I <sub>A</sub> in mA
0	0.0	4.0
5	1.0	5.6
10	2.0	7.2
15	3.0	8.8
20	4.0	10.4
25	5.0	12.0
30	6.0	13.6
35	7.0	15.2
40	8.0	16.8
45	9.0	18.4
50	10.0	20.0

Temperature table  
MR: 0...+80 °C

°C	U <sub>A</sub> in V	I <sub>A</sub> in mA
0	0.0	4.0
5	0.6	5.0
10	1.3	6.0
15	1.9	7.0
20	2.5	8.0
25	3.1	9.0
30	3.8	10.0
35	4.4	11.0
40	5.0	12.0
45	5.6	13.0
50	6.3	14.0
55	6.9	15.0
60	7.5	16.0
65	8.1	17.0
70	8.8	18.0
75	9.4	19.0
80	10.0	20.0

Humidity table  
MR: 0...100% r. H.

% r.H.	U <sub>A</sub> in V	I <sub>A</sub> in mA
0	0.0	4.0
5	0.5	4.8
10	1.0	5.6
15	1.5	6.4
20	2.0	7.2
25	2.5	8.0
30	3.0	8.8
35	3.5	9.6
40	4.0	10.4
45	4.5	11.2
50	5.0	12.0
55	5.5	12.8
60	6.0	13.6
65	6.5	14.4
70	7.0	15.2
75	7.5	16.0
80	8.0	16.8
85	8.5	17.6
90	9.0	18.4
95	9.5	19.2
100	10.0	20.0



Duct humidity and temperature sensors ( $\pm 1.8\%$ ),  
calibratable, with multi-range switching  
and active output

KFTF-20-VAQ  
with M12 connector



HYGRASGARD® KFTF-20-VAQ		Duct humidity and temperature sensors ( $\pm 1.8\%$ ), ID (with M12 connector)					
Type / WG02I	Measuring Range / Readout	Output	Display	Item No.	Price		
	Humidity	Humidity	● = Q				
	Temperature	Temperature					
<b>KFTF-20-VAQ</b>							
KFTF-20-I VAQ	0...100% r. H.	-35...+75 °C -35...+35 °C 0...+50 °C 0...+80 °C	4...20 mA	4...20 mA	●	2003-4161-2100-001	630,82 €
KFTF-20-I VAQ LCD	0...100% r. H.	(4x as above)	4...20 mA	4...20 mA	● ■	2003-4162-2100-001	778,82 €
KFTF-20-U VAQ	0...100% r. H.	-35...+75 °C -35...+35 °C 0...+50 °C 0...+80 °C	0-10V	0-10V	●	2003-4161-1100-001	630,82 €
KFTF-20-U VAQ LCD	0...100% r. H.	(4x as above)	0-10V	0-10V	● ■	2003-4162-1100-001	778,82 €
<b>Housing variant "Q":</b>	Cable connection with M12 connector (male, 5-pin, A-code)						

ACCESSORIES			
SF-M	Metal sinter filter, $\varnothing$ 16 mm, L = 32 mm, exchangeable stainless steel V4A (1.4404)	7000-0050-2200-100	40,31 €
For further information, see chapter Accessories!			



KFTF-20-VA  
with cable gland

HYGRASGARD® KFTF-20-VA		Duct humidity and temperature sensors ( $\pm 1.8\%$ ), <i>ID</i> (with cable gland)					
Type / WG02I	Measuring Range / Readout		Output		Display	Item No.	Price
	Humidity	Temperature	Humidity	Temperature			
<b>KFTF-20-VA</b>							
KFTF-20-I VA	0...100% r. H.	-35...+75 °C -35...+35 °C 0...+50 °C 0...+80 °C	4... 20 mA	4... 20 mA		2003-4161-2200-001	<b>594,12 €</b>
KFTF-20-I VA <b>LCD</b>	0...100% r. H.	(4x as above)	4... 20 mA	4... 20 mA	■	2003-4162-2200-001	<b>742,12 €</b>
KFTF-20-U VA	0...100% r. H.	-35...+75 °C -35...+35 °C 0...+50 °C 0...+80 °C	0-10 V	0-10 V		2003-4161-1200-001	<b>594,12 €</b>
KFTF-20-U VA <b>LCD</b>	0...100% r. H.	(4x as above)	0-10 V	0-10 V	■	2003-4162-1200-001	<b>742,12 €</b>
<b>Housing variant:</b>	Cable connection <b>with cable gland</b>						

ACCESSORIES			
<b>SF-M</b>	<b>Metal</b> sinter filter, $\varnothing$ 16 mm, L=32 mm, exchangeable stainless steel <b>V4A</b> (1.4404)	7000-0050-2200-100	<b>40,31 €</b>
For further information, see chapter Accessories!			



**Duct outdoor humidity sensors ( $\pm 2.0\%$ ), including mounting flange, for mixture ratio, relative/absolute humidity, dew point, enthalpy (switchable) and temperature, with multi-range switching, with active output**

The universal humidity sensors **HYGRASGARD® KAVTF** with 6 output sizes are used to determine diverse characteristic variables in humidity measurement. The relative humidity and temperature of the ambient air are measured. From these measurands, the different characteristic variables are internally calculated.

For device version x-U, two outputs of 0 - 10 V are available, for Version x-I two outputs of 4...20 mA. Here, the output variables for these outputs can be defined using DIP switches. Selectable for output 1 are relative humidity [% r.H.], absolute humidity [g/m<sup>3</sup>], mixture ratio [g/kg], dew point temperature [°C], or enthalpy [kJ/kg] (while neglecting the atmospheric air pressure). At output 2, four different measuring ranges for ambient temperature [°C] are selectable. Ex-factory condition (default) for output 1 is relative humidity 0...100% r.H., for output 2 temperature measuring range 0...+50 °C.

Due to the different configuration alternatives provided, numerous measurement and control tasks can be solved by just one device. These devices are to be operated in pollutant-free non-precipitating air, with neither above-atmospheric nor below-atmospheric pressure at the sensors. Application examples include medical technology, refrigeration, air conditioning, and clean room technology. These sensors are appropriate for duct installation.

**TECHNICAL DATA**

Power supply:	24 V AC ( $\pm 20\%$ ); 15...36 V DC for U variant 15...36 V DC for I variant, depending on working resistance, residual ripple stabilised $\pm 0.3V$
Working resistance:	$R_b(\text{ohm}) = (U_b - 14 V) / 0.02 A$ for I variant
Load resistance:	$R_L > 5 k\Omega$ for U variant
Power consumption:	$< 1 W$ at 24 V DC; $< 2 VA$ at 24 V AC
Sensors:	<b>digital humidity sensor with integrated temperature sensor</b> , low hysteresis, high long-term stability
Sensor protection:	<b>plastic sinter filter</b> , $\varnothing 16 \text{ mm}$ , $L = 35 \text{ mm}$ , exchangeable (optional <b>metal sinter filter</b> , $\varnothing 16 \text{ mm}$ , $L = 32 \text{ mm}$ )

**HUMIDITY**

Measuring range, humidity:	<b>multi-range switching with 8 switchable measuring ranges</b> (see table) 0...100% r.H. (default)
Operating range, humidity:	10...95% r.H., without formation of dew
Deviation, humidity:	typically $\pm 2.0\%$ (20...80% r.H.) at +25 °C, otherwise $\pm 3.0\%$ Deviations of other outputs result from deviations of humidity and temperature.
Output 1, humidity:	0 - 10 V for U variant (see table) 4...20 mA for I variant (see table)

**TEMPERATURE**

Measuring range, temperature:	<b>multi-range switching with 4 switchable measuring ranges</b> (see table) 0...+50 °C (default); -20...+80 °C; -35...+75 °C; -35...+35 °C
Operating range, temperature:	-35...+85 °C sensors
Deviation, temperature:	typically $\pm 0.2K$ at +25 °C
Output 2, temperature:	0 - 10 V for U variant (see table) 4...20 mA for I variant (see table)
Ambient temperature:	storage -35...+85 °C; operation -30...+70 °C, non-precipitating
Electrical connection:	4-wire connection for U variant 3-wire connection for I variant (Transmitter) 0.14 - 1.5 mm <sup>2</sup> , via terminal screws

Housing:	plastic, UV-resistant, material polyamide, 30% glass-globe reinforced, with quick-locking screws (slotted/Phillips head combination), colour traffic white (similar to RAL 9016), housing cover for display is transparent!
----------	---

Housing dimensions:	72 x 64 x 37.8 mm (Tyr 1 without display) 72 x 64 x 43.3 mm (Tyr 1 with display)
---------------------	---

Cable connection:	<b>cable gland</b> , plastic (M 16 x 1.5; with strain relief, exchangeable, max. inner diameter 10.4 mm) or <b>M12 connector</b> according to DIN EN 61076-2-101 (on request)
-------------------	---

Protective tube:	<b>PLEUROFORM™</b> , material polyamide (PA6), with torsion protection $\varnothing 20 \text{ mm}$ , $NL = 235 \text{ mm}$ , $v_{\text{max}} = 30 \text{ m/s}$ (air) (on request, optional <b>stainless steel V2A</b> (1.4301), $\varnothing 16 \text{ mm}$ )
------------------	--

Process connection:	by mounting flange, plastic (included in the scope of delivery)
---------------------	---

Protection class:	III (according to EN 60 730)
-------------------	------------------------------

Protection type:	<b>IP65</b> (according to EN 60 529) in the built-in state, Housing tested, TÜV SÜD, Report No. 713139052 (Tyr 1)
------------------	--

Standards:	CE conformity, electromagnetic compatibility according to EN 61 326, EMC directive 2014 / 30 / EU
------------	---

Optional:	two-line <b>display with illumination</b> , cutout approx. 36 x 15 mm (W x H), for displaying actual temperature and actual humidity, as well as the selectable output variables
-----------	--

**ACCESSORIES**

see last chapter

**SF-K**  
Plastic sinter filter (standard)



**SF-M**  
Metal sinter filter (optional)



**Protective tube stainless steel**  
(optional on request)

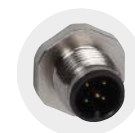

**M12 connector**  
(optional on request)



**MFT-20-K**  
Mounting flange, plastic



Dimensional drawing **MFT-20-K**

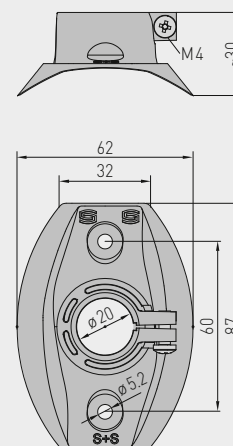



S+S REGELTECHNIK

HYGRASGARD® KAVTF

Duct outdoor humidity sensors ( $\pm 2.0\%$ ), including mounting flange, for mixture ratio, relative/absolute humidity, dew point, enthalpy (switchable) and temperature, with multi-range switching, with active output

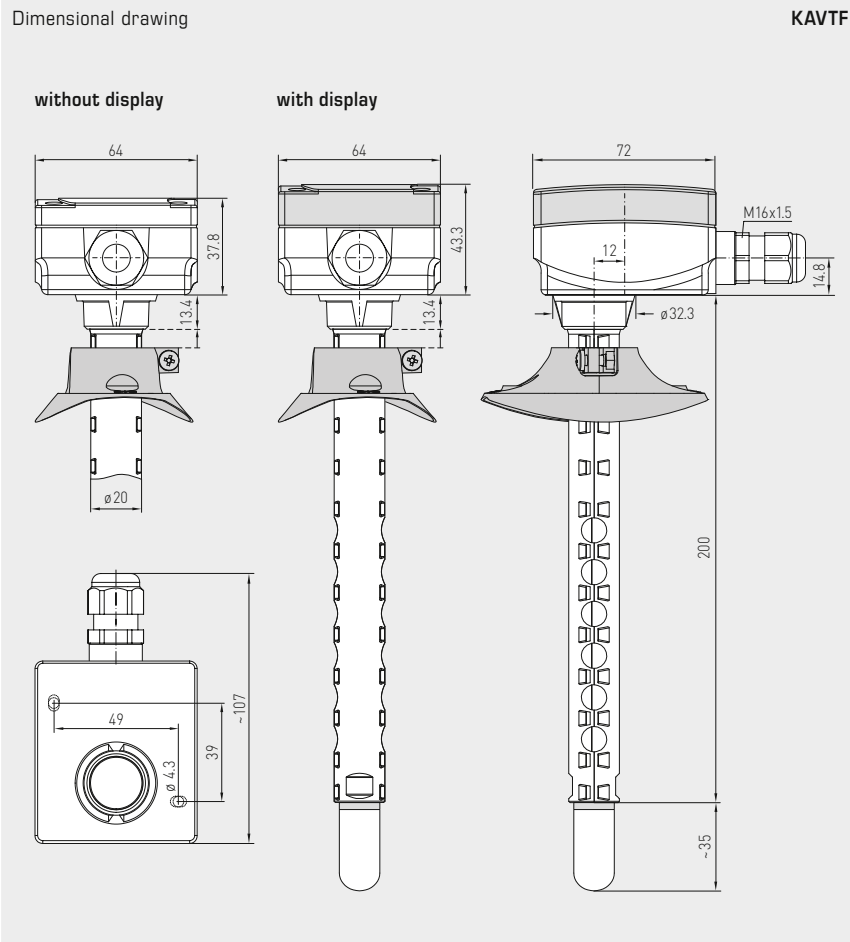

KAVTF

KAVTF with plastic sinter filter (standard)



Temperature table  
MR: -35...+75 °C

°C	U <sub>A</sub> in V	I <sub>A</sub> in mA
-35	0.0	4.0
-30	0.5	4.7
-25	0.9	5.5
-20	1.4	6.2
-15	1.8	6.9
-10	2.3	7.6
-5	2.7	8.4
0	3.2	9.1
5	3.6	9.8
10	4.1	10.5
15	4.5	11.3
20	5.0	12.0
25	5.5	12.7
30	5.9	13.5
35	6.4	14.2
40	6.8	14.9
45	7.3	15.6
50	7.7	16.4
55	8.2	17.1
60	8.6	17.8
65	9.1	18.5
70	9.5	19.2
75	10.0	20.0

Temperature table  
MR: -35...+35 °C

°C	U <sub>A</sub> in V	I <sub>A</sub> in mA
-35	0.0	4.0
-30	0.7	5.1
-25	1.4	6.3
-20	2.1	7.4
-15	2.9	8.6
-10	3.6	9.7
-5	4.3	10.9
0	5.0	12.0
5	5.7	13.1
10	6.4	14.3
15	7.1	15.4
20	7.9	16.6
25	8.6	17.7
30	9.3	18.9
35	10.0	20.0

Temperature table  
MR: 0...+50 °C

°C	U <sub>A</sub> in V	I <sub>A</sub> in mA
0	0.0	4.0
5	1.0	5.6
10	2.0	7.2
15	3.0	8.8
20	4.0	10.4
25	5.0	12.0
30	6.0	13.6
35	7.0	15.2
40	8.0	16.8
45	9.0	18.4
50	10.0	20.0

Temperature table  
MR: -20...+80 °C

°C	U <sub>A</sub> in V	I <sub>A</sub> in mA
-20	0.0	4.0
-15	0.5	4.8
-10	1.0	5.6
-5	1.5	6.4
0	2.0	7.2
5	2.5	8.0
10	3.0	8.8
15	3.5	9.6
20	4.0	10.4
25	4.5	11.2
30	5.0	12.0
35	5.5	12.8
40	6.0	13.6
45	6.5	14.4
50	7.0	15.2
55	7.5	16.0
60	8.0	16.8
65	8.5	17.6
70	9.0	18.4
75	9.5	19.2
80	10.0	20.0

Humidity table  
MR: 0...100 % r. H.

% r.H.	U <sub>A</sub> in V	I <sub>A</sub> in mA
0	0.0	4.0
5	0.5	4.8
10	1.0	5.6
15	1.5	6.4
20	2.0	7.2
25	2.5	8.0
30	3.0	8.8
35	3.5	9.6
40	4.0	10.4
45	4.5	11.2
50	5.0	12.0
55	5.5	12.8
60	6.0	13.6
65	6.5	14.4
70	7.0	15.2
75	7.5	16.0
80	8.0	16.8
85	8.5	17.6
90	9.0	18.4
95	9.5	19.2
100	10.0	20.0

Duct outdoor humidity sensors ( $\pm 2.0\%$ ), including mounting flange, for mixture ratio, relative/absolute humidity, dew point, enthalpy (switchable) and temperature, with multi-range switching, with active output

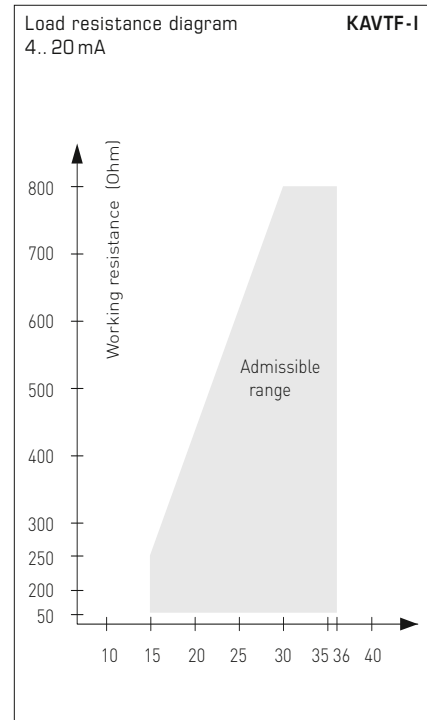
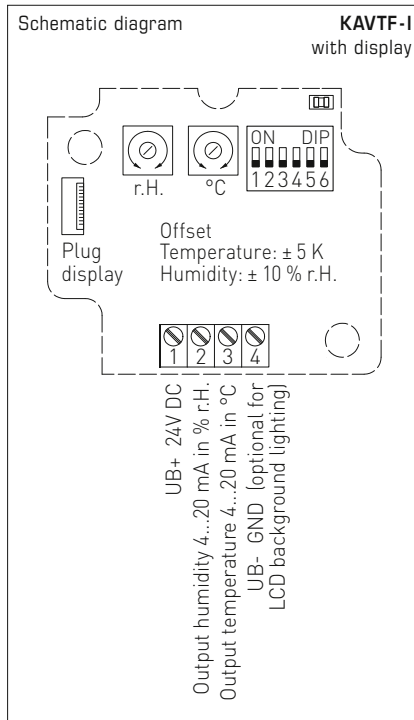
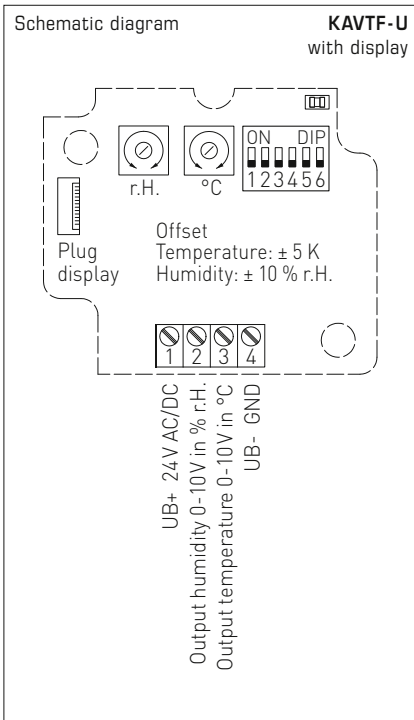

Temperature measuring ranges (adjustable)	DIP 1	DIP 2
0...+50 $^{\circ}\text{C}$ (default)	OFF	OFF
-20...+80 $^{\circ}\text{C}$	ON	OFF
-35...+75 $^{\circ}\text{C}$	OFF	ON
-35...+35 $^{\circ}\text{C}$	ON	ON

Switchable measuring ranges (adjustable)	DIP 3	DIP 4	DIP 5
r.H.: 0...100% (default)	OFF	OFF	OFF
MR: 0...50 g/kg	ON	OFF	OFF
MR: 0...80 g/kg	OFF	ON	OFF
A.H.: 0...50 g/m <sup>3</sup>	OFF	OFF	ON
A.H.: 0...80 g/m <sup>3</sup>	ON	ON	OFF
DP: 0...+50 $^{\circ}\text{C}$	ON	OFF	ON
DP: -20...+80 $^{\circ}\text{C}$	OFF	ON	ON
ENT.: 0...85 kJ/kg	ON	ON	ON

**Possible parameters:**

(r.H.) = relative humidity in %  
(MR) = mixture ratio in g/kg  
(A.H.) = absolute humidity in g/m<sup>3</sup>  
(DP) = dew point in  $^{\circ}\text{C}$   
(ENT.) = enthalpy in kJ/kg

Service display/output (adjustable)	DIP 6
Display $^{\circ}\text{C}$ and % r.H., output of set measurements via DIP 1-5 (service mode for setting $^{\circ}\text{C}$ and % r.H.)	ON
Display and output of set measurements via DIP 1-5	OFF

**KAVTF**  
with plastic sinter filter  
**SF-K** (standard)

**KAVTF**  
with metal sinter filter  
**SF-M** (optional)







Duct outdoor humidity sensors ( $\pm 2.0\%$ ), including mounting flange, for mixture ratio, relative/absolute humidity, dew point, enthalpy (switchable) and temperature, with multi-range switching, with active output

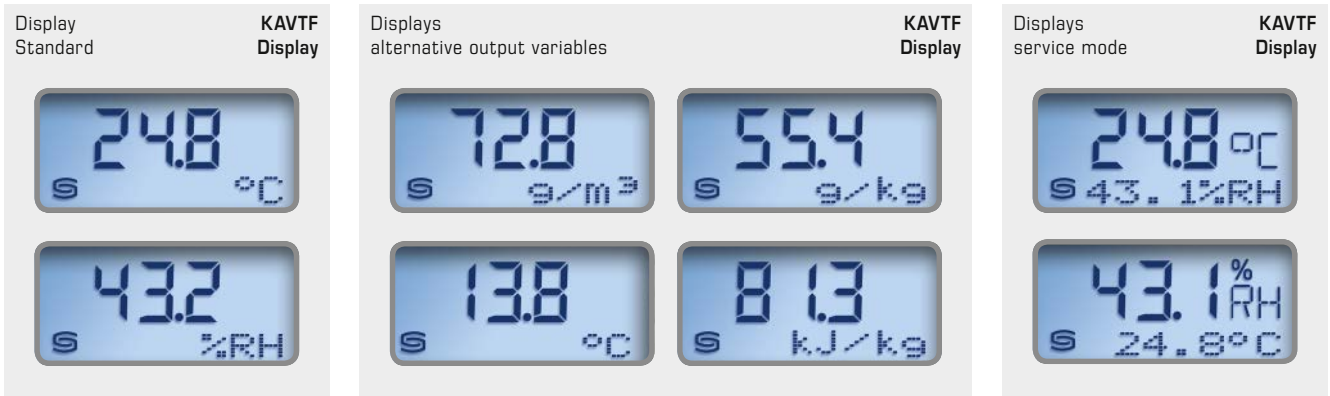

By default, the display alternates between the **actual temperature** and the **actual humidity** (relative humidity). In this case, the first line displays the value while the second line displays the corresponding unit:  
**Temperature in °C**  
**Relative humidity in % r.H.**  
 For improved legibility, backlighting is provided.

**DIP switches** can be used to display an **alternative output variable** instead of the standard display:  
**Absolute humidity in g/m<sup>3</sup>**  
**Dew point in °C**  
**Mixture ratio in g/kg**  
**Enthalpy in kJ/kg**

The **service mode** simultaneously displays (alternately in the first and second lines) the **actual temperature** and the **actual humidity** (relative humidity).



KAVTF with display

HYGRASGARD® KAVTF Duct outdoor humidity sensors ( $\pm 2.0\%$ )						
Type/ WG01	Measuring Range	Temperature	Output Humidity	Display Temperature	Item No.	Price
<b>KAVTF-I</b>	(switchable)	(switchable)			<b>I-variant</b>	
KAVTF-I	0...100% r.H. (default) 0...50 g/kg (MR) 0...80 g/kg (MR) 0...50 g/m <sup>3</sup> (A.H.) 0...80 g/m <sup>3</sup> (A.H.) 0...+50°C (DP) -20...+80°C (DP) 0...85 kJ/kg (ENT.)	0...+50°C (default) -20...+80°C -35...+75°C -35...+35°C	4...20 mA	4...20 mA	1201-3162-6000-029	<b>178,51 €</b>
KAVTF-I LCD	(8x as above)	(4x as above)	4...20 mA	4...20 mA	■ 1201-3162-6200-029	<b>236,11 €</b>
<b>KAVTF-U</b>					<b>U-variant</b>	
KAVTF-U	(8x as above)	(4x as above)	0-10V	0-10V	1201-3161-6000-029	<b>178,51 €</b>
KAVTF-U LCD	(8x as above)	(4x as above)	0-10V	0-10V	■ 1201-3161-6200-029	<b>236,11 €</b>
Extra charge:	Other non-standard ranges optional					<b>142,35 €</b>
Optional:	Cable connection with <b>M12 connector</b> according to DIN EN 61076-2-101					on request

ACCESSORIES			
<b>SF-M</b>	<b>Metal</b> sinter filter, Ø 16 mm, L = 32 mm, exchangeable stainless steel <b>V4A</b> (1.4404)	7000-0050-2200-100	<b>40,31 €</b>

**Pendulum room humidity sensors (± 2.0%),  
calibratable, with active output**

The calibratable pendulum room humidity sensor **HYGRASGARD® RPF - SD** with plastic sinter filter measures the relative humidity of air. It converts the measured humidity into a standard signal of 4...20 mA. Relative humidity (in % r. H.) is the quotient of water vapour partial pressure divided by the saturation vapour pressure at the respective gas temperature.

The sensor applied in non-aggressive dust-free atmospheres in refrigeration, air conditioning, ventilation and clean room technology, hotels, technical rooms, meeting rooms and convention centres. These measuring transducers are designed for precise detection of humidity. A digital long-term stable sensor is used as a measuring element for humidity measurement. This sensor is suitable for duct installation, as a pendulum sensor, or for integration in equipment.

**TECHNICAL DATA**

Power supply:	15...36 V DC depending on working resistance, residual ripple stabilised ± 0.3V
Working resistance:	$R_a \text{ (Ohm)} = (U_b - 14 \text{ V}) / 0.03 \text{ A}$ $R_a < 500 \text{ Ohm}$
Power consumption:	< 1.1 VA / 24 V DC
Sensors:	<b>digital humidity sensor</b> small hysteresis, high long-term stability
Sensor protection:	<b>plastic</b> sinter filter, Ø 16 mm, L = 35 mm, exchangeable (optional <b>metal</b> sinter filter, Ø 16 mm, L = 32 mm)
Measuring range, humidity:	0...100% r. H. (output corresponding to 4...20 mA)
Operating range, humidity:	0...95% r. H. (without formation of dew)
Deviation, humidity:	typically <b>± 2.0%</b> (20...80% r. H.) at +25 °C, otherwise ± 3.0%
Output, humidity:	4...20 mA, see load resistance diagram
Ambient temperature:	storage -25...+50 °C operation -5...+55 °C
Long-term stability:	± 1 % per year
Electrical connection:	2-wire connection (see connecting diagram), 0.14 - 1.5 mm <sup>2</sup>
Connection cable:	PVC, LiYY, 2 x 0.25 mm <sup>2</sup> , KL = approx. 1.5 m (other lengths optional)
Protective tube:	<b>stainless steel V2A</b> (1.4301), Ø = 16 mm, NL = 142 mm
Protection class:	III (according to EN 60 730)
Protection type:	<b>IP 65</b> (according to EN 60 529)
Standards:	CE conformity, according to EMC directive 2014 / 30 / EU, according to EN 61326-1, according to EN 61326-2-3
<b>ACCESSORIES</b>	see last chapter

**Humidity table**

MR: 0...100% r. H.

% r.H.	U <sub>A</sub> in V	I <sub>A</sub> in mA
0	0.0	4.0
5	0.5	4.8
10	1.0	5.6
15	1.5	6.4
20	2.0	7.2
25	2.5	8.0
30	3.0	8.8
35	3.5	9.6
40	4.0	10.4
45	4.5	11.2
50	5.0	12.0
55	5.5	12.8
60	6.0	13.6
65	6.5	14.4
70	7.0	15.2
75	7.5	16.0
80	8.0	16.8
85	8.5	17.6
90	9.0	18.4
95	9.5	19.2
100	10.0	20.0

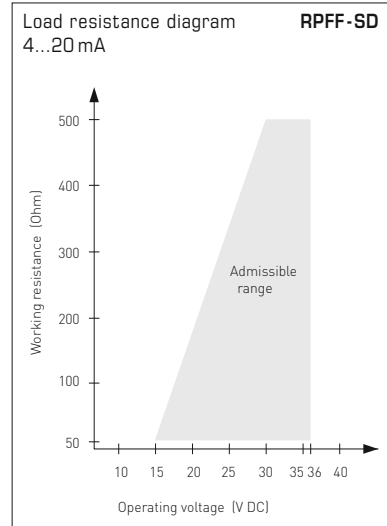

Circuit board

**RPF - SD**



2-wire  
connection

**RPF - SD - I**  
(Transmitter)

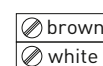

+UB 24V DC  
Output humidity  
in % r.H. 4-20mA

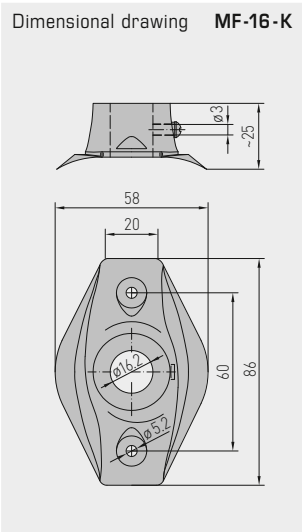

**MF-16-K**  
Mounting flange,  
plastic  
(optional)

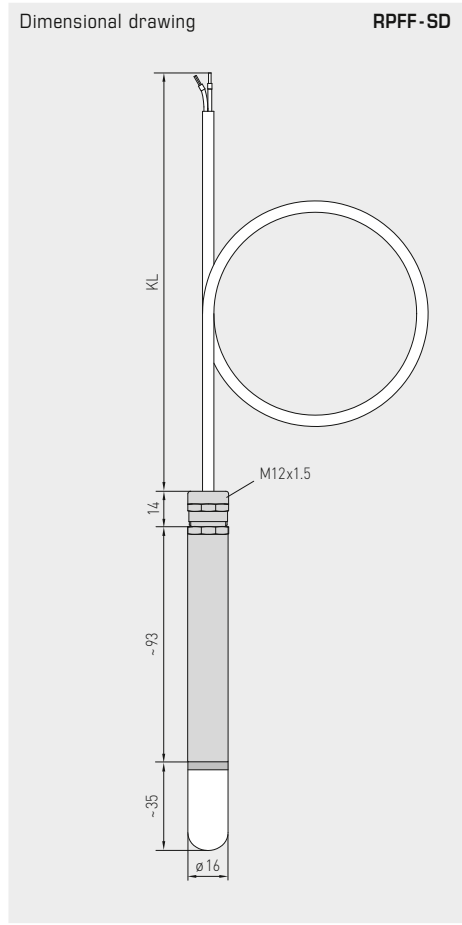

**RPFF-SD**  
with plastic sinter filter  
(standard)



**SF-M**  
Metal sinter filter  
(optional)



**HYGRASGARD® RPFF-SD** Pendulum room humidity sensors ( $\pm 2.0\%$ ), *Standard*

Type / WG01	Measuring Range Humidity (relative)	Output Humidity (relative)	Item No.	Price
<b>RPFF-SD-I</b>			<b>I-variant</b>	
RPFF-SD-I	0...100% r. H.	4...20 mA	1201-1172-0000-150	<b>148,69 €</b>
Extra charge:	<b>Cable length (KL)</b> 1.5 m, other lengths optional		on request	
For special orders please specify:	Type, cable length e.g. RPFF-SD-I, 3 m; RPFF-SD-I, 4 m			

**ACCESSORIES**

<b>SF-M</b>	<b>Metal sinter filter</b> , $\varnothing$ 16 mm, L = 32 mm, exchangeable stainless steel <b>V4A</b> (1.4404)	7000-0050-2200-100	<b>40,31 €</b>
<b>MF-16-K</b>	Mounting flange, plastic	7100-0030-0000-000	<b>9,10 €</b>

For further information see last chapter!

**Pendulum room humidity and temperature sensors ( $\pm 2.0\%$ ),  
calibratable, with multi-range switching  
and active output**

The calibratable pendulum room humidity and temperature sensor **HYGRASGARD® RPFF / RPFTF** with plastic sinter filter measures the relative humidity and temperature of air. It converts the measurands into standard signals of 0-10 V or 4...20 mA and is available with or without an optional display. It has four switchable temperature ranges. The sensor is applied in non-aggressive dust-free atmospheres in refrigeration, air conditioning, ventilation and clean room technology, hotels, technical rooms, meeting rooms and convention centres. These measuring transducers are designed for exact detection of temperature and humidity. A digital long-term stable sensor is used as a measuring element for humidity and temperature measurement. The sensor is appropriate for ceiling and duct installation, or for integrating it into equipment. The sensor is factory-calibrated; an environmental precision adjustment by an expert is possible.

**RPFF  
RPFTF**  
with plastic sinter filter  
(standard)



**TECHNICAL DATA**

Power supply:	24 V AC ( $\pm 20\%$ ); 15...36 V DC for U variant 15...36 V DC for I variant, depending on working resistance, residual ripple stabilised $\pm 0.3$ V
Working resistance:	$R_a(\text{ohm}) = (U_b - 14 \text{ V}) / 0.02 \text{ A}$ for I variant
Load resistance:	$R_L > 5 \text{ kOhm}$ for U variant
Power consumption:	$< 1.1 \text{ VA} / 24 \text{ V DC}$ ; $< 2.2 \text{ VA} / 24 \text{ V AC}$
Sensors:	<b>digital humidity sensor with integrated temperature sensor</b> , low hysteresis, high long-term stability
Sensor protection:	<b>plastic sinter filter</b> , $\varnothing 16 \text{ mm}$ , $L = 35 \text{ mm}$ , exchangeable (optional <b>metal sinter filter</b> , $\varnothing 16 \text{ mm}$ , $L = 32 \text{ mm}$ )

**HUMIDITY**

Measuring range, humidity:	0...100% r.H. (output corresponding to 0-10 V or 4...20 mA)
Operating range, humidity:	0...95% r.H. (without formation of dew)
Deviation, humidity:	typically $\pm 2.0\%$ (20...80% r.H.) at $+25^\circ\text{C}$ , otherwise $\pm 3.0\%$
Output, humidity:	0 - 10 V for U variant 4...20 mA for I variant, see load resistance diagram

**TEMPERATURE**

Measuring range, temperature:	<b>multi-range switching with 4 switchable measuring ranges</b> (see table) $-35...+35^\circ\text{C}$ ; $-35...+75^\circ\text{C}$ ; $0...+50^\circ\text{C}$ ; $0...+80^\circ\text{C}$ (output corresponding to 0-10 V or 4...20 mA)
Operating range, temperature:	$-35...+80^\circ\text{C}$
Deviation, temperature:	typically $\pm 0.2 \text{ K}$ at $+25^\circ\text{C}$
Output, temperature:	0-10 V or 4...20 mA or Ohm value
Ambient temperature:	storage $-5...+60^\circ\text{C}$ operation $-5...+60^\circ\text{C}$
Long-term stability:	$\pm 1\%$ per year
Housing:	plastic, UV-resistant, material polyamide, 30% glass-globe reinforced, with quick-locking screws (slotted / Phillips head combination), colour traffic white (similar to RAL 9016), housing cover for display is transparent!
Housing dimensions:	72 x 64 x 37.8 mm (Tyr 1 without display) 72 x 64 x 43.3 mm (Tyr 1 with display)
Cable connection:	<b>cable gland</b> , plastic (M 16 x 1.5; with strain relief, exchangeable, max. inner diameter 10.4 mm) <b>or</b> <b>M12 connector</b> according to DIN EN 61076-2-101 (on request)
Electrical connection:	2-, 3-, or 4-wire connection (see connecting diagram), 0.14 - 1.5 mm <sup>2</sup> via terminal screws
Connection cable:	PVC, LiYY, 6 x 0.14 mm <sup>2</sup> , KL = approx. 2 m (other lengths optional)
Protective tube:	<b>stainless steel V2A</b> (1.4301), $\varnothing = 16 \text{ mm}$ , NL = 142 mm
Protection class:	III (according to EN 60 730)
Protection type:	<b>IP 67</b> (according to EN 60 529) Housing tested TÜV SÜD, Report No. 713139052 (Tyr 1) <b>IP 65</b> (according to EN 60 529) Pendulum with sleeve
Standards:	CE conformity, according to EMC directive 2014 / 30 / EU, according to EN 61326-1, according to EN 61326-2-3
Optional:	two-line <b>display with illumination</b> , cutout approx. 36 x 15 mm (W x H), for displaying ACTUAL temperature and / or ACTUAL humidity

**ACCESSORIES**

see last chapter

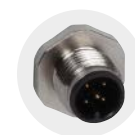

**M12 connector**  
(optional on request)

**MF-16-K**  
Mounting flange,  
plastic  
(optional)





S+S REGELTECHNIK

HYGRASGARD® RPFF  
HYGRASGARD® RPFTF

Pendulum room humidity and temperature sensors ( $\pm 2.0\%$ ),  
calibratable, with multi-range switching  
and active output



Dimensional drawing

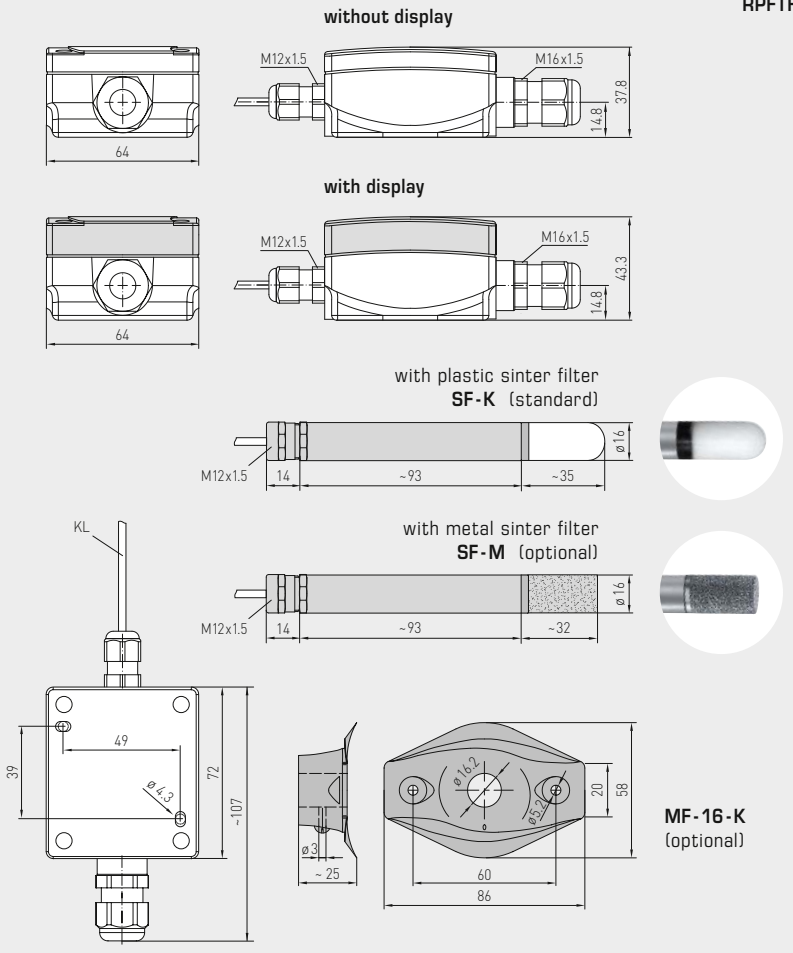

RPFF  
RPFTF

RPFF  
RPFTF  
with display and  
plastic sinter filter  
(standard)



Temperature table  
MR: -35...+75 °C

°C	U <sub>A</sub> in V	I <sub>A</sub> in mA
-35	0.0	4.0
-30	0.5	4.7
-25	0.9	5.5
-20	1.4	6.2
-15	1.8	6.9
-10	2.3	7.6
-5	2.7	8.4
0	3.2	9.1
5	3.6	9.8
10	4.1	10.5
15	4.5	11.3
20	5.0	12.0
25	5.5	12.7
30	5.9	13.5
35	6.4	14.2
40	6.8	14.9
45	7.3	15.6
50	7.7	16.4
55	8.2	17.1
60	8.6	17.8
65	9.1	18.5
70	9.5	19.2
75	10.0	20.0

Temperature table  
MR: -35...+35 °C

°C	U <sub>A</sub> in V	I <sub>A</sub> in mA
-35	0.0	4.0
-30	0.7	5.1
-25	1.4	6.3
-20	2.1	7.4
-15	2.9	8.6
-10	3.6	9.7
-5	4.3	10.9
0	5.0	12.0
5	5.7	13.1
10	6.4	14.3
15	7.1	15.4
20	7.9	16.6
25	8.6	17.7
30	9.3	18.9
35	10.0	20.0

Temperature table  
MR: 0...+50 °C

°C	U <sub>A</sub> in V	I <sub>A</sub> in mA
0	0.0	4.0
5	1.0	5.6
10	2.0	7.2
15	3.0	8.8
20	4.0	10.4
25	5.0	12.0
30	6.0	13.6
35	7.0	15.2
40	8.0	16.8
45	9.0	18.4
50	10.0	20.0

Temperature table  
MR: 0...+80 °C

°C	U <sub>A</sub> in V	I <sub>A</sub> in mA
0	0.0	4.0
5	0.6	5.0
10	1.3	6.0
15	1.9	7.0
20	2.5	8.0
25	3.1	9.0
30	3.8	10.0
35	4.4	11.0
40	5.0	12.0
45	5.6	13.0
50	6.3	14.0
55	6.9	15.0
60	7.5	16.0
65	8.1	17.0
70	8.8	18.0
75	9.4	19.0
80	10.0	20.0

Humidity table  
MR: 0...100% r. H.

% r.H.	U <sub>A</sub> in V	I <sub>A</sub> in mA
0	0.0	4.0
5	0.5	4.8
10	1.0	5.6
15	1.5	6.4
20	2.0	7.2
25	2.5	8.0
30	3.0	8.8
35	3.5	9.6
40	4.0	10.4
45	4.5	11.2
50	5.0	12.0
55	5.5	12.8
60	6.0	13.6
65	6.5	14.4
70	7.0	15.2
75	7.5	16.0
80	8.0	16.8
85	8.5	17.6
90	9.0	18.4
95	9.5	19.2
100	10.0	20.0



Pendulum room humidity and temperature sensors ( $\pm 2.0\%$ ),  
calibratable, with multi-range switching  
and active output

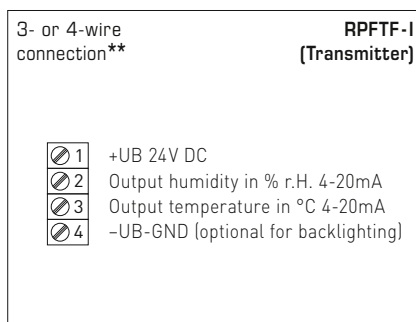
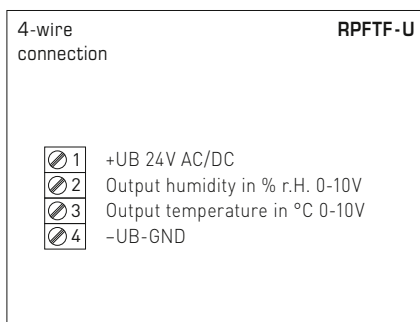
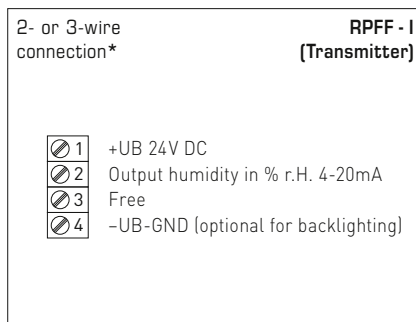
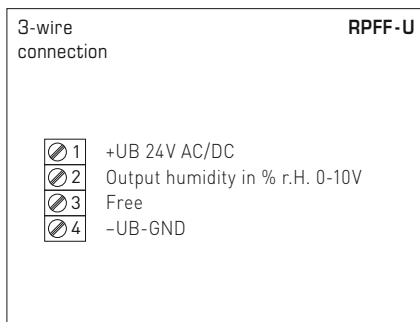
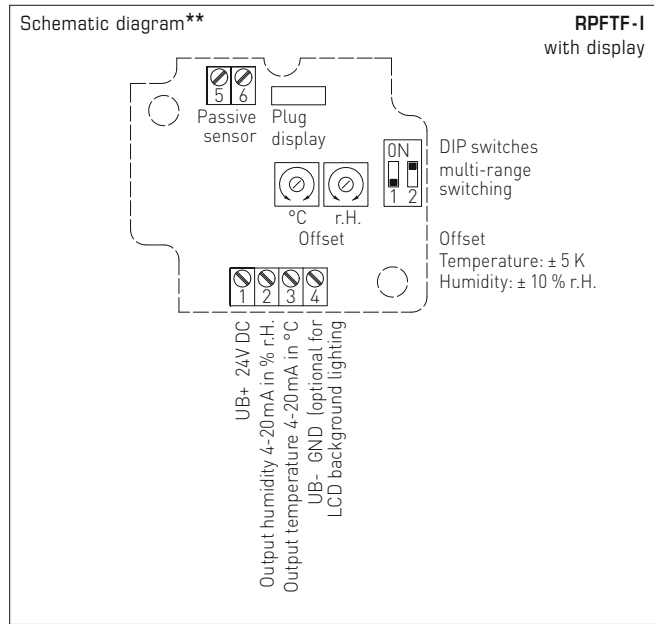
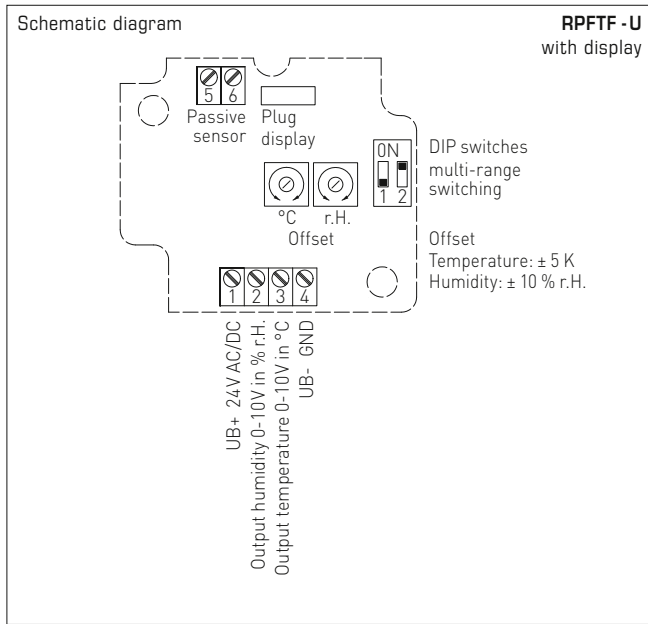

Temperature measuring ranges (adjustable)	DIP 1	DIP 2
-35...+75 °C	ON	ON
-35...+35 °C	OFF	OFF
<b>0...+50 °C (default)</b>	OFF	ON
0...+80 °C	ON	OFF

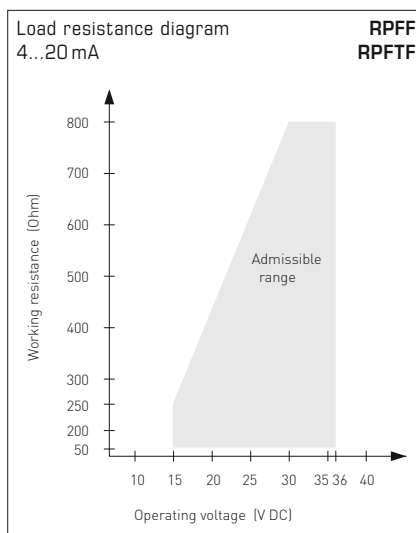

Connection\*:  
2-wire connection for devices with / without display (not illuminated)  
3-wire connection for devices with illuminated display

Connection\*\*:  
3-wire connection for devices with / without display (not illuminated)  
4-wire connection for devices with illuminated display

For the **I variant** the humidity path must be connected!



S+S REGELTECHNIK

HYGRASGARD® RPFF  
HYGRASGARD® RPFTF

Pendulum room humidity and temperature sensors ( $\pm 2.0\%$ ),  
calibratable, with multi-range switching  
and active output

RPFF  
RPFTF  
with display



HYGRASGARD® RPFF Pendulum room humidity sensors ( $\pm 2.0\%$ ), *Premium*  
HYGRASGARD® RPFTF Pendulum room humidity and temperature sensors ( $\pm 2.0\%$ ), *Premium*

Type / WG01	Measuring Range / Readout		Output		Item No.	Price
	Humidity	Temperature	Humidity	Temperature		
<b>RPFF</b>						
RPFF-I	0...100% r. H.	-	4...20 mA	-	1201-1172-0000-100	<b>189,13 €</b>
RPFF-U	0...100% r. H.	-	0-10 V	-	1201-1171-0000-100	<b>189,13 €</b>
<b>RPFTF</b>						
RPFTF-I	0...100% r. H.	-35...+75 °C -35...+35 °C 0...+50 °C 0...+80 °C	4...20 mA	4...20 mA	1201-1172-1000-100	<b>193,37 €</b>
RPFTF-U	0...100% r. H.	-35...+75 °C -35...+35 °C 0...+50 °C 0...+80 °C	0-10 V	0-10 V	1201-1171-1000-100	<b>193,37 €</b>
Extra charge:	Two-line <b>display with illumination</b> <b>Cable length</b> (KL = 2 m), other lengths optional up to max. 5 m					<b>47,46 €</b>
Optional:	Cable connection with <b>M12 connector</b> according to DIN EN 61076-2-101					on request

ACCESSORIES						
<b>SF-M</b>	<b>Metal sinter filter</b> , $\varnothing$ 16 mm, L = 32 mm, exchangeable stainless steel <b>V4A</b> (1.4404)				7000-0050-2200-100	<b>40,31 €</b>
<b>MF-16-K</b>	<b>Mounting flange</b> , plastic				7100-0030-0000-000	<b>9,10 €</b>
For further information see last chapter!						

Pendulum room humidity and temperature sensors ( $\pm 1.8\%$ ),  
calibratable, with multi-range switching  
and active output

The calibratable pendulum room humidity and temperature sensor **HYGRASGARD® RPFF-25/RPFTF-25** with pluggable metal sinter filter, housing made of impact-resistant plastic, with/without optional display.

It measures the relative humidity and/or the temperature of the air and converts the measurands into a standard signal of 0-10 V or 4...20 mA. It is equipped with four switchable temperature ranges. The sensor is applied in non-aggressive dust-free atmospheres in refrigeration, air conditioning, ventilation and clean room technology, hotels, technical rooms, meeting rooms and convention centres. These measuring transducers are designed for exact detection of temperature and humidity. A digital long-term stable sensor is used as measuring element for humidity and temperature measurement. The sensor is appropriate for ceiling and duct installation, or for integrating it into equipment. The sensor is factory-calibrated; an environmental precision adjustment by an expert is possible.

**RPFF-25/RPFTF-25** ( $\pm 1.8\%$ )  
pluggable measuring head  
with metal sinter filter



#### TECHNICAL DATA

Power supply:	24 V AC ( $\pm 20\%$ ); 15...36 V DC for U variant 15...36 V DC for I variant, depending on working resistance, residual ripple stabilised $\pm 0.3$ V
Working resistance:	$R_a$ (ohm) = $(U_b - 14 \text{ V}) / 0.02 \text{ A}$ for I variant
Load resistance:	$R_L > 5 \text{ k}\Omega$ for U variant
Power consumption:	$< 1.1 \text{ VA} / 24 \text{ V DC}$ ; $< 2.2 \text{ VA} / 24 \text{ V AC}$
Sensors:	<b>digital humidity sensor with integrated temperature sensor</b> , small hysteresis, high long-term stability, sensor head pluggable
Sensor protection:	<b>pluggable measuring head (probe) with metal sinter filter</b> , $\varnothing 16 \text{ mm}$ , $L = 88.5 \text{ mm}$ , exchangeable

#### HUMIDITY

Measuring range, humidity:	0...100% r. H. (output corresponding to 0-10 V or 4...20 mA)
Operating range, humidity:	0...95% r. H. (without formation of dew)
Deviation, humidity:	typically $\pm 1.8\%$ (10...90% r. H.) at $+25^\circ\text{C}$ , otherwise $\pm 2.0\%$
Output, humidity:	0-10 V for U variant 4...20 mA for I variant, see load resistance diagram

#### TEMPERATURE

Measuring range, temperature:	<b>multi-range switching with 4 switchable measuring ranges</b> (see table) $-35...+35^\circ\text{C}$ ; $-35...+75^\circ\text{C}$ ; $0...+50^\circ\text{C}$ ; $0...+80^\circ\text{C}$ (output corresponding to 0-10 V or 4...20 mA)
Deviation, temperature:	typically $\pm 0.2 \text{ K}$ at $+25^\circ\text{C}$
Output, temperature:	0-10 V or 4...20 mA or Ohm value
Ambient temperature:	storage $-35...+85^\circ\text{C}$ operation $-30...+70^\circ\text{C}$
Long-term stability:	$\pm 1\%$ per year
Electrical connection:	2-, 3-, or 4-wire connection (see connecting diagram), 0.14 - 1.5 mm <sup>2</sup> via terminal screws
Connection cable:	KL = 2 m
Housing:	plastic, UV-resistant, material polyamide, 30% glass-globe reinforced, with quick-locking screws (slotted / Phillips head combination), colour traffic white (similar to RAL 9016), housing cover for display is transparent!
Housing dimensions:	126 x 90 x 50 mm (Tyr 2)
Cable connection:	<b>cable gland</b> , plastic (M 16 x 1.5; with strain relief, exchangeable, max. inner diameter 10.4 mm) <b>or</b> <b>M12 connector</b> according to DIN EN 61076-2-101 (on request)
Protective tube:	<b>stainless steel V2A</b> (1.4301), $\varnothing = 18 \text{ mm}$ (16 mm), $L = 120 \text{ mm}$
Protection class:	III (according to EN 60 730)
Protection type:	<b>IP 65</b> (according to EN 60 529)
Standards:	CE conformity, according to EMC directive 2014 / 30 / EU, according to EN 61326-1, according to EN 61326-2-3
Optional:	three-line <b>display with illumination</b> , cutout approx. 70 x 40 mm (W x H), for displaying ACTUAL temperature and / or ACTUAL humidity

#### ACCESSORIES

see last chapter

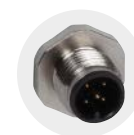

**M12 connector**  
(optional on request)

**MF-16-K**  
Mounting flange,  
plastic  
(optional)



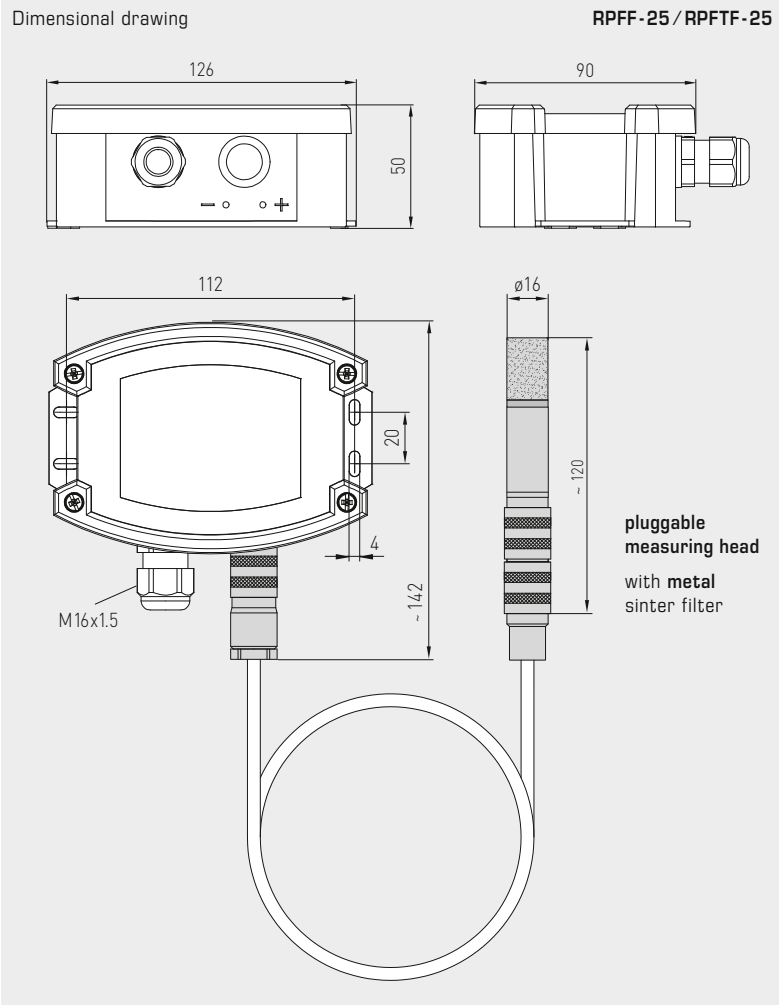

RPFF-25 / RPFTF-25 ( $\pm 1.8\%$ )  
pluggable measuring head  
with metal sinter filter  
and display



Temperature table  
MR:  $-35...+75\text{ }^{\circ}\text{C}$

$^{\circ}\text{C}$	$U_A$ in V	$I_A$ in mA
-35	0.0	4.0
-30	0.5	4.7
-25	0.9	5.5
-20	1.4	6.2
-15	1.8	6.9
-10	2.3	7.6
-5	2.7	8.4
0	3.2	9.1
5	3.6	9.8
10	4.1	10.5
15	4.5	11.3
20	5.0	12.0
25	5.5	12.7
30	5.9	13.5
35	6.4	14.2
40	6.8	14.9
45	7.3	15.6
50	7.7	16.4
55	8.2	17.1
60	8.6	17.8
65	9.1	18.5
70	9.5	19.2
75	10.0	20.0

Temperature table  
MR:  $-35...+35\text{ }^{\circ}\text{C}$

$^{\circ}\text{C}$	$U_A$ in V	$I_A$ in mA
-35	0.0	4.0
-30	0.7	5.1
-25	1.4	6.3
-20	2.1	7.4
-15	2.9	8.6
-10	3.6	9.7
-5	4.3	10.9
0	5.0	12.0
5	5.7	13.1
10	6.4	14.3
15	7.1	15.4
20	7.9	16.6
25	8.6	17.7
30	9.3	18.9
35	10.0	20.0

Temperature table  
MR:  $0...+50\text{ }^{\circ}\text{C}$

$^{\circ}\text{C}$	$U_A$ in V	$I_A$ in mA
0	0.0	4.0
5	1.0	5.6
10	2.0	7.2
15	3.0	8.8
20	4.0	10.4
25	5.0	12.0
30	6.0	13.6
35	7.0	15.2
40	8.0	16.8
45	9.0	18.4
50	10.0	20.0

Temperature table  
MR:  $0...+80\text{ }^{\circ}\text{C}$

$^{\circ}\text{C}$	$U_A$ in V	$I_A$ in mA
0	0.0	4.0
5	0.6	5.0
10	1.3	6.0
15	1.9	7.0
20	2.5	8.0
25	3.1	9.0
30	3.8	10.0
35	4.4	11.0
40	5.0	12.0
45	5.6	13.0
50	6.3	14.0
55	6.9	15.0
60	7.5	16.0
65	8.1	17.0
70	8.8	18.0
75	9.4	19.0
80	10.0	20.0

Humidity table  
MR:  $0...100\% \text{ r.H.}$

% r.H.	$U_A$ in V	$I_A$ in mA
0	0.0	4.0
5	0.5	4.8
10	1.0	5.6
15	1.5	6.4
20	2.0	7.2
25	2.5	8.0
30	3.0	8.8
35	3.5	9.6
40	4.0	10.4
45	4.5	11.2
50	5.0	12.0
55	5.5	12.8
60	6.0	13.6
65	6.5	14.4
70	7.0	15.2
75	7.5	16.0
80	8.0	16.8
85	8.5	17.6
90	9.0	18.4
95	9.5	19.2
100	10.0	20.0

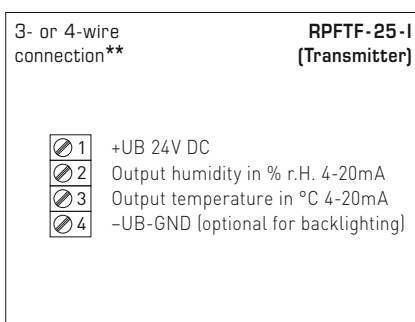
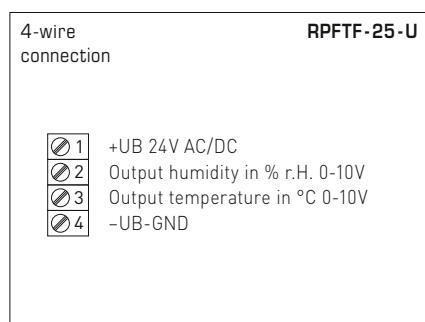
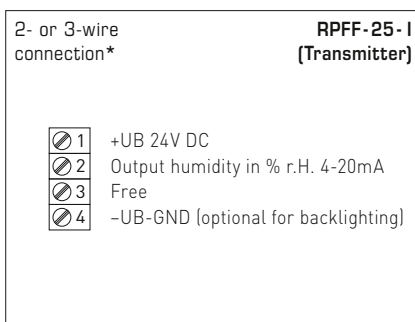
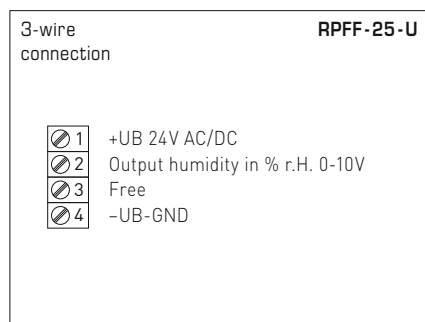
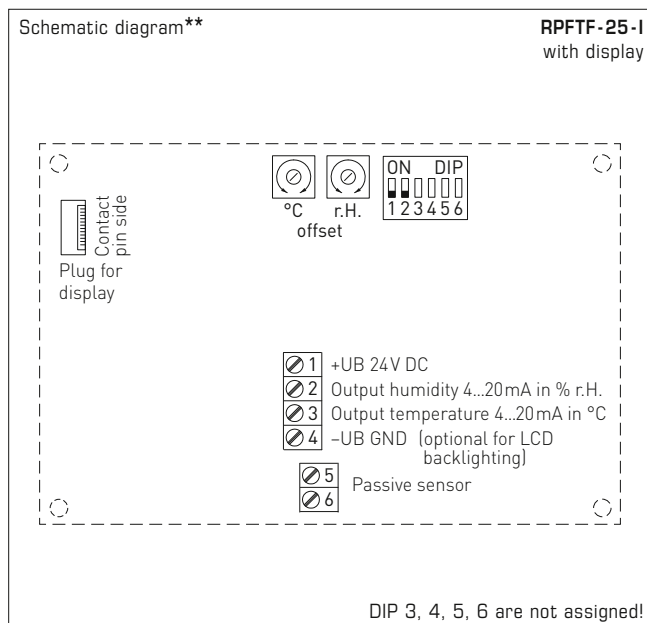
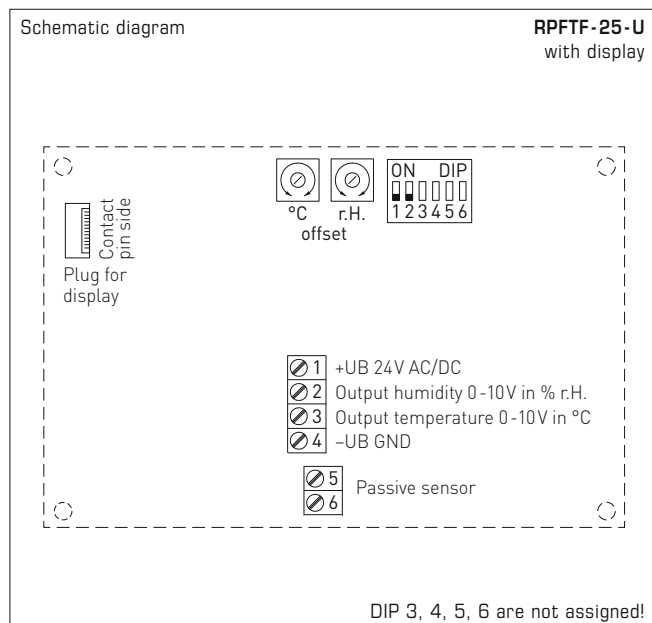

Temperature measuring ranges (adjustable)	DIP 1	DIP 2
-35...+75 °C	ON	ON
-35...+35 °C	OFF	OFF
0...+50 °C (default)	OFF	ON
0...+80 °C	ON	OFF

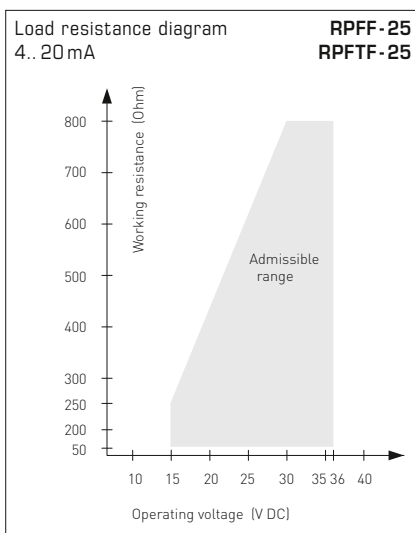

Connection\*:  
2-wire connection for devices with / without display (not illuminated)  
3-wire connection for devices with illuminated display

Connection\*\*:  
3-wire connection for devices with / without display (not illuminated)  
4-wire connection for devices with illuminated display

For the **I variant** the humidity path must be connected!





S+S REGELTECHNIK

**HYGRASGARD® RPFF - 25**  
**HYGRASGARD® RPFTF - 25**

Pendulum room humidity and temperature sensors ( $\pm 1.8\%$ ),  
calibratable, with multi-range switching  
and active output

RPFF-25 / RPFTF-25 ( $\pm 1.8\%$ )  
with display



**HYGRASGARD® RPFF - 25** Pendulum room humidity sensors, pluggable ( $\pm 1.8\%$ ), *Deluxe*  
**HYGRASGARD® RPFTF - 25** Pendulum room humidity and temperature sensors, pluggable ( $\pm 1.8\%$ ), *Deluxe*

Type / WG02	Measuring Range / Readout		Output		Display	Item No.	Price
	Humidity	Temperature	Humidity	Temperature			
<b>RPFF-25-I</b>							
<b>I-variant</b>							
RPFF-25-I	0...100 % r. H.	–	4... 20 mA	–		1201-7122-0000-100	<b>394,02 €</b>
RPFF-25-I LCD	0...100 % r. H.	–	4... 20 mA	–	■	1201-7122-0400-100	<b>441,47 €</b>
<b>RPFF-25-U</b>							
<b>U-variant</b>							
RPFF-25-U	0...100 % r. H.	–	0-10 V	–		1201-7121-0000-100	<b>394,02 €</b>
RPFF-25-U LCD	0...100 % r. H.	–	0-10 V	–	■	1201-7121-0400-100	<b>441,47 €</b>
<b>RPFTF-25-I</b>							
<b>I-variant</b>							
RPFTF-25-I	0...100 % r. H.	–35...+75 °C –35...+35 °C 0...+50 °C 0...+80 °C	4... 20 mA	4... 20 mA		1201-7122-1000-100	<b>414,64 €</b>
RPFTF-25-I LCD	0...100 % r. H.	(4x as above)	4... 20 mA	4... 20 mA	■	1201-7122-1400-100	<b>462,09 €</b>
<b>RPFTF-25-U</b>							
<b>U-variant</b>							
RPFTF-25-U	0...100 % r. H.	–35...+75 °C –35...+35 °C 0...+50 °C 0...+80 °C	0-10 V	0-10 V		1201-7121-1000-100	<b>414,64 €</b>
RPFTF-25-U LCD	0...100 % r. H.	(4x as above)	0-10 V	0-10 V	■	1201-7121-1400-100	<b>462,09 €</b>
Optional:	Cable connection with <b>M12 connector</b> according to DIN EN 61076-2-101						on request

<b>ACCESSORIES</b>			
<b>MSK-25</b>	Pluggable measuring head (sensor), stainless steel V2A (1.4301), metal sinter filter, Ø 16 mm, L = 88.5 mm, exchangeable, as replacement element for RPFF-25/RPFTF-25	7201-1131-0000-000	<b>204,90 €</b>
<b>MF-16-K</b>	Mounting flange, plastic	7100-0030-0000-000	<b>9,10 €</b>

For further information see last chapter!

Showcase humidity and temperature sensors ( $\pm 2.0\%$ ),  
calibratable, with multi-range switching  
and active output

The calibratable humidity and temperature sensor **HYGRASGARD® VFF / VFTF** measures the relative humidity and temperature of air. It converts the measurands humidity and temperature into a standard signal of 0-10V or 4...20mA, and is available with / without an optional display. It is equipped with four switchable temperature ranges. Relative humidity (in % r.H.) is the quotient of water vapour partial pressure divided by the saturation vapour pressure at the respective gas temperature. The measuring transducers are designed for exact detection of temperature and humidity. A digital, long-term stable sensor is used as a measuring element for humidity and temperature measurement. The sensor is factory-calibrated; an environmental precision adjustment by an expert is possible.

The showcase sensor is used in non-aggressive, dust-free environments and is specifically designed for installation in ceilings, walls, inside showcases or display cabinets in museums, galleries, cinemas or lecture halls or laboratories. The measuring element is contained inside a stainless steel probe and its low height (approx. 2.5 mm) makes it barely noticeable.

#### TECHNICAL DATA

Power supply:	24 V AC ( $\pm 20\%$ ) and 15...36 V DC for U variant 15...36 V DC for I variant, depending on working resistance, residual ripple stabilised $\pm 0.3$ V
Working resistance:	$R_a$ (Ohm) = $(U_b - 14 V) / 0.02 A$ for I variant
Load resistance:	$R_L > 5 k\Omega$ for U variant
Power consumption:	$< 1.1 VA / 24 V DC$ ; $< 2.2 VA / 24 V AC$
Sensors:	<b>digital humidity sensor with integrated temperature sensor</b> , low hysteresis, high long-term stability

#### HUMIDITY

Measuring range, humidity:	0...100% r.H. (output corresponding to 0-10V or 4...20mA)
Operating range, humidity:	0...95% r.H. (without formation of dew)
Deviation in humidity:	typically $\pm 2.0\%$ (20...80% r.H.) at $+25^\circ C$ , otherwise $\pm 3.0\%$
Output, humidity:	0-10V for U variant 4...20 mA for I variant, see load resistance diagram

#### TEMPERATURE

Measuring range, temperature:	<b>multi-range switching with 4 switchable measuring ranges</b> (see table) $-35...+35^\circ C$ ; $-35...+75^\circ C$ ; $0...+50^\circ C$ ; $0...+80^\circ C$ (output corresponding to 0-10V or 4...20mA)
Deviation, temperature:	typically $\pm 0.2 K$ at $+25^\circ C$
Output, temperature:	0-10V or 4...20mA
Ambient temperature:	storage $-5...+60^\circ C$ ; operation $-5...+60^\circ C$
Long-term stability:	$\pm 1\%$ per year
Housing:	plastic, UV-resistant, material polyamide, 30% glass-globe reinforced, with quick-locking screws (slotted / Phillips head combination), colour traffic white (similar to RAL 9016), housing cover for display is transparent!
Housing dimensions:	72 x 64 x 37.8 mm (Tyr 1 without display) 72 x 64 x 43.3 mm (Tyr 1 with display)
Cable connection:	<b>cable gland</b> , plastic (M 16 x 1.5; with strain relief, exchangeable, max. inner diameter 10.4 mm) <b>or</b> <b>M12 connector</b> according to DIN EN 61076-2-101 (optional on request)
Electrical connection:	2-, 3-, or 4-wire connection (see connecting diagram), 0.14 - 1.5 mm <sup>2</sup> , via terminal screws
Connecting cable:	PVC, LiYY, 4 x 0.14 mm <sup>2</sup> , cable length (KL) = 2 m
Sensor protection:	<b>probe</b> made of stainless steel, <b>V4A</b> (1.4571), <b>pluggable</b> ; sensor head $\varnothing = 17$ mm, H = approx. 2.5 mm; protective sleeve $\varnothing = 10$ mm, NL = approx. 25 mm, M10 x 1.0; with plastic plug connector $\varnothing =$ approx. 11 mm, NL = approx. 25 mm,
Mounting (sensor):	cut-out $\varnothing = 11 - 15$ mm, inserted length (EL) = approx. 50 mm, lock nut for fixing is included in the scope of delivery.
Protection class:	III (according to EN 60 730)
Protection type:	<b>IP 67</b> (according to EN 60 529) Housing tested, TÜV SÜD, Report No. 713139052 (Tyr 1) <b>IP 65</b> (according to EN 60 529) Probe
Standards:	CE conformity according to EMC Directive 2014 / 30 / EU, according to EN 61326-1, according to EN 61326-2-3
Optional:	two-line <b>display with illumination</b> , cut-out approx. 36 x 15 mm (W x H), for displaying ACTUAL temperature and / or ACTUAL humidity

VFF  
VFTF

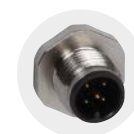

**M12 connector**  
(optional on request)

VFF  
VFTF

Probe made of stainless steel,  
pluggable





Dimensional drawing

VFF  
VFTF

VFF  
VFTF  
with display

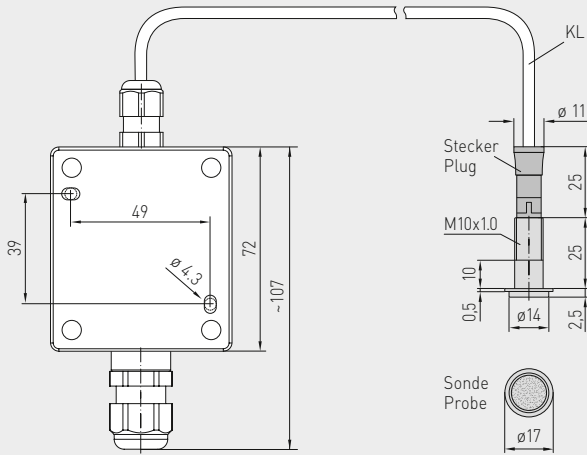
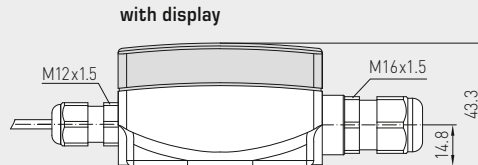
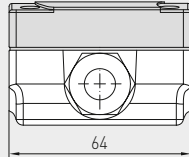
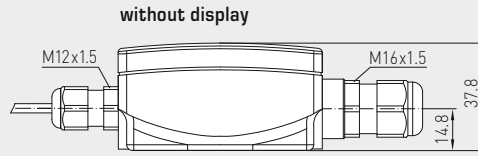
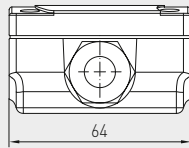

Temperature table  
MR: -35...+75 °C

°C	U <sub>A</sub> in V	I <sub>A</sub> in mA
-35	0.0	4.0
-30	0.5	4.7
-25	0.9	5.5
-20	1.4	6.2
-15	1.8	6.9
-10	2.3	7.6
-5	2.7	8.4
0	3.2	9.1
5	3.6	9.8
10	4.1	10.5
15	4.5	11.3
20	5.0	12.0
25	5.5	12.7
30	5.9	13.5
35	6.4	14.2
40	6.8	14.9
45	7.3	15.6
50	7.7	16.4
55	8.2	17.1
60	8.6	17.8
65	9.1	18.5
70	9.5	19.2
75	10.0	20.0

Temperature table  
MR: -35...+35 °C

°C	U <sub>A</sub> in V	I <sub>A</sub> in mA
-35	0.0	4.0
-30	0.7	5.1
-25	1.4	6.3
-20	2.1	7.4
-15	2.9	8.6
-10	3.6	9.7
-5	4.3	10.9
0	5.0	12.0
5	5.7	13.1
10	6.4	14.3
15	7.1	15.4
20	7.9	16.6
25	8.6	17.7
30	9.3	18.9
35	10.0	20.0

Temperature table  
MR: 0...+50 °C

°C	U <sub>A</sub> in V	I <sub>A</sub> in mA
0	0.0	4.0
5	1.0	5.6
10	2.0	7.2
15	3.0	8.8
20	4.0	10.4
25	5.0	12.0
30	6.0	13.6
35	7.0	15.2
40	8.0	16.8
45	9.0	18.4
50	10.0	20.0

Temperature table  
MR: 0...+80 °C

°C	U <sub>A</sub> in V	I <sub>A</sub> in mA
0	0.0	4.0
5	0.6	5.0
10	1.3	6.0
15	1.9	7.0
20	2.5	8.0
25	3.1	9.0
30	3.8	10.0
35	4.4	11.0
40	5.0	12.0
45	5.6	13.0
50	6.3	14.0
55	6.9	15.0
60	7.5	16.0
65	8.1	17.0
70	8.8	18.0
75	9.4	19.0
80	10.0	20.0

Humidity table  
MR: 0...100% r. H.

% r.H.	U <sub>A</sub> in V	I <sub>A</sub> in mA
0	0.0	4.0
5	0.5	4.8
10	1.0	5.6
15	1.5	6.4
20	2.0	7.2
25	2.5	8.0
30	3.0	8.8
35	3.5	9.6
40	4.0	10.4
45	4.5	11.2
50	5.0	12.0
55	5.5	12.8
60	6.0	13.6
65	6.5	14.4
70	7.0	15.2
75	7.5	16.0
80	8.0	16.8
85	8.5	17.6
90	9.0	18.4
95	9.5	19.2
100	10.0	20.0

Showcase humidity and temperature sensors ( $\pm 2.0\%$ ),  
calibratable, with multi-range switching  
and active output

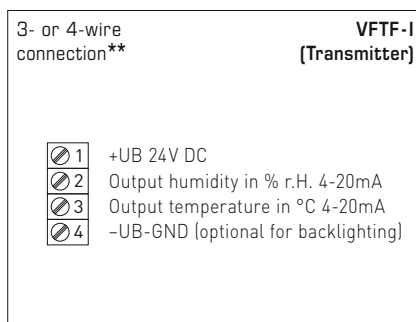
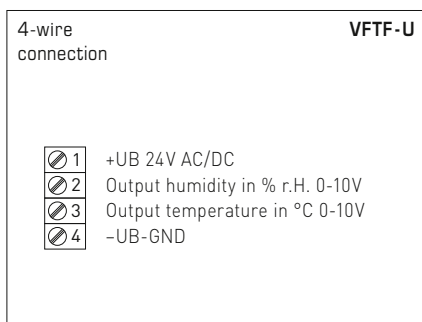
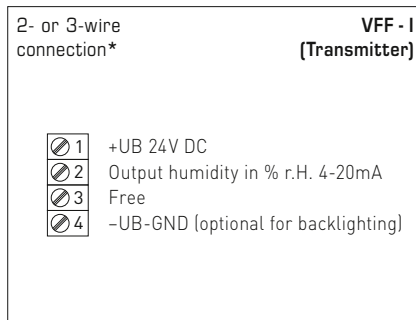
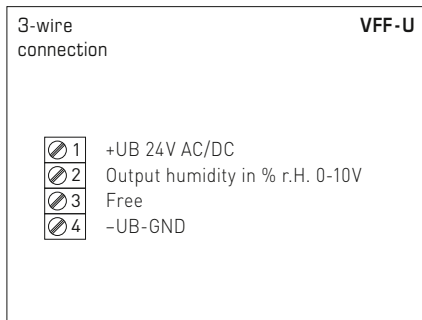
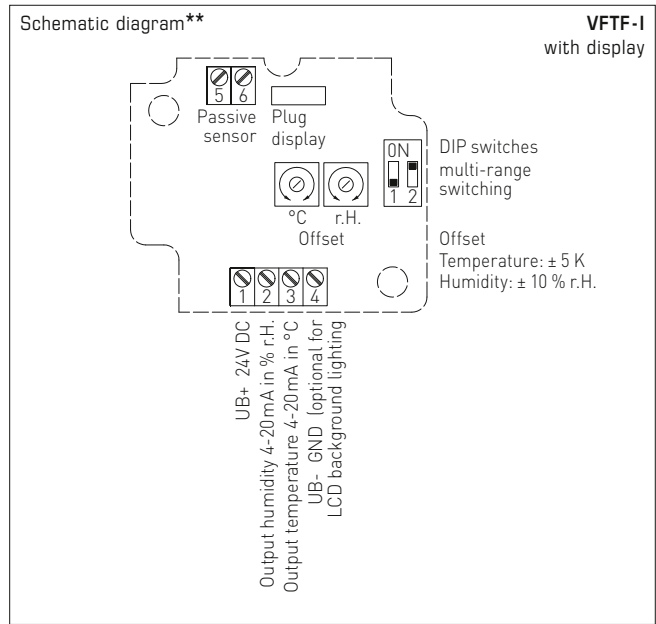
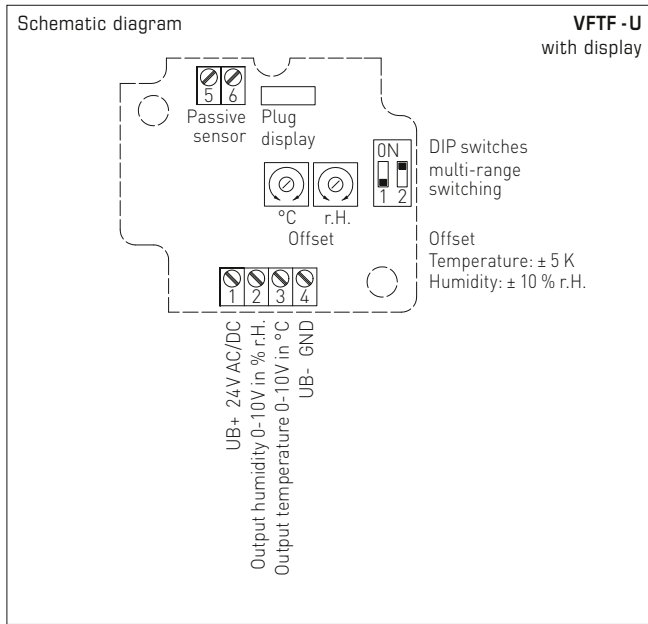

Temperature measuring ranges (adjustable)	DIP 1	DIP 2
-35...+75 $^{\circ}$ C	ON	ON
-35...+35 $^{\circ}$ C	OFF	OFF
0...+50 $^{\circ}$ C (default)	OFF	ON
0...+80 $^{\circ}$ C	ON	OFF

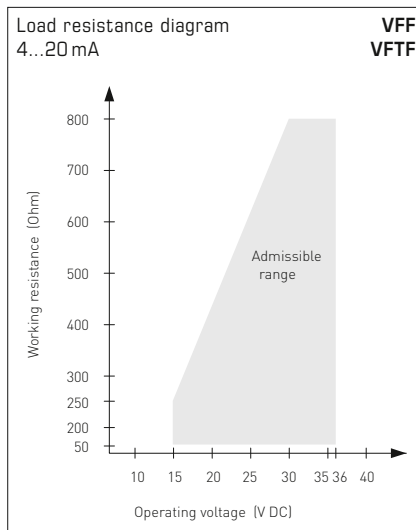

Connection\*:  
2-wire connection for devices with / without display (not illuminated)  
3-wire connection for devices with illuminated display

Connection\*\*:  
3-wire connection for devices with / without display (not illuminated)  
4-wire connection for devices with illuminated display

For the **I variant** the humidity path must be connected!



S+S REGELTECHNIK

HYGRASGARD® VFF  
HYGRASGARD® VFTF

Showcase humidity and temperature sensors ( $\pm 2.0\%$ ),  
calibratable, with multi-range switching  
and active output

VFF  
VFTF  
with display



HYGRASGARD® VFF		Showcase humiditysensor ( $\pm 2.0\%$ ), Premium					
HYGRASGARD® VFTF		Showcase humidity- and temperature sensor ( $\pm 2.0\%$ ), Premium					
Type / WG02	Measuring Range / Readout	Output	Display	Item No.	Price		
	Humidity	Humidity	Temperature	Humidity	Temperature		
<b>VFF-I</b>				<b>I-variant</b>			
VFF-I	0...100% r. H.	–	–	4...20mA	–	1201-6122-0000-100	440,37 €
VFF-I LCD	0...100% r. H.	–	–	4...20mA	–	■ 1201-6122-0200-100	488,93 €
<b>VFF-U</b>				<b>U-variant</b>			
VFF-U	0...100% r. H.	–	–	0-10V	–	1201-6121-0000-100	440,37 €
VFF-U LCD	0...100% r. H.	–	–	0-10V	–	■ 1201-6121-0200-100	488,93 €
<b>VFTF-I</b>				<b>I-variant</b>			
VFTF-I	0...100% r. H.	–35...+75 °C –35...+35 °C 0...+50 °C 0...+80 °C	–	4...20mA	4...20mA	1201-6122-1000-100	444,32 €
VFTF-I LCD	0...100% r. H.	(4x as above)	–	4...20mA	4...20mA	■ 1201-6122-1200-100	493,20 €
<b>VFTF-U</b>				<b>U-variant</b>			
VFTF-U	0...100% r. H.	–35...+75 °C –35...+35 °C 0...+50 °C 0...+80 °C	–	0-10V	0-10V	1201-6121-1000-100	444,32 €
VFTF-U LCD	0...100% r. H.	(4x as above)	–	0-10V	0-10V	■ 1201-6121-1200-100	493,20 €
Optional:	Cable connection with <b>M12 connector</b> according to DIN EN 61076-2-101					on request	



**Room hygro-thermostat, mechanical, one-step**

The mechanical room hygro-thermostat **HYGRASREG® RHT**, a room hygrostat with (bimetal) temperature controller, is used for controlling and monitoring the relative humidity (humidifying and dehumidifying) and the temperature in office and residential rooms, baths, winter gardens, labs, computer rooms, etc. RHT is applied in dust-free, pollutant-free, non-aggressive air.

RHT



**TECHNICAL DATA**

**HYGROSTAT**

Switching capacity: (Contact load)	24...230 V AC > 24 V in dry rooms only according to VDE 0110 Dehumidifying: 5 (0.2) A, min. 100 mA Humidifying: 3 (0.2) A, min. 100 mA
Setting range:	35...100% r. H.
Contact:	2 changeover contact
Sensor element:	plastic fibres
Tolerance:	max. 3% r. H.
Operating difference:	approx. 4% r. H.
Housing temperature:	0...+60°C

<b>FUNCTION</b>	Humidifying: wire terminals 5 and 6 Dehumidifying: wire terminals 5 and 7
-----------------	--

**THERMOSTAT**

Switching capacity:	10 (4) A, 24 / 230V AC
Control range:	+10...+35°C
Contact:	1 changeover contact (potential-free)
Sensor element:	bimetal, with thermal feedback
<b>FUNCTION</b>	Heating: wire terminals 2 and 5 Cooling: wire terminals 3 and 5

Housing:	plastic, material ABS, colour pure white (similar to RAL 9010)
----------	---

Dimensions:	127.5 x 75 x 28.6 mm
-------------	----------------------

Installation:	wall mounting or on in-wall flush box, Ø 55 mm
---------------	---

Electrical connection:	0.14 - 2.5 mm <sup>2</sup> , via terminal screws
------------------------	---

Protection class:	II (according to EN 60 730)
-------------------	-----------------------------

Protection type:	<b>IP 30</b> (according to EN 60 529)
------------------	---------------------------------------

Standards:	CE conformity, EMC directive 2014 / 30 / EU, low-voltage directive 2014 / 35 / EU
------------	---

<b>ACCESSORIES</b>	When mounting indoor room enclosures on in-wall flush boxes with horizontal fixing holes, adapter frame <b>ARA 1.7 E</b> must be included in the order.
--------------------	---

Dimensional drawing

RHT

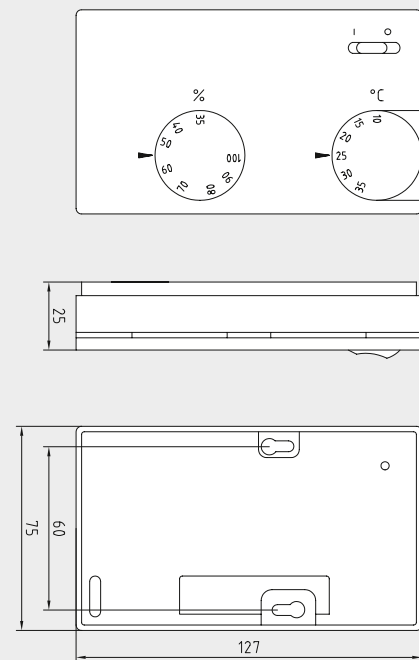

Connecting diagram

RHT

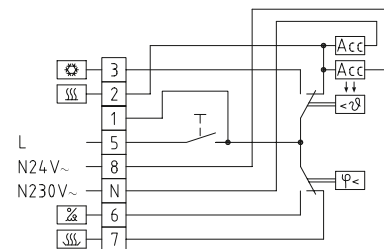

**HYGRASREG® RHT** Room hygro-thermostat

Type/WG02	Setting Range	Steps	Features	Item No.	Price
<b>RHT</b>	Humidity	Temperature		<b>External setting</b>	
RHT-1	35...100% r. H.	+10...+35°C	one-step	main switch	1202-4010-0000-000 <b>158,22 €</b>
<b>ACCESSORIES</b>					
<b>ARA 1,7 E</b>	Adapter frame for in-wall flush boxes			7100-0060-4000-000	<b>6,72 €</b>

Mechanical room hygrostat **HYGRASREG® RH-2** with switching output (with single-pole microswitch as two-position controller with humidity sensor) working without external voltage, with humidity measuring element made of stabilized synthetic gauze, optional with setpoint setter for switchpoint adjustment (external or internal setting) in an elegant housing made of plastic, with snap-on lid, base with 4-hole attachment for installation on vertically or horizontally installed in-wall flush boxes, with predetermined breaking point for on-wall cable entry. RH-2 is used for controlling and monitoring the relative humidity in office and residential rooms, baths, labs, control cabinets, computer rooms, etc., as minimum or maximum hygrostat. It is used in dust-free, pollutant-free, non-aggressive air.

**RH-2**  
(with external setting)



**RH-2U**  
(with internal setting)



TECHNICAL DATA	
Switching capacity: (Contact load)	24 V AC/DC dehumidifying: 5 (0.2) A, min. 100 mA humidifying: 3 (0.2) A, min. 100 mA
Setting range:	25 ... 95 % r. H.
Contact:	1 changeover contact
Sensor element:	plastic fibres
Operating difference:	approx. 4 % r. H.
Tolerance:	max. 3 % r. H.
Housing temperature:	0...+40 °C
Housing:	plastic, material ABS, colour pure white (similar to RAL 9010)
Dimensions:	98 x 98 x 39 mm (Baldur 2, with Potentiometer)
Electrical connection:	0.14 - 2.5 mm <sup>2</sup> , via terminal screws
Installation:	wall mounting or on in-wall flush box Ø 55 mm, base with 4-hole for mounting on vertically or horizontally installed in-wall flush boxes for cable entry from the back, with predetermined breaking point for on-wall cable entry from top / bottom in case of plain on-wall installation
Protection class:	III (according to EN 60 730)
Protection type:	<b>IP 30</b> (according to EN 60 529)
Standards:	CE conformity, EMC directive 2014 / 30 / EU, low-voltage directive 2014 / 35 / EU
<b>FUNCTION</b>	humidifying: wire terminals 1 and 3 dehumidifying: wire terminals 1 and 2

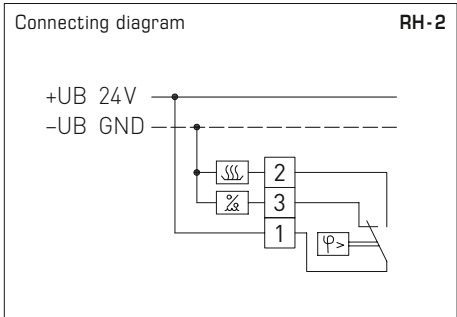
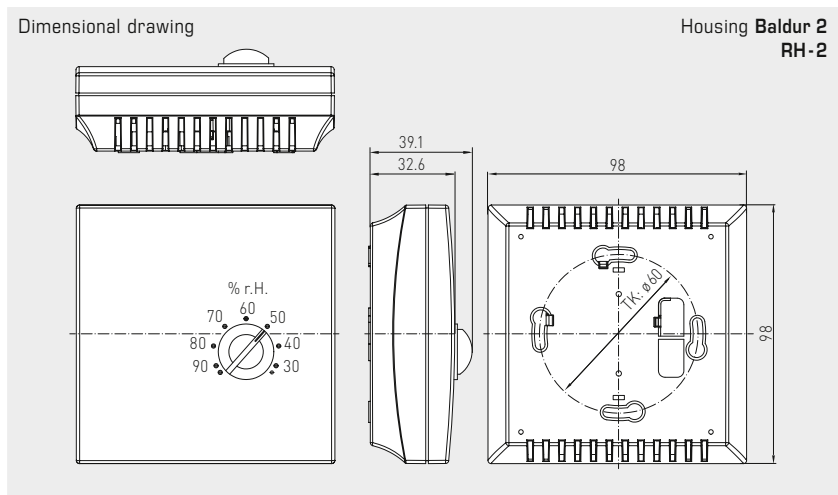

HYGRASREG® RH-2 Room hygrostat, <i>Standard</i>						
Type/WG01	Setting Range Humidity	Hysteresis	Output	Steps	Item No.	Price
<b>RH-2</b>						<b>External setting</b>
RH-2	25...95 % r. H.	approx. 4 % r. H.	1x Changeover contact	one-step	1202-40C0-0010-000	<b>79,05 €</b>
<b>RH-2 U</b>						<b>Internal setting</b>
RH-2 U	25...95 % r. H.	approx. 4 % r. H.	1x Changeover contact	one-step	1202-40C0-0020-000	<b>81,46 €</b>

## Room hygrostats and humidity and temperature sensors ( $\pm 2.0\%$ ), electronic, two-step, with continuous / switching outputs

Electronic room hygrostat and/or room thermostat **HYGRASREG® RHT-30** with one continuous and two switching outputs, adjustable switching thresholds, with / without optional display for indicating ACTUAL humidity and/or ACTUAL temperature (accuracy class  $\pm 2.0\%$  r.H.). The setpoints can be allocated to the relative humidity and/or to the temperature.

It is suitable for regulating and monitoring relative humidity (humidifying and dehumidifying) and/or the temperature (heating and cooling), e.g. in ventilation and air conditioning ducts, laboratories, production facilities, climatic test cabinets, indoor swimming pools, greenhouses, etc., to control humidifying and dehumidifying equipment or heating system control. The measuring transducers are designed for exact humidity/temperature measurement. The RHT-30 uses a digital, long-term stable sensor as a measuring element. It is used in dust-free, unpolluted, non-aggressive air.

### TECHNICAL DATA

Power supply:	24 V AC ( $\pm 20\%$ ), 15...36 V DC
Load resistance:	$R_L > 5 \text{ k}\Omega$
Power consumption:	$< 1,5 \text{ VA} / 24 \text{ V DC}$ , $< 3,5 \text{ VA} / 24 \text{ V AC}$
Sensor:	<b>digital humidity sensor with integrated temperature sensor</b> , low hysteresis, high long-term stability
Setting range:	5...95% r.H. (Humidity) +5...+45°C (Temperature) (switch steps 1 and 2 are separately adjustable)
Operating difference:	<b>Mode 1:</b> both switch steps are freely adjustable (rel. humidity) <b>Mode 2:</b> 5% between both switch steps (rel. humidity) <b>Mode 3:</b> both switch steps freely adjustable (temperature) <b>Mode 4:</b> switch step 1 (temperature), switch step 2 (rel. humidity) (adjustable via DIP switches)
Output:	potential-free changeover contacts (2x changeover contact 24 V, 1A ohmic load, separately adjustable, 1x 0 - 10V)
Deviation, humidity:	typically $\pm 2.0\%$ (20...80% r.H.) at +25°C, otherwise $\pm 3.0\%$
Deviation, temperature:	typically $\pm 0.2 \text{ K}$ at +25°C
Ambient temperature:	storage -35...+85°C; operation -30...+70°C, non-precipitating
Long-term stability:	$\pm 1\%$ per year
Housing:	plastic, material ABS, colour pure white (similar to RAL 9010)
Housing dimensions:	98 x 98 x 35 mm (Baldur 2)
Installation:	wall mounting or on in-wall flush box, $\varnothing 55 \text{ mm}$ , base with 4-hole for mounting on vertically or horizontally installed in-wall flush boxes for cable entry from the back, with predetermined breaking point for on-wall cable entry from top / bottom in case of plain on-wall installation
Protection class:	III (according to EN 60 730)
Protection type:	<b>IP 30</b> (according to EN 60 529)
Electrical connection:	0.14 - 1.5 mm <sup>2</sup> , via terminal screws
Standards:	CE conformity, EMC directive 2014 / 30 / EU
Optional:	two-line <b>display with illumination</b> , cutout approx. 36x15 mm (W x H), for displaying ACTUAL humidity and/or ACTUAL temperature respectively for setpoint adjustment

### FUNCTION

Humidifying/heating:	<b>1st step:</b> wire contacts 11 - 12. If actual humidity falls more than 3% r.H. / 1 K (hysteresis) below switching threshold S1, the changeover contact switches to 11 - 12. <b>2. step:</b> wire contacts 21 - 22. If actual humidity falls more than 3% r.H. / 1 K (hysteresis) below switching threshold S2, the changeover contact switches to 21 - 22. Terminal 2: output relative humidity / temperature
Dehumidifying/cooling:	<b>1st step:</b> wire contacts 11 - 13. When actual humidity exceeds switching threshold S1, the changeover contact switches to 11 - 13. <b>2. step:</b> wire contacts 21 - 23. When actual humidity exceeds switching threshold S2, the changeover contact switches to 21 - 23. Terminal 2: output relative humidity / temperature

The **1st line** of the display shows the **ACTUAL humidity** in % r.H. and the **ACTUAL temperature** in °C. The displays showing the ACTUAL values alternate in a 3-second rhythm. Resolution: 1/10 % r.H. or 1/10 °C.

The **2nd line** shows information about the **switching status of the relay** (as a circuit), and indicates the **switching value** in % r.H. or °C (adjustable via the corresponding set potentiometer). The readouts of the switching thresholds for the first and second relay are displayed alternately at an interval of twenty seconds.

For improved legibility, backlighting is provided.

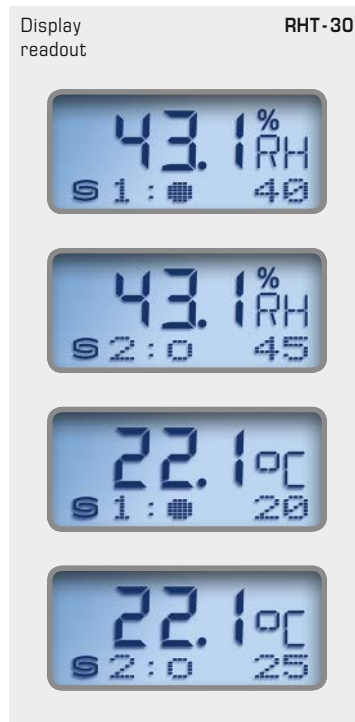

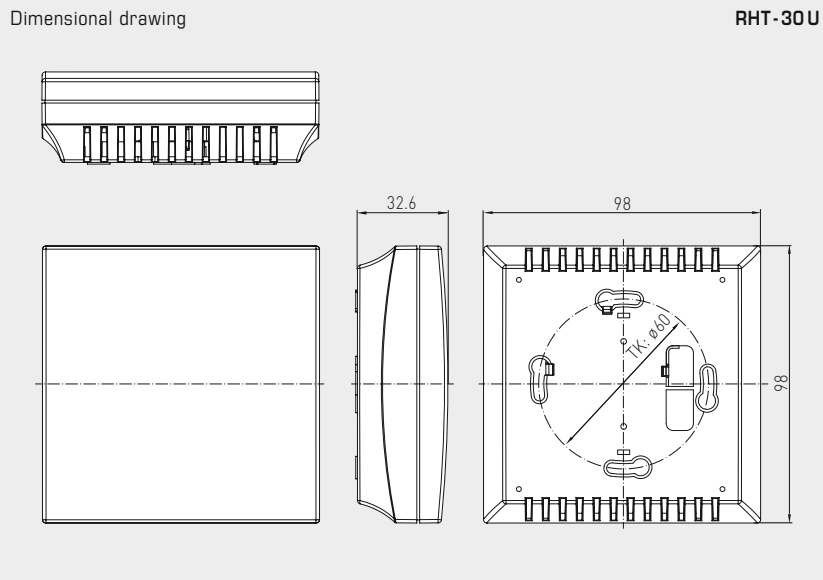

RHT-30U  
with internal setting

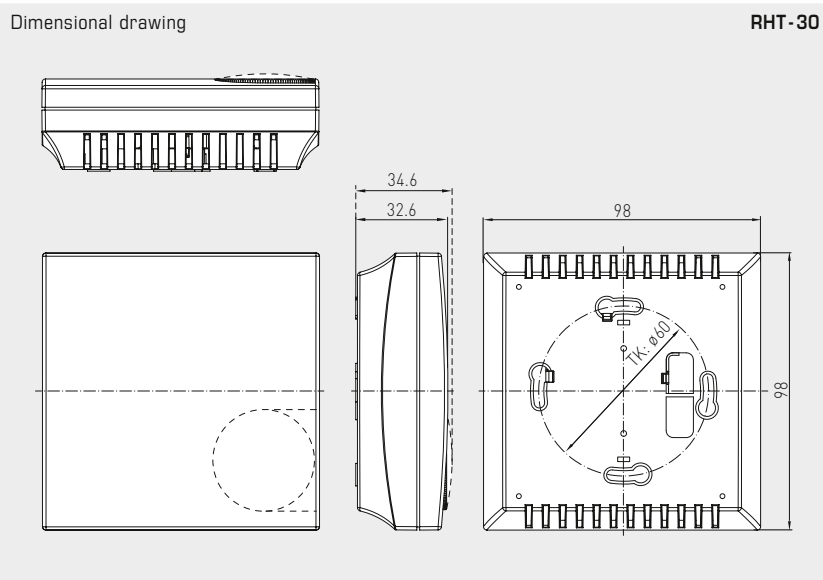

RHT-30



RHT-30  
with display



Room hygrostats and humidity and temperature sensors ( $\pm 2.0\%$ ), electronic, two-step, with continuous / switching outputs

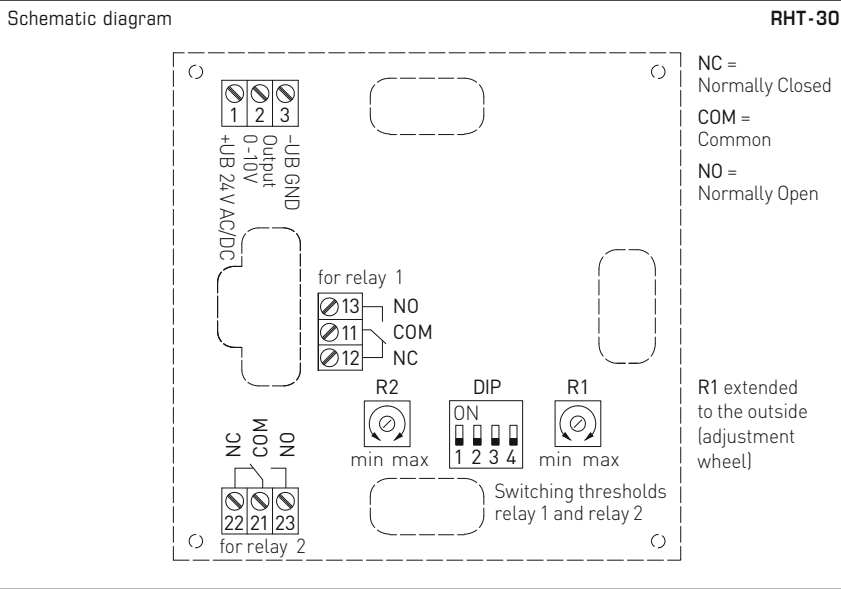

DIP switches	RHT-30	
Function mode	DIP 1	DIP 2
<b>Mode 1</b> (2x 5...95% r.H.) (default)	OFF	OFF
<b>Mode 2</b> (5...95% r.H. + 5% r.H.)	ON	OFF
<b>Mode 3</b> (2x +5...+45°C)	OFF	ON
<b>Mode 4</b> (5...95% r.H./+5...+45°C)	ON	ON
<b>Output</b>	<b>DIP 3</b>	
Temperature	ON	
Relative humidity (default)	OFF	
<b>Backlighting</b>	<b>DIP 4</b>	
activated	ON	
deactivated (default)	OFF	

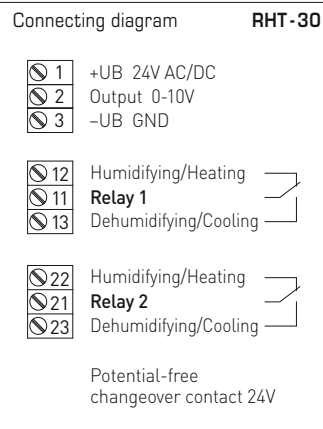

Supply	AC	DC
→ 1	24V~	24V DC
→ 3	0V	GND

12 (A1) →	Relay 1 Breaker contact
11 (W1) →	Relay 1 Changeover contact
13 (B1) →	Relay 1 Normally open contact
22 (A2) →	Relay 2 Breaker contact
21 (W2) →	Relay 2 Changeover contact
23 (B2) →	Relay 2 Normally open contact



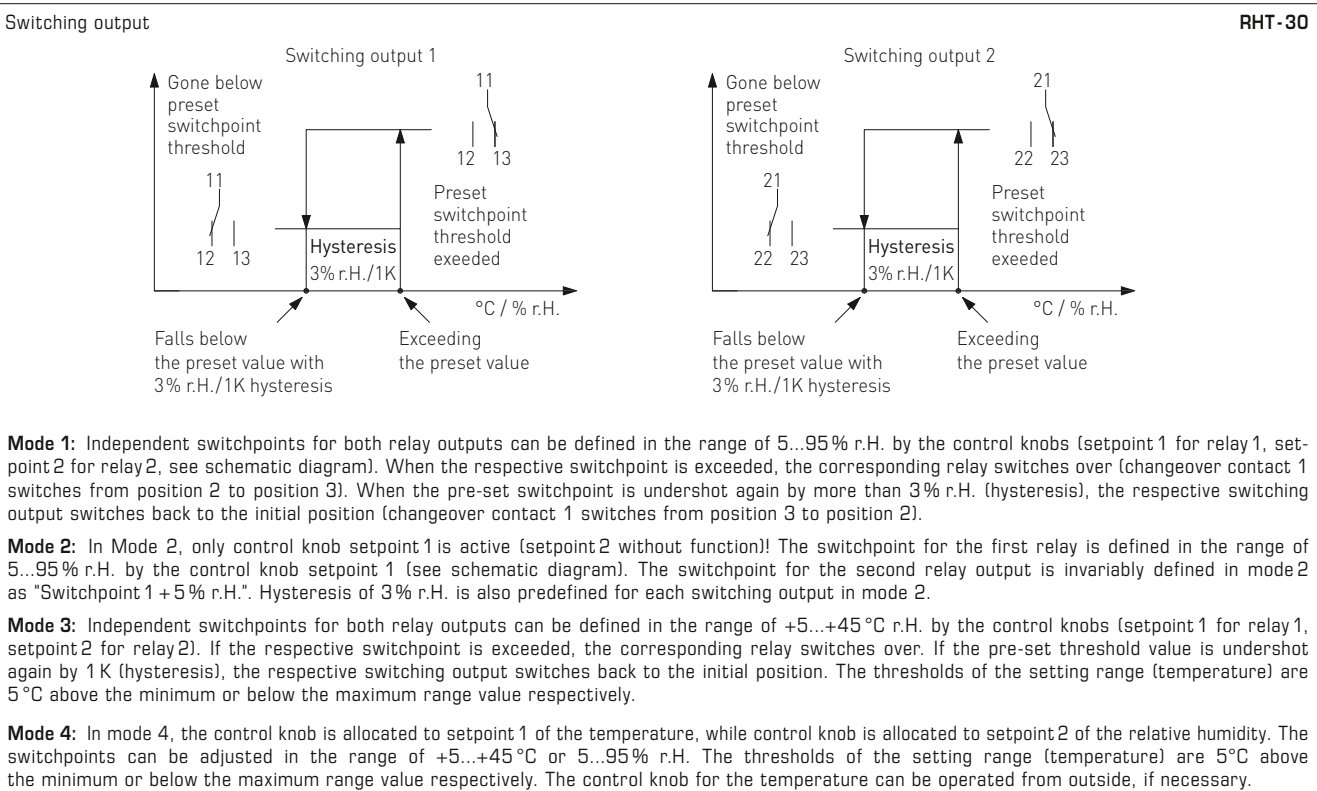



**Humidity table**

MR: 0 ...100% r. H.

% r.H.	U <sub>A</sub> in V	% r.H.	U <sub>A</sub> in V
0	0.0	50	5.0
5	0.5	55	5.5
10	1.0	60	6.0
15	1.5	65	6.5
20	2.0	70	7.0
25	2.5	75	7.5
30	3.0	80	8.0
35	3.5	85	8.5
40	4.0	90	9.0
45	4.5	95	9.5
Continued at the right...		100	10.0

**Temperature table**

MR: 0 ...+50 °C

°C	U <sub>A</sub> in V
0	0.0
5	1.0
10	2.0
15	3.0
20	4.0
25	5.0
30	6.0
35	7.0
40	8.0
45	9.0
50	10.0

RHT-30 with display



**HYGRASREG® RHT - 30** Room hygrostats and humidity and temperature sensors ( $\pm 2.0\%$ )

Type / WG02	Setting Range Humidity    Temperature	Output	Steps	Display	Item No.	Price
<b>RHT-30</b>						<b>External setting</b>
RHT-30W	5...95% r. H.    +5...+45 °C	2x Changeover contact, 1x 0-10V	two-step		1202-4077-1011-200	<b>175,92 €</b>
RHT-30W LCD	5...95% r. H.    +5...+45 °C	2x Changeover contact, 1x 0-10V	two-step	■	1202-4077-1211-200	<b>188,57 €</b>
<b>RHT-30-U</b>						<b>Internal setting</b>
RHT-30W U	5...95% r. H.    +5...+45 °C	2x Changeover contact, 1x 0-10V	two-step		1202-4077-1021-200	<b>173,38 €</b>

**On-wall hygrometers and humidity sensors ( $\pm 2.0\%$ ),  
electronic, one-step,  
with switching outputs**

**AH-40**  
with display and  
metal sinter filter  
(optional)

Electronic hygrometer and humidity sensor **HYGRASREG® AH-40** with one switching output, adjustable switching threshold and display for displaying ACTUAL humidity (accuracy class  $\pm 2.0\%$  r.H.) and for setting the target humidity.

It is suitable for controlling and monitoring the relative air humidity, e.g. in laboratories, production rooms, climatic exposure test cabinets, swimming pools, greenhouses etc., for controlling humidifying and dehumidifying facilities. The measuring transducers are designed for exact detection of humidity. The AH-40 uses a digital, long-term stable sensor as a measuring element for measuring humidity. It is used in dust-free, unpolluted, non-aggressive air.



**TECHNICAL DATA**

Power supply:	24 V AC ( $\pm 20\%$ ) 15...36 V DC
Power consumption:	< 1.1 VA / 24 V DC < 2.2 VA / 24 V AC
Sensors:	<b>digital humidity sensor</b> , small hysteresis, high long-term stability
Sensor protection:	<b>plastic</b> sinter filter, $\varnothing$ 16 mm, L = 35 mm, exchangeable (optional <b>metal</b> sinter filter, $\varnothing$ 16 mm, L = 32 mm)
Setting range:	5...95% r.H.
Output:	potential-free changeover contact (24 V), 1 A ohmic load
Deviation, humidity:	typically $\pm 2.0\%$ (20...80% r.H.) at +25 °C, otherwise $\pm 3.0\%$
Ambient temperature:	storage -35...+85 °C; operation -30...+75 °C, non-precipitating
Long-term stability:	$\pm 1\%$ per year
Housing:	plastic, UV-resistant, material polyamide, 30% glass-globe reinforced, with quick-locking screws (slotted/Phillips head combination), colour traffic white (similar to RAL 9016), housing cover for display is transparent!
Housing dimensions:	72 x 64 x 43.3 mm (Tyr 1 with display)
Electrical connection:	0.14 - 1.5 mm <sup>2</sup> , via terminal screws
Cable connection:	<b>cable gland</b> , plastic (M 16 x 1.5; with strain relief, exchangeable, max. inner diameter 10.4 mm) <b>or</b> <b>M12 connector</b> according to DIN EN 61076-2-101 (optional on request)
Protective tube:	<b>stainless steel V2A</b> (1.4301), $\varnothing$ 16 mm, NL = 55 mm
Prozessanschluss:	by screws
Protection class:	III (according to EN 60 730)
Protection type:	<b>IP65</b> (according to EN 60 529) Housing tested, TÜV SÜD, Report No. 713139052 (Tyr 1)
Standards:	CE conformity, electromagnetic compatibility according to EN 61 326, EMC directive 2014/30/EU
Display:	<b>two-line display with illumination</b> , cutout approx. 36x15 mm (W x H), for displaying actual humidity and for setting the target humidity
Displaying:	The 1 <sup>st</sup> line of the display shows the <b>relative humidity</b> . The 2 <sup>nd</sup> line shows on the left side the information regarding the <b>switching status of the relay</b> (as a circuit), as well as the <b>switching value</b> readout in % r.H. on the right side (adjustable using the set potentiometer).  ○ <b>Circuit, empty</b> = relay in idle state ● <b>Circuit, full</b> = relay energised
<b>FUNCTION</b>	<b>actual humidity &lt; switching value</b> contact 11-12 closed (LED OFF)  <b>actual humidity &gt; switching value</b> contact 11-13 closed (LED ON)





S+S REGELTECHNIK

HYGRASREG® AH-40

On-wall hygrometers and humidity sensors ( $\pm 2.0\%$ ),  
electronic, one-step,  
with switching outputs

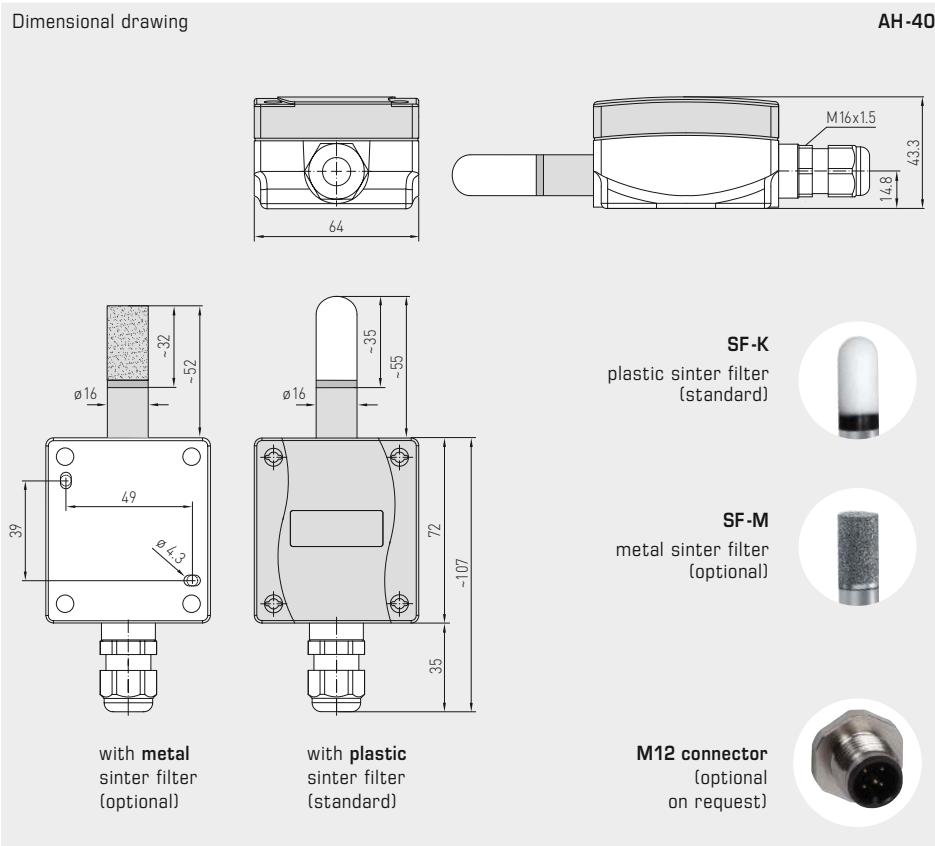

**AH-40**  
with display and  
plastic sinter filter  
(standard)

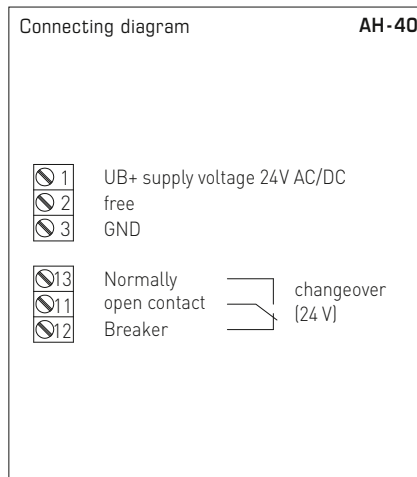
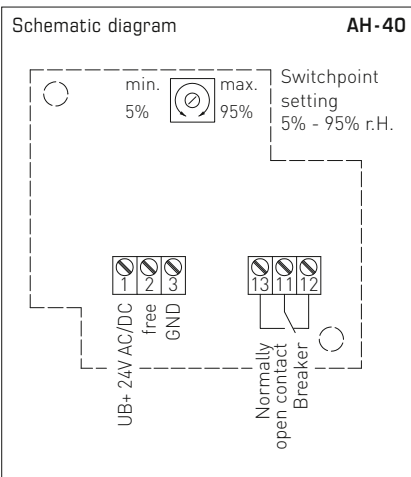

HYGRASREG® AH-40 On-wall hygrometers and humidity sensors ( $\pm 2.0\%$ ), <i>Premium</i>						
Type / WG01	Setting Range Humidity	Output	Steps	Display	Item No.	Price
<b>AH-40-U</b>						
AH-40W LCD	5...95% r.H.	1 x Changeover contact	one-step	■	1202-1065-0221-000	172,77 €
Optional:	Cable connection with <b>M12 connector</b> according to DIN EN 61076-2-101				on request	
ACCESSORIES						
<b>SF-M</b>	<b>Metal sinter filter</b> , $\varnothing 16$ mm, L = 32 mm, exchangeable stainless steel <b>V4A</b> (1.4404)				7000-0050-2200-100	40,31 €

**On-wall hygrometers and  
humidity and temperature sensors ( $\pm 2.0\%$ ),  
electronic, two-step, with multi-range switching  
and continuous/switching output**

Electronic on-wall hygrometer and/or on-wall thermostat **HYGRASREG® AHT-30** with a continuous and two switching outputs, adjustable switching thresholds and display for indicating ACTUAL humidity and/or ACTUAL temperature (accuracy class  $\pm 2.0\%$  r.H.). The setpoints can be allocated to the relative humidity and/or to the temperature.

It is suitable for regulating and monitoring relative humidity (humidifying and dehumidifying) and/or the temperature (heating and cooling), e.g. in laboratories, production facilities, climatic test cabinets, indoor swimming pools, greenhouses, etc., to control humidifying and dehumidifying equipment or heating system control. The measuring transducers are designed for exact humidity/temperature measurement. The AHT-30 uses a digital, long-term stable sensor as a measuring element. It is used in dust-free, unpolluted, non-aggressive air.

#### TECHNICAL DATA

Power supply:	24 V AC / DC ( $\pm 20\%$ )
Power consumption:	< 1,5 VA / 24 V DC, < 3,5 VA / 24 V AC
Sensor:	<b>digital humidity sensor with integrated temperature sensor</b> , low hysteresis, high long-term stability
Sensor protection:	<b>plastic</b> sinter filter, $\varnothing$ 16 mm, L = 35 mm, exchangeable (optional <b>metal</b> sinter filter, $\varnothing$ 16 mm, L = 32 mm)
Setting range:	5...95% r.H. (humidity) <b>Multi-range switching with 4 switchable measuring ranges</b> (see table) -35...+35 °C; -35...+75 °C; 0...+50 °C; 0...+80 °C (temperature) (Switch steps 1 and 2 are separately adjustable)
Operating difference:	<b>Mode 1:</b> both switch steps are freely adjustable (rel. humidity) <b>Mode 2:</b> 5% between both switch steps (rel. humidity) <b>Mode 3:</b> both switch steps freely adjustable (temperature) <b>Mode 4:</b> switch step 1 (temperature), switch step 2 (rel. humidity) (adjustable via DiP switches)
Output:	potential-free changeover contacts (2 x changeover contact 24 V, 1 A ohmic load, separately adjustable, 2x 0 - 10 V for U variant or 4...20 mA for I variant)
Deviation, humidity:	typically $\pm 2.0\%$ (20...80% r. H.) at +25 °C, otherwise $\pm 3.0\%$
Deviation, temperature:	typically $\pm 0.4$ K at +25 °C
Ambient temperature:	storage -35...+85 °C; operation -30...+75 °C, non-precipitating
Long-term stability:	$\pm 1\%$ per year
Housing:	plastic, UV-resistant, material polyamide, 30% glass-globe reinforced, with quick-locking screws (slotted / Phillips head combination), colour traffic white (similar to RAL 9016), housing cover for display is transparent!
Housing dimensions:	126 x 90 x 50 mm (Tyr 2)
Cable connection:	<b>cable gland</b> , plastic (M 16 x 1.5; with strain relief, exchangeable, max. inner diameter 10.4 mm) <b>or</b> <b>M12 connector</b> according to DIN EN 61076-2-101 (optional on request)
Protective tube:	<b>stainless steel V2A</b> (1.4301), $\varnothing$ 16 mm, NL = 55 mm (see dimensional drawing)
Protection class:	III (according to EN 60 730)
Protection type:	<b>IP 65</b> (according to EN 60 529)
Electrical connection:	0.14 - 1.5 mm <sup>2</sup> , via terminal screws
Standards:	CE conformity, EMC directive 2014 / 30 / EU
Display:	three-line <b>display with illumination</b> , cutout approx. 70 x 40 mm (W x H), for displaying ACTUAL humidity and/or ACTUAL temperature or for setpoint adjustment

#### FUNCTION

Humidifying/heating:	<b>1st step:</b> wire contacts 11 - 12. If actual humidity falls more than 3% r.H. / 1 K (hysteresis) below switching threshold S1, the changeover contact switches to 11 - 12. <b>2nd step:</b> wire contacts 21 - 22. If actual humidity falls more than 3% r.H. / 1 K (hysteresis) below switching threshold S2, the changeover contact switches to 21 - 22. Terminal 2: output relative humidity / terminal 3: output temperature
Dehumidifying/cooling:	<b>1st step:</b> wire contacts 11 - 13. When actual humidity exceeds switching threshold S1, the changeover contact switches to 11 - 13. <b>2nd step:</b> wire contacts 21 - 23. When actual humidity exceeds switching threshold S2, the changeover contact switches to 21 - 23. Terminal 2: output relative humidity / terminal 3: output temperature



On-wall hygrometers and humidity and temperature sensors ( $\pm 2.0\%$ ), electronic, two-step, with multi-range switching and continuous/switching output



**Dimensional drawing** **AHT-30**



**SF-K**  
plastic sinter filter  
(standard)



**SF-M**  
metal sinter filter  
(optional)

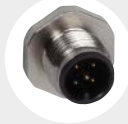

**M12 connector**  
(optional on request)

**AHT-30**  
with display and plastic sinter filter (standard)



**AHT-30**  
with display and metal sinter filter (optional)



**WS-03**

Weather and sun protection hood (optional)



**Display readout**

The **1st line** of the display shows the **ACTUAL humidity** in % r.H. and the **ACTUAL temperature** in °C. The displays showing the ACTUAL values alternate in a 3-second rhythm. The resolution is 1/10 % r.H. or 1/10 °C.

The **3rd line** shows information about the **switching status of relay 1 and 2** (as circuits) on the left, and on the right for the **switching values of relay 1 and 2** in % r.H. or °C (adjustable via the corresponding set potentiometer). The reference to respective measured value (relative humidity or temperature) is determined by the mode selected.

For improved legibility, backlighting is provided.



On-wall hygromats and humidity and temperature sensors ( $\pm 2.0\%$ ), electronic, two-step, with multi-range switching and continuous/switching output

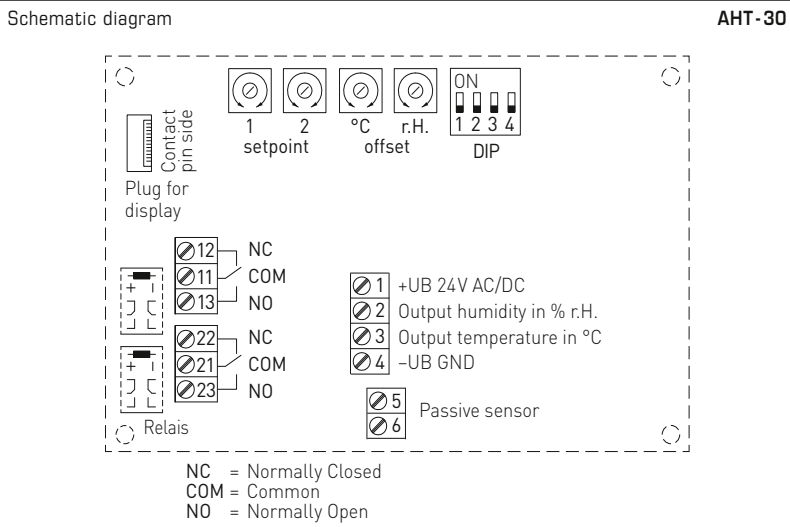

DIP switches	AHT-30	
Function mode	DIP 1	DIP 2
<b>Mode 1</b> (2x 5...95% r.H.) (default)	OFF	OFF
<b>Mode 2</b> (5...95% r.H. + 5% r.H.)	ON	OFF
<b>Mode 3</b> (2x -35...+80 °C)	OFF	ON
<b>Mode 4</b> (5...95% r.H. / -35...+80 °C)	ON	ON
Temperature range	DIP 3	DIP 4
-35...+35 °C	OFF	OFF
0...+80 °C	ON	OFF
0...+50 °C (default)	OFF	ON
-35...+75 °C	ON	ON

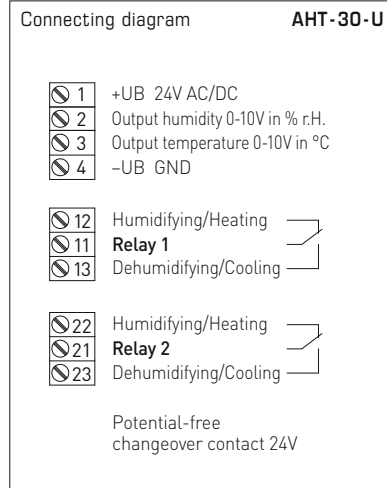
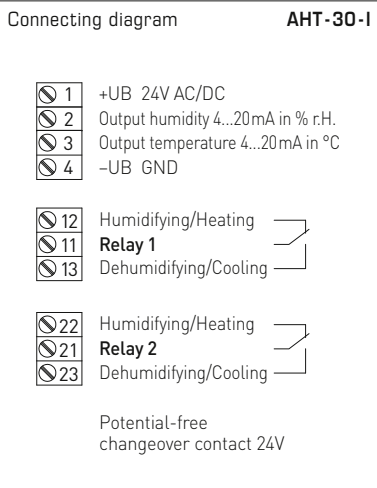

Supply	AC	DC
→ 1	24 V~	24 V DC
→ 4	0V	GND

12 (A1) →	<b>Relay 1</b> Breaker contact
11 (W1) →	<b>Relay 1</b> Changeover contact
13 (B1) →	<b>Relay 1</b> Normally open contact

22 (A2) →	<b>Relay 2</b> Breaker contact
21 (W2) →	<b>Relay 2</b> Changeover contact
23 (B2) →	<b>Relay 2</b> Normally open contact

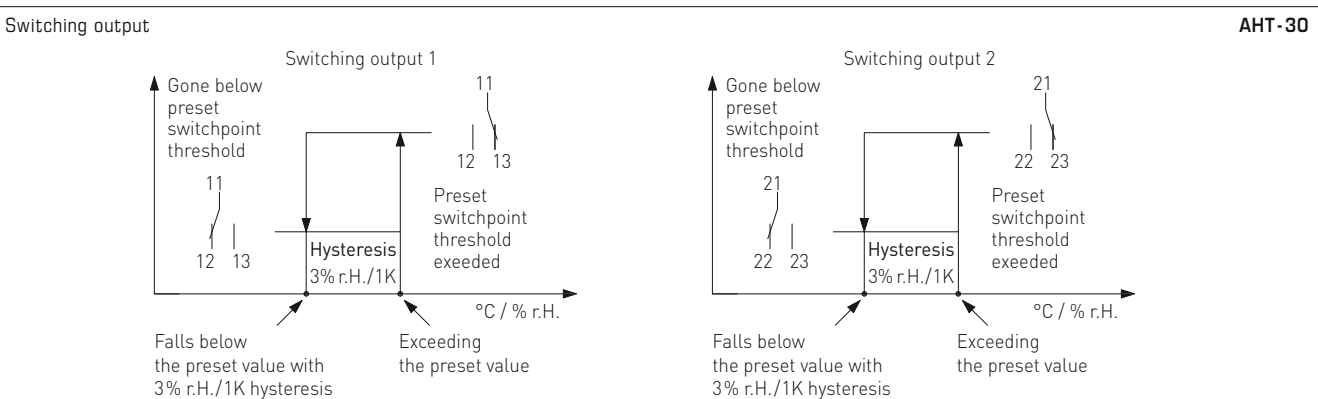

**Mode 1:** Independent switchpoints for both relay outputs can be defined in the range of 5...95% r.H. by the control knobs (setpoint 1 for relay 1, setpoint 2 for relay 2, see schematic diagram). When the respective switchpoint is exceeded, the corresponding relay switches over (changeover contact 1 switches from position 2 to position 3). When the pre-set switchpoint is undershot again by more than 3% r.H. (hysteresis), the respective switching output switches back to the initial position (changeover contact 1 switches from position 3 to position 2).

**Mode 2:** In Mode 2, only control knob setpoint 1 is active (setpoint 2 without function)! The switchpoint for the first relay is defined in the range of 5...95% r.H. by the control knob setpoint 1 (see schematic diagram). The switchpoint for the second relay output is invariably defined in mode 2 as "Switchpoint 1 + 5% r.H.". Hysteresis of 3% r.H. is also predefined for each switching output in mode 2.

**Mode 3:** Independent switchpoints within the temperature range (selectable via DIP switches) for both relay outputs can be defined by the control knobs (setpoint 1 for relay 1, setpoint 2 for relay 2). If the respective switchpoint is exceeded, the corresponding relay switches over. If the pre-set threshold value is undershot again by 1 K (hysteresis), the respective switching output switches back to the initial position. The thresholds of the setting range (temperature) are 5 °C above the minimum or below the maximum range value respectively.

**Mode 4:** In mode 4, the control knob is allocated to setpoint 1 of the temperature, while control knob is allocated to setpoint 2 of the relative humidity. The switchpoints can be set within the temperature range (selectable via DIP switches) or from 5...95% r.H. (humidity). The thresholds of the setting range (temperature) are 5 °C above the minimum or below the maximum range value respectively.



AHT-30 with display



Temperature table  
MR: -35...+75 °C

°C	U <sub>A</sub> in V	I <sub>A</sub> in mA
-35	0.0	4.0
-30	0.5	4.7
-25	0.9	5.5
-20	1.4	6.2
-15	1.8	6.9
-10	2.3	7.6
-5	2.7	8.4
0	3.2	9.1
5	3.6	9.8
10	4.1	10.5
15	4.5	11.3
20	5.0	12.0
25	5.5	12.7
30	5.9	13.5
35	6.4	14.2
40	6.8	14.9
45	7.3	15.6
50	7.7	16.4
55	8.2	17.1
60	8.6	17.8
65	9.1	18.5
70	9.5	19.2
75	10.0	20.0

Temperature table  
MR: -35...+35 °C

°C	U <sub>A</sub> in V	I <sub>A</sub> in mA
-35	0.0	4.0
-30	0.7	5.1
-25	1.4	6.3
-20	2.1	7.4
-15	2.9	8.6
-10	3.6	9.7
-5	4.3	10.9
0	5.0	12.0
5	5.7	13.1
10	6.4	14.3
15	7.1	15.4
20	7.9	16.6
25	8.6	17.7
30	9.3	18.9
35	10.0	20.0

Temperature table  
MR: 0...+50 °C

°C	U <sub>A</sub> in V	I <sub>A</sub> in mA
0	0.0	4.0
5	1.0	5.6
10	2.0	7.2
15	3.0	8.8
20	4.0	10.4
25	5.0	12.0
30	6.0	13.6
35	7.0	15.2
40	8.0	16.8
45	9.0	18.4
50	10.0	20.0

Temperature table  
MR: 0...+80 °C

°C	U <sub>A</sub> in V	I <sub>A</sub> in mA
0	0.0	4.0
5	0.6	5.0
10	1.3	6.0
15	1.9	7.0
20	2.5	8.0
25	3.1	9.0
30	3.8	10.0
35	4.4	11.0
40	5.0	12.0
45	5.6	13.0
50	6.3	14.0
55	6.9	15.0
60	7.5	16.0
65	8.1	17.0
70	8.8	18.0
75	9.4	19.0
80	10.0	20.0

Humidity table  
MR: 0...100 % r. H.

% r.H.	U <sub>A</sub> in V	I <sub>A</sub> in mA
0	0.0	4.0
5	0.5	4.8
10	1.0	5.6
15	1.5	6.4
20	2.0	7.2
25	2.5	8.0
30	3.0	8.8
35	3.5	9.6
40	4.0	10.4
45	4.5	11.2
50	5.0	12.0
55	5.5	12.8
60	6.0	13.6
65	6.5	14.4
70	7.0	15.2
75	7.5	16.0
80	8.0	16.8
85	8.5	17.6
90	9.0	18.4
95	9.5	19.2
100	10.0	20.0

HYGRASREG® AHT-30 On-wall hygrometer and humidity and temperature sensor ( $\pm 2.0\%$ ), <i>Deluxe</i>						
Type / WG02	Setting Range Humidity	Temperature	Output	Steps	Display	Item No. Price
<b>AHT-30-I</b> I-variant						
AHT-30W-I LCD	5...95 % r. H.	-35...+75 °C -35...+35 °C 0...+50 °C 0...+80 °C	2 x changeover contact, 2x 4...20 mA	two-step	■	1202-7127-2421-000 <b>224,59 €</b>
<b>AHT-30-U</b> U-variant						
AHT-30W-U LCD	5...95 % r. H.	-35...+75 °C -35...+35 °C 0...+50 °C 0...+80 °C	2 x changeover contact, 2x 0-10 V	two-step	■	1202-7127-1421-000 <b>224,59 €</b>
Optional:	Cable connection with <b>M12 connector</b> according to DIN EN 61076-2-101					on request
<b>ACCESSORIES</b>						
<b>SF-M</b>	<b>Metal sinter filter</b> , $\varnothing$ 16 mm, L = 32 mm, exchangeable stainless steel <b>V4A</b> (1.4404)					7000-0050-2200-100 <b>40,31 €</b>
<b>WS-03</b>	<b>Weather and sun protection hood</b> , 200 x 180 x 150 mm, stainless steel <b>V2A</b> (1.4301)					7100-0040-6000-000 <b>42,61 €</b>

**Duct hygrostats including mounting flange, mechanical, one-step, with switching output**

Mechanical duct hygrostat **HYGRASREG® KH-10** with switching output as one-step hygrostat. It works without external voltage and is used for controlling and monitoring the relative humidity in ventilation and air conditioning ducts, laboratories, production facilities, climatic test cabinets, indoor swimming pools, greenhouses, etc. to control humidifying and dehumidifying equipment, as minimum guard, or maximum hygrostat. KH-10 is applied in dust-free, pollutant-free, non-aggressive air.

**KH-10-U**  
(with internal setting)



**TECHNICAL DATA**

Switching capacity: (Contact load)	15 (2) A; 24...250 V AC, min. 100 mA > 24 V in dry rooms only according to VDE 0110
Setting range:	35...100 % r. H.
Contact:	dust-proof microswitch as single-pole, potential-free changeover contact (gold-plated optional)
Housing:	plastic, UV-resistant, material polyamide, 30 % glass-globe reinforced, colour traffic white (similar to RAL 9016)
Housing dimensions:	108 x 70 x 73.5 mm (Thor 2)
Cable connection:	<b>cable gland</b> , plastic (M20 x 1.5; with strain relief, exchangeable, inner diameter 8 - 13 mm)
Ambient temperature:	0...+60 °C
Operating difference:	approx. 3...6 % r. H.
Measuring accuracy:	typically ± 4 % r. H.
Controlled medium:	air, unpressurised, non-aggressive
Average temperature coefficient:	0.2 % / K; at +20 °C and 50 % r. H.
Flow rate:	max. 8 m / s
Sensor sleeve:	made of brass nickel-plated, Ø 20 mm, NL = 223 mm
Electrical connection:	0.14 - 1.5 mm <sup>2</sup> , via terminal screws
Protection class:	I (according to EN 60 730)
Protection type:	<b>IP 65</b> (according to EN 60 529)
Standards:	CE conformity, EMC directive 2014 / 30 / EU, low-voltage directive 2014 / 35 / EU

**FUNCTION**

Humidifying:	Wire contacts 1 - 4. Switch points ON/OFF are approx. 2.5 % r. H. above or below the selected value.
Dehumidifying:	Wire contacts 1 - 2. Switch points ON/OFF are approx. 2.5 % r. H. above or below the selected value.

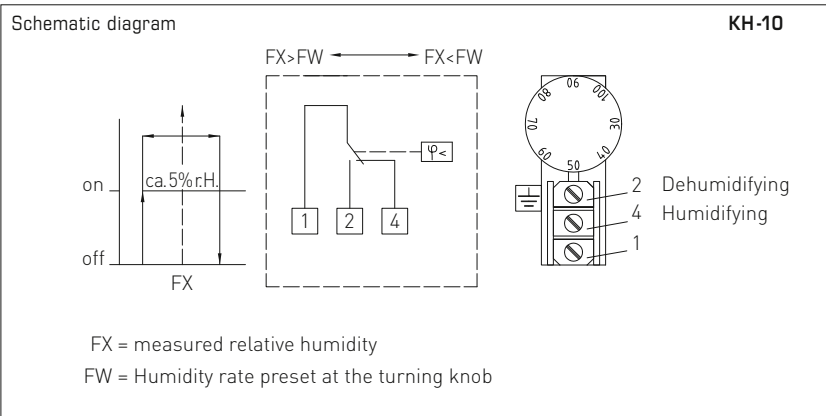

Dimensional drawing **MF-20-K**

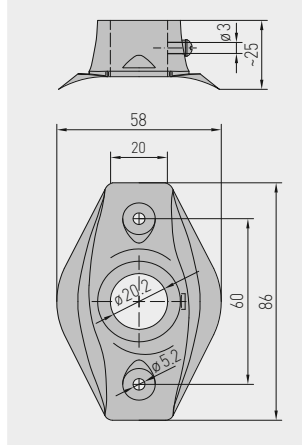



S+S REGELTECHNIK

HYGRASREG® KH-10

Duct hygrostats including mounting flange, mechanical, one-step, with switching output



Dimensional drawing

KH-10

KH-10  
(with external setting)

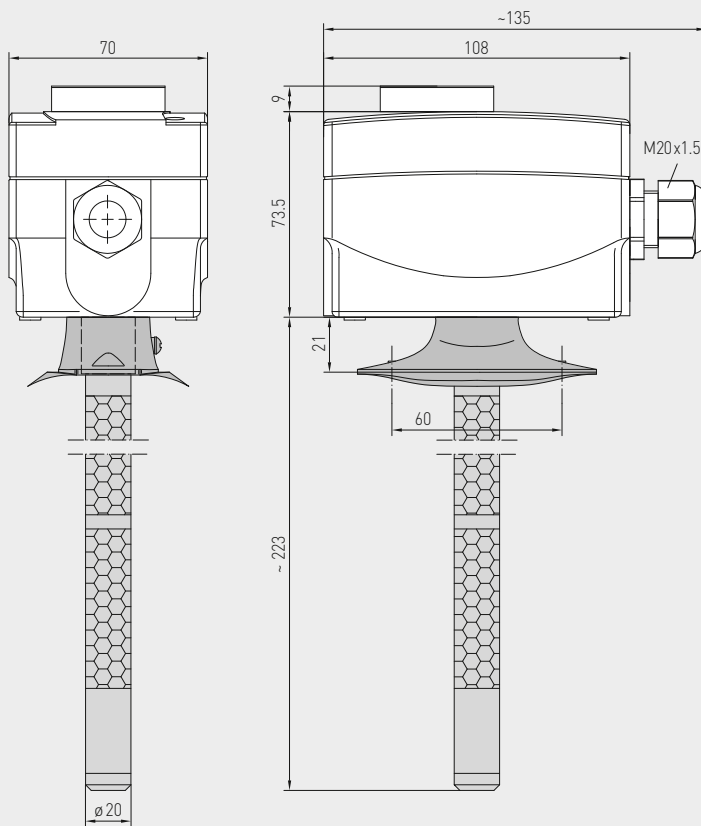

MF-20-K

Mounting flange, plastic



HYGRASREG® KH-10 Duct hygrostats, mechanical, *Standard*

Type / WG01	Setting Range Humidity	Steps	Features	Item No.	Price
				<b>External setting</b>	
<b>KH-10</b>					
KH-10	35...100% r.H.	one-step	–	1202-3012-0010-000	<b>218,44 €</b>
				<b>Internal setting</b>	
<b>KH-10-U</b>					
KH-10 U	35...100% r.H.	one-step	Setpoint setter concealed	1202-3012-0020-000	<b>216,12 €</b>

ACCESSORIES

<b>MF-20-K</b>	<b>Mounting flange</b> for KH, plastic, for duct installation (included in the scope of delivery)			7100-0030-4000-000	<b>9,10 €</b>
<b>WH-20</b>	<b>Wall bracket</b> for KH for on-wall mounting			1200-0010-4000-000	<b>11,88 €</b>

For further information see last chapter!

**Duct hygrostats and humidity sensors ( $\pm 2.0\%$ ), including mounting flange, electronic, one-step, with switching outputs**

Electronic hygrostat and humidity sensor **HYGRASREG® KH-40** with one switching output, adjustable switching threshold and display for displaying ACTUAL humidity (accuracy class  $\pm 2.0\%$  r.H.) and for setting the target humidity. It is suitable for controlling and monitoring the relative air humidity, e.g. in ventilation and air conditioning ducts, laboratories, production rooms, climatic exposure test cabinets, swimming pools, greenhouses etc., for controlling humidifying and dehumidifying facilities. The measuring transducers are designed for exact detection of humidity. The KH-40 uses a digital, long-term stable sensor as a measuring element for measuring humidity. It is used in dust-free, unpolluted, non-aggressive air.

**SF-K**  
Plastic sinter filter (standard)



**SF-M**  
Metal sinter filter (optional)



**MFT-20-K**  
Mounting flange, plastic



Dimensional drawing **MFT-20-K**

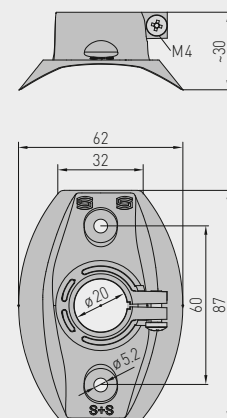

Display standard **KH-40**



**TECHNICAL DATA**

Power supply:	24 V AC ( $\pm 20\%$ ) and 15...36 V DC
Power consumption:	< 1.1 VA / 24 V DC; < 2.2 VA / 24 V AC
Sensors:	<b>digital humidity sensor</b> , small hysteresis, high long-term stability
Sensor protection:	<b>plastic sinter filter</b> , $\varnothing$ 16 mm, L = 35 mm, exchangeable (optional <b>metal sinter filter</b> , $\varnothing$ 16 mm, L = 32 mm)
Setting range:	5...95 % r. H.
Output:	potential-free changeover contact (24 V), 1 A ohmic load
Deviation, humidity:	typically $\pm 2.0\%$ (20...80 % r. H.) at +25 °C, otherwise $\pm 3.0\%$
Ambient temperature:	storage -35...+85 °C; operation -30...+75 °C, non-precipitating
Long-term stability:	$\pm 1\%$ per year
Housing:	plastic, UV-resistant, material polyamide, 30 % glass-globe reinforced, with quick-locking screws (slotted / Phillips head combination), colour traffic white (similar to RAL 9016), housing cover for display is transparent!
Housing dimensions:	72 x 64 x 43.3 mm (Tyr 1 with display)
Cable connection:	<b>cable gland</b> , plastic (M 16 x 1.5; with strain relief, exchangeable, max. inner diameter 10.4 mm) <b>or</b> <b>M12 connector</b> according to DIN EN 61076-2-101 (on request)
Protective tube:	<b>PLEUROFORM™</b> , material polyamide (PA6), with torsion protection, $\varnothing$ 20 mm, NL = 235 mm, $v_{max} = 30$ m/s (air) (on request, optional <b>stainless steel V2A</b> (1.4301), $\varnothing$ 16 mm)
Process connection:	by mounting flange, plastic (included in the scope of delivery)
Electrical connection:	0.14 - 1.5 mm <sup>2</sup> , via terminal screws
Protection class:	III (according to EN 60 730)
Protection type:	<b>IP65</b> (according to EN 60 529) in the built-in state Housing tested, TÜV SÜD, Report No. 713139052 (Tyr 1)
Standards:	CE conformity, electromagnetic compatibility according to EN 61 326, EMC directive 2014 / 30 / EU
Display:	two-line <b>display with illumination</b> , cutout approx. 36 x 15 mm (W x H), for displaying actual humidit and for setting the target humidity
Displaying:	The 1st line of the display shows the <b>relative humidity</b> . The 2nd line shows on the left side the information regarding the <b>switching status of the relay</b> (as a circuit), as well as the <b>switching value</b> readout in % r.H. on the right side (adjustable using the set potentiometer).  ○ <b>Circuit, empty</b> = relay in idle state ● <b>Circuit, full</b> = relay energised
<b>FUNCTION</b>	<b>actual humidity &lt; switching value</b> contact 11-12 closed (LED OFF)  <b>actual humidity &gt; switching value</b> contact 11-13 closed (LED ON)





S+S REGELTECHNIK

HYGRASREG® KH-40

Duct hygrostats and humidity sensors ( $\pm 2.0\%$ ), including mounting flange, electronic, one-step, with switching outputs

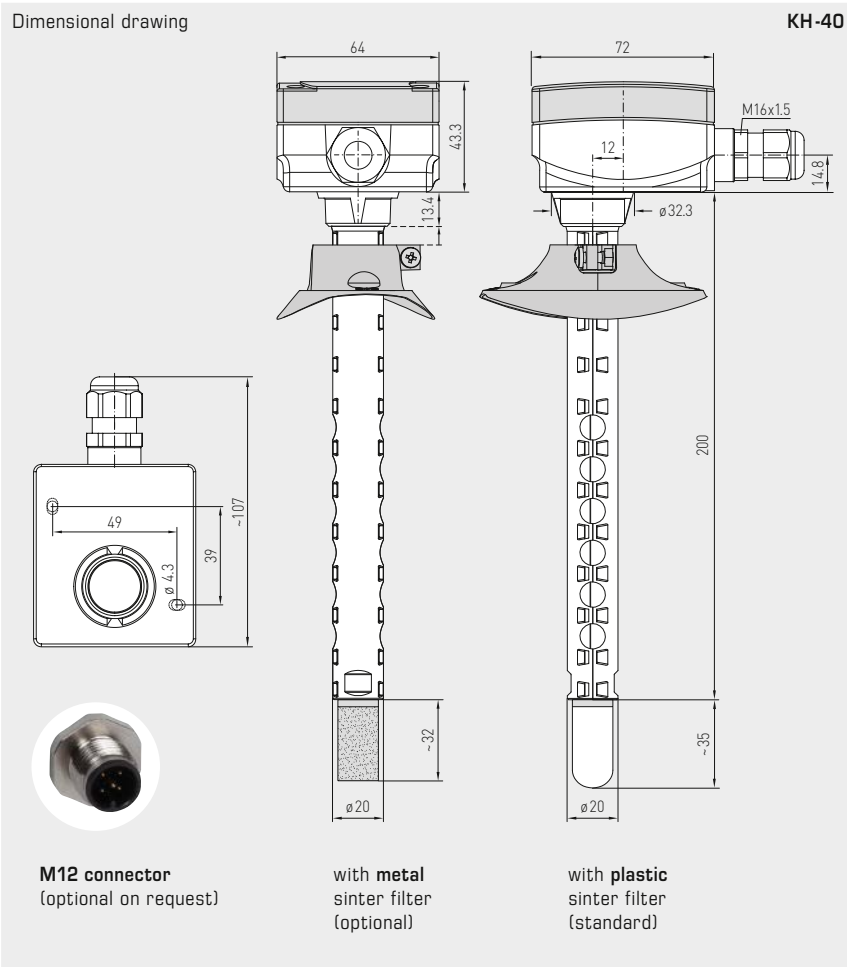

KH-40 with display and plastic sinter filter (standard)

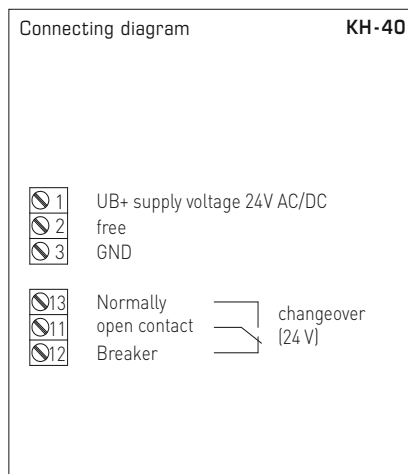
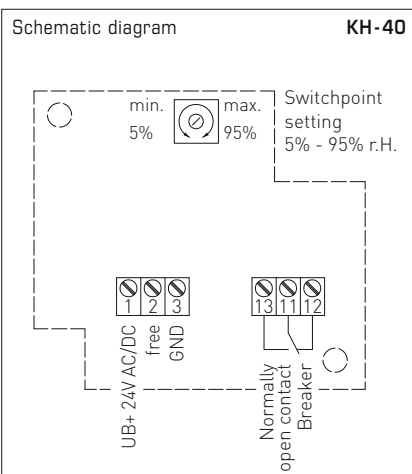

HYGRASREG® KH-40 Duct hygrostats and humidity sensors ( $\pm 2.0\%$ ), Premium						
Type/WG01	Setting Range Humidity	Output	Steps	Display	Item No.	Price
<b>KH-40</b>						
KH-40W LCD	5...95% r.H.	1 x Changeover contact	one-step	■	1202-3065-0221-000	173,91 €
Optional:	Cable connection with M12 connector according to DIN EN 61076-2-101				on request	
ACCESSORIES						
<b>SF-M</b>	Metal sinter filter, $\varnothing$ 16 mm, L = 32 mm, exchangeable stainless steel V4A (1.4404)				7000-0050-2200-100	40,31 €

**Duct hygrostats and humidity and temperature sensors ( $\pm 2.0\%$ ), incl. mounting flange, electronic, two-step, with multi-range switching and continuous/switching output**

Electronic duct hygrostat and/or duct thermostat **HYGRASREG® KHT-30** with a continuous and two switching outputs, adjustable switching thresholds and display for indicating ACTUAL humidity and/or ACTUAL temperature (accuracy class  $\pm 2.0\%$  r.H.). The setpoints can be allocated to the relative humidity and/or to the temperature.

It is suitable for regulating and monitoring relative humidity (humidifying and dehumidifying) and/or the temperature (heating and cooling), e.g. in ventilation and air conditioning ducts, laboratories, production facilities, climatic test cabinets, indoor swimming pools, greenhouses, etc., to control humidifying and dehumidifying equipment or heating system control. The measuring transducers are designed for exact humidity/temperature measurement. The KHT-30 uses a digital, long-term stable sensor as a measuring element. It is used in dust-free, unpolluted, non-aggressive air.

#### TECHNICAL DATA

Power supply:	24 V AC/DC ( $\pm 20\%$ )
Power consumption:	< 1,5 VA / 24 V DC, < 3,5 VA / 24 V AC
Sensor:	<b>digital humidity sensor with integrated temperature sensor</b> , low hysteresis, high long-term stability
Sensor protection:	<b>plastic</b> sinter filter, $\varnothing$ 16 mm, L = 35 mm, exchangeable (optional <b>metal</b> sinter filter, $\varnothing$ 16 mm, L = 32 mm)
Setting range:	5...95 % r.H. (humidity) <b>Multi-range switching with 4 switchable measuring ranges</b> (see table) -35...+35 °C; -35...+75 °C; 0...+50 °C; 0...+80 °C (temperature) (Switch steps 1 and 2 are separately adjustable)
Operating difference:	<b>Mode 1:</b> both switch steps are freely adjustable (rel. humidity) <b>Mode 2:</b> 5 % between both switch steps (rel. humidity) <b>Mode 3:</b> both switch steps freely adjustable (temperature) <b>Mode 4:</b> switch step 1 (temperature), switch step 2 (rel. humidity) (adjustable via DIP switches)
Output:	potential-free changeover contacts (2x changeover contact 24 V, 1A ohmic load, separately adjustable, 2x 0-10V for U variant or 4...20mA for I variant)
Deviation, humidity:	typically $\pm 2.0\%$ (20...80 % r.H.) at +25 °C, otherwise $\pm 3.0\%$
Deviation, temperature:	typically $\pm 0.2\text{K}$ at +25 °C
Ambient temperature:	storage -35...+85 °C; operation -30...+75 °C, non-precipitating
Long-term stability:	$\pm 1\%$ per year
Housing:	plastic, UV-resistant, material polyamide, 30 % glass-globe reinforced, with quick-locking screws (slotted / Phillips head combination), colour traffic white (similar to RAL 9016), housing cover for display is transparent!
Housing dimensions:	126 x 90 x 50 mm (Ty2)
Cable connection:	<b>cable gland</b> , plastic (M 16 x 1.5; with strain relief, exchangeable, max. inner diameter 10.4 mm) <b>or</b> <b>M12 connector</b> according to DIN EN 61076-2-101 (optional on request)
Protective tube:	<b>PLEUROFORM™</b> , material polyamide (PA6), with torsion protection, $\varnothing$ 20 mm, NL = 235 mm, $v_{\text{max}} = 30$ m/s (air) (optional available on request <b>stainless steel V2A</b> (1.4301), $\varnothing$ 16 mm)
Protection class:	III (according to EN 60 730)
Protection type:	<b>IP 65</b> (according to EN 60 529)
Electrical connection:	0.14 - 1.5 mm <sup>2</sup> , via terminal screws
Standards:	CE conformity, EMC directive 2014/30/EU
Display:	three-line <b>display with illumination</b> , cutout approx. 70 x 40 mm (W x H), for displaying ACTUAL humidity and/or ACTUAL temperature or for setpoint adjustment

#### FUNCTION

Humidifying/heating:	<b>1st step:</b> wire contacts 11 - 12. If actual humidity falls more than 3 % r.H. / 1 K (hysteresis) below switching threshold S1, the changeover contact switches to 11 - 12. <b>2nd step:</b> wire contacts 21 - 22. If actual humidity falls more than 3 % r.H. / 1 K (hysteresis) below switching threshold S2, the changeover contact switches to 21 - 22. Terminal 2: output relative humidity / terminal 3: output temperature
Dehumidifying/cooling:	<b>1st step:</b> wire contacts 11 - 13. When actual humidity exceeds switching threshold S1, the changeover contact switches to 11 - 13. <b>2nd step:</b> wire contacts 21 - 23. When actual humidity exceeds switching threshold S2, the changeover contact switches to 21 - 23. Terminal 2: output relative humidity / terminal 3: output temperature



Duct hygrostats and humidity and temperature sensors ( $\pm 2.0\%$ ), incl. mounting flange, electronic, two-step, with multi-range switching and continuous/switching output



Dimensional drawing KHT-30

**SF-K**  
plastic sinter filter  
(standard)

**SF-M**  
metal sinter filter  
(optional)

**M12 connector**  
(optional on request)

**KHT-30**  
with display and plastic sinter filter (standard)



**KHT-30**  
with display and metal sinter filter (optional)



Dimensional drawing MFT-20-K

**MFT-20-K**  
Mounting flange, plastic



**Display readout**

The **1st line** of the display shows the **ACTUAL humidity** in % r.H. and the **ACTUAL temperature** in °C. The displays showing the ACTUAL values alternate in a 3-second rhythm. The resolution is 1/10 % r.H. or 1/10 °C.

The **3rd line** shows information about the **switching status of relay 1 and 2** (as circuits) on the left, and on the right for the **switching values of relay 1 and 2** in % r.H. or °C (adjustable via the corresponding set potentiometer). The reference to respective measured value (relative humidity or temperature) is determined by the mode selected.

For improved legibility, backlighting is provided.

Duct hygromats and humidity and temperature sensors ( $\pm 2.0\%$ ), incl. mounting flange, electronic, two-step, with multi-range switching and continuous/switching output

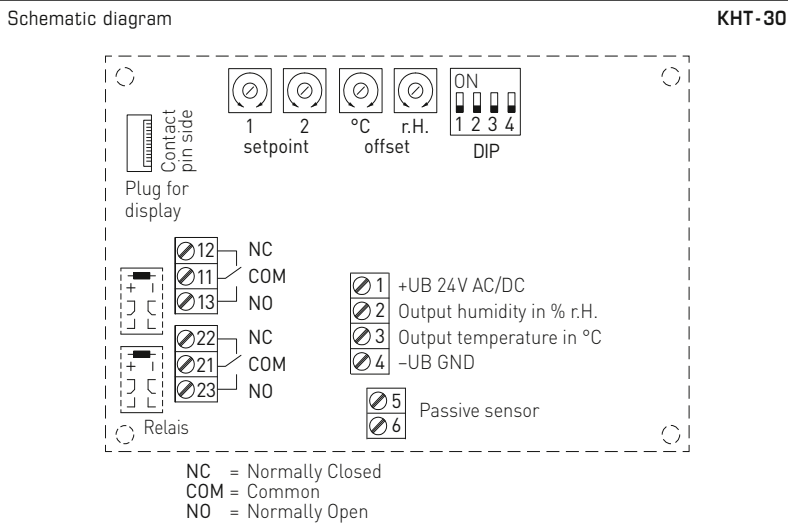

DIP switches	KHT-30	
Function mode	DIP 1	DIP 2
<b>Mode 1</b> (2x 5...95% r.H.) (default)	OFF	OFF
<b>Mode 2</b> (5...95% r.H. + 5% r.H.)	ON	OFF
<b>Mode 3</b> (2x -35...+80 °C)	OFF	ON
<b>Mode 4</b> (5...95% r.H. / -35...+80 °C)	ON	ON
Temperature range	DIP 3	DIP 4
-35...+35 °C	OFF	OFF
0...+80 °C	ON	OFF
0...+50 °C (default)	OFF	ON
-35...+75 °C	ON	ON

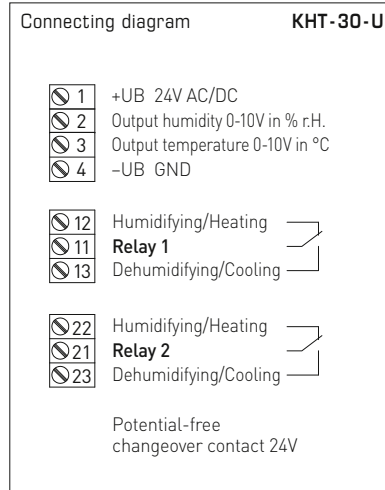
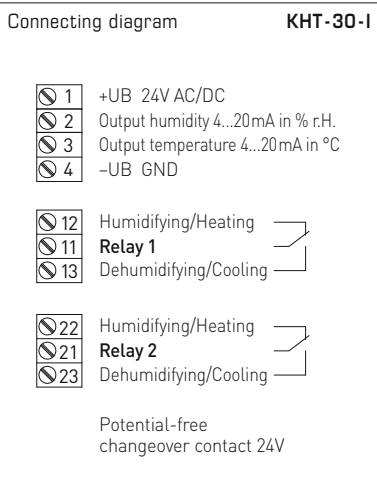

Supply	AC	DC
→ 1	24 V~	24 V DC
→ 4	0V	GND

12 (A1) →	Relay 1 Breaker contact
11 (W1) →	Relay 1 Changeover contact
13 (B1) →	Relay 1 Normally open contact

22 (A2) →	Relay 2 Breaker contact
21 (W2) →	Relay 2 Changeover contact
23 (B2) →	Relay 2 Normally open contact

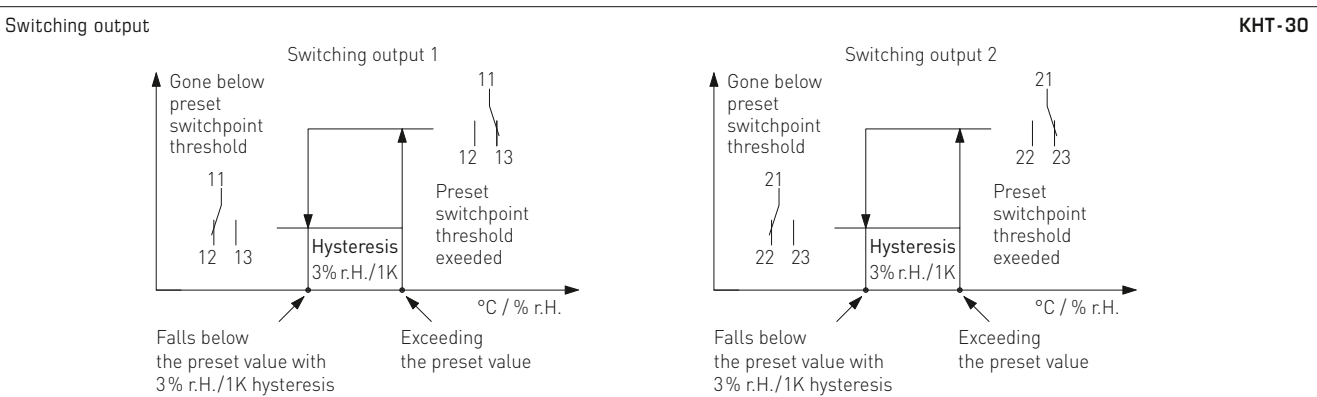

**Mode 1:** Independent switchpoints for both relay outputs can be defined in the range of 5...95% r.H. by the control knobs (setpoint 1 for relay 1, setpoint 2 for relay 2, see schematic diagram). When the respective switchpoint is exceeded, the corresponding relay switches over (changeover contact 1 switches from position 2 to position 3). When the pre-set switchpoint is undershot again by more than 3% r.H. (hysteresis), the respective switching output switches back to the initial position (changeover contact 1 switches from position 3 to position 2).

**Mode 2:** In Mode 2, only control knob setpoint 1 is active (setpoint 2 without function)! The switchpoint for the first relay is defined in the range of 5...95% r.H. by the control knob setpoint 1 (see schematic diagram). The switchpoint for the second relay output is invariably defined in mode 2 as "Switchpoint 1 + 5% r.H.". Hysteresis of 3% r.H. is also predefined for each switching output in mode 2.

**Mode 3:** Independent switchpoints within the temperature range (selectable via DIP switches) for both relay outputs can be defined by the control knobs (setpoint 1 for relay 1, setpoint 2 for relay 2). If the respective switchpoint is exceeded, the corresponding relay switches over. If the pre-set threshold value is undershot again by 1 K (hysteresis), the respective switching output switches back to the initial position. The thresholds of the setting range (temperature) are 5 °C above the minimum or below the maximum range value respectively.

**Mode 4:** In mode 4, the control knob is allocated to setpoint 1 of the temperature, while control knob is allocated to setpoint 2 of the relative humidity. The switchpoints can be set within the temperature range (selectable via DIP switches) or from 5...95% r.H. (humidity). The thresholds of the setting range (temperature) are 5 °C above the minimum or below the maximum range value respectively.



Duct hygromats and humidity and temperature sensors ( $\pm 2.0\%$ ), incl. mounting flange, electronic, two-step, with multi-range switching and continuous/switching output



KHT-30 with display

Temperature table  
MR: -35...+75 °C

°C	U <sub>A</sub> in V	I <sub>A</sub> in mA
-35	0.0	4.0
-30	0.5	4.7
-25	0.9	5.5
-20	1.4	6.2
-15	1.8	6.9
-10	2.3	7.6
-5	2.7	8.4
0	3.2	9.1
5	3.6	9.8
10	4.1	10.5
15	4.5	11.3
20	5.0	12.0
25	5.5	12.7
30	5.9	13.5
35	6.4	14.2
40	6.8	14.9
45	7.3	15.6
50	7.7	16.4
55	8.2	17.1
60	8.6	17.8
65	9.1	18.5
70	9.5	19.2
75	10.0	20.0

Temperature table  
MR: -35...+35 °C

°C	U <sub>A</sub> in V	I <sub>A</sub> in mA
-35	0.0	4.0
-30	0.7	5.1
-25	1.4	6.3
-20	2.1	7.4
-15	2.9	8.6
-10	3.6	9.7
-5	4.3	10.9
0	5.0	12.0
5	5.7	13.1
10	6.4	14.3
15	7.1	15.4
20	7.9	16.6
25	8.6	17.7
30	9.3	18.9
35	10.0	20.0

Temperature table  
MR: 0...+50 °C

°C	U <sub>A</sub> in V	I <sub>A</sub> in mA
0	0.0	4.0
5	1.0	5.6
10	2.0	7.2
15	3.0	8.8
20	4.0	10.4
25	5.0	12.0
30	6.0	13.6
35	7.0	15.2
40	8.0	16.8
45	9.0	18.4
50	10.0	20.0

Temperature table  
MR: 0...+80 °C

°C	U <sub>A</sub> in V	I <sub>A</sub> in mA
0	0.0	4.0
5	0.6	5.0
10	1.3	6.0
15	1.9	7.0
20	2.5	8.0
25	3.1	9.0
30	3.8	10.0
35	4.4	11.0
40	5.0	12.0
45	5.6	13.0
50	6.3	14.0
55	6.9	15.0
60	7.5	16.0
65	8.1	17.0
70	8.8	18.0
75	9.4	19.0
80	10.0	20.0

Humidity table  
MR: 0...100 % r. H.

% r.H.	U <sub>A</sub> in V	I <sub>A</sub> in mA
0	0.0	4.0
5	0.5	4.8
10	1.0	5.6
15	1.5	6.4
20	2.0	7.2
25	2.5	8.0
30	3.0	8.8
35	3.5	9.6
40	4.0	10.4
45	4.5	11.2
50	5.0	12.0
55	5.5	12.8
60	6.0	13.6
65	6.5	14.4
70	7.0	15.2
75	7.5	16.0
80	8.0	16.8
85	8.5	17.6
90	9.0	18.4
95	9.5	19.2
100	10.0	20.0

HYGRASREG® KHT - 30 Duct hygromat and humidity and temperature sensor ( $\pm 2.0\%$ ), <i>Deluxe</i>						
Type / WG02	Setting Range	Output	Steps	Display	Item No.	Price
	Humidity	Temperature				
<b>KHT-30-I</b> I-variant						
KHT-30W-I LCD	5...95% r. H.	-35...+75 °C -35...+35 °C 0...+50 °C 0...+80 °C	2 x changeover contact, 2x 4...20mA	two-step	■ 1202-8127-2421-000	224,59 €
<b>KHT-30-U</b> U-variant						
KHT-30W-U LCD	5...95% r. H.	-35...+75 °C -35...+35 °C 0...+50 °C 0...+80 °C	2 x changeover contact, 2x 0-10V	two-step	■ 1202-8127-1421-000	224,59 €
Optional:	Cable connection with <b>M12 connector</b> according to DIN EN 61076-2-101				on request	
<b>ACCESSORIES</b>						
<b>SF-M</b>	<b>Metal</b> sinter filter, $\varnothing$ 16 mm, L = 32 mm, exchangeable stainless steel <b>V4A</b> (1.4404)				7000-0050-2200-100	40,31 €



**Condensation control switches**  
including strap / with detached sensor head,  
with switching output

**Patented quality product**  
(pro-dynamic cross convection patent no. DE 10 2012 015 726.6)

The condensation control switch **HYGRASREG® KW** with housing made from impact-resistant plastic with quick-locking screws or the cost-effective **HYGRASREG® KW-SD** with snap-on lid is installed on cooling ceilings, on cooling/cold-water piping or on cooled surfaces and is designed to prevent the formation of condensation.

It reliably detects formation of dew by means of its humidity and temperature sensor (no conductivity measurement) and, thanks to its measuring method, **pro-dynamic cross convection**, yields an exact measurement result (with LED status indicator).

Dew point temperature is that temperature at which air reaches the state of saturation and water vapour starts to condensate. The KW condensation control switch can be operated as a monitor on cooling ceilings or pipes so that the switching output is activated when dew builds up on the cooling ceilings of the property to be monitored and e.g. a heating system is started, or other actuators are initiated.

**TECHNICAL DATA**

Power supply:	24 V AC (±20%) and 15...36 V DC
Power consumption:	< 1.1 VA / 24 V DC; < 2.2 VA / 24 V AC
Switchpoint:	approx. 93% r.H. (permanently set)
Output:	potential-free changeover contact (24 V), 1 A ohmic load
Sensor protection:	membrane filter
Medium:	clean air and non-aggressive, non-combustible gases
Housing:	plastic, UV-resistant, material polyamide, 30% glass-globe reinforced, colour traffic white (similar to RAL 9016), housing cover is transparent! <b>KW-xx with quick-locking screws</b> (slotted / Phillips head combination), <b>KW-xx-SD with snap-on lid,</b>
Housing dimensions:	72 x 64 x 43.3 mm (Tyr 1 / Tyr 01)
Cable connection:	<b>cable gland</b> , plastic (M 16 x 1.5; with strain relief, exchangeable, inner diameter 10.4 mm) <b>or</b> <b>M12 connector</b> according to DIN EN 61076-2-101 (optional on request)
Electrical connection:	0.14 - 1.5 mm <sup>2</sup> , via terminal screws
Process connection:	endless strap with metal tightener, 300 mm, for pipes up to 3" diameter (included in the scope of delivery)
Mounting:	The mounting position should be selected so that no condensate can enter the sensor system in the event that condensation forms! <b>KW / KW-SD</b> with strap for direct mounting on pipes or for direct mounting on flat surfaces (e.g. walls, ceilings) <b>KW-external / KW-SD-external</b> with detached sensor head (cable length KL = 1.5 m) for mounting on pipes
Protection class:	III (according to EN 60 730)
Protection type:	<b>KW-xx IP 65</b> (according to EN 60 529) Housing tested, TÜV SÜD, Report No. 713139052 (Tyr 1) <b>KW-SD-xx IP 54</b> (according to EN 60 529) Housing tested, TÜV SÜD, Report No. 713160960A (Tyr 01)
Standards:	CE-conformity, electromagnetic compatibility according to EN 61 326, EMC Directive 2014 / 30 / EU

**FUNCTION**

The relay output is triggered (contact 13-11 closed) if the **switchpoint (93% r.H.)** is not reached and opens (contact 12-11 closed) in the event of a fault (power failure, condensation).



**LED short pulses =**  
relay active → switchpoint not reached  
ACTUAL humidity < 93% r.H. (no condensation)



**LED long pulses =**  
relay inactive → switchpoint exceeded  
ACTUAL humidity > 93% r.H. (condensation)

**KW-SD**  
with snap-on lid  
(IP 54)



**KW-SD-extern**  
with snap-on lid  
(IP 54)





S+S REGELTECHNIK

HYGRASREG® KW  
HYGRASREG® KW-SD

Condensation control switches  
including strap/with detached sensor head,  
with switching output



Dimensional drawing **KW  
KW-SD**

**M12 connector**  
(optional on request)

**KW**  
with quick-locking screws  
(IP 65)



Dimensional drawing **KW-external  
KW-SD-external**

**M12 connector**  
(optional on request)

**KW-extern**  
with quick-locking screws  
(IP 65)



Condensation control switches  
including strap / with detached sensor head,  
with switching output

**KW**  
pro-dynamic  
cross convection

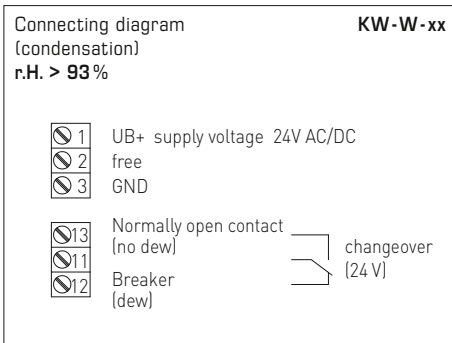
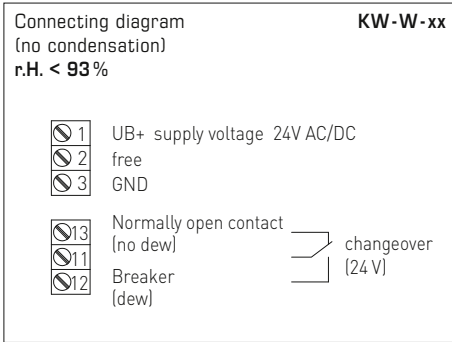
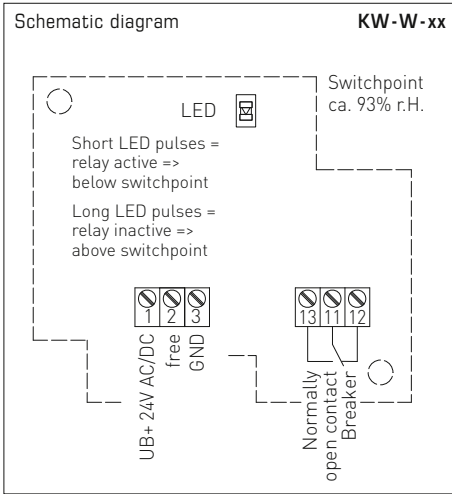

**HYGRASREG® KW-SD** Condensation control switches including strap, *Standard*  
**HYGRASREG® KW-SD-external** Condensation control switches with detached sensor head, *Standard*

Type / WG01B	Switchpoint Humidity	Output Humidity	Mounting	Item No.	Price
<b>KW-SD</b>			<b>Sensor internal</b>	<b>IP 54</b>	
KW-W-SD	ca. 93% r. H.	Changeover contact	for direct mounting on pipes, for direct mounting on flat surfaces	1202-1075-0001-020	<b>100,58 €</b>
<b>KW-SD-external</b>			<b>Sensor external</b>	<b>IP 54</b>	
KW-W-SD extern	ca. 93% r. H.	Changeover contact	for mounting on pipes	1202-1075-0001-040	<b>110,12 €</b>
Optional:	Cable connection with <b>M12 connector</b> according to DIN EN 61076-2-101			on request	



**KW**  
**KW-external**  
with quick-locking screws  
(IP 65)



**KW-SD**  
**KW-SD-external**  
with snap-on lid  
(IP54)

HYGRASREG® KW		Condensation control switches including strap, <i>Premium</i>			
HYGRASREG® KW-external		Condensation control switches with detached sensor head, <i>Premium</i>			
Type/WG01	Switchpoint Humidity	Output Humidity	Mounting	Item No.	Price
<b>KW</b>			<b>Sensor internal</b>	<b>IP 65</b>	
KW-W	ca. 93% r. H.	Changeover contact	for direct mounting on pipes, for direct mounting on flat surfaces	1202-1025-0001-020	<b>107,54 €</b>
<b>KW-external</b>			<b>Sensor external</b>	<b>IP 65</b>	
KW-W-extern	ca. 93% r. H.	Changeover contact	for mounting on pipes	1202-1025-0001-040	<b>130,62 €</b>
Optional:	Cable connection with <b>M12 connector</b> according to DIN EN 61076-2-101			on request	

**Dew point control switches including strap / with detached sensor head, with active / switching outputs**

**Patented quality product (pro-dynamic cross convection patent no. DE 10 2012 015 726.6)**

The dew point control switch **HYGRASREG® TW** is installed on cooling / cold-water piping or on cooled surfaces. It reliably detects formation of dew by means of its humidity and temperature sensor (no conductivity measurement) and, thanks to its patented measuring method, **pro-dynamic cross convection**, yields an exact measurement result (with LED status display), **with / without display**.

Dew point temperature is that temperature at which air reaches the state of saturation and water vapour starts to condensate. Facilitated by the continuous measuring range from 0...100% r.H. of the **TW-U** and the adjustable switchpoint for the **TW-W** of 75...100% r.H., it is possible to operate cooling ceilings, for example, so that the switching output of the dew point control switch, the DDC, is activated and then triggers a heater or other control elements, thereby preventing the formation of dew on pipes or cooling ceilings or on the property to be monitored.

**TW**  
with quick-locking screws



**TW-extern**  
with quick-locking screws



**TECHNICAL DATA**

Power supply:	24 V AC (± 20%) and 15...36 V DC
Power consumption:	< 1.1 VA / 24 V DC; < 2.2 VA / 24 V AC
Measuring Range:	formation of dew is detected at 0...100% r.H. on the <b>TW-U</b> , continuous 75...100% r.H. on the <b>TW-W</b> , switching (switchpoint adjustable by potentiometer, factory setting 75% r.H.)
Output:	0-10 V or potential-free changeover contact (24 V), 1 A ohmic load
Sensors:	<b>digital humidity sensor with integrated temperature sensor</b> , small hysteresis, high long-term stability
Sensor protection:	membrane filter
Medium:	clean air and non-aggressive, non-combustible gases
Housing:	plastic, UV-resistant, material polyamide, 30% glass-globe reinforced, with quick-locking screws (slotted / Phillips head combination), colour traffic white (similar to RAL 9016), housing cover is transparent!
Housing dimensions:	72 x 64 x 43.3 mm (Tyr 1)
Cable connection:	<b>cable gland</b> , plastic (M 16 x 1.5; with strain relief, exchangeable, inner diameter 10.4 mm) <b>or</b> <b>M12 connector</b> according to DIN EN 61076-2-101 (optional on request)
Electrical connection:	0.14 - 1.5 mm <sup>2</sup> , via terminal screws
Process connection:	endless strap with metal tightener, 300 mm, for pipes up to 3" diameter (included in the scope of delivery)
Mounting:	<b>TW</b> with strap for direct mounting on pipes or for direct mounting on flat surfaces (e.g. walls, ceilings)  <b>TW-external</b> with detached sensor head (cable length KL = 1.5 m) for mounting on pipes
Protection class:	III (according to EN 60 730)
Protection type:	<b>IP65</b> (according to EN 60529) Housing tested, TÜV SÜD, Report No. 713139052 (Tyr 1)
Standards:	CE conformity, electromagnetic compatibility according to EN 61 326, EMC directive 2014 / 30 / EU
Optional:	two-line <b>display with illumination</b> , cutout approx. 36x15 mm (W x H), for displaying actual humidity and the switching status of the relay

**FUNCTION** The relay output is triggered (contact 13-11 closed) if the **pre-set switchpoint** (factory setting 75% r.H.) is not reached and opens (contact 12-11 closed) in the event of an error (power failure, condensation).



**LED short pulses =**  
relay active → switchpoint not reached  
ACTUAL humidity < **pre-set switchpoint** (no condensation)



**LED long pulses =**  
relay inactive → switchpoint exceeded  
ACTUAL humidity > **pre-set switchpoint** (condensation)





Dew point control switches including strap/with detached sensor head, with active/switching outputs



Dimensional drawing TW

**M12 connector**  
(optional on request)

TW with display and quick-locking screws



Dimensional drawing TW-external

**M12 connector**  
(optional on request)

TW-extern with display and quick-locking screws



Dew point control switches including strap / with detached sensor head, with active / switching outputs

TW pro-dynamic cross convection

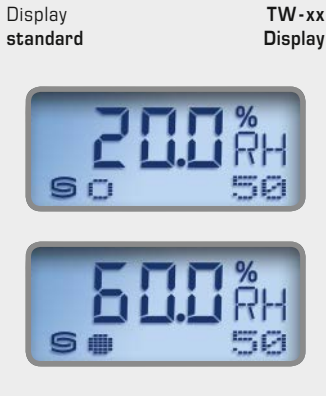

By default, the first line of the display shows the **relative humidity**.

The second line shows the information about the **switching status of the relay** (as a circuit) on the left, and the respective **switching value** in % r.H. on the right (switchpoint adjustable by potentiometer, factory setting 75% r.H.).

- **Circuit, empty** = relay in idle state
- **Circuit, full** = relay energised

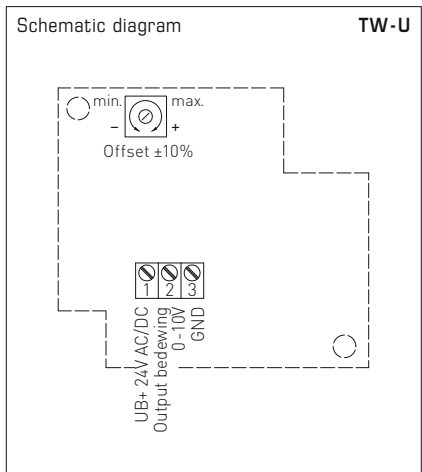
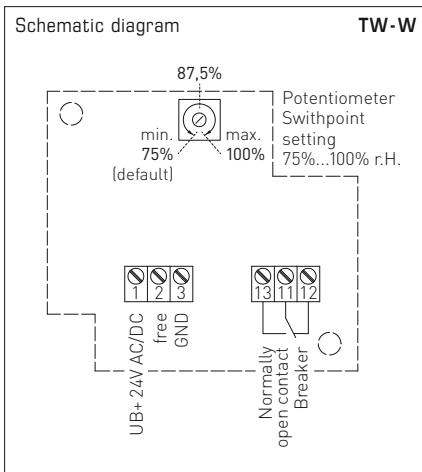
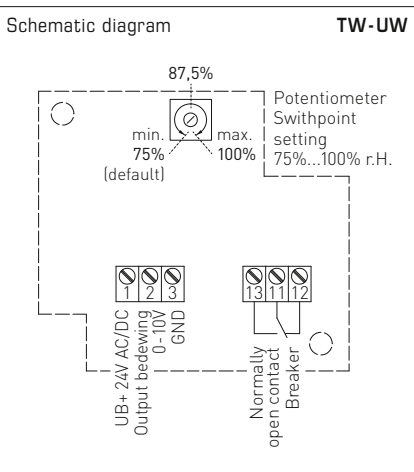
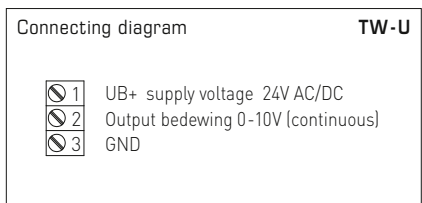
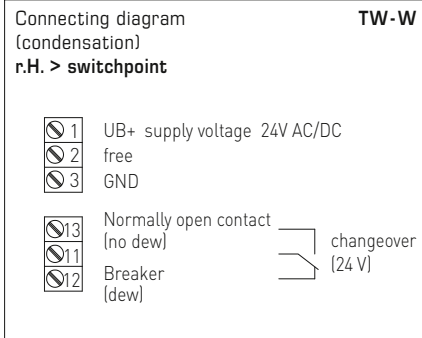
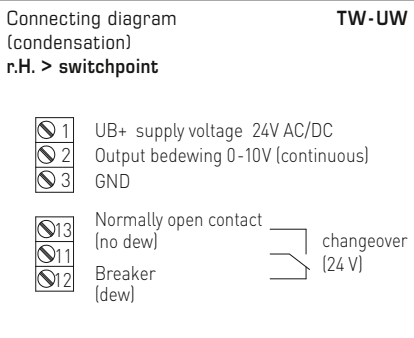
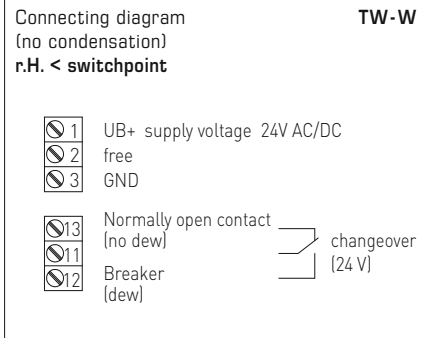
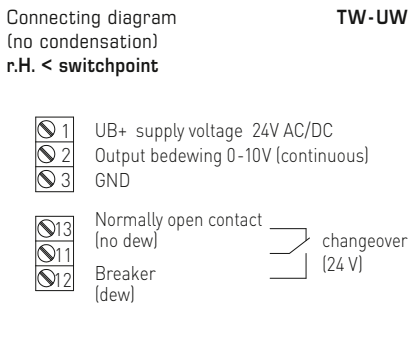



Dew point control switches including strap/with detached sensor head, with active/switching outputs

TW  
with display



TW-external  
with display



**HYGRASREG® TW**

Dew point control switches including strap (± 3%), *Deluxe*

**HYGRASREG® TW-external**

Dew point control switches with detached sensor head (± 3%), *Deluxe*

Type/ WG01	Measuring Range Humidity	Output Humidity	Mounting	Display	Item No.	Price
			<b>Sensor internal</b>		<b>IP 65</b>	
<b>TW</b>						
TW-W	75...100% r. H.	Changeover contact	for mounting directly on pipes		1202-1015-0001-000	<b>120,94 €</b>
TW-W LCD	75...100% r. H.	Changeover contact	for mounting directly on pipes	■	1202-1015-1201-020	<b>168,39 €</b>
TW-U	0...100% r. H.	0-10 V	for mounting directly on pipes		1201-1011-1001-020	<b>125,54 €</b>
TW-U/W	0...100% r. H.	0-10 V + Changeover contact	for mounting directly on pipes		1202-1012-1001-020	<b>143,96 €</b>
TW-U/W LCD	0...100% r. H.	0-10 V + Changeover contact	for mounting directly on pipes	■	1202-1012-1201-020	<b>191,43 €</b>
			<b>Sensor external</b>		<b>IP 65</b>	
<b>TW-external</b>						
TW-W-extern	75...100% r. H.	Changeover contact	for mounting on pipes		1202-1015-0021-030	<b>155,48 €</b>
TW-W-extern LCD	75...100% r. H.	Changeover contact	for mounting on pipes	■	1202-1015-0221-030	<b>202,92 €</b>
Optional:	Cable connection with <b>M12 connector</b> according to DIN EN 61076-2-101				on request	

**Leakage sensor / water ingress detector with switching output**

The leakage sensor / water ingress detector **HYGRASREG® LS** with leakage location is used to detect water ingresses and ingresses of conductive liquids. It is designed for the early detection of water leakages to protect sensitive electrical and electronic equipment in buildings against moisture. The water ingress detector consists of an electronic monitoring system with LED status indicator, and a matching electrode, which can be extended by the user.

LS-2



**TECHNICAL DATA**

Power supply:	24 V AC (±20%) and 15...36 V DC
Power consumption:	< 1.0 VA / 24 V DC; < 2.2 VA / 24 V AC
Operating range electronics module:	10...95% r. H.; 0...+50 °C
Monitoring range:	conductive liquids between the probes
Switching threshold:	conductance between electrodes > threshold
Output:	potential-free changeover contact (24 V), 1 A ohmic load
Housing:	plastic, UV-resistant, material polyamide, 30% glass-globe reinforced, with quick-locking screws (slotted / Phillips head combination), colour traffic white (similar to RAL 9016), housing cover is transparent!
Housing dimensions:	72 x 64 x 43.3 mm (Tyr 1)
Cable connection:	<b>cable gland</b> , plastic (M 16 x 1.5; with strain relief, exchangeable, inner diameter 10.4 mm) <b>or</b> <b>M12 connector</b> according to DIN EN 61076-2-101 (optional on request)
Electrical connection:	0.14 - 1.5 mm² via terminal screws
Process connection:	two external probes, laid according to measuring task (on the <b>LS-2</b> ) or upright on electrodes with insulating plastic caps, which are mounted on the housing underside (on the <b>LS-4</b> )
Mounting accessories:	for device type <b>LS-2</b> (2 electrodes 10 mm, already permanently mounted) <b>Electrode extension</b> 15 mm, 20 mm and 30 mm, 2 pieces each, stainless steel <b>V2A</b> (1.4301) (enclosed) <b>Cable sensor</b> , L = 1 m (optional)
Protection class:	III (according to EN 60 730)
Protection type:	<b>IP65</b> (according to EN 60 529) Housing tested, TÜV SÜD, Report No. 713139052 (Tyr 1)
Standards:	CE conformity, electromagnetic compatibility according to EN 61 326, EMC directive 2014 / 30 / EU
<b>FUNCTION</b>	The leak sensor can be set using DIP switches so that the relay is energised during normal operation. This means that relay opens in the event of a fault (water damage, cable breakage, power failure). This also enables a break in the cable to the sensor to be detected.

LS-4

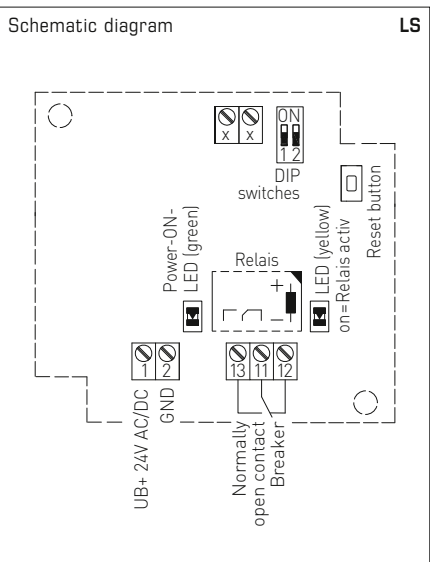

<b>Self-locking (selectable)</b>	<b>DIP 1</b>
Self-locking ON	ON
Self-locking OFF	OFF
<b>Relay status (selectable)</b>	<b>DIP 2</b>
Normally open contact OPEN	ON
Normally open contact CLOSED	OFF

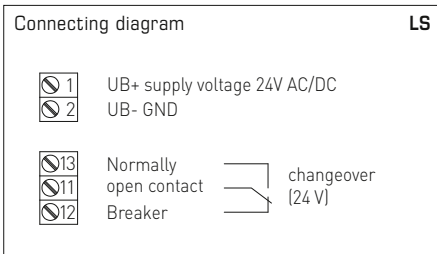

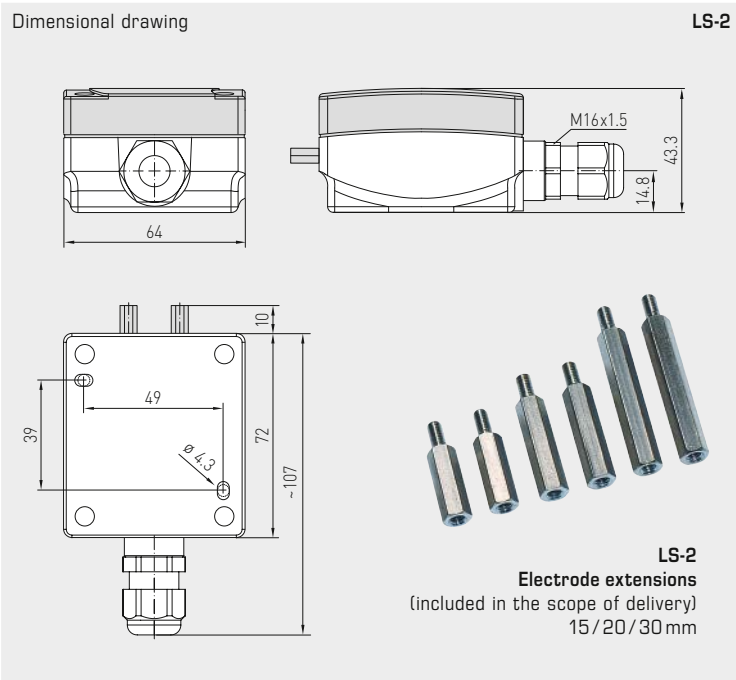

LS-2

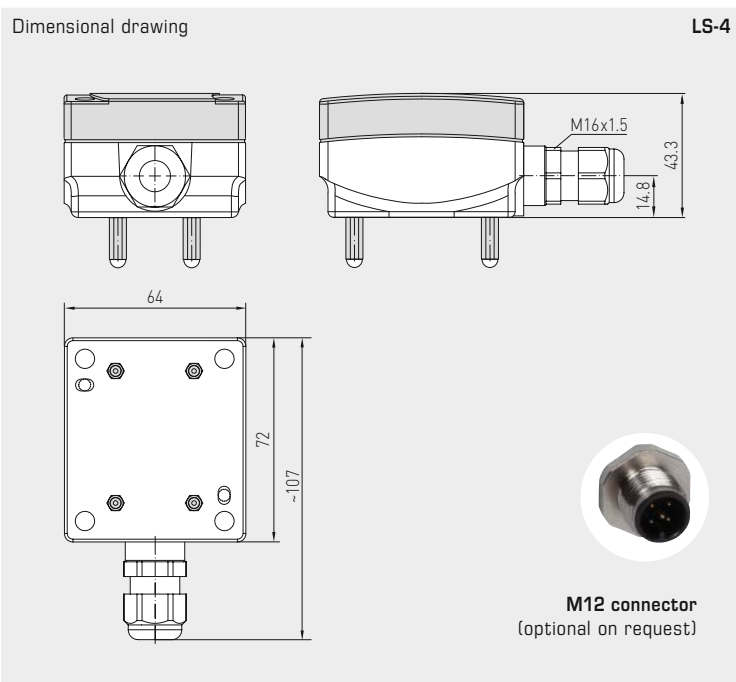

LS-4

HYGRASREG® LS Leakage sensor / water ingress detector				
Type / WG01	Detection of leakage of conductive liquids	Output Humidity (relative)	Item No.	Price
<b>LS</b>				
LS-2	Conductance > switching threshold	Changeover contact	1202-1042-0000-000	<b>99,25 €</b>
LS-4	Conductance > switching threshold	Changeover contact	1202-1042-0000-100	<b>112,35 €</b>
Optional:	Cable connection with <b>M12 connector</b> according to DIN EN 61076-2-101		on request	

ACCESSORIES				
LS-Kabelsonde	<b>Cable sensor</b> , L = 1 m, for device type <b>LS-2</b>		1202-1042-0000-001	<b>24,26 €</b>
For further information, see last chapter Accessories!				





## Pressure

Whether absolute or relative, atmospheric, differential or below-atmospheric – our **PREMASGARD®** and **PREMASREG®** devices can handle any kind of pressure and provide the right solution for any pressurized environment. High-precision piezo-resistive sensors ensure reliable performance from 25 Pa to 300 bar.

### APPLICATION RANGE

- > Process and mechanical engineering
- > Medical and cleanroom engineering
- > Large catering facilities
- > Heating, ventilation and air conditioning
- > Pump control and pressure lines
- > Filter monitoring and air pressure deficiency protection
- > Rotational speed and limit value control



## PREMASGARD® & PREMASREG®

458 – 527

for gaseous media  
[mbar / Pa]

PREMASGARD® 111x	Pressure measuring transducer	473
PREMASGARD® 112x	Pressure measuring transducer	473
PREMASGARD® 112x-SD	Pressure measuring transducer	472
PREMASGARD® 211x	Pressure measuring transducer	467
PREMASGARD® 212x	Pressure measuring transducer	467
PREMASGARD® 212x-SD	Pressure measuring transducer	466
PREMASGARD® 711x	Pressure measuring transducer	479
PREMASGARD® 711x-VA	Pressure measuring transducer (Stainless steel housing Tyr 2E)	485
PREMASGARD® 722x	Pressure measuring transducer, Dual pressure sensor (2 channels)	NEW 491
PREMASREG® 711x	Pressure measuring transducer, pressure controller/pressure switch	497
PREMASREG® 711x-VA	Pressure measuring transducer, pressure controller/pressure switch (Stainless steel housing Tyr 2E)	503
ALD	Measuring transducer [mbar] atmospheric pressure	517
DS 1 / DS 2	Differential pressure switch	521

for volume flow  
[mbar / Pa]

PREMASREG® 716x	Volume flow measuring transducer, pressure controller/pressure switch	509
PREMASREG® 716x-VA	Volume flow measuring transducer, pressure controller/pressure switch (Stainless steel housing Tyr 2E)	515

for liquid media  
[bar]

SHD	Pressure measuring transducer	523
SHD-SD	Pressure measuring transducer	523
SHD 400	Pressure measuring transducer	525
SHD 692	Pressure measuring transducer	527

Special accessories

see chapter Accessories 647



**NEW**





# Pressure



## PREMASGARD® & PREMASREG®

### Multifunctional sensor technology for the correct pressure

#### Broad Spectrum

Our pressure measuring transducers are designed to be multifunctional. This reduces the diversity of types while expanding their possible applications. Take advantage of our experience, our development, manufacturing and product know-how and order these products direct from the manufacturer S+S Regeltechnik. Thanks to microprocessor technology, almost any measuring range can be represented, including custom specifications. Multi-range switching, reaction times, units, automatic mode, and manual calibration are selectable via DIP switches.

#### Optimum Precision

The pressure sensors are developed and manufactured according to the latest criteria. They are fitted with the newest generation sensors that are linearised, temperature-compensated, and offer long-term and zero-point stability. The devices are produced at our factory and are calibrated and 100% tested at our test benches and pressure chambers. Each sensor is precisely re-adjustable using offset potentiometers. Take advantage of our experience, our development, manufacturing, and product know-how, and order these products directly from the manufacturer.

#### Approved Safety



RoHS conforming materials



ESD compliant manufacturing



CE compliance tested by external laboratories

#### Certified Quality



Our development and production in Nuremberg/Germany is certified by TÜV Thüringen according to DIN EN ISO 9001:2015.



GOST certificates



EAC certified



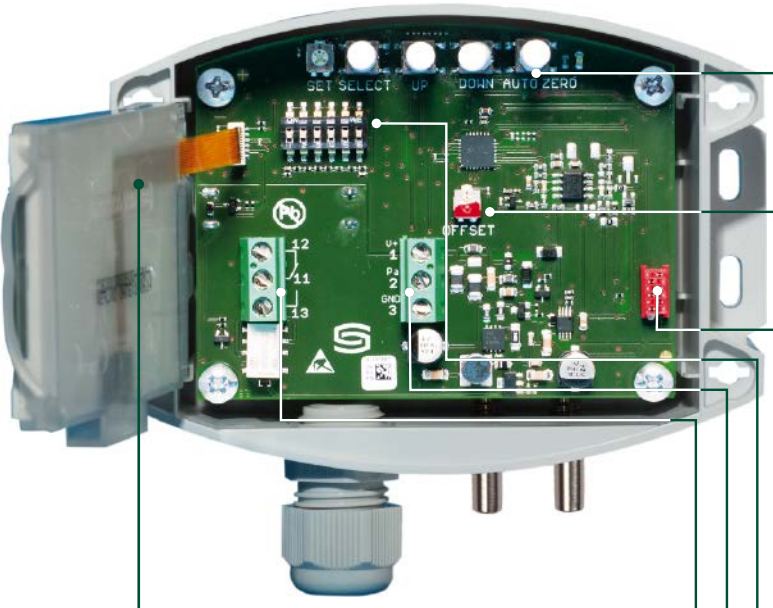

**Extra-Large Display (70 x 40 mm)**

With backlighting as well as display of range violation, sensor breakage, sensor short circuit and physical units



**Auto-Zero**

For zero point correction



**Offset Potentiometer**

For fine adjustment (zero point offset) and readjustment upon recalibration

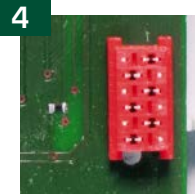

**Quality Assurance**

Calibration and balancing are done by means of the bus system at their pressure test bench

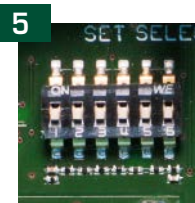

**DIP Switches**

For multi-range toggling as well as setting of 4 or 8 different measuring ranges, response times, damping times, units and configuration levels

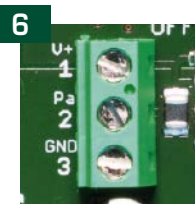

**Screw Terminals**

Active output signals 0-10V, 4...20 mA or switched output

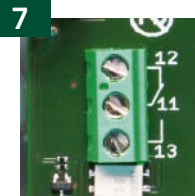

**Relais**

With optional automatic zero point calibration and valve for zero point correction



Pressure, differential pressure and volume flow measuring transducers, including connection set, compact form, adjustable, calibratable, with multi-range switching and active output

The calibrateable compact pressure sensors of the **PREMASGARD® 211x/212x/212x-SD** series are equipped with 8 switchable measuring ranges, 2 switchable output signals (16 devices in one) and with or without optional display and are used for measuring above-atmospheric, below-atmospheric, or differential pressures and Volume flow in air. The piezo-resistive measuring element is temperature-compensated and guarantees a high degree of reliability and accuracy. These pressure transmitters have a pushbutton for manual zero point calibration and an adjustable offset. Applications of these pressure sensors are in clean room, medical and filter technology, in ventilation and air conditioning ducts, in spray booths, in large-scale catering facilities, for monitoring filters, for level measurement or for triggering frequency converters. Media measured with these pressure transducers are air (non-precipitating), or other gaseous non-aggressive, non-combustible media. The differential pressure sensor is supplied including connection set **ASD-06** (2 m connection hose, two pressure connection nipples, screws). You can find further device types under **PREMASGARD® 111x/112x/112x-SD** (I variant with 2-wire connection).

**TECHNICAL DATA**

Power supply:	24 V AC/DC (± 10 %)
Working resistance:	R <sub>a</sub> (Ohm) = 25 ... 450 Ohm for I variant
Load resistance:	R <sub>L</sub> > 25 kOhm for U variant
Power consumption:	< 1 W at 24 V DC; < 2 VA at 24 V AC
Current consumption:	< 45 mA
Measuring function:	<b>Differential pressure, volume flow</b> (square root output signal)
Measuring ranges:	<b>multi-range switching with 8 switchable measuring ranges</b> (see table)
Output:	<b>switchable 0-10V / 4...20 mA</b> (via DIP switches)
Electrical connection:	3-wire connection
Media temperature:	-20...+50 °C (temperature-compensated 0...+50 °C)
Pressure connection:	with connection nozzles for pressure hose Ø 6 mm
Type of pressure:	differential pressure
Medium:	clean air and other non-aggressive, non-combustible gases
Accuracy:	<b>Type 2110/2120/2120-SD</b> (100 Pa): typically ± 3 Pa at +25 °C <b>Type 2111/2121/2121-SD</b> (1000 Pa): typically ± 10 Pa at +25 °C <b>Type 2115/2125/2125-SD</b> (5000 Pa): typically ± 35 Pa at +25 °C compared to the calibrated reference device
Zero point offset:	± 10 % of final value
Above- / below-atmospheric pressure:	± 50 kPa
Long-term stability:	± 1 % per year
Signal filtering:	<b>switchable 1 s / 10 s</b> (via DIP switches)
Hysteresis:	0.3 % of final value
Media contacting parts:	Brass, Ni, Duroplast, Si, epoxy, RTV, BSG, UV silicone gel
Temperature drift values:	± 0.1 % of final value / °C
Linearity:	< ± 1 % of final value
Housing:	plastic, UV-resistant, material polyamide, 30 % glass-globe reinforced, colour traffic white (similar to RAL 9016), housing cover for display is transparent! <b>Type 211x/212x:</b> with quick-locking screws (slotted/Phillips head combination) <b>Type 212x-SD:</b> with snap-on lid
Housing dimensions:	72 x 64 x 37.8 mm (Tyr 1 / Tyr 01 without display) 72 x 64 x 43.3 mm (Tyr 1 / Tyr 01 with display)
Cable connection:	<b>cable gland</b> , plastic (M 16 x 1.5; with strain relief, exchangeable, max. inner diameter 10.4 mm) or <b>M12 connector</b> according to DIN EN 61076-2-101 (optional on request)
Electrical connection:	0.14 - 1.5 mm <sup>2</sup> , via terminal screws
Humidity:	< 95 % r. H., non-precipitating air
Protection class:	III (according to EN 60 730)
Protection type:	<b>Type 211x/212x:</b> <b>IP 67</b> (according to EN 60 529)* Housing tested, TÜV SÜD, Report No. 713139052 (Tyr 1) <b>Type 212x-SD:</b> <b>IP 54</b> (according to EN 60 529)* Housing tested, TÜV SÜD, Report No. 713160960A (Tyr 01) * Housing in the built-in state
Standards:	CE conformity, electromagnetic compatibility according to EN 61 326, EMC directive 2014 / 30 / EU
Features:	two-line <b>display with illumination</b> , cutout approx. 36 x 15 mm (W x H), to display ACTUAL pressure
<b>ACCESSORIES</b>	see table

**PREMASGARD® 211x**  
Pressure connectors **on the top side**, with quick-locking screws (IP 67)



**PREMASGARD® 212x**  
Pressure connectors **on the bottom side**, with quick-locking screws (IP 67)



**PREMASGARD® 212x-SD**  
Pressure connectors **on the bottom side**, with snap-on lid (IP 54)







S+S REGELTECHNIK

Pressure, differential pressure and volume flow measuring transducers, including connection set, compact form, adjustable, calibratable, with multi-range switching and active output



Dimensional drawing

PREMASGARD® 211x

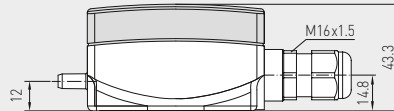
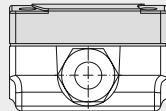
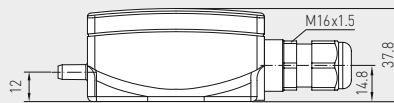
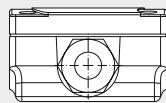
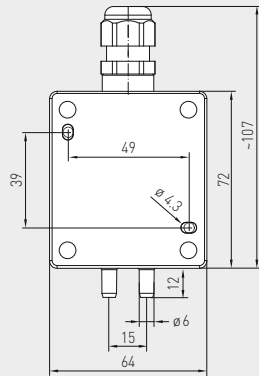

with display

without display

PREMASGARD® 211x

Pressure connectors on the top side, with display, with quick-locking screws (IP67)



Dimensional drawing

PREMASGARD® 212x  
PREMASGARD® 212x-SD

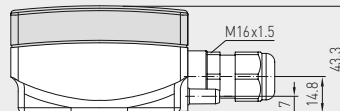
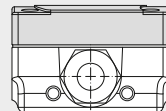
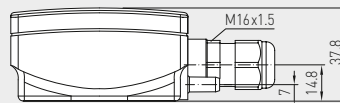
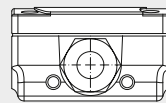
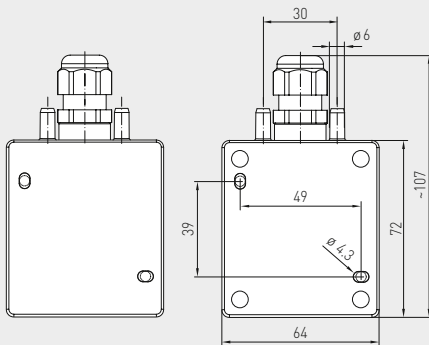

with display

without display

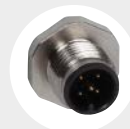
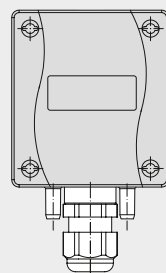
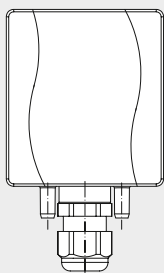

with snap-on lid

with quick-locking screws

M12 connector (optional on request)

PREMASGARD® 212x

Pressure connectors on the bottom side, with display, with quick-locking screws (IP67)



PREMASGARD® 212x-SD

Pressure connectors on the bottom side, with display, with snap-on lid (IP54)



Pressure, differential pressure and volume flow measuring transducers, including connection set, compact form, adjustable, calibratable, with multi-range switching and active output

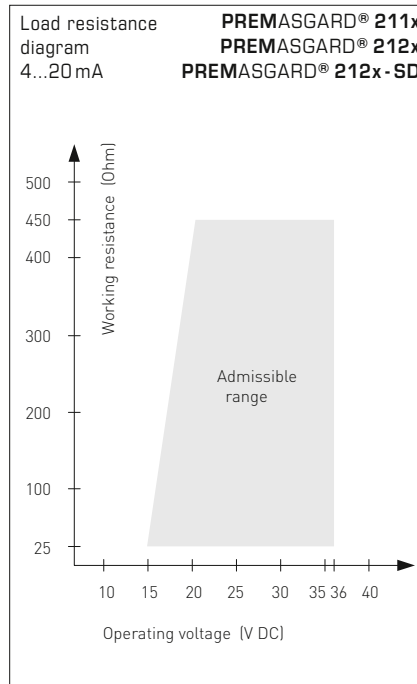
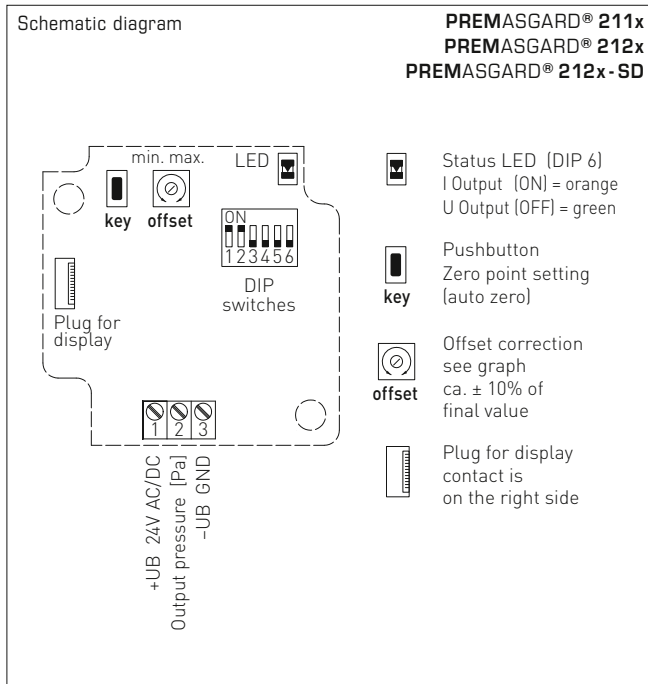

Pressure range (selectable) – max. measuring range (default) is depending on the type of device						DIP 1	DIP 2
0...50 Pa	0...100 Pa	0...1000 Pa	-50...+50 Pa	-100...+100 Pa	-1000...+1000 Pa	OFF	OFF
-	0...300 Pa	0...2000 Pa	-	-300...+300 Pa	-2000...+2000 Pa	ON	OFF
-	0...500 Pa	0...3000 Pa	-	-500...+500 Pa	-3000...+3000 Pa	OFF	ON
0...100 Pa	0...1000 Pa	0...5000 Pa	-100...+100 Pa	-1000...+1000 Pa	-5000...+5000 Pa	ON	ON

Output characteristic line (Mode selectable)	DIP 4
Linear (default) (for pressure detection)	OFF
Square root extracting (to determine the volume flow)	ON

Measuring range mode (Mode selectable)	DIP 3
Unidirectional (0...+MR) (default)	OFF
Bidirectional (-MR...+MR)	ON

Measurement signal filtering (Time interval selectable)	DIP 5
10 s (default)	OFF
1 s	ON

Output (selectable)	DIP 6
Voltage 0-10 V (default)	OFF
Current 4...20 mA	ON

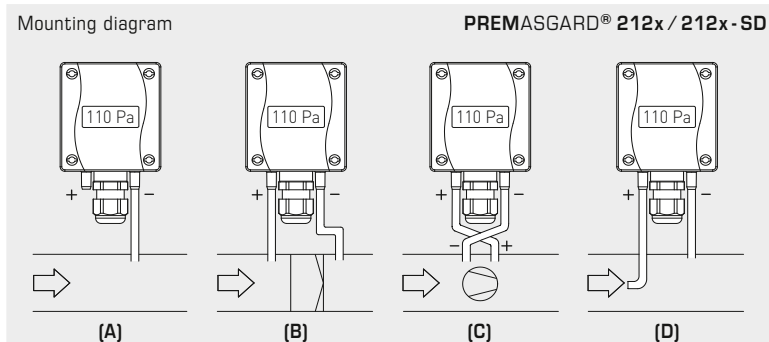
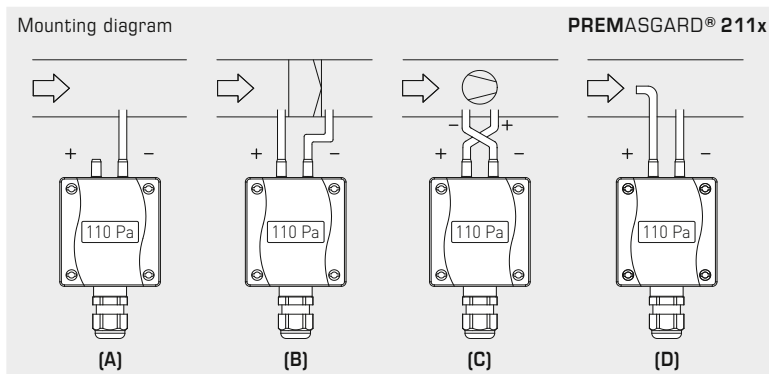

**TYPES OF MONITORING:**

Pressure connections at the pressure switch are marked with P1 (+) for higher pressure and P2 (-) for lower pressure.

**(A) Below-atmospheric pressure**

P1 (+) is not connected, but open to the atmosphere  
P2 (-) connected to inside of duct

**(B) Filter**

P1 (+) connected upstream of filter  
P2 (-) connected downstream of filter

**(C) Ventilator**

P1 (+) connected downstream of ventilator  
P2 (-) connected upstream of ventilator

**(D) Volume flow**

P1 (+) dynamic pressure, connected in flow direction  
P2 (-) static pressure, connected free of dynamic pressure components

$$V = k \cdot \sqrt{\Delta p}$$

V = Volume flow

k = K factor

Δp = Differential pressure [Pa]



S+S REGELTECHNIK

Pressure, differential pressure and volume flow measuring transducers, including connection set, compact form, adjustable, calibratable, with multi-range switching and active output

**PREMASGARD® 211x**  
Pressure connectors  
on the top side,  
with display



**PREMASGARD® 212x**  
Pressure connectors  
on the bottom side,  
with display



**WS-04**

Weather and sun protection hood  
(optional)



**Conversion table for pressure values:**

Unit =	bar	mbar	Pa	kPa	mWS
1 Pa	0.00001 bar	0.01 mbar	1 Pa	0.001 kPa	0.000101971 mWS
1 kPa	0.01 bar	10 mbar	1000 Pa	1 kPa	0.101971 mWS
1 bar	1 bar	1000 mbar	100000 Pa	100 kPa	10.1971 mWS
1 mbar	0.001 bar	1 mbar	100 Pa	0.1 kPa	0.0101971 mWS
1 mWS	0.0980665 bar	98.0665 mbar	9806.65 Pa	9.80665 kPa	1 mWS



Pressure, differential pressure and volume flow measuring transducers, including connection set, compact form, adjustable, calibratable, with multi-range switching and active output

Dimensional drawing **ASD-06**  
Connection set

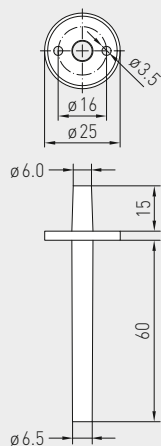

**ASD-06**  
Connection set



Dimensional drawing **ASD-07**  
Connection nipple

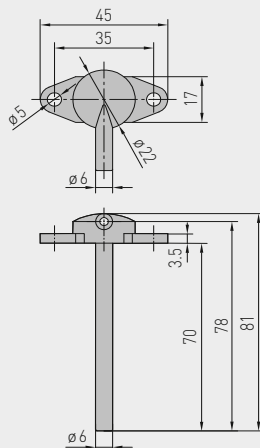

**ASD-07**  
Connection nipple



Dimensional drawing **DAL-01**  
Pressure outlet

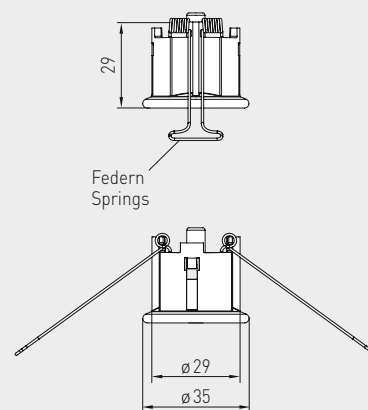

**DAL-01**  
Pressure outlet



ACCESSORIES		Item No.	Price
<b>ASD-06</b>	<b>Connection set (included in the scope of delivery)</b> , consisting of 2 connection nipples (straight) made of ABS, 2 m PVC hose (soft, UV-resistant) and 4 screws	7100-0060-3000-000	<b>7,28 €</b>
<b>ASD-07</b>	<b>2 connection nipples</b> (at 90 degree angle) made of plastic, ABS	7100-0060-7000-000	<b>7,28 €</b>
<b>DAL-01</b>	<b>Pressure outlet</b> for ceiling or in-wall installation (e.g. in clean rooms)	7300-0060-3000-001	<b>34,07 €</b>
<b>WS-04</b>	<b>Weather and sun protection hood</b> , 130 x 180 x 135 mm, stainless steel <b>V2A</b> (1.4301)	7100-0040-7000-000	<b>35,70 €</b>

For further information, see last chapter Accessories!

**PREMASGARD® 212x-SD** Pressure, differential pressure and volume flow measuring transducers, *Standard* (Pressure connectors on the bottom side)

Pressure range (Ranges adjustable)	Type / WGD1B (3-wire connection)	Output (switchable)	Display	Item No. (with snap-on lid)	Price
<b>max. - 1000...+ 1000 Pa</b>	<b>PREMASGARD® 2121-SD</b>			<b>IP 54</b>	
0... 100 Pa / - 100...+ 100 Pa	PREMASGARD 2121-SD	0-10V / 4...20mA		1301-11B7-0010-000	<b>129,99 €</b>
0... 300 Pa / - 300...+ 300 Pa	PREMASGARD 2121-SD <b>LCD</b>	0-10V / 4...20mA	■	1301-11B7-2010-000	<b>176,26 €</b>
0... 500 Pa / - 500...+ 500 Pa					
0... 1000 Pa / -1000...+ 1000 Pa					
<b>max. - 5000...+ 5000 Pa</b>	<b>PREMASGARD® 2125-SD</b>			<b>IP 54</b>	
0...1000 Pa / -1000...+1000 Pa	PREMASGARD 2125-SD	0-10V / 4...20mA		1301-11B7-0050-000	<b>129,99 €</b>
0...2000 Pa / -2000...+2000 Pa	PREMASGARD 2125-SD <b>LCD</b>	0-10V / 4...20mA	■	1301-11B7-2050-000	<b>176,26 €</b>
0...3000 Pa / -3000...+3000 Pa					
0...5000 Pa / -5000...+5000 Pa					
<b>max. - 100...+ 100 Pa</b>	<b>PREMASGARD® 2120-SD</b>			<b>IP 54</b>	
0... 50 Pa / - 50...+ 50 Pa	PREMASGARD 2120-SD	0-10V / 4...20mA		1301-11B7-0110-000	<b>129,99 €</b>
0... 100 Pa / -100...+ 100 Pa	PREMASGARD 2120-SD <b>LCD</b>	0-10V / 4...20mA	■	1301-11B7-2110-000	<b>176,26 €</b>
Multi-range switching:	The <b>pressure ranges</b> depend on the device type and can be set via DIP switches.				
Output:	<b>0-10V or 4...20mA</b> (selectable via DIP switches)				
Optional:	Cable connection with <b>M12 connector</b> according to DIN EN 61076-2-101 (on request)				



S+S REGELTECHNIK

Pressure, differential pressure and volume flow measuring transducers, including connection set, compact form, adjustable, calibratable, with multi-range switching and active output

**PREMASGARD® 211x**

Pressure connectors **on the top side**, with/without display, with quick-locking screws (IP 67)

**PREMASGARD® 212x**

Pressure connectors **on the bottom side**, with/without display, with quick-locking screws (IP 67)

**PREMASGARD® 212x-SD**

Pressure connectors **on the bottom side**, with/without display, with snap-on lid (IP 54)



PREMASGARD® 211x		Pressure, differential pressure and volume flow measuring transducers, <i>Premium</i> (Pressure connectors on the top side)			
Pressure range (Ranges adjustable)	Type /WG01 (3-wire connection)	Output (switchable)	Display	Item No. (with quick-locking screws)	Price
<b>max. - 1000...+ 1000 Pa</b>	<b>PREMASGARD® 2111</b>			<b>IP 67</b>	
0... 100 Pa / - 100...+ 100 Pa	PREMASGARD 2111	0-10V / 4...20mA		1301-1197-0010-000	<b>144,87 €</b>
0... 300 Pa / - 300...+ 300 Pa	PREMASGARD 2111 LCD	0-10V / 4...20mA	■	1301-1197-2010-000	<b>193,09 €</b>
0... 500 Pa / - 500...+ 500 Pa					
0... 1000 Pa / - 1000...+ 1000 Pa					
<b>max. - 5000...+ 5000 Pa</b>	<b>PREMASGARD® 2115</b>			<b>IP 67</b>	
0...1000 Pa / - 1000...+ 1000 Pa	PREMASGARD 2115	0-10V / 4...20mA		1301-1197-0050-000	<b>144,87 €</b>
0...2000 Pa / - 2000...+ 2000 Pa	PREMASGARD 2115 LCD	0-10V / 4...20mA	■	1301-1197-2050-000	<b>193,09 €</b>
0...3000 Pa / - 3000...+ 3000 Pa					
0...5000 Pa / - 5000...+ 5000 Pa					
<b>max. - 100...+ 100 Pa</b>	<b>PREMASGARD® 2110</b>			<b>IP 67</b>	
0... 50 Pa / - 50...+ 50 Pa	PREMASGARD 2110	0-10V / 4...20mA		1301-1197-0110-000	<b>144,87 €</b>
0... 100 Pa / - 100...+ 100 Pa	PREMASGARD 2110 LCD	0-10V / 4...20mA	■	1301-1197-2110-000	<b>193,09 €</b>
Multi-range switching:	The <b>pressure ranges</b> depend on the device type and can be set via DIP switches.				
Output:	<b>0-10V or 4...20mA</b> (selectable via DIP switches)				
Optional:	Cable connection with <b>M12 connector</b> according to DIN EN 61076-2-101 (on request)				

PREMASGARD® 212x		Pressure, differential pressure and volume flow measuring transducers, <i>Premium</i> (Pressure connectors on the bottom side)			
Pressure range (Ranges adjustable)	Type /WG01 (3-wire connection)	Output (switchable)	Display	Item No. (with quick-locking screws)	Price
<b>max. - 1000...+ 1000 Pa</b>	<b>PREMASGARD® 2121</b>			<b>IP 67</b>	
0... 100 Pa / - 100...+ 100 Pa	PREMASGARD 2121	0-10V / 4...20mA		1301-11A7-0010-000	<b>144,87 €</b>
0... 300 Pa / - 300...+ 300 Pa	PREMASGARD 2121 LCD	0-10V / 4...20mA	■	1301-11A7-2010-000	<b>193,09 €</b>
0... 500 Pa / - 500...+ 500 Pa					
0... 1000 Pa / - 1000...+ 1000 Pa					
<b>max. - 5000...+ 5000 Pa</b>	<b>PREMASGARD® 2125</b>			<b>IP 67</b>	
0...1000 Pa / - 1000...+ 1000 Pa	PREMASGARD 2125	0-10V / 4...20mA		1301-11A7-0050-000	<b>144,87 €</b>
0...2000 Pa / - 2000...+ 2000 Pa	PREMASGARD 2125 LCD	0-10V / 4...20mA	■	1301-11A7-2050-000	<b>193,09 €</b>
0...3000 Pa / - 3000...+ 3000 Pa					
0...5000 Pa / - 5000...+ 5000 Pa					
<b>max. - 100...+ 100 Pa</b>	<b>PREMASGARD® 2120</b>			<b>IP 67</b>	
0... 50 Pa / - 50...+ 50 Pa	PREMASGARD 2120	0-10V / 4...20mA		1301-11A7-0110-000	<b>144,87 €</b>
0... 100 Pa / - 100...+ 100 Pa	PREMASGARD 2120 LCD	0-10V / 4...20mA	■	1301-11A7-2110-000	<b>193,09 €</b>
Multi-range switching:	The <b>pressure ranges</b> depend on the device type and can be set via DIP switches.				
Output:	<b>0-10V or 4...20mA</b> (selectable via DIP switches)				
Optional:	Cable connection with <b>M12 connector</b> according to DIN EN 61076-2-101 (on request)				



I variant  
with 2-wire  
connection



S+S REGELTECHNIK

Pressure, differential pressure and volume flow measuring transducers, including connection set, compact form, adjustable, calibratable, with multi-range switching and active output

The calibrateable compact pressure sensors of the **PREMASGARD® 111x / 112x / 112x-SD** series are equipped with eight switchable measuring ranges and with or without optional display (eight devices in one) and are used for measuring above-atmospheric, below-atmospheric, or differential pressures and Volume flow in air. The piezo-resistive measuring element is temperature-compensated and guarantees a high degree of reliability and accuracy. These pressure transmitters have a pushbutton for manual zero point calibration and an adjustable offset. Applications of these pressure sensors are in clean room, medical and filter technology, in ventilation and air conditioning ducts, in spray booths, in large-scale catering facilities, for monitoring filters, for level measurement or for triggering frequency converters. Media measured with these pressure transducers are air (non-precipitating), or other gaseous non-aggressive, non-combustible media. The differential pressure sensor is supplied including connection set **ASD-06** (2m connection hose, two pressure connection nipples, screws). You can find further device types under **PREMASGARD® 211x / 212x / 212x-SD** (3-conductor connection) with switchable output (0-10V / 4...20 mA).

**PREMASGARD® 111x**  
Pressure connectors  
**on the top side**  
with quick-locking screws  
(IP 67)



**PREMASGARD® 112x**  
Pressure connectors  
**on the bottom side**  
with quick-locking screws  
(IP 67)



**PREMASGARD® 112x-SD**  
Pressure connectors  
**on the bottom side**  
with snap-on lid  
(IP 54)



**TECHNICAL DATA**

Power supply:	24 V AC (±20 %); 15...36 V DC for U variant 15...36 V DC for I variant, depending on working resistance, residual ripple stabilised ± 0.3V
Working resistance:	$R_a \text{ (ohm)} = (U_b - 14 \text{ V}) / 0.02 \text{ A}$ for I variant
Load resistance:	$R_L > 5 \text{ kOhm}$ for U variant
Power consumption:	< 1 W at 24 V DC; < 2 VA at 24 V AC
Measuring function:	<b>Differential pressure, volume flow</b> (square root output signal)
Measuring ranges:	<b>multi-range switching with 8 switchable measuring ranges</b> (see table)
Output:	0 -10V or 4...20 mA
Electrical connection:	2- or 3-wire connection
Media temperature:	-20...+50 °C
Pressure connection:	with connection nozzles for pressure hose Ø 6 mm
Type of pressure:	differential pressure
Medium:	clean air and other non-aggressive, non-combustible gases
Accuracy:	<b>Type 1111 / 1121 / 1121-SD</b> (1000 Pa): typically ± 10 Pa <b>Type 1115 / 1125 / 1125-SD</b> (5000 Pa): typically ± 50 Pa <b>Type 1116 / 1126</b> (10000 Pa): typically ± 50 Pa compared to the calibrated reference device
Zero point offset:	± 10 % of final value
Above- / below-atmospheric pressure:	max. 5 x measuring range
Long-term stability:	± 1 % per year
Signal filtering:	<b>switchable 1 s / 10 s</b>
Hysteresis:	0.3 % of final value
Media contacting parts:	ms, Ni, Nylon, PU, Si, PVC with plasticisers
Temperature drift values:	± 0.1 % of final value / °C
Current consumption:	< 20 mA
Linearity:	< ± 1 % of final value
Housing:	plastic, UV-resistant, material polyamide, 30 % glass-globe reinforced, colour traffic white (similar to RAL 9016), housing cover for display is transparent! <b>Type 111x / 112x:</b> with quick-locking screws (slotted/Phillips head combination) <b>Type 112x-SD:</b> with snap-on lid
Housing dimensions:	72 x 64 x 37.8 mm (Tyr 1 / Tyr 01 without display) 72 x 64 x 43.3 mm (Tyr 1 / Tyr 01 with display)
Cable connection:	<b>cable gland</b> , plastic (M 16 x 1.5; with strain relief, exchangeable, inner diameter 10.4 mm) <b>or</b> <b>M12 connector</b> according to DIN EN 61076-2-101 (optional on request)
Electrical connection:	0.14 - 1.5 mm <sup>2</sup> , via terminal screws
Humidity:	< 95 % r. H., non-precipitating air
Protection class:	III (according to EN 60 730)
Protection type:	<b>Type 111x / 112x:</b> <b>IP 67</b> (according to EN 60 529)* Housing tested, TÜV SÜD, Report No. 713139052 (Tyr 1) <b>Type 112x-SD:</b> <b>IP 54</b> (according to EN 60 529)* Housing tested, TÜV SÜD, Report No. 713160960A (Tyr 01) * Housing in the built-in state
Standards:	CE conformity, electromagnetic compatibility according to EN 61 326, EMC directive 2014 / 30 / EU
Features:	two-line <b>display with illumination</b> , cutout approx. 36 x 15 mm (W x H), to display <b>ACTUAL</b> pressure
<b>ACCESSORIES</b>	see table



S+S REGELTECHNIK

1 variant with 2-wire connection

Pressure, differential pressure and volume flow measuring transducers, including connection set, compact form, adjustable, calibratable, with multi-range switching and active output

Dimensional drawing

PREMASGARD® 111x

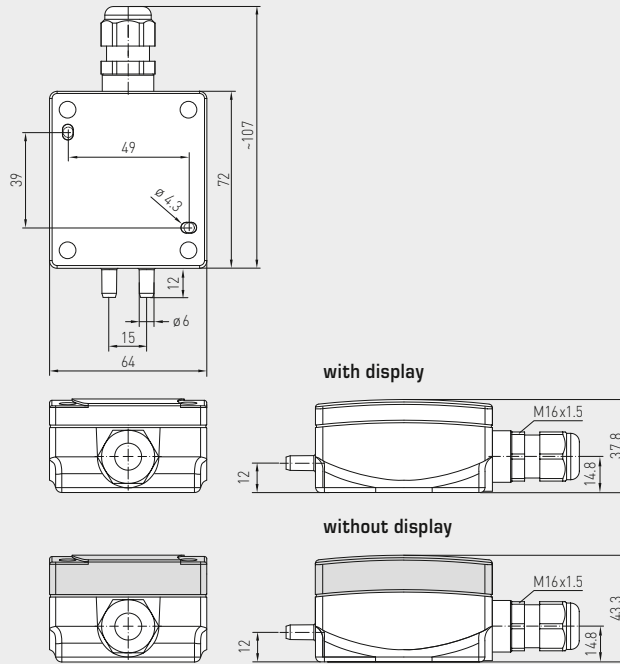

**PREMASGARD® 111x**  
Pressure connectors on the top side, with display, with quick-locking screws (IP67)



Dimensional drawing

PREMASGARD® 112x  
PREMASGARD® 112x-SD

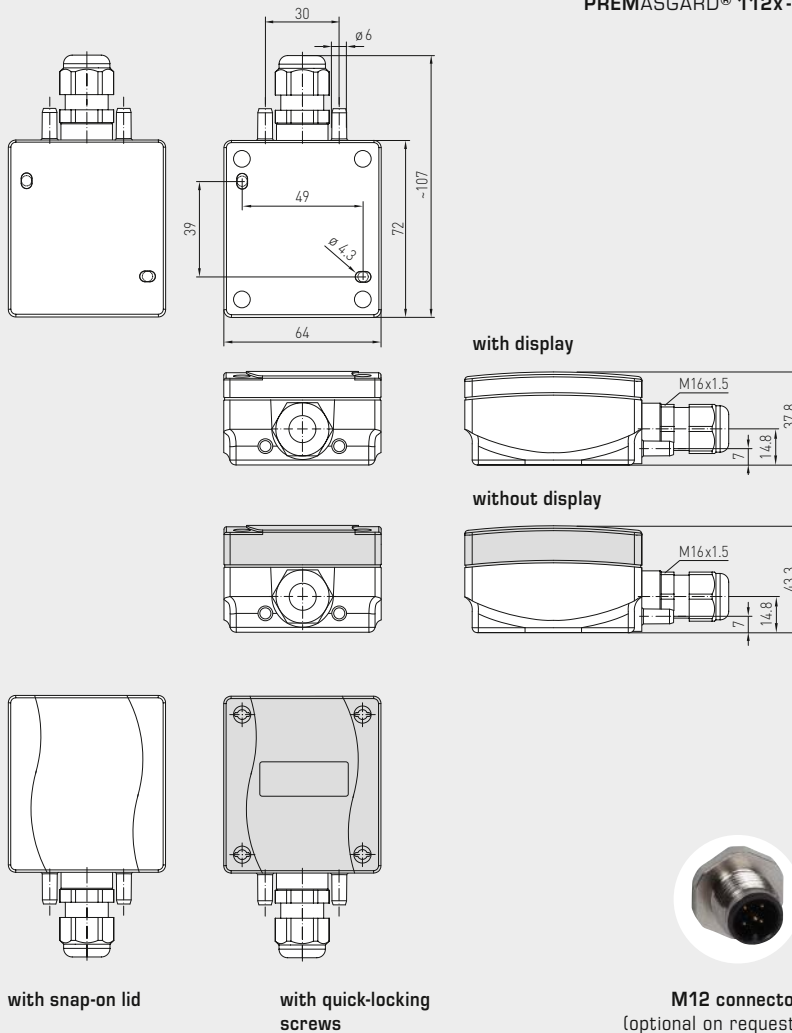

**PREMASGARD® 112x**  
Pressure connectors on the bottom side, with display, with quick-locking screws (IP67)



**PREMASGARD® 112x-SD**  
Pressure connectors on the bottom side, with display, with snap-on lid (IP54)



Pressure, differential pressure and volume flow measuring transducers, including connection set, compact form, adjustable, calibratable, with multi-range switching and active output

1 variant with 2-wire connection



S+S REGELTECHNIK

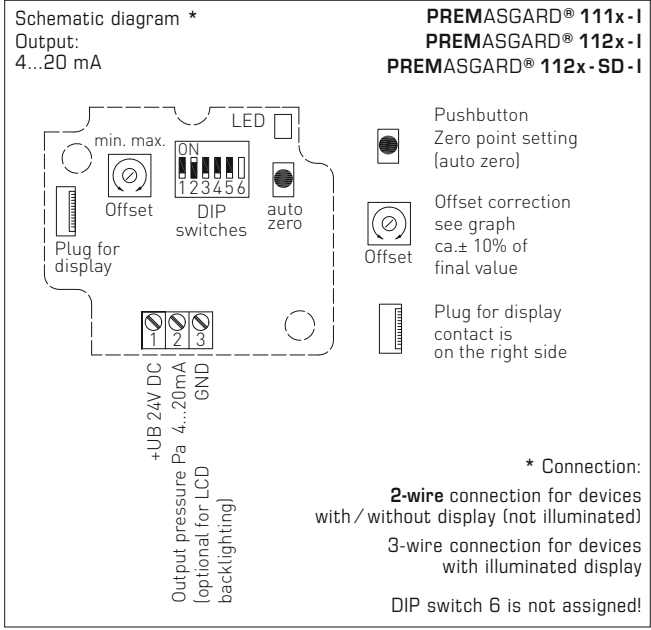
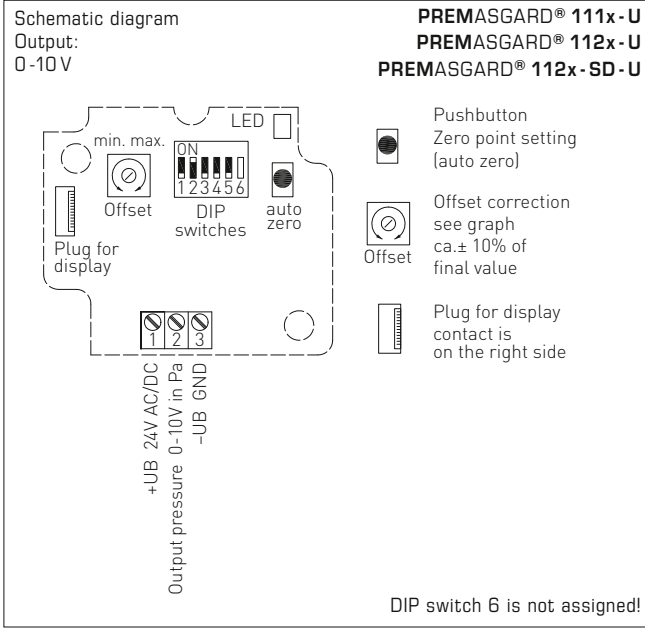

Pressure range (selectable) – max. measuring range (default) is depending to the type of device						DIP 1	DIP 2
0...100 Pa	0...1000 Pa	0...4000 Pa	-100...+100 Pa	-1000...+1000 Pa	-4000...+4000 Pa	OFF	OFF
0...300 Pa	0...2000 Pa	0...6000 Pa	-300...+300 Pa	-2000...+2000 Pa	-6000...+6000 Pa	ON	OFF
0...500 Pa	0...3000 Pa	0...8000 Pa	-500...+500 Pa	-3000...+3000 Pa	-8000...+8000 Pa	OFF	ON
0...1000 Pa	0...5000 Pa	0...10000 Pa	-1000...+1000 Pa	-5000...+5000 Pa	-10000...+10000 Pa	ON	ON

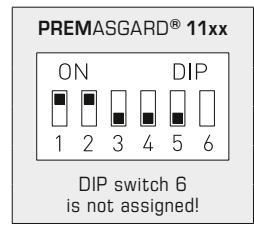

Measuring range mode (Mode selectable)	DIP 3
Unidirectional (0...+MR) (default)	OFF
Bidirectional (-MR...+MR)	ON

Output characteristic line (Mode selectable)	DIP 4
Linear (default) (for pressure detection)	OFF
Square root extracting (to determine the volume flow)	ON

Measurement signal filtering (Time interval selectable)	DIP 5
10 s (default)	OFF
1 s	ON

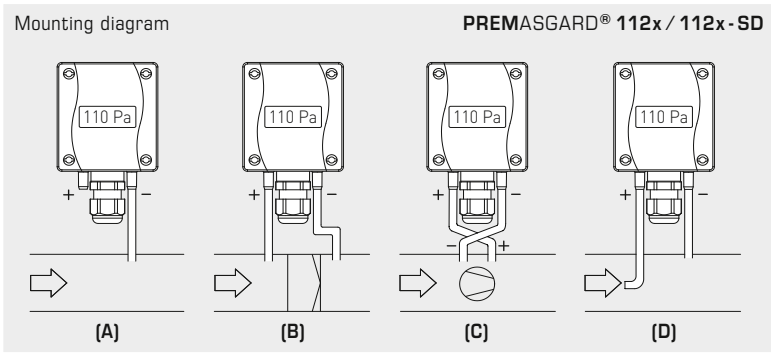
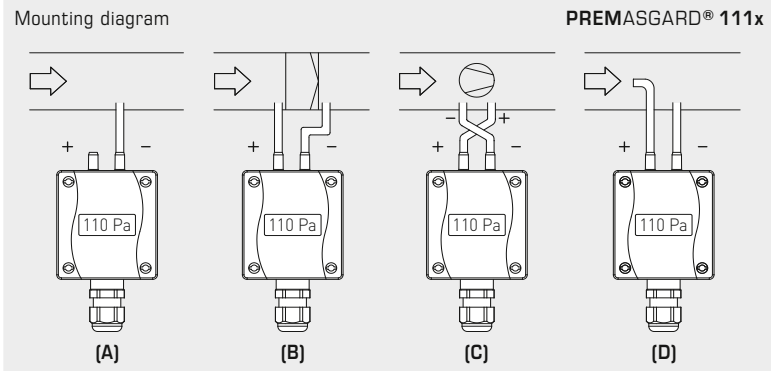

**TYPES OF MONITORING:**

- Pressure connections at the pressure switch are marked with P1 (+) for higher pressure and P2 (-) for lower pressure.
- (A) **Below-atmospheric pressure**  
P1 (+) is not connected, but open to the atmosphere  
P2 (-) connected to inside of duct
  - (B) **Filter**  
P1 (+) connected upstream of filter  
P2 (-) connected downstream of filter
  - (C) **Ventilator**  
P1 (+) connected downstream of ventilator  
P2 (-) connected upstream of ventilator
  - (D) **Volume flow**  
P1 (+) dynamic pressure, connected in flow direction  
P2 (-) static pressure, connected free of dynamic pressure components

$$V = k \cdot \sqrt{\Delta p}$$

V = Volume flow  
k = K factor  
 $\Delta p$  = Differential pressure [Pa]



S+S REGELTECHNIK

1 variant with 2-wire connection

PREMASGARD® 111x/112x/112x-SD

Pressure, differential pressure and volume flow measuring transducers, including connection set, compact form, adjustable, calibratable, with multi-range switching and active output

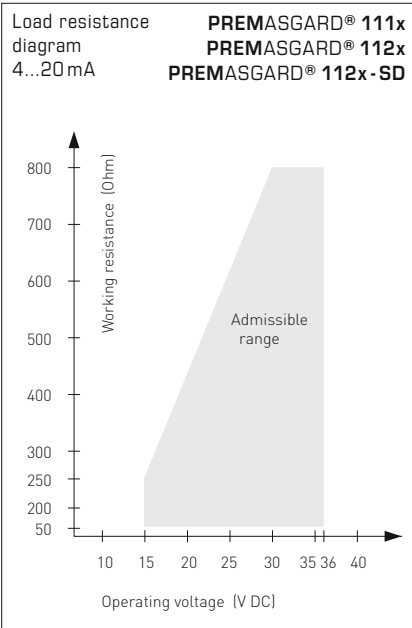

PREMASGARD® 111x  
Pressure connectors on the top side, with display



PREMASGARD® 112x  
Pressure connectors on the bottom side, with display



WS-04  
Weather and sun protection hood (optional)



Conversion table for pressure values:

Unit =	bar	mbar	Pa	kPa	mWS
1 Pa	0.00001 bar	0.01 mbar	1 Pa	0.001 kPa	0.000101971 mWS
1 kPa	0.01 bar	10 mbar	1000 Pa	1 kPa	0.101971 mWS
1 bar	1 bar	1000 mbar	100000 Pa	100 kPa	10.1971 mWS
1 mbar	0.001 bar	1 mbar	100 Pa	0.1 kPa	0.0101971 mWS
1 mWS	0.0980665 bar	98.0665 mbar	9806.65 Pa	9.80665 kPa	1 mWS

Pressure, differential pressure and volume flow measuring transducers, including connection set, compact form, adjustable, calibratable, with multi-range switching and active output

1 variant with 2-wire connection



S+S REGELTECHNIK

Dimensional drawing ASD-06 Connection set

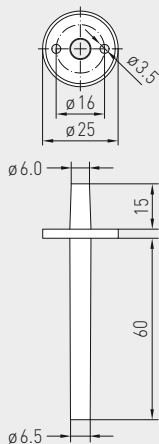

Dimensional drawing ASD-07 Connection nipple

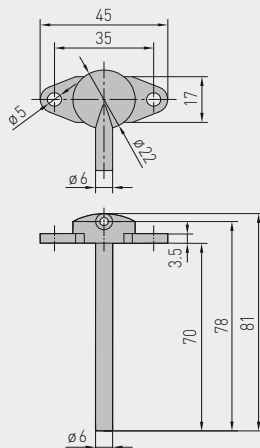

Dimensional drawing DAL-01 Pressure outlet

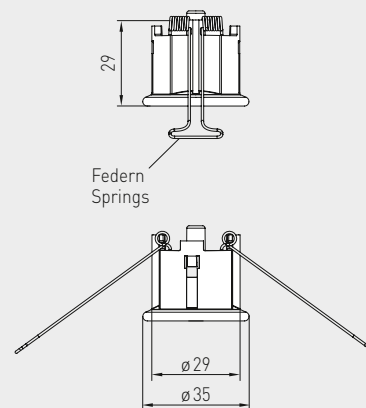

ASD-06 Connection set



ASD-07 Connection nipple



DAL-01 Pressure outlet

ACCESSORIES		Item No.	Price
<b>ASD-06</b>	<b>Connection set (included in the scope of delivery)</b> , consisting of 2 connection nipples (straight) made of ABS, 2 m PVC hose (soft, UV-resistant) and 4 screws	7100-0060-3000-000	<b>7,28 €</b>
<b>ASD-07</b>	<b>2 connection nipples</b> (at 90 degree angle) made of plastic, ABS	7100-0060-7000-000	<b>7,28 €</b>
<b>DAL-01</b>	<b>Pressure outlet</b> for ceiling or in-wall installation (e.g. in clean rooms)	7300-0060-3000-001	<b>34,07 €</b>
<b>WS-04</b>	<b>Weather and sun protection hood</b> , 130 x 180 x 135 mm, stainless steel <b>V2A</b> (1.4301)	7100-0040-7000-000	<b>35,70 €</b>

For further information, see last chapter Accessories!

**PREMASGARD® 112x-SD** Pressure, differential pressure and volume flow measuring transducers, *Standard* (Pressure connectors on the bottom side)

Pressure range (Ranges adjustable)	Type / WG01	Connection 2- or 3-wire	Output	Display	Item No (with snap-on lid)	Price
<b>max. - 1000...+ 1000 Pa</b>	<b>PREMASGARD® 1121-SD</b>				<b>IP 54</b>	
0... 100 Pa / - 100...+ 100 Pa	PREMASGARD 1121-SD-I	<b>2</b>	4...20 mA		1301-1182-0010-000	<b>142,83 €</b>
0... 300 Pa / - 300...+ 300 Pa	PREMASGARD 1121-SD-I LCD	<b>2/3</b>	4...20 mA	■	1301-1182-2010-000	<b>183,97 €</b>
0... 500 Pa / - 500...+ 500 Pa	-	<b>3</b>	0-10 V		see <b>PREMASGARD® 212x-SD</b>	
0... 1000 Pa / - 1000...+ 1000 Pa	-					
<b>max. - 5000...+ 5000 Pa</b>	<b>PREMASGARD® 1125-SD</b>				<b>IP 54</b>	
0... 1000 Pa / - 1000...+ 1000 Pa	PREMASGARD 1125-SD-I	<b>2</b>	4...20 mA		1301-1182-0050-000	<b>142,83 €</b>
0... 2000 Pa / - 2000...+ 2000 Pa	PREMASGARD 1125-SD-I LCD	<b>2/3</b>	4...20 mA	■	1301-1182-2050-000	<b>183,97 €</b>
0... 3000 Pa / - 3000...+ 3000 Pa	-	<b>3</b>	0-10 V		see <b>PREMASGARD® 212x-SD</b>	
0... 5000 Pa / - 5000...+ 5000 Pa	-					

Multi-range switching: The **pressure ranges** depend on the device type and can be set via DIP switches.  
 Optional: Cable connection with **M12 connector** according to DIN EN 61076-2-101 (on request)





S+S REGELTECHNIK

1 variant with 2-wire connection

PREMASGARD® 111x/112x/112x-SD

Pressure, differential pressure and volume flow measuring transducers, including connection set, compact form, adjustable, calibratable, with multi-range switching and active output

**PREMASGARD® 111x**

Pressure connectors on the top side, with/without display, with quick-locking screws (IP 67)

**PREMASGARD® 112x**

Pressure connectors on the bottom side, with/without display, with quick-locking screws (IP 67)

**PREMASGARD® 112x-SD**

Pressure connectors on the bottom side, with/without display, with snap-on lid (IP 54)



PREMASGARD® 111x		Pressure, differential pressure and volume flow measuring transducers, <i>Premium</i> (Pressure connectors on the top side)				
Pressure range (Ranges adjustable)	Type / WG01	Connection 2- or 3-wire	Output	Display	Item No (with quick-locking screws)	Price
<b>max. - 1000...+ 1000 Pa</b>	<b>PREMASGARD® 1111</b>				<b>IP 67</b>	
0... 100 Pa / - 100...+ 100 Pa	PREMASGARD 1111-I	2	4...20 mA		1301-1112-0010-000	144,87 €
0... 300 Pa / - 300...+ 300 Pa	PREMASGARD 1111-I LCD	2/3	4...20 mA	■	1301-1112-2010-000	193,09 €
0... 500 Pa / - 500...+ 500 Pa	-	3	0-10 V		see <b>PREMASGARD® 211x</b>	
0... 1000 Pa / - 1000...+ 1000 Pa	-	-	-		-	-
<b>max. - 5000...+ 5000 Pa</b>	<b>PREMASGARD® 1115</b>				<b>IP 67</b>	
0...1000 Pa / - 1000...+ 1000 Pa	PREMASGARD 1115-I	2	4...20 mA		1301-1112-0050-000	144,87 €
0...2000 Pa / - 2000...+ 2000 Pa	PREMASGARD 1115-I LCD	2/3	4...20 mA	■	1301-1112-2050-000	193,09 €
0...3000 Pa / - 3000...+ 3000 Pa	-	3	0-10 V		see <b>PREMASGARD® 211x</b>	
0...5000 Pa / - 5000...+ 5000 Pa	-	-	-		-	-
<b>max. - 10000...+ 10000 Pa</b>	<b>PREMASGARD® 1116</b>				<b>IP 67</b>	
0... 4000 Pa / - 4000...+ 4000 Pa	PREMASGARD 1116-I	2	4...20 mA		1301-1112-0060-000	168,15 €
0... 6000 Pa / - 6000...+ 6000 Pa	PREMASGARD 1116-I LCD	2/3	4...20 mA	■	1301-1112-2060-000	212,18 €
0... 8000 Pa / - 8000...+ 8000 Pa	PREMASGARD 1116-U	3	0-10 V		1301-1111-0060-000	168,15 €
0...10000 Pa / - 10000...+ 10000 Pa	PREMASGARD 1116-U LCD	3	0-10 V	■	1301-1111-2060-000	212,18 €
Multi-range switching:	The <b>pressure ranges</b> depend on the device type and can be set via DIP switches.					
Optional:	Cable connection with <b>M12 connector</b> according to DIN EN 61076-2-101 (on request)					

PREMASGARD® 112x		Pressure, differential pressure and volume flow measuring transducers, <i>Premium</i> (Pressure connectors on the bottom side)				
Pressure range (Ranges adjustable)	Type / WG01	Connection 2- or 3-wire	Output	Display	Item No (with quick-locking screws)	Price
<b>max. - 1000...+ 1000 Pa</b>	<b>PREMASGARD® 1121</b>				<b>IP 67</b>	
0... 100 Pa / - 100...+ 100 Pa	PREMASGARD 1121-I	2	4...20 mA		1301-1172-0010-000	144,87 €
0... 300 Pa / - 300...+ 300 Pa	PREMASGARD 1121-I LCD	2/3	4...20 mA	■	1301-1172-2010-000	193,09 €
0... 500 Pa / - 500...+ 500 Pa	-	3	0-10 V		see <b>PREMASGARD® 212x</b>	
0... 1000 Pa / - 1000...+ 1000 Pa	-	-	-		-	-
<b>max. - 5000...+ 5000 Pa</b>	<b>PREMASGARD® 1125</b>				<b>IP 67</b>	
0...1000 Pa / - 1000...+ 1000 Pa	PREMASGARD 1125-I	2	4...20 mA		1301-1172-0050-000	144,87 €
0...2000 Pa / - 2000...+ 2000 Pa	PREMASGARD 1125-I LCD	2/3	4...20 mA	■	1301-1172-2050-000	193,09 €
0...3000 Pa / - 3000...+ 3000 Pa	-	3	0-10 V		see <b>PREMASGARD® 212x</b>	
0...5000 Pa / - 5000...+ 5000 Pa	-	-	-		-	-
<b>max. - 10000...+ 10000 Pa</b>	<b>PREMASGARD® 1126</b>				<b>IP 67</b>	
0... 4000 Pa / - 4000...+ 4000 Pa	PREMASGARD 1126-I	2	4...20 mA		1301-1172-0060-000	168,15 €
0... 6000 Pa / - 6000...+ 6000 Pa	PREMASGARD 1126-I LCD	2/3	4...20 mA	■	1301-1172-2060-000	212,18 €
0... 8000 Pa / - 8000...+ 8000 Pa	PREMASGARD 1126-U	3	0-10 V		1301-1171-0060-000	168,15 €
0...10000 Pa / - 10000...+ 10000 Pa	PREMASGARD 1126-U LCD	3	0-10 V	■	1301-1171-2060-000	212,18 €
Multi-range switching:	The <b>pressure ranges</b> depend on the device type and can be set via DIP switches.					
Optional:	Cable connection with <b>M12 connector</b> according to DIN EN 61076-2-101 (on request)					

**Pressure and differential pressure measuring transducers,  
including connection set, adjustable, calibratable,  
with multi-range switching and active output**

The calibratable pressure sensors **PREMASGARD® 711x** (series) with eight switchable measuring ranges (eight devices in one), housing made from impact-resistant plastic, optionally with/without display, with **cable gland** or **M12 connector** according to DIN EN 61076-2-101 and with metal pressure port nozzles (quick connect optional) are used to measure positive, negative or differential pressures in air. The piezoresistive measuring element is temperature-compensated and guarantees a high degree of reliability and accuracy.

Applications of these pressure sensors are in clean room, medical and filter technology, in ventilation and air conditioning ducts, in spray booths, in large-scale catering facilities, for filter monitoring and level measurement or for triggering frequency converters. Media measured with these pressure transducers are air (non-precipitating), or other gaseous, non-aggressive, non-combustible media.

The pressure sensor has a button for manual zero point calibration (automatic zero point calibration optional/standard for 25 Pa) and an offset potentiometer for final value correction. The sensor is factory-calibrated; an environmental precision adjustment by an expert is possible. The delivery includes the connection set **ASD-06** (2 m connection hose, two pressure port nipples, screws).

**PREMASGARD® 711x**  
with cable gland



**PREMASGARD® 711x-Q**  
with M12 connector



**Pressure port**  
Metal nozzles  
(standard)



### TECHNICAL DATA

Power supply:	24 V AC (±20%); 15...36 V DC for U variant 15...36 V DC for I variant, depending on working resistance, residual ripple stabilised ±0.3 V
Working resistance:	$R_B \text{ (Ohm)} = (U_0 - 14 \text{ V}) / 0.02 \text{ A}$ for I variant, see working resistance diagram
Load resistance:	$R_L > 5 \text{ kOhm}$ for U variant
Power consumption:	< 2 VA / 24 V DC, < 3.5 VA / 24 V AC
Measuring ranges:	<b>multi-range switching</b> <b>with 8 switchable measuring ranges</b> (see table)
Type of pressure:	differential pressure
Pressure connection:	equipped as standard with metal connection <b>nozzles</b> for pressure hose Ø 6 mm, optionally with <b>quick connect</b> made from stainless steel for PVC fabric pressure hose Ø 6 mm (external diameter)
Medium:	clean air and non-aggressive, non-combustible gases
Media temperature:	-20...+50 °C
Accuracy:	<b>Type 7112</b> (25 Pa): typically ±1 Pa <b>Type 7110</b> (100 Pa): typically ±2 Pa <b>Type 7111</b> (1000 Pa): typically ±5 Pa <b>Type 7115</b> (5000 Pa): typically ±25 Pa compared to the calibrated reference device
Sum of linearity+hysteresis:	< ±1% of final value ±2% of final value for pressure ranges < ±250 Pa
Temp. drift values:	±0.1% / °C ±0.3% / °C for pressure ranges < 250 Pa
Zero point offset:	< ±0.7% of final value ±1.4% of final value for pressure ranges < 250 Pa
Positive/negative pressure:	max. ±100 hPa
Signal filtering:	<b>switchable 1 s / 10 s</b> (via DIP switches)
Output:	0 -10 V or 4...20 mA
Connection type:	2- or 3-wire connection
Electrical connection:	0.14-1.5 mm <sup>2</sup> , via plug-in screw terminal
Cable connection:	<b>cable gland</b> , plastic (M 16 x 1.5; with strain relief, exchangeable, max. inner diameter 10.4 mm) <b>or</b> <b>M12 connector</b> (male, 5-pin, A-code) according to DIN EN 61076-2-101
Housing:	<b>plastic</b> , UV-resistant, material polyamide, 30% glass-globe reinforced, with quick-locking screws (slotted/Phillips head combination), colour traffic white (similar to RAL 9016), cover for display is transparent!
Housing dimensions:	126 x 90 x 50 mm <b>(Tyr2)</b>
Air humidity:	<95% r. H., non-precipitating air
Protection class:	III (according to EN 60 730)
Protection type:	<b>IP 65</b> (according to EN 60 529) in the built-in state
Standards:	CE conformity according to EMC Directive 2014 / 30 / EU, according to EN 61326-1, according to EN 61326-2-3
Equipment:	<b>display with illumination</b> , three-line, cutout approx. 70 x 40 mm (W x H), to display the <b>ACTUAL</b> pressure as well as the automatic zero point calibration
<b>ACCESSORIES</b>	see table



Pressure and differential pressure measuring transducers, including connection set, adjustable, calibratable, with multi-range switching and active output



Dimensional drawing PREMASGARD® 711x

Housing with **cable gland**  
equipped as standard with pressure port **nozzles**

Housing with **M12 connector**  
equipped as standard with pressure port **nozzles**

M16x1.5

M12

Pressure port **nozzles, metal**

M12 connector (male)

PREMASGARD® 711x with cable gland and display



PREMASGARD® 711x-Q with M12 connector and display



Dimensional drawing PREMASGARD® 711x

Housing with **cable gland**  
**optional** on request with **quick connect**

M16x1.5

Housing with **M12 connector**  
**optional** on request with **quick connect**

M12

Stainless steel **quick connect**

M12 connector (male)

Pressure port Stainless steel quick connect (optional)



Pressure and differential pressure measuring transducers, including connection set, adjustable, calibratable, with multi-range switching and active output

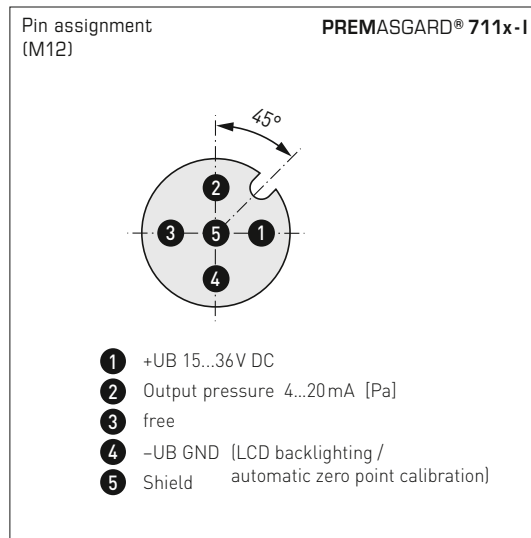
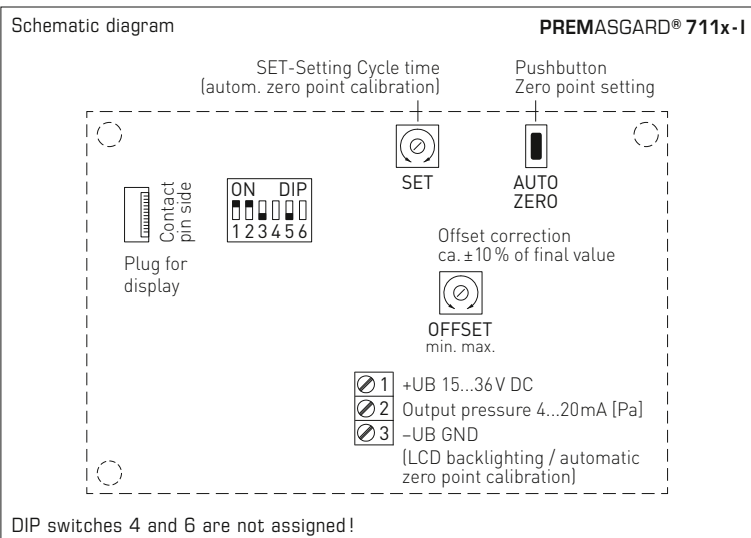
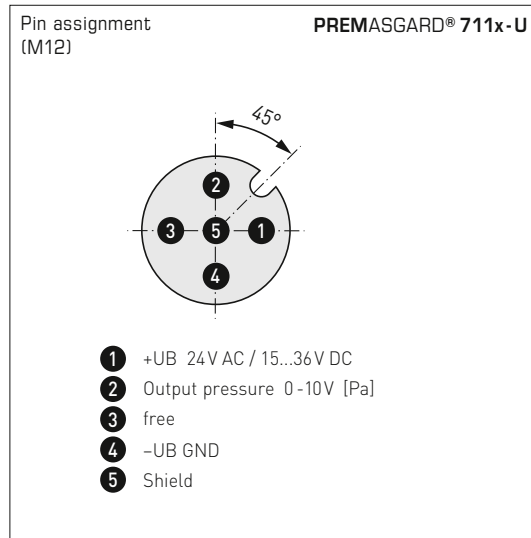
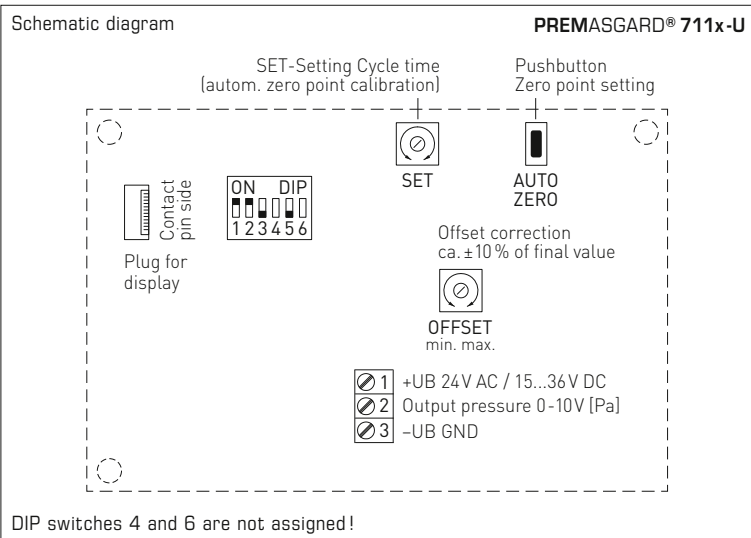

**Display with option automatic zero point calibration**

**Standard**  
Actual pressure (in Pa)  
Calibration interval (arrows)

**Zero point calibration active**  
Remaining calibration time (in seconds)

**Adjustment of zero point calibration**  
Cycle time (15 min to 24 hours) adjustable by potentiometer.

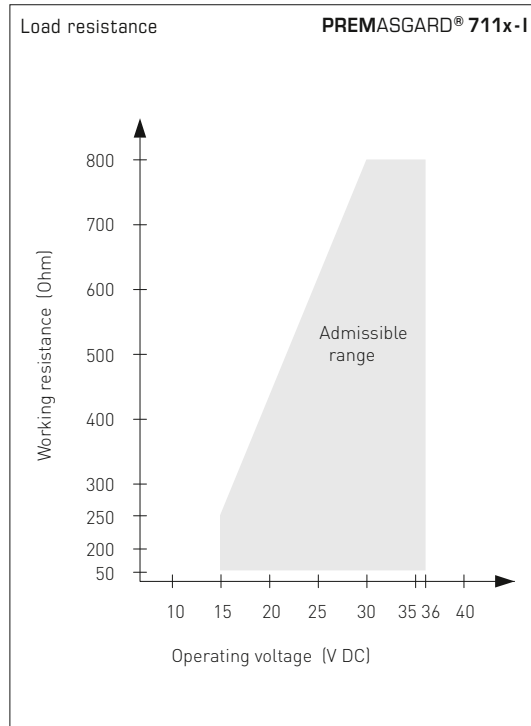



PREMASGARD® 711x-Q  
with display,  
hinged



Pressure range (selectable) – max. measuring range (default) is depending to the type of device								DIP 1	DIP 2
0...25 Pa	0...50 Pa	0...100 Pa	0...1000 Pa	-25...+25 Pa	-50...+50 Pa	-100...+100 Pa	-1000...+1000 Pa	OFF	OFF
-	-	0...300 Pa	0...2000 Pa	-	-	-300...+300 Pa	-2000...+2000 Pa	ON	OFF
-	-	0...500 Pa	0...3000 Pa	-	-	-500...+500 Pa	-3000...+3000 Pa	OFF	ON
0...25 Pa	0...100 Pa	0...1000 Pa	0...5000 Pa	-25...+25 Pa	-100...+100 Pa	-1000...+1000 Pa	-5000...+5000 Pa	ON	ON

Measuring range mode (Mode selectable)	DIP 3
Unidirectional (0...+MR) (default)	OFF
Bidirectional (-MR...+MR)	ON

Measurement signal filtering (Time interval selectable)	DIP 5
10 s (default)	OFF
1 s	ON

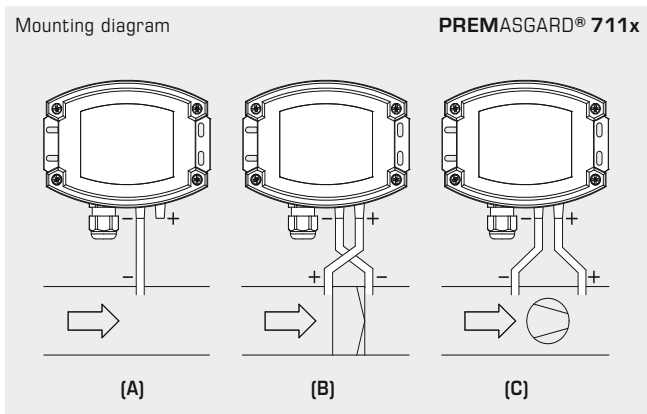

**TYPES OF MONITORING:**

**(A) Below-atmospheric pressure:**

P1 (+) is not connected  
but open against atmosphere  
P2 (-) connected to inside of duct

**(B) Filter:**

P1 (+) connected upstream of filter  
P2 (-) connected downstream of filter

**(C) Ventilator:**

P1 (+) connected downstream of ventilator  
P2 (-) connected upstream of ventilator

Pressure connections at the pressure switch are marked with P1 (+) for higher pressure and P2 (-) for lower pressure.

**Conversion table for pressure values:**

Unit =	bar	mbar	Pa	kPa	mWS
1 Pa	0,00001 bar	0,01 mbar	1 Pa	0,001 kPa	0,000101971 mWS
1 kPa	0,01 bar	10 mbar	1000 Pa	1 kPa	0,101971 mWS
1 bar	1 bar	1000 mbar	100000 Pa	100 kPa	10,1971 mWS
1 mbar	0,001 bar	1 mbar	100 Pa	0,1 kPa	0,0101971 mWS
1 mWS	0,0980665 bar	98,0665 mbar	9806,65 Pa	9,80665 kPa	1 mWS



Pressure and differential pressure measuring transducers, including connection set, adjustable, calibratable, with multi-range switching and active output

Dimensional drawing **ASD-06**  
Connection set

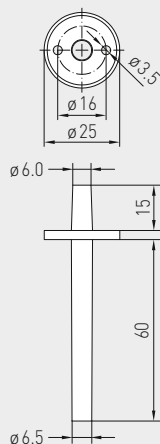

**ASD-06**  
Connection set



Dimensional drawing **ASD-07**  
Connection nipple

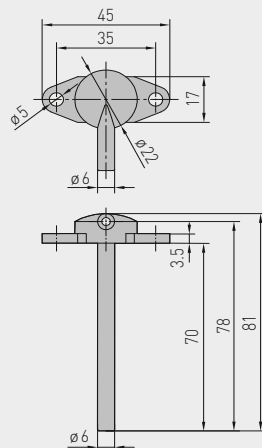

**ASD-07**  
Connection nipple



Dimensional drawing **DAL-01**  
Pressure outlet

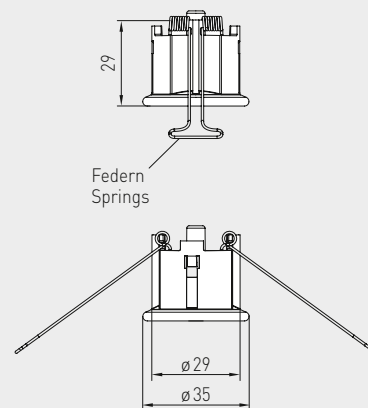

**DAL-01**  
Pressure outlet



**WS-03**  
Weather and sun protection hood (optional)

**Pressure port**  
equipped as standard with pressure port metal **nozzles**



optional on request with stainless steel **quick connect**



**ACCESSORIES**

<b>ASD-06</b>	<b>Connection set (included in the scope of delivery)</b> , consisting of 2 connection nipples (straight) made of ABS, 2 m PVC hose (soft, UV-resistant) and 4 screws	7100-0060-3000-000	<b>7,28 €</b>
<b>ASD-07</b>	<b>2 connection nipples</b> (at 90 degree angle) made of plastic, ABS	7100-0060-7000-000	<b>7,28 €</b>
<b>DAL-01</b>	<b>Pressure outlet</b> for ceiling or in-wall installation (e.g. in clean rooms)	7300-0060-3000-001	<b>34,07 €</b>
<b>WS-03</b>	<b>Weather and sun protection hood</b> , 200 x 180 x 150 mm, stainless steel <b>V2A</b> (1.4301)	7100-0040-6000-000	<b>42,61 €</b>

For further information, see chapter Accessories!



S+S REGELTECHNIK

PREMASGARD® 711x

Pressure and differential pressure measuring transducers, including connection set, adjustable, calibratable, with multi-range switching and active output

PREMASGARD® 711x-Q  
with M12 connector



PREMASGARD® 711x  
with cable gland



PREMASGARD® 711x		Pressure and differential pressure measuring transducers, <i>Deluxe</i>			
Pressure range (adjustable)	Type / WG02	Output	Display ● = Q	Item No.	Price
<b>max. - 1000...+ 1000 Pa</b>		<b>Type 7111</b>			
0... 100 Pa / - 100... + 100 Pa	PREMASGARD 7111-U	0-10V		1301-7111-0010-200	160,09 €
0... 300 Pa / - 300... + 300 Pa	PREMASGARD 7111-U LCD	0-10V	■	1301-7111-4010-200	224,59 €
0... 500 Pa / - 500... + 500 Pa	PREMASGARD 7111-I	4...20mA		1301-7112-0010-100	160,09 €
0... 1000 Pa / -1000... + 1000 Pa	PREMASGARD 7111-I LCD	4...20mA	■	1301-7112-4010-100	224,59 €
	PREMASGARD 7111-U Q	0-10V	●	2004-6131-1100-001	200,02 €
	PREMASGARD 7111-U Q LCD	0-10V	● ■	2004-6132-1100-001	264,51 €
	PREMASGARD 7111-I Q	4...20mA	●	2004-6131-2100-001	200,02 €
	PREMASGARD 7111-I Q LCD	4...20mA	● ■	2004-6132-2100-001	264,51 €
<b>max. - 5000...+ 5000 Pa</b>		<b>Type 7115</b>			
0... 1000 Pa / - 1000... + 1000 Pa	PREMASGARD 7115-U	0-10V		1301-7111-0050-200	160,09 €
0... 2000 Pa / - 2000... + 2000 Pa	PREMASGARD 7115-U LCD	0-10V	■	1301-7111-4050-200	224,59 €
0... 3000 Pa / - 3000... + 3000 Pa	PREMASGARD 7115-I	4...20mA		1301-7112-0050-100	160,09 €
0... 5000 Pa / - 5000... + 5000 Pa	PREMASGARD 7115-I LCD	4...20mA	■	1301-7112-4050-100	224,59 €
	PREMASGARD 7115-U Q	0-10V	●	2004-6131-1100-011	200,02 €
	PREMASGARD 7115-U Q LCD	0-10V	● ■	2004-6132-1100-021	264,51 €
	PREMASGARD 7115-I Q	4...20mA	●	2004-6131-2100-011	200,02 €
	PREMASGARD 7115-I Q LCD	4...20mA	● ■	2004-6132-2100-011	264,51 €
<b>max. - 100...+ 100 Pa</b>		<b>Type 7110</b>			
0... +50 Pa / -50... +50 Pa	PREMASGARD 7110-U	0-10V		1301-7111-0110-200	201,55 €
0...+100 Pa / -100...+100 Pa	PREMASGARD 7110-U LCD	0-10V	■	1301-7111-4110-200	259,14 €
	PREMASGARD 7110-I	4...20mA		1301-7112-0110-100	201,55 €
	PREMASGARD 7110-I LCD	4...20mA	■	1301-7112-4110-100	259,14 €
	PREMASGARD 7110-U Q	0-10V	●	2004-6131-1100-021	241,48 €
	PREMASGARD 7110-U Q LCD	0-10V	● ■	2004-6132-1100-031	299,06 €
	PREMASGARD 7110-I Q	4...20mA	●	2004-6131-2100-021	241,48 €
	PREMASGARD 7110-I Q LCD	4...20mA	● ■	2004-6132-2100-021	299,06 €
<b>max. - 25...+ 25 Pa</b>		<b>Type 7112</b>			
0... +25 Pa / -25... +25 Pa	PREMASGARD 7112-U	0-10V		1301-7111-0370-200	257,98 €
	PREMASGARD 7112-U LCD	0-10V	■	1301-7111-4370-200	305,45 €
	PREMASGARD 7112-I	4...20mA		1301-7112-0370-200	257,98 €
	PREMASGARD 7112-I LCD	4...20mA	■	1301-7112-4370-200	305,45 €
	PREMASGARD 7112-U Q	0-10V	●	2004-6131-1100-031	297,92 €
	PREMASGARD 7112-U Q LCD	0-10V	● ■	2004-6132-1100-011	345,37 €
	PREMASGARD 7112-I Q	4...20mA	●	2004-6131-3100-001	297,92 €
	PREMASGARD 7112-I Q LCD	4...20mA	● ■	2004-6132-3100-011	345,37 €
<b>Housing variant "Q":</b>	Cable connection with <b>M12 connector</b> (male, <b>5-pin</b> , A-code)				
<b>Multi-range switching:</b>	The <b>pressure ranges</b> depend on the device type and can be set via DIP switches.				
<b>Extra charge:</b>	Other special measuring ranges up to max. 5000 Pa <b>with optional automatic zero point calibration</b> <b>with optional quick connect</b> for PVC fabric pressure hose Ø 6 mm				47,46 € 69,10 € 39,94 €

**Pressure and differential pressure measuring transducers, adjustable, calibratable, with multi-range switching and active output**

The calibratable pressure sensors **PREMASGARD® 711x-VA** (series) with eight switchable measuring ranges (eight devices in one), **stainless steel V4A** housing, optionally with /without display, with **cable gland** or **M12 connector** according to DIN EN 61076-2-101 and pressure port by stainless steel quick connection (pipe fitting optional) are used to measure positive, negative or differential pressures in air. The piezoresistive measuring element is temperature-compensated and guarantees a high degree of reliability and accuracy.

Applications of these pressure sensors are in clean room, medical and filter technology, in ventilation and air conditioning ducts, in spray booths, in large-scale catering facilities, for filter monitoring and level measurement or for triggering frequency converters. Media measured with these pressure transducers are air (non-precipitating), or other gaseous, non-aggressive, non-combustible media.

The pressure sensor has a button for manual zero point calibration (automatic zero point calibration optional/standard for 25 Pa) and an offset potentiometer for final value correction. The sensor is factory-calibrated; an environmental precision adjustment by an expert is possible.

**PREMASGARD® 711x-VA**  
with cable gland



**PREMASGARD® 711x-VAQ**  
with M12 connector



**Pressure port**  
Stainless steel quick connect (standard)



**TECHNICAL DATA**

Power supply:	24 V AC (±20%); 15...36 V DC for U variant 15...36 V DC for I variant, depending on working resistance, residual ripple stabilised ±0.3V
Working resistance:	$R_a(\text{Ohm}) = (U_b - 14 \text{ V}) / 0.02 \text{ A}$ for I variant, see working resistance diagram
Load resistance:	$R_L > 5 \text{ kOhm}$ for U variant
Power consumption:	< 2 VA / 24 V DC, < 3.5 VA / 24 V AC
Measuring ranges:	<b>multi-range switching</b> <b>with 8 switchable measuring ranges</b> (see table)
Type of pressure:	differential pressure
Pressure port:	equipped as standard with <b>quick connect</b> made from stainless steel for PVC-fabric pressure hose Ø 6 mm (external diameter) optionally with <b>pipe fitting</b> , stainless steel V2A (1.4305) for pressure lines Ø 6 mm
Medium:	clean air and non-aggressive, non-combustible gases
Media temperature:	-20...+50 °C
Accuracy:	<b>Type 7112</b> (25 Pa): typically ± 1 Pa <b>Type 7110</b> (100 Pa): typically ± 2 Pa <b>Type 7111</b> (1000 Pa): typically ± 5 Pa <b>Type 7115</b> (5000 Pa): typically ± 25 Pa compared to the calibrated reference device
Sum of linearity+hysteresis:	< ± 1 % of final value ± 2 % of final value for pressure ranges < ± 250 Pa
Temp. drift values:	± 0.1 % / °C ± 0.3 % / °C for pressure ranges < 250 Pa
Zero point offset:	< ± 0.7 % of final value ± 1.4 % of final value for pressure ranges < 250 Pa
Positive /negative pressure:	max. ± 100 hPa
Signal filtering:	<b>switchable 1 s / 10 s</b> (via DIP switches)
Output:	0 -10 V or 4...20 mA
Connection type:	2- or 3-wire connection
Electrical connection:	0.14 -1.5 mm², via plug-in screw terminal
Cable connection:	<b>cable gland, stainless steel V2A</b> (1.4305) (M20 x 1.5; with strain relief, exchangeable, inner diameter 6 - 12 mm) <b>or</b> <b>M12 connector</b> (male, 5-pin, A-code) according to DIN EN 61076-2-101
Housing:	<b>stainless steel V4A</b> (1.4571), with non-distortion cover bolting, impact-resistant, high EMI shielding, corrosion, temperature, weather- and UV-resistant
Housing dimensions:	143 x 97 x 61 mm (Tyr 2E)
Air humidity:	<95 % r. H., non-precipitating air
Protection class:	III (according to EN 60 730)
Protection type:	<b>IP 65</b> (according to EN 60 529) in the built-in state Housing tested, TÜV SÜD, Report No. 713160960B (Skadi2)
Standards:	CE conformity according to EMC Directive 2014 / 30 / EU, according to EN 61326-1, according to EN 61326-2-3
Equipment:	<b>display with illumination</b> , three-line, cutout approx. 70 x 40 mm (W x H), to display the <b>ACTUAL</b> pressure as well as the automatic zero point calibration
<b>ACCESSORIES</b>	(see table)



Dimensional drawing

PREMASGARD® 711x-VA

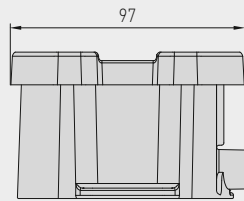
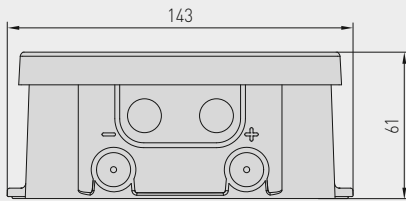

Housing with cable gland equipped as standard with quick connect for pressure hoses

Housing with M12 connector equipped as standard with quick connect for pressure hoses

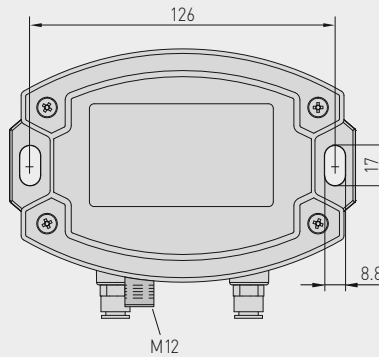
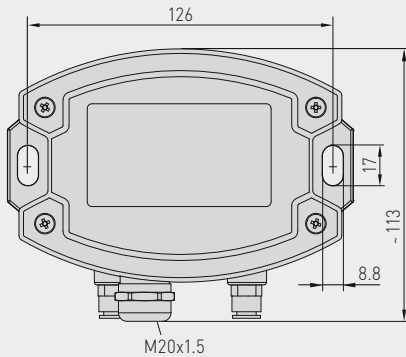

Stainless steel quick connect



M12 connector (male)

PREMASGARD® 711x-VA with cable gland and display



PREMASGARD® 711x-VAQ with M12 connector and display



Dimensional drawing

PREMASGARD® 711x-VA

Housing with cable gland optional on request with pipe fitting for pressure lines

Housing with M12 connector optional on request with pipe fitting for pressure lines

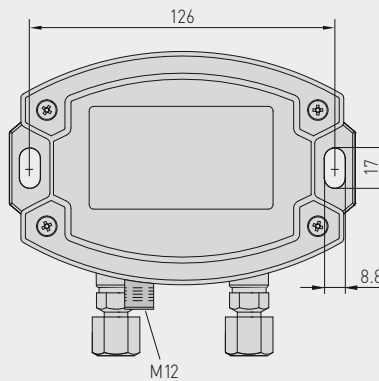
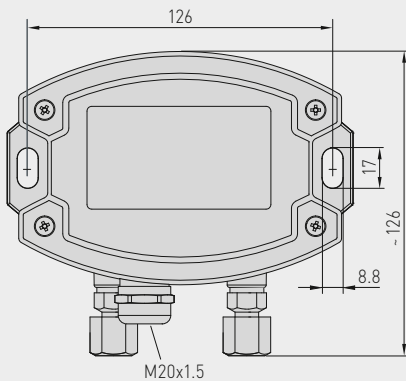

Stainless steel V2A pipe fitting



M12 connector (male)



Pressure port Stainless steel V2A pipe fitting (optional)



Pressure and differential pressure measuring transducers,  
adjustable, calibratable,  
with multi-range switching and active output

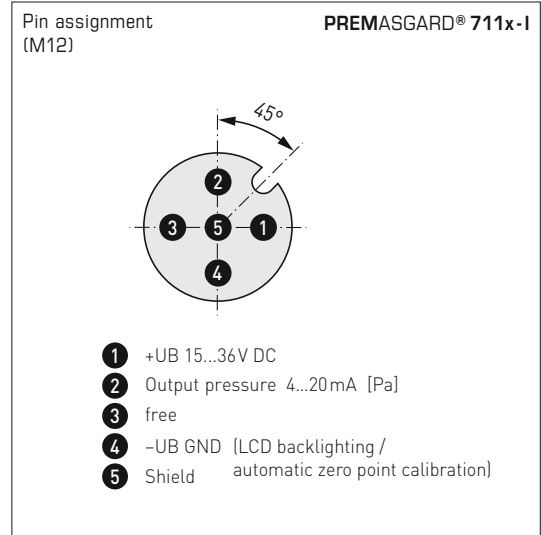
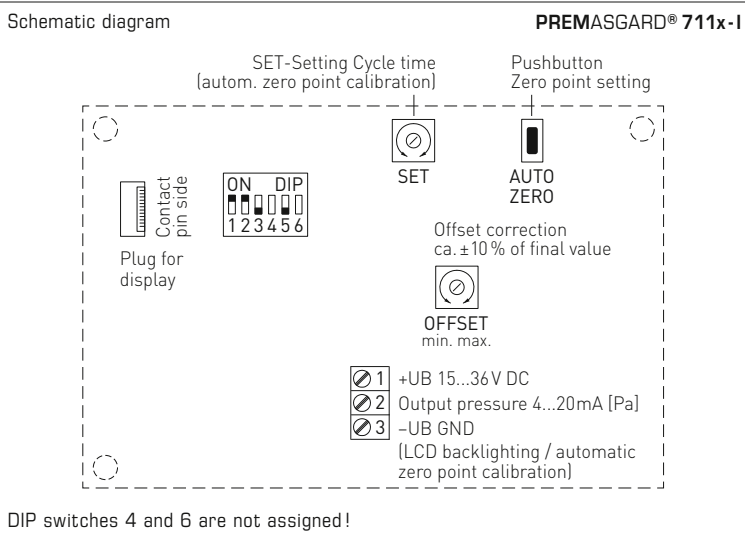
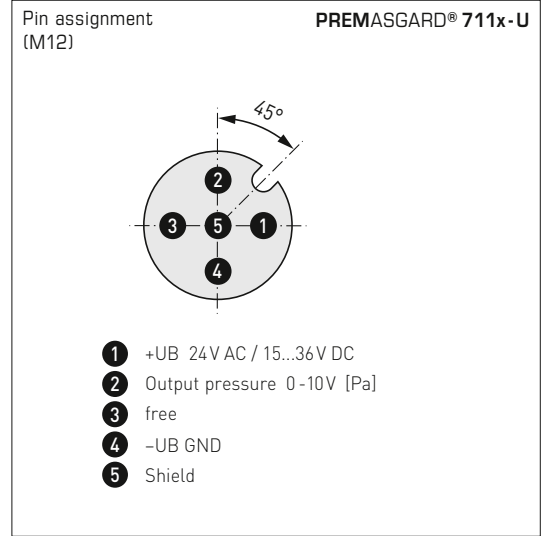
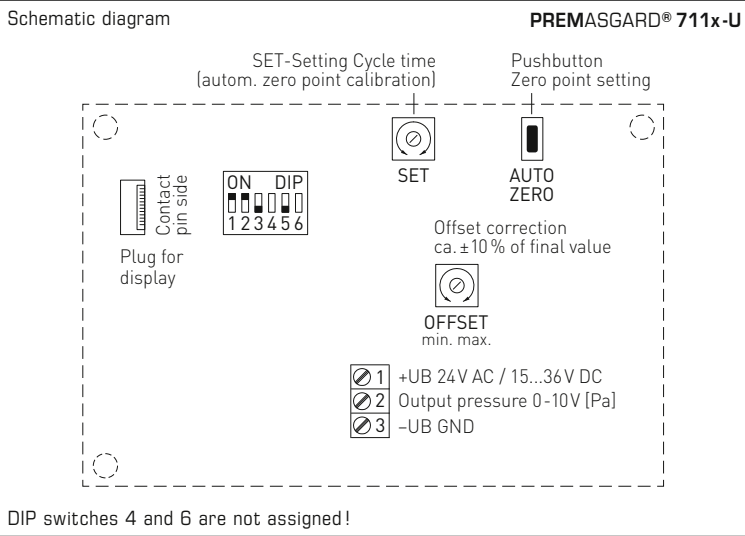

**Display with option automatic zero point calibration**

**Standard**  
Actual pressure (in Pa)  
Calibration interval (arrows)

**Zero point calibration active**  
Remaining calibration time (in seconds)

**Adjustment of zero point calibration**  
Cycle time (15 min to 24 hours) adjustable by potentiometer.

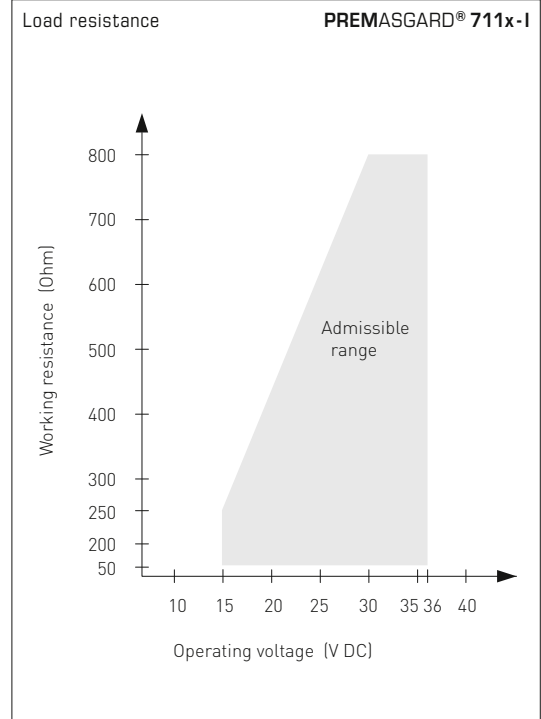





PREMASGARD® 711x-VAQ  
with display,  
hinged



Pressure range (selectable) – max. measuring range (default) is depending to the type of device								DIP 1	DIP 2
0...25 Pa	0...50 Pa	0...100 Pa	0...1000 Pa	-25...+25 Pa	-50...+50 Pa	-100...+100 Pa	-1000...+1000 Pa	OFF	OFF
-	-	0...300 Pa	0...2000 Pa	-	-	-300...+300 Pa	-2000...+2000 Pa	ON	OFF
-	-	0...500 Pa	0...3000 Pa	-	-	-500...+500 Pa	-3000...+3000 Pa	OFF	ON
0...25 Pa	0...100 Pa	0...1000 Pa	0...5000 Pa	-25...+25 Pa	-100...+100 Pa	-1000...+1000 Pa	-5000...+5000 Pa	ON	ON

Measuring range mode (Mode selectable)	DIP 3
Unidirectional (0...+MR) (default)	OFF
Bidirectional (-MR...+MR)	ON

Measurement signal filtering (Time interval selectable)	DIP 5
10 s (default)	OFF
1 s	ON

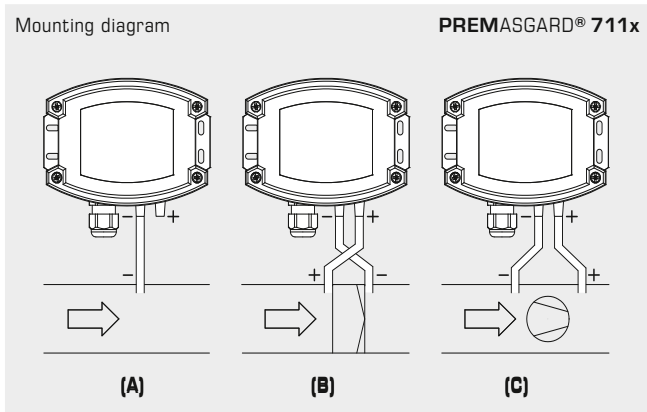

**TYPES OF MONITORING:**

- (A) Below-atmospheric pressure:**  
P1 (+) is not connected  
but open against atmosphere  
P2 (-) connected to inside of duct
- (B) Filter:**  
P1 (+) connected upstream of filter  
P2 (-) connected downstream of filter
- (C) Ventilator:**  
P1 (+) connected downstream of ventilator  
P2 (-) connected upstream of ventilator

Pressure connections at the pressure switch are marked with P1 (+) for higher pressure and P2 (-) for lower pressure.

**Conversion table for pressure values:**

Unit =	bar	mbar	Pa	kPa	mWS
1 Pa	0,00001 bar	0,01 mbar	1 Pa	0,001 kPa	0,000101971 mWS
1 kPa	0,01 bar	10 mbar	1000 Pa	1 kPa	0,101971 mWS
1 bar	1 bar	1000 mbar	100000 Pa	100 kPa	10,1971 mWS
1 mbar	0,001 bar	1 mbar	100 Pa	0,1 kPa	0,0101971 mWS
1 mWS	0,0980665 bar	98,0665 mbar	9806,65 Pa	9,80665 kPa	1 mWS

Pressure and differential pressure measuring transducers,  
adjustable, calibratable,  
with multi-range switching and active output

PREMASGARD® 711x-VAQ  
with M12 connector



PREMASGARD® 711x-VAQ		Pressure and differential pressure measuring transducer, ID Stainless steel housing with M12 connector			
Pressure range (adjustable)	Type / WG02I	Output	Display ● = Q	Item No.	Price
<b>max. - 1000...+ 1000 Pa</b>		<b>Type 7111</b>			
0... 100 Pa / - 100... + 100 Pa	PREMASGARD 7111-U VAQ	0-10 V	●	2004-6191-1100-001	532,13 €
0... 300 Pa / - 300... + 300 Pa	PREMASGARD 7111-U VAQ LCD	0-10 V	● ■	2004-6192-1100-001	704,96 €
0... 500 Pa / - 500... + 500 Pa	PREMASGARD 7111-I VAQ	4...20mA	●	2004-6191-2100-001	532,13 €
0... 1000 Pa / -1000... + 1000 Pa	PREMASGARD 7111-I VAQ LCD	4...20mA	● ■	2004-6192-2100-001	704,96 €
<b>max. - 5000...+ 5000 Pa</b>		<b>Type 7115</b>			
0... 1000 Pa / - 1000... + 1000 Pa	PREMASGARD 7115-U VAQ	0-10 V	●	2004-6191-1100-011	532,13 €
0... 2000 Pa / - 2000... + 2000 Pa	PREMASGARD 7115-U VAQ LCD	0-10 V	● ■	2004-6192-1100-011	704,96 €
0... 3000 Pa / - 3000... + 3000 Pa	PREMASGARD 7115-I VAQ	4...20mA	●	2004-6191-2100-011	532,13 €
0... 5000 Pa / - 5000... + 5000 Pa	PREMASGARD 7115-I VAQ LCD	4...20mA	● ■	2004-6192-2100-011	704,96 €
<b>max. - 100...+ 100 Pa</b>		<b>Type 7110</b>			
0... +50 Pa / -50... +50 Pa	PREMASGARD 7110-U VAQ	0-10 V	●	2004-6191-1100-021	591,51 €
0...+100 Pa / -100...+100 Pa	PREMASGARD 7110-U VAQ LCD	0-10 V	● ■	2004-6192-1100-021	756,79 €
	PREMASGARD 7110-I VAQ	4...20mA	●	2004-6191-2100-021	591,51 €
	PREMASGARD 7110-I VAQ LCD	4...20mA	● ■	2004-6192-2100-021	756,79 €
<b>max. - 25...+ 25 Pa</b>		<b>Type 7112</b>			
0... +25 Pa / -25... +25 Pa	PREMASGARD 7112-U VAQ	0-10 V	●	2004-6191-1100-031	676,16 €
<i>equipped as standard with automatic zero point calibration (3-wire connection)</i>	PREMASGARD 7112-U VAQ LCD	0-10 V	● ■	2004-6192-1100-031	826,24 €
	PREMASGARD 7112-I VAQ	4...20mA	●	2004-6191-3100-001	676,16 €
	PREMASGARD 7112-I VAQ LCD	4...20mA	● ■	2004-6192-3100-001	826,24 €
<b>Housing variant "Q":</b>	Cable connection with <b>M12 connector</b> (male, 5-pin, A-code)				
Multi-range switching:	The <b>pressure ranges</b> depend on the device type and can be set via DIP switches.				
Extra charge:	Other special measuring ranges up to max. 5000 Pa <b>with optional automatic zero point calibration</b> 47,46 € <b>with optional pipe fitting</b> made from stainless steel V2A 69,10 € for pressure lines Ø 6 mm 39,94 €				

ACCESSORIES

xx-M12 Special accessories for M12 connector

For further information, see chapter Accessories!



S+S REGELTECHNIK

Pressure and differential pressure measuring transducers,  
adjustable, calibratable,  
with multi-range switching and active output

PREMASGARD® 711x-VA  
with cable gland



PREMASGARD® 711x-VA		Pressure and differential pressure measuring transducer, ID Stainless steel housing with cable gland			
Pressure range (adjustable)	Type / WG02I	Output	Display	Item No.	Price
<b>max. - 1000...+ 1000 Pa</b>		<b>Type 7111</b>			
0... 100 Pa / - 100... + 100 Pa	PREMASGARD 7111-U VA	0-10V		2004-6191-1200-001	498,26 €
0... 300 Pa / - 300... + 300 Pa	PREMASGARD 7111-U VA LCD	0-10V	■	2004-6192-1200-001	668,26 €
0... 500 Pa / - 500... + 500 Pa	PREMASGARD 7111-I VA	4...20mA		2004-6191-2200-001	498,26 €
0... 1000 Pa / -1000... + 1000 Pa	PREMASGARD 7111-I VA LCD	4...20mA	■	2004-6192-2200-001	668,26 €
<b>max. - 5000...+ 5000 Pa</b>		<b>Type 7115</b>			
0...1000 Pa / - 1000 ... + 1000 Pa	PREMASGARD 7115-U VA	0-10V		2004-6191-1200-011	498,26 €
0...2000 Pa / -2000 ... +2000 Pa	PREMASGARD 7115-U VA LCD	0-10V	■	2004-6192-1200-011	668,26 €
0...3000 Pa / -3000 ... +3000 Pa	PREMASGARD 7115-I VA	4...20mA		2004-6191-2200-011	498,26 €
0...5000 Pa / -5000 ... +5000 Pa	PREMASGARD 7115-I VA LCD	4...20mA	■	2004-6192-2200-011	668,26 €
<b>max. - 100...+ 100 Pa</b>		<b>Type 7110</b>			
0... +50 Pa / -50... +50 Pa	PREMASGARD 7110-U VA	0-10V		2004-6191-1200-021	554,80 €
0...+100 Pa / -100...+100 Pa	PREMASGARD 7110-U VA LCD	0-10V	■	2004-6192-1200-021	720,08 €
	PREMASGARD 7110-I VA	4...20mA		2004-6191-2200-021	554,80 €
	PREMASGARD 7110-I VA LCD	4...20mA	■	2004-6192-2200-021	720,08 €
<b>max. - 25...+ 25 Pa</b>		<b>Type 7112</b>			
0... +25 Pa / -25... +25 Pa	PREMASGARD 7112-U VA	0-10V		2004-6191-1200-031	639,46 €
<i>equipped as standard with automatic zero point calibration (3-wire connection)</i>	PREMASGARD 7112-U VA LCD	0-10V	■	2004-6192-1200-031	789,54 €
	PREMASGARD 7112-I VA	4...20mA		2004-6191-3200-001	639,46 €
	PREMASGARD 7112-I VA LCD	4...20mA	■	2004-6192-3200-001	789,54 €
<b>Housing variant:</b>	Cable connection with <b>cable gland</b> made from stainless steel V2A (1.4305)				
<b>Multi-range switching:</b>	The <b>pressure ranges</b> depend on the device type and can be set via DIP switches.				
<b>Extra charge:</b>	Other special measuring ranges up to max. 5000 Pa <b>with optional automatic zero point calibration</b> <b>with optional pipe fitting</b> made from stainless steel V2A for pressure lines Ø 6 mm				47,46 € 69,10 € 39,94 €



**Pressure port**  
equipped as standard with  
**quick connect**  
for pressure hoses



optional on request  
with **pipe fitting**  
for pressure lines

Dual pressure sensor (2 measuring channels), pressure and differential pressure measuring transducer, incl. connection set, calibratable, with multi-range switching and active output (Automatic Output Switching)

**Patented quality product (patent no. DE 10 2015 015 941 B4)**

Calibratable dual pressure sensor **PREMASGARD® 722x** (series) with 2 x 8 switchable measuring ranges, 2 automated output signals (32 devices in one), housing with pressure connection nozzle from impact-resistant plastic, optionally with/without display, with cable gland or M12 connector acc. to DIN EN 61076-2-101 for measuring overpressure, underpressure or differential pressure of the air. The pressure measuring transducer automatically detects the required output type and converts the measurands into the required standard signal of 0-10 V or 4...20 mA (**Automatic Output Switching**).

It is used in the clean room, medical and filter technology, ventilation and air conditioning ducts, spray booths, large-scale catering facilities, for filter monitoring and level measurement or for triggering frequency converters. Media measured with this pressure measuring transducer are clean air (non-precipitating), or other gaseous, non-aggressive, non-combustible media.

Both pressure sensors with piezoresistive measuring element are temperature-compensated and guarantee a high level of reliability and accuracy. The device has a push-button for manual zero point matching as well as an offset potentiometer for correcting the final value. The sensor is factory-calibrated; an environmental precision adjustment by an expert is possible. The delivery includes a connection set **ASD-06** (2 m connection hose, two pressure connection nipples, screws).

**PREMASGARD® 722x**  
with cable gland



**PREMASGARD® 722x-Q**  
with M12 connector



**Dual pressure connection**  
Housing with cable gland



**TECHNICAL DATA**

Power supply:	24 V AC/DC (± 10%)
Working resistance:	$R_a$ (ohms) = 25...450 Ohm (at I output)
Load resistance:	$R_L > 15$ kOhm (at U output)
Power consumption:	< 2 W / 24 V DC; < 4.4 VA / 24 V AC
Pressure type:	differential pressure ( <b>2 measuring channels</b> )
Measuring ranges:	<b>Multi-range switching</b> <b>with 2 x 8 switchable measuring ranges</b> (see table)
Accuracy:	<b>Type 7229</b> (500 Pa): typical ± 13 Pa <b>Type 722x</b> (7000 Pa): typical ± 105 Pa compared to a calibrated reference device
Pressure connection:	with connection nozzle for pressure hose Ø 6 mm
Medium:	clean air and non-aggressive, non-combustible gases
Media temperature:	-20...+50 °C (temperature-compensated 0...+50 °C)
Temp. drift values:	± 0.1 % / °C final value
Zero point offset:	± 10 % measuring range
Above- / below-pressure:	± 50 kPa
Signal filtering:	<b>switchable 1 s / 10 s</b> (via DIP switch)
Output:	<b>automatically 0-10 V / 4...20 mA</b> (via <b>Automatic Output Switching</b> – the device detects the required output type and automatically switches to U or I output)
Switching type:	3-wire connection
electrical connection:	0.2–1.5 mm <sup>2</sup> , via push-in clamp
Cable connection:	<b>cable gland</b> from plastic (M 16 x 1.5; with strain relief, exchangeable, max. inner diameter 10.4 mm) <b>or</b> <b>M12 connector</b> (male, 5-pin, A-code) according to DIN EN 61076-2-101
Housing:	plastic, UV-resistant, polyamide material, 30 % glass-globe reinforced, with quick-locking screws (slotted / Philips head combination), colour traffic white (similar to RAL 9016), housing cover for display is transparent!
Housing dimensions:	126 x 90 x 50 mm (Tyr 2)
Humidity:	< 95 % r.H., non-precipitating air
Protection class:	III (according to EN 60730)
Safety class:	<b>IP 65</b> (according to EN 60529) in the built-in state
Standards:	CE conformity, electro-magnetic compatibility according to EN 61326, EMC Directive 2014 / 30 / EU
Features:	<b>Illuminated display</b> , 3 lines, cut-out approx. 70 x 40 mm (W x H), to display the <b>ACTUAL</b> pressure of both channels (cyclical)
<b>ACCESSORIES</b>	see table



**NEW**

S+S REGELTECHNIK

PREMASGARD® 722x

Dual pressure sensor (2 measuring channels),  
pressure and differential pressure measuring transducer,  
incl. connection set, calibratable, with multi-range switching  
and active output (Automatic Output Switching)



Dimensional drawing

PREMASGARD® 722x

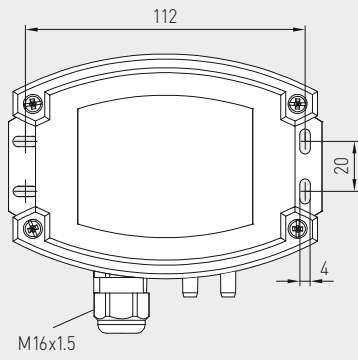
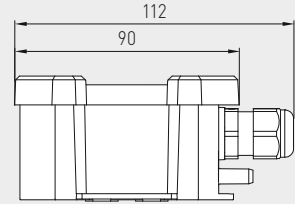
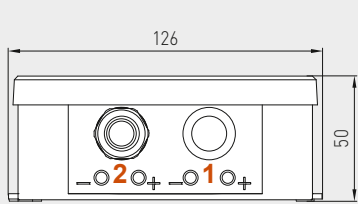

Housing with  
dual pressure connection  
(2 measuring channels)  
and cable gland

PREMASGARD® 722x  
with cable gland  
and display



PREMASGARD® 722x-Q  
with M12 connector  
and display

Dimensional drawing

PREMASGARD® 722x-Q

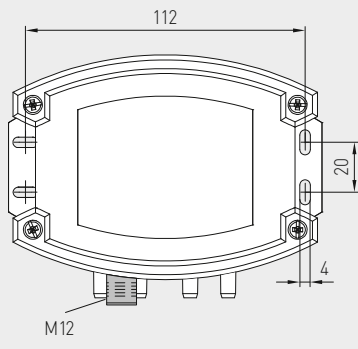
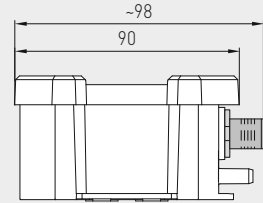
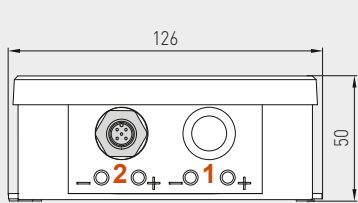

Housing with  
dual pressure connection  
(2 measuring channels)  
and M12 connector  
(male)

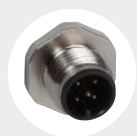

Dual pressure connection  
Housing with  
M12 connector



Automatic detection and switching  
to standard signal 0...10V or 4...20 mA

**AOS-PATENTED**  
AUTOMATIC OUTPUT SWITCHING



Dual pressure sensor (2 measuring channels),  
pressure and differential pressure measuring transducer,  
incl. connection set, calibratable, with multi-range switching  
and active output (Automatic Output Switching)

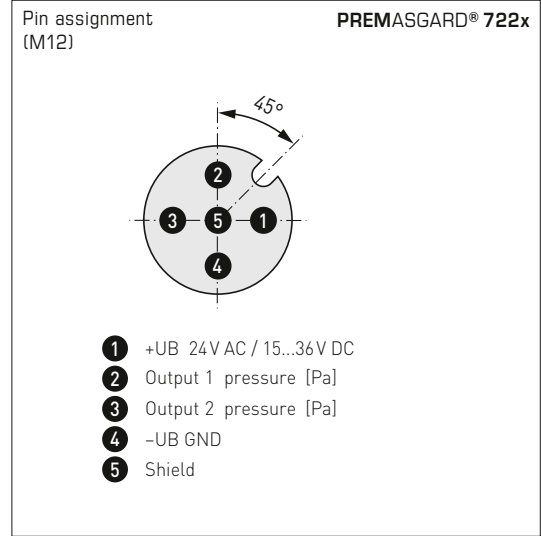
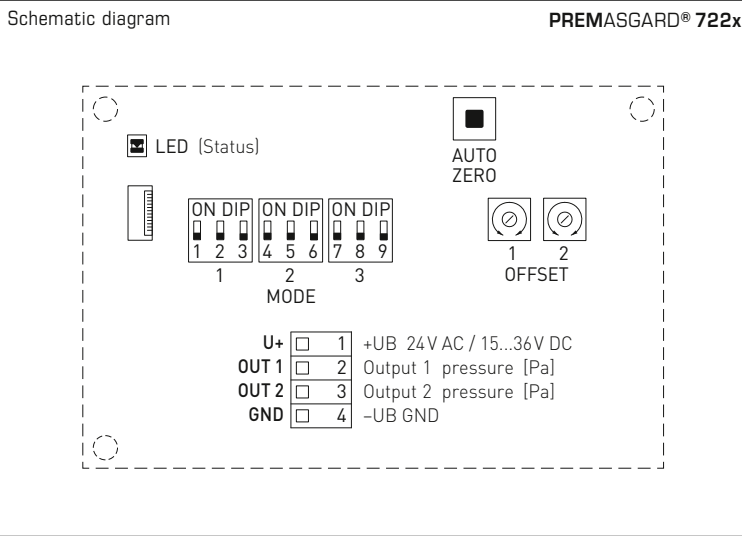

Measuring channel 1 Pressure range				
Type 7227 adjustable	Type 7229 adjustable	DIP 1	DIP 2	DIP 3
0...+1000 Pa	0...+100 Pa	OFF	OFF	OFF
0...+3000 Pa	0...+200 Pa	ON	OFF	OFF
0...+5000 Pa	0...+300 Pa	OFF	ON	OFF
0...+7000 Pa	0...+500 Pa	ON	ON	OFF
-1000...+1000 Pa	-100...+100 Pa	OFF	OFF	ON
-3000...+3000 Pa	-200...+200 Pa	ON	OFF	ON
-5000...+5000 Pa	-300...+300 Pa	OFF	ON	ON
-7000...+7000 Pa	-500...+500 Pa	ON	ON	ON

Measuring channel 2 Pressure range			
Type 722x adjustable	DIP 4	DIP 5	DIP 6
0...+1000 Pa	OFF	OFF	OFF
0...+3000 Pa	ON	OFF	OFF
0...+5000 Pa	OFF	ON	OFF
0...+7000 Pa	ON	ON	OFF
-1000...+1000 Pa	OFF	OFF	ON
-3000...+3000 Pa	ON	OFF	ON
-5000...+5000 Pa	OFF	ON	ON
-7000...+7000 Pa	ON	ON	ON

Mode Measurement signal filtering	
Selectable time interval	DIP 7
10 s (default)	OFF
1 s	ON

Note:  
DIP 8 and 9 are not defined!

Displays **PREMASGARD® 722x**

**Default display**  
Measured value

Actual pressure [Pa] of both channels is shown cyclically (Interval approx. 6 seconds).  
The associated measuring channel is shown on the bottom left.

**Status display**  
zero point calibration

Remaining calibration time is shown (in seconds).  
Change from "AUTO 0" to "PROG 0" shows that matching was correct.

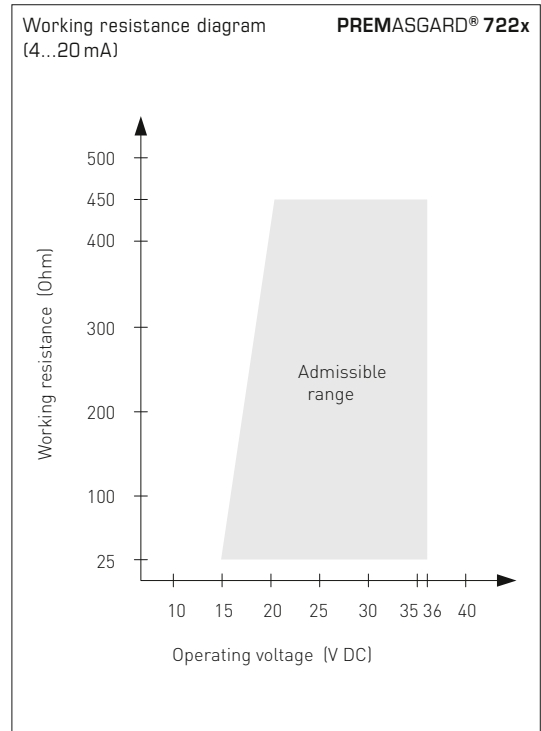



S+S REGELTECHNIK

NEW

PREMASGARD® 722x

Dual pressure sensor (2 measuring channels), pressure and differential pressure measuring transducer, incl. connection set, calibratable, with multi-range switching and active output (Automatic Output Switching)

PREMASGARD® 722x-Q  
with display,  
hinged



Mounting diagram

PREMASGARD® 722x

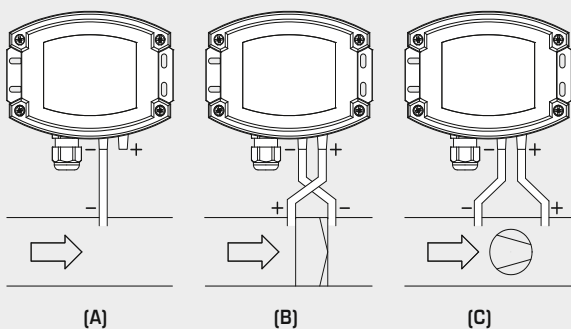

TYPES OF MONITORING:

- (A) **Below-atmospheric pressure:**  
P1 (+) is not connected  
but open against atmosphere  
P2 (-) connected to inside of duct
- (B) **Filter:**  
P1 (+) connected upstream of filter  
P2 (-) connected downstream of filter
- (C) **Ventilator:**  
P1 (+) connected downstream of ventilator  
P2 (-) connected upstream of ventilator

Pressure connections at the pressure switch are marked with P1 (+) for higher pressure and P2 (-) for lower pressure.

Conversion table for pressure values:

Unit =	bar	mbar	Pa	kPa	mWS
1 Pa	0,00001 bar	0,01 mbar	1 Pa	0,001 kPa	0,000101971 mWS
1 kPa	0,01 bar	10 mbar	1000 Pa	1 kPa	0,101971 mWS
1 bar	1 bar	1000 mbar	100000 Pa	100 kPa	10,1971 mWS
1 mbar	0,001 bar	1 mbar	100 Pa	0,1 kPa	0,0101971 mWS
1 mWS	0,0980665 bar	98,0665 mbar	9806,65 Pa	9,80665 kPa	1 mWS

Dual pressure sensor (2 measuring channels), pressure and differential pressure measuring transducer, incl. connection set, calibratable, with multi-range switching and active output (Automatic Output Switching)

Dimensional drawing ASD-06 Connection set

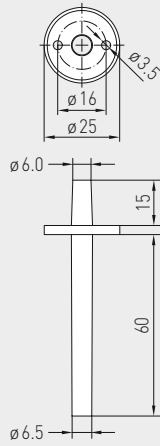

ASD-06 Connection set



Dimensional drawing ASD-07 Connection nipple

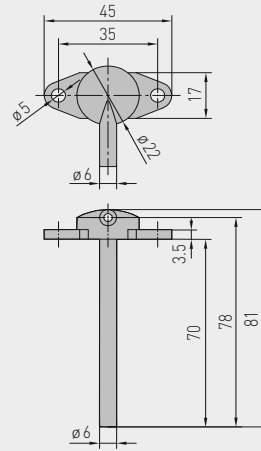

ASD-07 Connection nipple



Dimensional drawing DAL-01 Pressure outlet

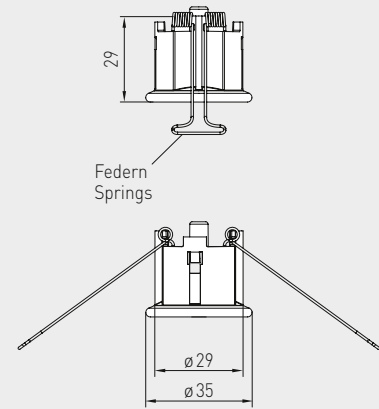

DAL-01 Pressure outlet



WS-03 Weather and sun protection hood (optional)

ACCESSORIES

ASD-06	Connection set (included in the scope of delivery), consisting of 2 connection nipples (straight) made of ABS, 2 m PVC hose (soft, UV-resistant) and 4 screws	7100-0060-3000-000	7,28 €
ASD-07	2 connection nipples (at 90 degree angle) made of plastic, ABS	7100-0060-7000-000	7,28 €
DAL-01	Pressure outlet for ceiling or in-wall installation (e.g. in clean rooms)	7300-0060-3000-001	34,07 €
WS-03	Weather and sun protection hood, 200 x 180 x 150 mm, stainless steel V2A (1.4301)	7100-0040-6000-000	42,61 €

For further information, see chapter Accessories!



S+S REGELTECHNIK

**NEW**

PREMASGARD® 722x

Dual pressure sensor (2 measuring channels),  
pressure and differential pressure measuring transducer,  
incl. connection set, calibratable, with multi-range switching  
and active output (Automatic Output Switching)

PREMASGARD® 722x-Q  
with M12 connector



PREMASGARD® 722x  
with cable gland



PREMASGARD® 722x		Dual pressure sensor (2 measuring channels), pressure and differential pressure measuring transducer, <i>Deluxe</i>			
Pressure range (adjustable per channel)	Type/WG02	Output (automatically)	Display ● = Q	Item No.	Price
<b>(1) max. - 7000...+ 7000 Pa</b> <b>(2) max. - 7000...+ 7000 Pa</b>	<b>Type 7227</b>				
Channel (1) and (2): 0 ... 1000 Pa / - 1000 ... + 1000 Pa 0 ... 3000 Pa / - 3000 ... + 3000 Pa 0 ... 5000 Pa / - 5000 ... + 5000 Pa 0 ... 7000 Pa / - 7000 ... + 7000 Pa	PREMASGARD 7227	0-10V / 4...20mA		1301-712A-0950-200	<b>218,16 €</b>
	PREMASGARD 7227 LCD	0-10V / 4...20mA	■	1301-712A-4950-200	<b>264,60 €</b>
	PREMASGARD 7227 Q	0-10V / 4...20mA	●	2004-6331-B100-011	<b>254,88 €</b>
	PREMASGARD 7227 Q LCD	0-10V / 4...20mA	● ■	2004-6332-B100-011	<b>301,32 €</b>
<b>(1) max. - 500... + 500 Pa</b> <b>(2) max. - 7000...+ 7000 Pa</b>	<b>Type 7229</b>				
Channel (1): 0 ... 100 Pa / - 100 ... + 100 Pa 0 ... 200 Pa / - 200 ... + 200 Pa 0 ... 300 Pa / - 300 ... + 300 Pa 0 ... 500 Pa / - 500 ... + 500 Pa Channel (2): see Type 7227	PREMASGARD 7229	0-10V / 4...20mA		1301-712A-0930-200	<b>218,16 €</b>
	PREMASGARD 7229 LCD	0-10V / 4...20mA	■	1301-712A-4930-200	<b>264,60 €</b>
	PREMASGARD 7229 Q	0-10V / 4...20mA	●	2004-6331-B100-001	<b>254,88 €</b>
	PREMASGARD 7229 Q LCD	0-10V / 4...20mA	● ■	2004-6332-B100-001	<b>301,32 €</b>
Multi-range switching:	The <b>pressure ranges</b> depend on the device type and for each measuring channel, they are separately adjustable via DIP switch.				
Automatic Output Switching:	Patented analogue interface (patent no. DE 10 2015 015 941 B4) Device automatically detects the required output type 0-10 V or 4...20 mA.				
Housing variant Q:	Cable connection with <b>M12 connector</b> (male, 5 pin, A-code)				

**Pressure and differential pressure measuring transducers/switches,  
incl. connection set, with multi-range switching  
and adjustable, switching and active output**

The electronic **PREMASREG® 711x** pressure sensors and switches are equipped with eight switchable measuring ranges, one switching output, one continuous output, and a display for setting the switch-point and to display the ACTUAL pressure (eight devices in one, plus differential pressure switch / differential pressure monitor, continuous pressure sensor in a single device).

The pressure sensor with a housing made from impact-resistant plastic, with **cable gland** or **M12 connector** according to DIN EN 61076-2-101 and with metal pressure port nozzles (quick connect optional) is used to measure positive, negative or differential pressures in clean air, with limit value switching. The piezoresistive measuring element guarantees a high degree of reliability and accuracy.

Applications of these pressure sensors are in clean room, medical and filter technology, in ventilation and air conditioning ducts, in spray booths, in large-scale catering facilities, for filter monitoring and level measurement or for triggering frequency converters. Media measured with these pressure transducers are air (non-precipitating), or other gaseous, non-aggressive, non-combustible media.

The pressure sensor has a button for manual zero point calibration (automatic zero point calibration optional) and one offset potentiometer for setting the switching point and one for final value correction. The sensor is factory-calibrated; an environmental precision adjustment by an expert is possible. The delivery includes the connection set **ASD-06** (2m connection hose, two pressure port nipples, screws).

### TECHNICAL DATA

Power supply:	24 V AC / DC (± 20%)
Load resistance:	$R_L > 5 \text{ k}\Omega$
Power consumption:	< 1 VA / 24 V DC, < 2.2 VA / 24 V AC
Measuring ranges:	<b>multi-range switching with 8 switchable measuring ranges</b> (see table)
Type of pressure:	differential pressure
Pressure connection:	equipped as standard with metal connection nozzles for pressure hose $\varnothing 6 \text{ mm}$ , optionally with <b>quick connect</b> made from stainless steel for PVC fabric pressure hose $\varnothing 6 \text{ mm}$ (external diameter)
Medium:	clean air and non-aggressive, non-combustible gases
Media temperature:	-20...+50 °C
Accuracy:	<b>Type 7111</b> (1000 Pa): typically ± 5 Pa <b>Type 7115</b> (5000 Pa): typically ± 25 Pa compared to the calibrated reference device
Sum of linearity+hysteresis:	< ± 1 % of final value
Temp. drift values:	± 0.1 % / °C
Zero point offset:	< ± 0.7 % of final value
Setting increment $\Delta p$ :	1 % of pressure range (100 Pa => 1 Pa; 5000 Pa => 50 Pa)
Switching hysteresis:	± 1 % of pressure range (100 Pa => ± 1 Pa; 5000 Pa => ± 50 Pa)
Positive /negative pressure:	max. ± 100 hPa
Signal filtering:	<b>switchable 1 s / 10 s</b> (via DIP switches)
Output:	0 -10 V 1 changeover contact (24 V), 1 A ohmic load
Connection type:	3-wire connection
Electrical connection:	0.14 -1.5 mm <sup>2</sup> , via plug-in screw terminal
Cable connection:	<b>cable gland</b> , plastic (M 16 x 1.5; with strain relief, exchangeable, max. inner diameter 10.4 mm) <b>or</b> <b>M12 connector</b> (male, 12-pin, A-code) according to DIN EN 61076-2-101
Housing:	<b>plastic</b> , UV-resistant, material polyamide, 30 % glass-globe reinforced, with quick-locking screws (slotted / Phillips head combination), colour traffic white (similar to RAL 9016), cover for display is transparent!
Housing dimensions:	126 x 90 x 50 mm (Tyr 2)
Air humidity:	< 95 % r. H., non-precipitating air
Protection class:	III (according to EN 60 730)
Protection type:	<b>IP 65</b> (according to EN 60 529) in the built-in state
Standards:	CE conformity according to EMC Directive 2014 / 30 / EU, according to EN 61326-1, according to EN 61326-2-3
Equipment:	<b>display with illumination</b> , three-line, cutout approx. 70 x 40 mm (W x H), for displaying ACTUAL pressure and/or SETPOINT pressure as well as automatic zero point calibration
<b>ACCESSORIES</b>	see table

**Pressure port**  
Metal nozzles  
(standard)







Pressure and differential pressure measuring transducers/switches, incl. connection set, with multi-range switching and adjustable, switching and active output



**Dimensional drawing** **PREMASREG® 711x**

**Housing with cable gland**  
equipped as standard with pressure port nozzles

**Housing with M12 connector**  
equipped as standard with pressure port nozzles

**Pressure port nozzles, metal**

**M12 connector (male)**

**PREMASREG® 711x-Q**  
with cable gland and display



**PREMASREG® 711x-Q**  
with M12 connector and display



**Pressure port**  
Stainless steel quick connect (optional)

**Dimensional drawing** **PREMASREG® 711x**

**Housing with cable gland**  
**optional on request with quick connect**

**Housing with M12 connector**  
**optional on request with quick connect**

**Stainless steel quick connect**

**M12 connector (male)**



Pressure and differential pressure measuring transducers/switches,  
incl. connection set, with multi-range switching  
and adjustable, switching and active output

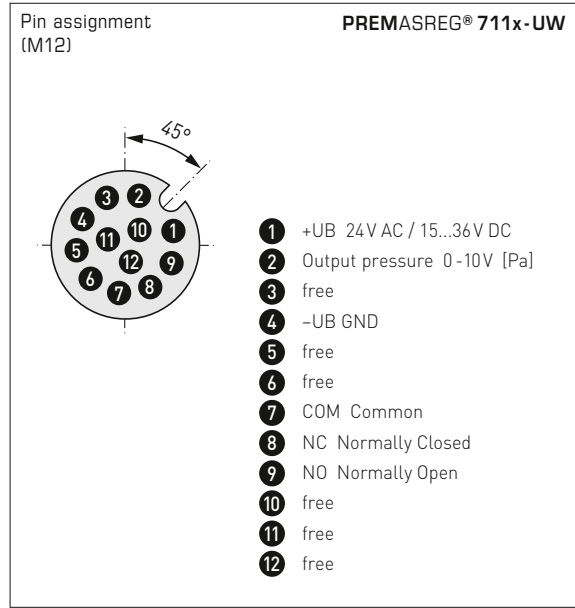
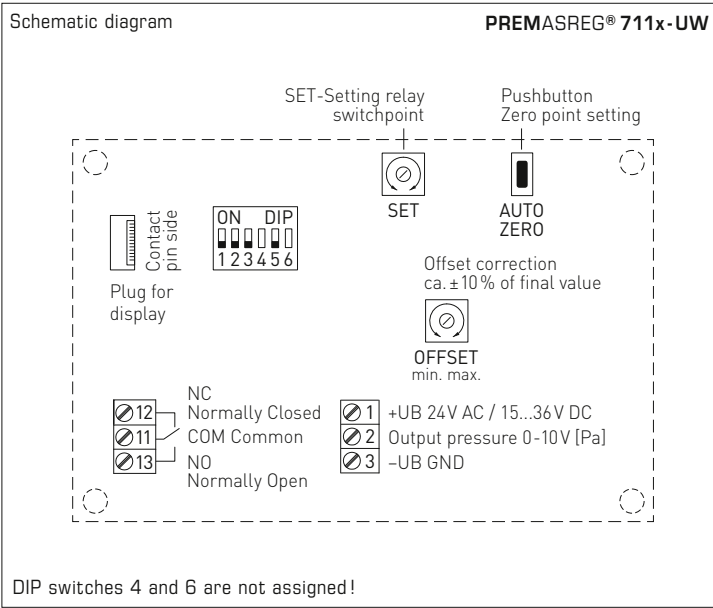

Pressure range (selectable) – max. measuring range (default) is depending to the type of device				DIP 1	DIP 2
0...100 Pa	0...1000 Pa	-100...+100 Pa	-1000...+1000 Pa	OFF	OFF
0...300 Pa	0...2000 Pa	-300...+300 Pa	-2000...+2000 Pa	ON	OFF
0...500 Pa	0...3000 Pa	-500...+500 Pa	-3000...+3000 Pa	OFF	ON
0...1000 Pa	0...5000 Pa	-1000...+1000 Pa	-5000...+5000 Pa	ON	ON

Measuring range mode (Mode selectable)	DIP 3
Unidirectional (0...+MR) (default)	OFF
Bidirectional (-MR...+MR)	ON

Measurement signal filtering (Time interval selectable)	DIP 5
10 s (default)	OFF
1 s	ON

Display with option  
automatic zero point calibration



**Zero point calibration active**

Remaining calibration time  
(in seconds)

Cycle time (approx. 90 minutes)  
is fixed in the factory.



Pressure and differential pressure measuring transducers/switches, incl. connection set, with multi-range switching and adjustable, switching and active output

PREMASREG® 711x-Q with display, hinged

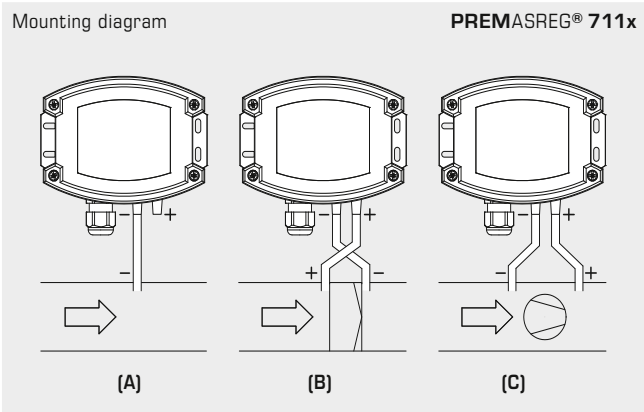

**TYPES OF MONITORING:**

- (A) Below-atmospheric pressure:**  
P1 (+) is not connected but open against atmosphere  
P2 (-) connected to inside of duct
- (B) Filter:**  
P1 (+) connected upstream of filter  
P2 (-) connected downstream of filter
- (C) Ventilator:**  
P1 (+) connected downstream of ventilator  
P2 (-) connected upstream of ventilator

Pressure connections at the pressure switch are marked with P1 (+) for higher pressure and P2 (-) for lower pressure.

**Conversion table for pressure values:**

Unit =	bar	mbar	Pa	kPa	mWS
1 Pa	0,00001 bar	0,01 mbar	1 Pa	0,001 kPa	0,000101971 mWS
1 kPa	0,01 bar	10 mbar	1000 Pa	1 kPa	0,101971 mWS
1 bar	1 bar	1000 mbar	100000 Pa	100 kPa	10,1971 mWS
1 mbar	0,001 bar	1 mbar	100 Pa	0,1 kPa	0,0101971 mWS
1 mWS	0,0980665 bar	98,0665 mbar	9806,65 Pa	9,80665 kPa	1 mWS

Pressure and differential pressure measuring transducers/switches,  
incl. connection set, with multi-range switching  
and adjustable, switching and active output

Dimensional drawing **ASD-06**  
Connection set

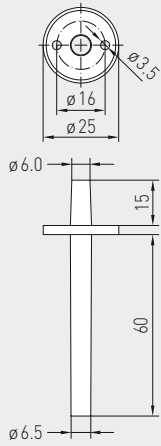

**ASD-06**  
Connection set



Dimensional drawing **ASD-07**  
Connection nipple

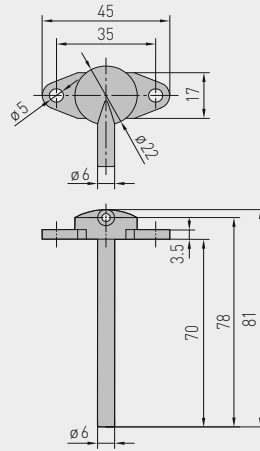

**ASD-07**  
Connection nipple



Dimensional drawing **DAL-01**  
Pressure outlet

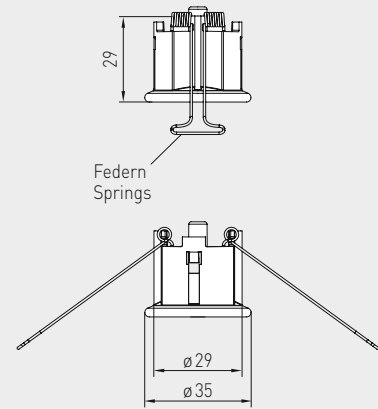

**DAL-01**  
Pressure outlet



**WS-03**  
Weather and sun protection hood  
(optional)

**Pressure port**  
equipped as standard with  
pressure port metal **nozzles**



optional on request  
with stainless steel  
**quick connect**



**ACCESSORIES**

<b>ASD-06</b>	<b>Connection set (included in the scope of delivery)</b> , consisting of 2 connection nipples (straight) made of ABS, 2 m PVC hose (soft, UV-resistant) and 4 screws	7100-0060-3000-000	<b>7,28 €</b>
<b>ASD-07</b>	<b>2 connection nipples</b> (at 90 degree angle) made of plastic, ABS	7100-0060-7000-000	<b>7,28 €</b>
<b>DAL-01</b>	<b>Pressure outlet</b> for ceiling or in-wall installation (e.g. in clean rooms)	7300-0060-3000-001	<b>34,07 €</b>
<b>WS-03</b>	<b>Weather and sun protection hood</b> , 200 x 180 x 150 mm, stainless steel <b>V2A</b> (1.4301)	7100-0040-6000-000	<b>42,61 €</b>

For further information, see chapter Accessories!



S+S REGELTECHNIK

PREMASREG® 711x

Pressure and differential pressure measuring transducers/switches,  
incl. connection set, with multi-range switching  
and adjustable, switching and active output

PREMASREG® 711x-Q  
with M12 connector



PREMASREG® 711x  
with cable gland



PREMASREG® 711x		Pressure and differential pressure measuring transducers/switches, <i>Deluxe</i> (with cable gland or M12 connector)			
Pressure range (adjustable)	Type/WG02	Output	Display ● = Q	Item No.	Price
<b>max. - 1000...+ 1000 Pa</b>		<b>Type 7111</b>			
0... 100 Pa / - 100... + 100 Pa	PREMASREG 7111-UW LCD	0-10V 1x Changeover contact	■	1302-7111-4011-200	229,19 €
0... 300 Pa / - 300... + 300 Pa	PREMASREG 7111-UW Q LCD	0-10V 1x Changeover contact	● ■	2004-6132-4100-001	269,13 €
0... 500 Pa / - 500... + 500 Pa					
0... 1000 Pa / -1000... + 1000 Pa					
<b>max. - 5000...+ 5000 Pa</b>		<b>Type 7115</b>			
0... 1000 Pa / - 1000... + 1000 Pa	PREMASREG 7115-UW LCD	0-10V 1x Changeover contact	■	1302-7111-4051-200	229,19 €
0...2000 Pa / -2000... + 2000 Pa	PREMASREG 7115-UW Q LCD	0-10V 1x Changeover contact	● ■	2004-6132-4100-011	269,13 €
0...3000 Pa / -3000... + 3000 Pa					
0...5000 Pa / -5000... + 5000 Pa					
<b>Housing variant "Q":</b>	Cable connection with <b>M12 connector</b> (male, <b>12-pin</b> , A-code)				
<b>Multi-range switching:</b>	The <b>pressure ranges</b> depend on the device type and can be set via DIP switches.				
<b>Extra charge:</b>	Other special measuring ranges up to max. 5000 Pa <b>with optional automatic zero point calibration</b> <b>with optional quick connect</b> for PVC fabric pressure hose Ø 6 mm				47,46 € 69,10 € 39,94 €



**Pressure and differential pressure measuring transducers/switches,  
with multi-range switching  
and adjustable, switching and active output**

The electronic **PREMASREG® 711x-VA** pressure sensors and switches are equipped with eight switchable measuring ranges, one switching output, one continuous output, and a display for setting the switchpoint and to display the ACTUAL pressure (eight devices in one, plus differential pressure switch/differential pressure monitor, continuous pressure sensor in a single device).

The pressure sensor with a housing made from **stainless steel V4A**, with **cable gland** or **M12 connector** according to DIN EN 61076-2-101 and with pressure port by stainless steel quick connect (pipe fitting optional) is used to measure positive, negative or differential pressures in clean air, with limit value switching. The piezoresistive measuring element guarantees a high degree of reliability and accuracy.

Applications of these pressure sensors are in clean room, medical and filter technology, in ventilation and air conditioning ducts, in spray booths, in large-scale catering facilities, for filter monitoring and level measurement or for triggering frequency converters. Media measured with these pressure transducers are air (non-precipitating), or other gaseous, non-aggressive, non-combustible media.

The pressure sensor has a button for manual zero point calibration (automatic zero point calibration optional) as well as one offset potentiometer for setting the switching point and one for final value correction. The sensor is factory-calibrated; an environmental precision adjustment by an expert is possible.

#### TECHNICAL DATA

Power supply:	24 V AC / DC (± 20 %)
Load resistance:	$R_L > 5 \text{ k}\Omega$
Power consumption:	< 1 VA / 24 V DC, < 2.2 VA / 24 V AC
Measuring ranges:	<b>multi-range switching with 8 switchable measuring ranges</b> (see table)
Type of pressure:	differential pressure
Pressure port:	equipped as standard with <b>quick connect</b> made from stainless steel for PVC-fabric pressure hose $\varnothing 6 \text{ mm}$ (external diameter) optionally with <b>pipe fitting</b> , stainless steel V2A (1.4305) for pressure lines $\varnothing 6 \text{ mm}$
Medium:	clean air and non-aggressive, non-combustible gases
Media temperature:	-20...+50 °C
Accuracy:	<b>Type 7111</b> (1000 Pa): typically ± 5 Pa <b>Type 7115</b> (5000 Pa): typically ± 25 Pa compared to the calibrated reference device
Sum of linearity+hysteresis:	< ± 1 % of final value
Temp. drift values:	± 0.1 % / °C
Zero point offset:	< ± 0.7 % of final value
Setting increment $\Delta p$ :	1 % of pressure range (100 Pa => 1 Pa; 5000 Pa => 50 Pa)
Switching hysteresis:	± 1 % of pressure range (100 Pa => ± 1 Pa; 5000 Pa => ± 50 Pa)
Positive/negative pressure:	max. ± 100 hPa
Signal filtering:	<b>switchable 1 s / 10 s</b> (via DIP switches)
Output:	0 -10 V 1 changeover contact (24 V), 1 A ohmic load
Connection type:	3-wire connection
Electrical connection:	0.14 -1.5 mm <sup>2</sup> , via plug-in screw terminal
Cable connection:	<b>cable gland, stainless steel V2A</b> (1.4305) (M20 x 1.5; with strain relief, exchangeable, inner diameter 6 - 12 mm) or <b>M12 connector</b> (male, <b>12-pin</b> , A-code) according to DIN EN 61076-2-101
Housing:	<b>stainless steel V4A</b> (1.4571), with non-distortion cover bolting, impact-resistant, high EMI shielding, corrosion, temperature, weather- and UV-resistant
Housing dimensions:	143 x 97 x 61 mm (Tyr2E)
Air humidity:	< 95 % r. H., non-precipitating air
Protection class:	III (according to EN 60 730)
Protection type:	<b>IP 65</b> (according to EN 60 529) in the built-in state Housing tested, TÜV SÜD, Report No. 713160960B (Skadi2)
Standards:	CE conformity according to EMC Directive 2014 / 30 / EU, according to EN 61326-1, according to EN 61326-2-3
Equipment:	<b>display with illumination</b> , three-line, cutout approx. 70 x 40 mm (W x H), for displaying ACTUAL pressure and/or SETPOINT pressure as well as automatic zero point calibration
<b>ACCESSORIES</b>	(see table)

**Pressure port**  
Stainless steel  
quick connect  
(standard)



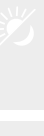

Dimensional drawing **PREMASREG® 711x-VA**

Housing with **cable gland**  
equipped as standard with **quick connect** for pressure hoses

Housing with **M12 connector**  
equipped as standard with **quick connect** for pressure hoses

**Stainless steel quick connect**

**M12 connector (male)**



**PREMASREG® 711x-VA**  
with cable gland  
and display



**PREMASREG® 711x-VAQ**  
with M12 connector  
and display

Dimensional drawing **PREMASREG® 711x-VA**

Housing with **cable gland**  
**optional** on request with **pipe fitting** for pressure lines

Housing with **M12 connector**  
**optional** on request with **pipe fitting** for pressure lines

**Stainless steel V2A pipe fitting**

**M12 connector (male)**



**Pressure port**  
Stainless steel V2A  
pipe fitting  
(optional)



Pressure and differential pressure measuring transducers/switches,  
with multi-range switching  
and adjustable, switching and active output

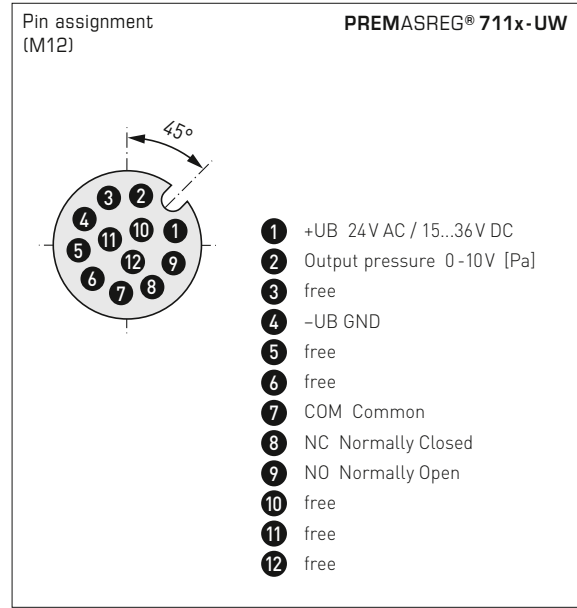
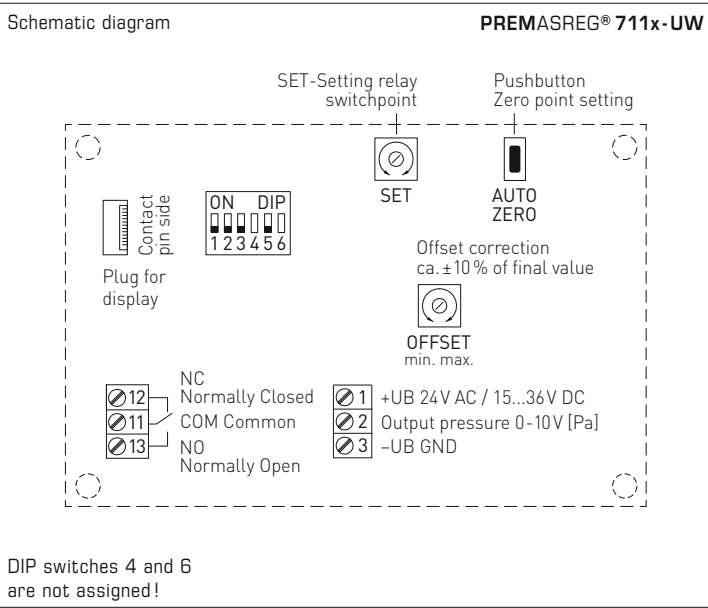

Pressure range (selectable) – max. measuring range (default) is depending to the type of device				DIP 1	DIP 2
0...100 Pa	0...1000 Pa	-100...+100 Pa	-1000...+1000 Pa	OFF	OFF
0...300 Pa	0...2000 Pa	-300...+300 Pa	-2000...+2000 Pa	ON	OFF
0...500 Pa	0...3000 Pa	-500...+500 Pa	-3000...+3000 Pa	OFF	ON
0...1000 Pa	0...5000 Pa	-1000...+1000 Pa	-5000...+5000 Pa	ON	ON

Measuring range mode (Mode selectable)	DIP 3
Unidirectional (0...+MR) (default)	OFF
Bidirectional (-MR...+MR)	ON

Measurement signal filtering (Time interval selectable)	DIP 5
10 s (default)	OFF
1 s	ON

Display with option automatic zero point calibration



**Zero point calibration active**

Remaining calibration time (in seconds)

Cycle time (approx. 90 minutes) is fixed in the factory.



PREMASREG® 711x-VAQ  
with display,  
hinged

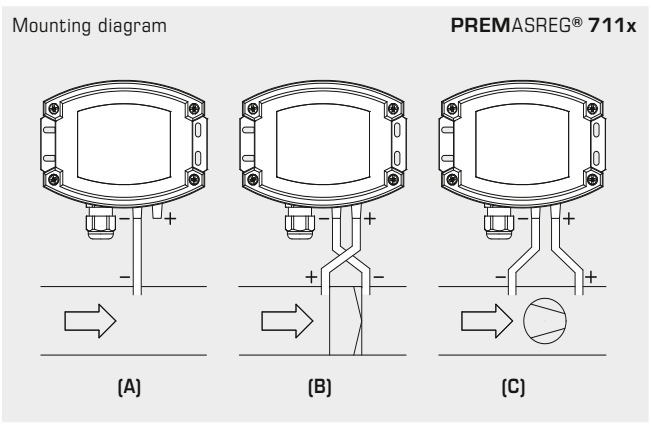

**TYPES OF MONITORING:**

- (A) Below-atmospheric pressure:**  
P1 (+) is not connected  
but open against atmosphere  
P2 (-) connected to inside of duct
- (B) Filter:**  
P1 (+) connected upstream of filter  
P2 (-) connected downstream of filter
- (C) Ventilator:**  
P1 (+) connected downstream of ventilator  
P2 (-) connected upstream of ventilator

Pressure connections at the pressure switch are marked with P1 (+) for higher pressure and P2 (-) for lower pressure.

**Conversion table for pressure values:**

Unit =	bar	mbar	Pa	kPa	mWS
1 Pa	0,00001 bar	0,01 mbar	1 Pa	0,001 kPa	0,000101971 mWS
1 kPa	0,01 bar	10 mbar	1000 Pa	1 kPa	0,101971 mWS
1 bar	1 bar	1000 mbar	100000 Pa	100 kPa	10,1971 mWS
1 mbar	0,001 bar	1 mbar	100 Pa	0,1 kPa	0,0101971 mWS
1 mWS	0,0980665 bar	98,0665 mbar	9806,65 Pa	9,80665 kPa	1 mWS

Pressure and differential pressure measuring transducers/switches,  
with multi-range switching  
and adjustable, switching and active output

PREMASREG® 711x-VAQ  
with M12 connector



PREMASREG® 711x-VAQ		Pressure and differential pressure measuring transducers/switches, <i>ID</i> (Stainless steel housing with M12 connector)			
Pressure range (adjustable)	Type / WG02I	Output	Display ● = Q	Item No.	Price
<b>max. - 1000...+ 1000 Pa</b>		<b>Type 7111</b>			
0... 100 Pa / - 100... + 100 Pa	PREMASREG 7111-UW VAQ LCD	0-10V 1x Changeover contact	● ■	2004-6192-4100-001	<b>711,86 €</b>
0... 300 Pa / - 300... + 300 Pa					
0... 500 Pa / - 500... + 500 Pa					
0... 1000 Pa / -1000... + 1000 Pa					
<b>max. - 5000...+ 5000 Pa</b>		<b>Type 7115</b>			
0... 1000 Pa / - 1000 ... + 1000 Pa	PREMASREG 7115-UW VAQ LCD	0-10V 1x Changeover contact	● ■	2004-6192-4100-011	<b>711,86 €</b>
0... 2000 Pa / -2000 ... + 2000 Pa					
0... 3000 Pa / -3000 ... + 3000 Pa					
0... 5000 Pa / -5000 ... + 5000 Pa					
<b>Housing variant "Q":</b>		Cable connection with <b>M12 connector</b> (male, <b>12-pin</b> , A-code)			
<b>Multi-range switching:</b>		The <b>pressure ranges</b> depend on the device type and can be set via DIP switches.			
<b>Extra charge:</b>		Other special measuring ranges up to max. 5000 Pa <b>with optional automatic zero point calibration</b> <b>with optional pipe fitting</b> made from stainless steel V2A for pressure lines Ø <b>6 mm</b>			<b>47,46 €</b> <b>69,10 €</b> <b>39,94 €</b>

ACCESSORIES	
<b>xx-M12</b>	<b>Special accessories for M12 connector</b>
For further information, see chapter Accessories!	





Pressure and differential pressure measuring transducers/switches,  
with multi-range switching  
and adjustable, switching and active output

PREMASREG® 711x-VA  
with cable gland



PREMASREG® 711x-VA		Pressure and differential pressure measuring transducers/switches, ID (Stainless steel housing with cable gland)			
Pressure range (adjustable)	Type/WG02I	Output	Display	Item No.	Price
<b>max. - 1000...+ 1000 Pa</b>		<b>Type 7111</b>			
0... 100 Pa / - 100... + 100 Pa	PREMASREG 7111-UW VA LCD	0-10V 1x Changeover contact	■	2004-6192-4200-001	<b>675,17 €</b>
0... 300 Pa / - 300... + 300 Pa					
0... 500 Pa / - 500... + 500 Pa					
0... 1000 Pa / -1000... + 1000 Pa					
<b>max. - 5000...+ 5000 Pa</b>		<b>Type 7115</b>			
0...1000 Pa / - 1000 ... + 1000 Pa	PREMASREG 7115-UW VA LCD	0-10V 1x Changeover contact	■	2004-6192-4200-011	<b>675,17 €</b>
0...2000 Pa / -2000 ... + 2000 Pa					
0...3000 Pa / -3000 ... + 3000 Pa					
0...5000 Pa / -5000 ... + 5000 Pa					
<b>Housing variant:</b>	Cable connection with <b>cable gland</b> made from stainless steel V2A (1.4305)				
<b>Multi-range switching:</b>	The <b>pressure ranges</b> depend on the device type and can be set via DIP switches.				
<b>Extra charge:</b>	Other special measuring ranges up to max. 5000 Pa <b>with optional automatic zero point calibration</b> <b>with optional pipe fitting</b> made from stainless steel V2A for pressure lines Ø 6 mm				<b>47,46 €</b> <b>69,10 €</b> <b>39,94 €</b>

**Pressure port**

equipped as standard with  
**quick connect**  
for pressure hoses



optional on request  
with **pipe fitting**  
for pressure lines

**Pressure measuring transducers / switches / monitors for volume flow, differential pressure, filter monitoring and liquid level detection, incl. connection set**

The electronic **PREMASREG® 716x** pressure sensor and switch is equipped with measuring functions for volume flow, differential pressure, filter monitoring and liquid level detection based on pressure measurement in clean air. The devices with a housing made from impact-resistant plastic, with **cable gland** or **M12 connector** according to DIN EN 61076-2-101 and with metal pressure port nozzles (quick connect optional) are fitted with one switching output, one continuous output and one backlit display for setting the switching point and displaying the ACTUAL values. The piezoresistive measuring element guarantees a high degree of reliability and accuracy.

This pressure sensor is used in clean room, medical and filter technology, in ventilation and air conditioning ducts, in spray booths, in large-scale catering facilities, for filter monitoring and level measurement or for triggering frequency converters. The medium measured is air (non-precipitating), or other gaseous, non-aggressive, non-combustible media.

It has a manual zero point pushbutton and an offset potentiometer for final value correction. Parameter entry is menu-based and is easy to perform using three buttons with the help of the display. The sensor is factory-calibrated; an environmental precision adjustment by an expert is possible. A connection set **ASD-06** (2 m connection hose, two pressure nipples, screws) is included in the scope of supply.

#### TECHNICAL DATA

Power supply:	24 V AC / DC (± 10 %) and 15...36 V DC
Load resistance:	$R_L > 5 \text{ k}\Omega$
Power consumption:	< 1.5 VA / 24 V DC, < 2.8 VA / 24 V AC
Measuring function:	<b>Volume flow, differential pressure, filter monitoring, fill level</b> (adjustable)
Measuring ranges:	<b>10...100%</b> (adjustable)
Type of pressure:	differential pressure
Pressure connection:	equipped as standard with metal connection <b>nozzles</b> for pressure hose $\varnothing 6 \text{ mm}$ , optionally with <b>quick connect</b> made from stainless steel for PVC fabric pressure hose $\varnothing 6 \text{ mm}$ (external diameter)
Medium:	clean air and non-aggressive, non-combustible gases
Media temperature:	-20...+50 °C
Accuracy:	<b>Type 7161</b> (1000 Pa): typically $\pm 5 \text{ Pa}$ <b>Type 7165</b> (5000 Pa): typically $\pm 25 \text{ Pa}$ compared to the calibrated reference device
Sum of linearity+hysteresis:	< $\pm 1 \%$ of final value (pressure)
Temp. drift values:	$\pm 0.1 \%$ / °C
Positive / negative pressure:	max. $\pm 10000 \text{ Pa}$
Signal hysteresis:	$\pm 1 \%$ of final value (pressure) 10 Pa / 50 Pa
Signal filtering:	<b>switchable 1 s / 10 s</b> (via DIP switches) and small value suppression < 1 %
Output:	0-10 V 1 changeover contact (24 V), 1 A ohmic load
Connection type:	3-wire connection
Electrical connection:	0.14-1.5 mm <sup>2</sup> , via plug-in screw terminal
Cable connection:	<b>cable gland</b> , plastic (M 16 x 1.5; with strain relief, exchangeable, max. inner diameter 10.4 mm) <b>or</b> <b>M12 connector</b> (male, <b>12-pin</b> , A-code) according to DIN EN 61076-2-101
Housing:	<b>plastic</b> , UV-resistant, material polyamide, 30 % glass-globe reinforced, with quick-locking screws (slotted / Phillips head combination), colour traffic white (similar to RAL 9016), cover for display is transparent!
Housing dimensions:	126 x 90 x 50 mm (Tyr 2)
Air humidity:	< 95 % r. H., non-precipitating air
Protection class:	III (according to EN 60 730)
Protection type:	<b>IP 65</b> (according to EN 60 529) in the built-in state
Standards:	CE conformity according to EMC Directive 2014 / 30 / EU, according to EN 61326-1, according to EN 61326-2-3
Equipment:	<b>display with illumination</b> , three-line, cutout approx. 70 x 40 mm (W x H), for displaying the <b>volume flow, differential pressure, contamination degree</b> or <b>level</b> and for setting the <b>switchpoint, K factor, measuring range limits</b> and other settings
K factor:	<b>1 to 3000</b> (adjustable)
Units:	m <sup>3</sup> /s, m <sup>3</sup> /min, m <sup>3</sup> /h, l/s, l/min, l/h, %, cm (adjustable)
Max. value displayed:	999999
<b>ACCESSORIES</b>	see table

**Pressure port**  
Metal nozzles  
(standard)





Dimensional drawing

PREMASREG® 716x

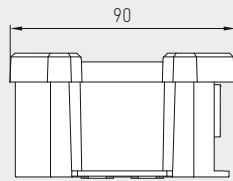
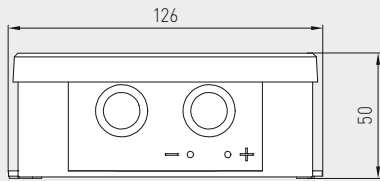

Housing with cable gland

equipped as standard with pressure port nozzles

Housing with M12 connector

equipped as standard with pressure port nozzles

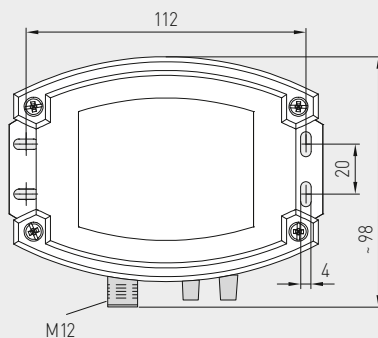
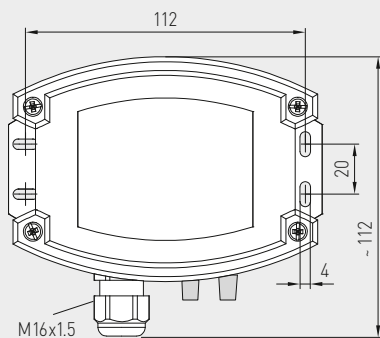

Pressure port nozzles, metal



M12 connector (male)

PREMASREG® 716x with cable gland and display



PREMASREG® 716x-Q with M12 connector and display



Pressure port Stainless steel quick connect (optional)

Dimensional drawing

PREMASREG® 716x

Housing with cable gland

optional on request with quick connect

Housing with M12 connector

optional on request with quick connect

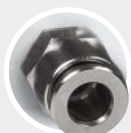
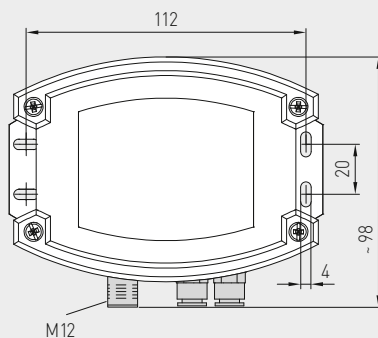
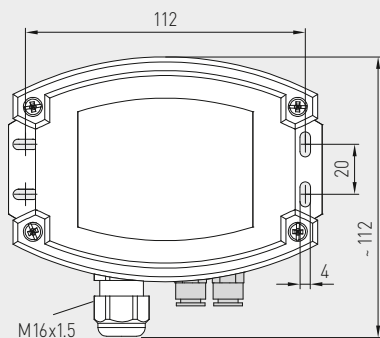

Stainless steel quick connect



M12 connector (male)



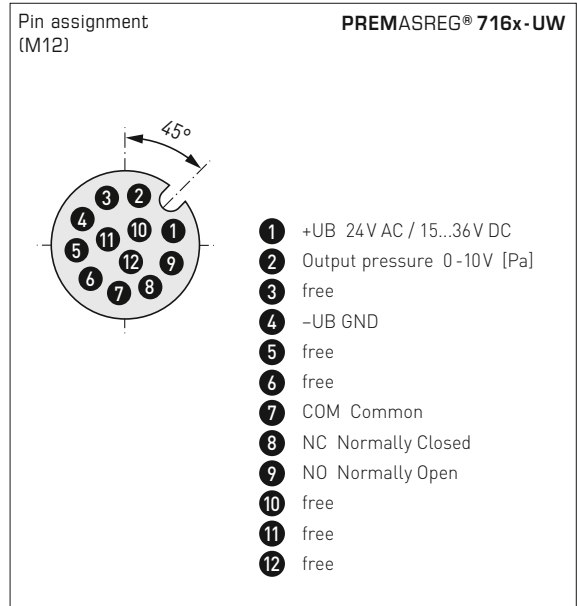
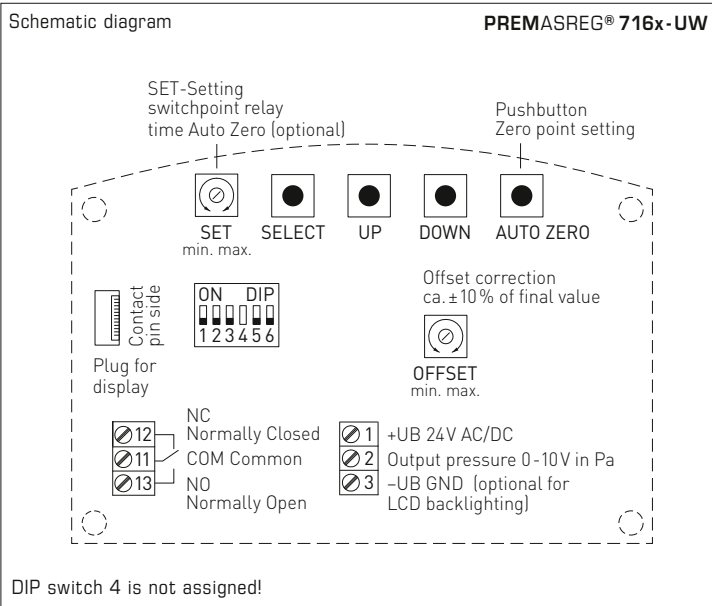

Measuring range mode (Mode selectable)	DIP 1
Unidirectional (0...+MR) (default)	OFF
Bidirectional (-MR...+MR)	ON

Small value suppression (measured values < 1% of end value (pressure) = 0)	DIP 2
Deactivated (default)	OFF
Active	ON

Relay (Function adjustable)	DIP 3
Deactivated (default)	OFF
Active (display shows switching point)	ON

Measurement signal filtering (Time interval selectable)	DIP 5
10s (default)	OFF
1s	ON

Service mode (display adjustable)	DIP 6
Standard (according to configuration) (default)	OFF
Service (differential pressure in Pa)	ON

**PREMASREG® 716x**  
Function types



**Volumetric flow rate**

$$V = k \cdot \sqrt{\Delta p}$$

V = Volume flow in m³/h  
k = K factor 1...3000  
Δp = Differential pressure in Pa



**Differential pressure**

$$\Delta p = p_+ - p_-$$

Δp = Differential pressure in Pa  
p<sub>+</sub> = higher pressure  
p<sub>-</sub> = lower pressure



**Filter contamination**

$$S = 100\% \cdot \Delta p \div p_{Filter}$$

S = Contamination degree in %  
Δp = Differential pressure in Pa  
p<sub>Filter</sub> = differential pressure filter replacement in Pa



**Level display**

$$h = \Delta p \div (\rho \cdot g)$$

h = Fill level height in cm  
Δp = Differential pressure in Pa  
ρ = Density 700...1300 in kg/m³  
g = 9.81 m/s²



PREMASREG® 716x-Q  
with display,  
hinged

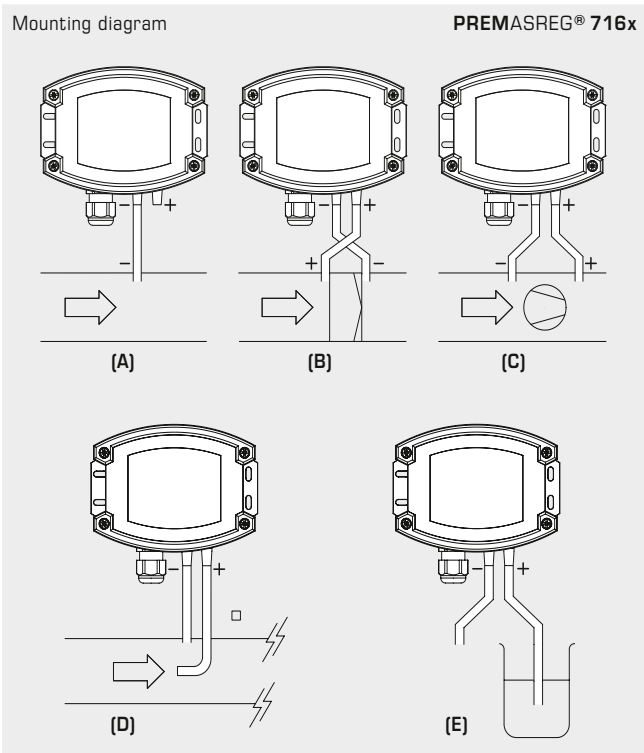

**TYPES OF MONITORING:**

- (A) **Below-atmospheric pressure:**  
P1 (+) is not connected, but open to the atmosphere  
P2 (-) connected to inside of duct
  - (B) **Filter:**  
P1 (+) connected upstream of filter  
P2 (-) connected downstream of filter
  - (C) **Ventilator:**  
P1 (+) connected downstream of ventilator  
P2 (-) connected upstream of ventilator
  - (D) **Volume flow:**  
P1 (+) dynamic pressure, Connected in flow direction  
P2 (-) static pressure, Connected free of dynamic pressure components
  - (E) **Level:**  
P1 (+) Connection submerged in medium  
P2 (-) Connection is open to the atmosphere
- Pressure connections at the pressure switch are marked with P1 (+) for higher pressure and P2 (-) for lower pressure.

**Conversion table for pressure values:**

Unit =	bar	mbar	Pa	kPa	mWS
1 Pa	0,00001 bar	0,01 mbar	1 Pa	0,001 kPa	0,000101971 mWS
1 kPa	0,01 bar	10 mbar	1000 Pa	1 kPa	0,101971 mWS
1 bar	1 bar	1000 mbar	100000 Pa	100 kPa	10,1971 mWS
1 mbar	0,001 bar	1 mbar	100 Pa	0,1 kPa	0,0101971 mWS
1 mWS	0,0980665 bar	98,0665 mbar	9806,65 Pa	9,80665 kPa	1 mWS



Pressure measuring transducers / switches / monitors for volume flow, differential pressure, filter monitoring and liquid level detection, incl. connection set

Dimensional drawing **ASD-06**  
Connection set

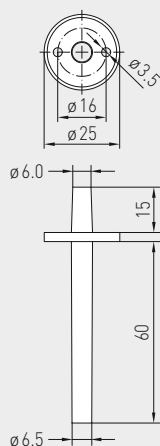

**ASD-06**  
Connection set



Dimensional drawing **ASD-07**  
Connection nipple

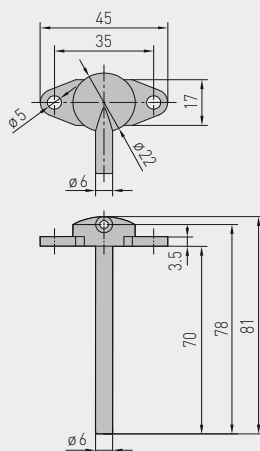

**ASD-07**  
Connection nipple



**WS-03**  
Weather and sun protection hood (optional)

**Pressure port**  
equipped as standard with pressure port metal nozzles



optional on request with stainless steel quick connect



**ACCESSORIES**

<b>ASD-06</b>	<b>Connection set (included in the scope of delivery)</b> , consisting of 2 connection nipples (straight) made of ABS, 2 m PVC hose (soft, UV-resistant) and 4 screws	7100-0060-3000-000	<b>7,28 €</b>
<b>ASD-07</b>	<b>2 connection nipples</b> (at 90 degree angle) made of plastic, ABS	7100-0060-7000-000	<b>7,28 €</b>
<b>WS-03</b>	<b>Weather and sun protection hood</b> , 200 x 180 x 150 mm, stainless steel V2A (1.4301)	7100-0040-6000-000	<b>42,61 €</b>

For further information, see chapter Accessories!



PREMASREG® 716x-Q  
with M12 connector



PREMASREG® 716x  
with cable gland



Measuring Range Pressure / Volume Flow		Type / WG02	Output	Display ● = Q	Item No.	Price
<b>0...1000 Pa</b>		<b>Type 7161</b>				
k = 3000      94800 m³/h	PREMASREG 7161-UW	LCD	0-10V 1x Changeover contact	■	1302-7161-4161-200	264,90 €
	PREMASREG 7161-UW Q	LCD	0-10V 1x Changeover contact	● ■	2004-6132-4100-021	304,82 €
<b>0...5000 Pa</b>		<b>Type 7165</b>				
k = 3000      212100 m³/h	PREMASREG 7165-UW	LCD	0-10V 1x Changeover contact	■	1302-7161-4171-200	264,90 €
	PREMASREG 7165-UW Q	LCD	0-10V 1x Changeover contact	● ■	2004-6132-4100-031	304,82 €
<b>Housing variant "Q":</b>		Cable connection with <b>M12 connector</b> (male, <b>12-pin</b> , A-code)				
<b>Multi-range switching:</b>		The <b>pressure ranges</b> depend on the device type and can be set via DIP switches.				
<b>Extra charge:</b>		<b>with optional quick connect</b> for PVC fabric pressure hose Ø 6 mm				<b>39,94 €</b>

**Pressure measuring transducers / switches / monitors for volume flow,  
differential pressure, filter monitoring and liquid level detection**

The electronic **PREMASREG® 761x-VA** pressure sensor and switch is equipped with measuring functions for volume flow, differential pressure, filter monitoring and liquid level detection based on pressure measurement in clean air. The devices with a housing made from **stainless steel V4A**, with **cable gland** or **M12 connector** according to DIN EN 61076-2-101 and pressure port by stainless steel quick connect (pipe fitting optional) are fitted with one switching output, one continuous output and a backlit display for setting the switching point and displaying the ACTUAL values. The piezoresistive measuring element guarantees a high degree of reliability and accuracy.

This pressure sensor is used in clean room, medical and filter technology, in ventilation and air conditioning ducts, in spray booths, in large-scale catering facilities, for filter monitoring and level measurement or for triggering frequency converters. The medium measured is air (non-precipitating), or other gaseous, non-aggressive, non-combustible media.

It has a manual zero point pushbutton and an offset potentiometer for final value correction. Parameter entry is menu-based and is easy to perform using three buttons with the help of the display. The sensor is factory-calibrated; an environmental precision adjustment by an expert is possible.

**TECHNICAL DATA**

Power supply:	24 V AC / DC ( $\pm 10\%$ ) and 15...36 V DC
Load resistance:	$R_L > 5 \text{ k}\Omega$
Power consumption:	$< 1.5 \text{ VA} / 24 \text{ V DC}$ , $< 2.8 \text{ VA} / 24 \text{ V AC}$
Measuring function:	<b>Volume flow, differential pressure, filter monitoring, fill level</b> (adjustable)
Measuring ranges:	<b>10...100%</b> (adjustable)
Type of pressure:	differential pressure
Pressure port:	equipped as standard with <b>quick connect</b> made from stainless steel for PVC-fabric pressure hose $\varnothing 6 \text{ mm}$ (external diameter) optionally with <b>pipe fitting</b> , stainless steel V2A (1.4305) for pressure lines $\varnothing 6 \text{ mm}$
Medium:	clean air and non-aggressive, non-combustible gases
Media temperature:	$-20...+50 \text{ }^\circ\text{C}$
Accuracy:	<b>Type 7161</b> (1000 Pa): typically $\pm 5 \text{ Pa}$ <b>Type 7165</b> (5000 Pa): typically $\pm 25 \text{ Pa}$ compared to the calibrated reference device
Sum of linearity+hysteresis:	$< \pm 1\%$ of final value (pressure)
Temp. drift values:	$\pm 0.1\% / ^\circ\text{C}$
Positive / negative pressure:	max. $\pm 10000 \text{ Pa}$
Signal hysteresis:	$\pm 1\%$ of final value (pressure) 10 Pa / 50 Pa
Signal filtering:	<b>switchable 1 s / 10 s</b> (via DIP switches) and small value suppression $< 1\%$
Output:	0-10 V 1 changeover contact (24V), 1 A ohmic load
Connection type:	3-wire connection
Electrical connection:	0.14-1.5 mm <sup>2</sup> , via plug-in screw terminal
Cable connection:	<b>cable gland, stainless steel V2A</b> (1.4305) (M20 x 1.5; with strain relief, exchangeable, inner diameter 6-12 mm) or <b>M12 connector</b> (male, 12-pin, A-code) according to DIN EN 61076-2-101
Housing:	<b>stainless steel V4A</b> (1.4571), with non-distortion cover bolting, impact-resistant, high EMI shielding, corrosion, temperature, weather- and UV-resistant
Housing dimensions:	143 x 97 x 61 mm (Tyr2E)
Air humidity:	$< 95\%$ r. H., non-precipitating air
Protection class:	III (according to EN 60730)
Protection type:	<b>IP 65</b> (according to EN 60529) in the built-in state Housing tested, TÜV SÜD, Report No. 713160960B (Skadi2)
Standards:	CE conformity according to EMC Directive 2014/30/EU, according to EN 61326-1, according to EN 61326-2-3
Equipment:	<b>display with illumination</b> , three-line, cutout approx. 70 x 40 mm (W x H), for displaying the <b>volume flow, differential pressure, contamination degree or level</b> and for setting the <b>switchpoint, K factor, measuring range limits</b> and other settings
K factor:	<b>1 to 3000</b> (adjustable)
Units:	<b>m<sup>3</sup>/s, m<sup>3</sup>/min, m<sup>3</sup>/h, l/s, l/min, l/h, %, cm</b> (adjustable)
Max. value displayed:	999999
<b>ACCESSORIES</b>	(see table)

**Pressure port**  
Stainless steel  
quick connect  
(standard)





Dimensional drawing

PREMASREG® 716x-VA

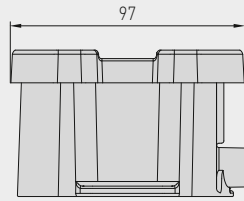
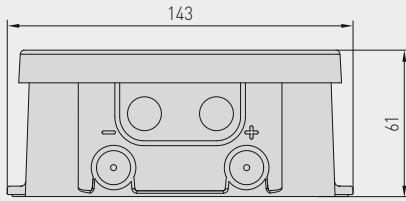

Housing with cable gland equipped as standard with quick connect for pressure hoses

Housing with M12 connector equipped as standard with quick connect for pressure hoses

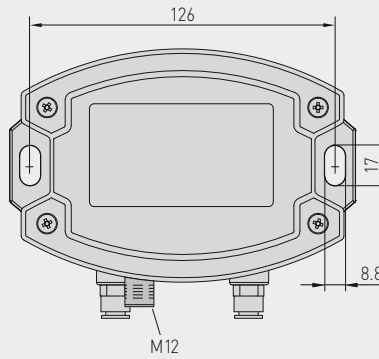
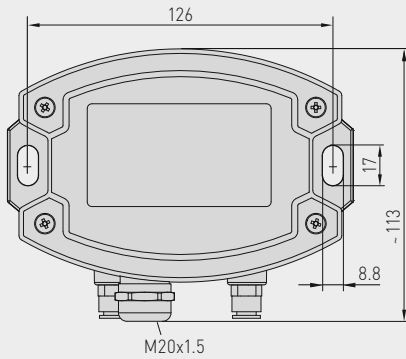

Stainless steel quick connect



M12 connector (male)

PREMASREG® 716x-VA with cable gland and display



PREMASREG® 716x-VAQ with M12 connector and display



Dimensional drawing

PREMASREG® 716x-VA

Housing with cable gland optional on request with pipe fitting for pressure lines

Housing with M12 connector optional on request with pipe fitting for pressure lines

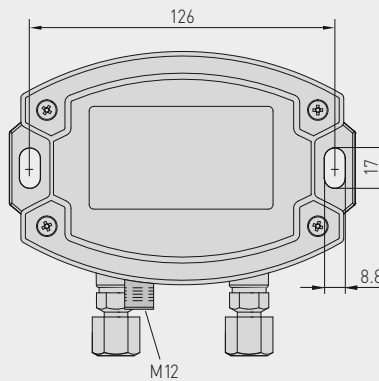
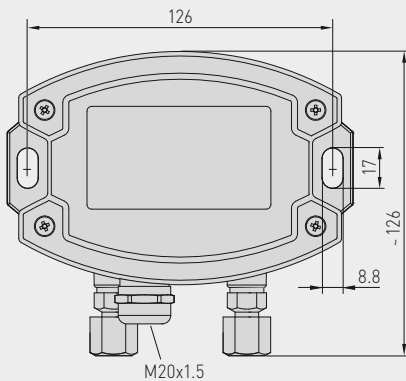

Stainless steel V2A pipe fitting



M12 connector (male)



Pressure port Stainless steel V2A pipe fitting (optional)



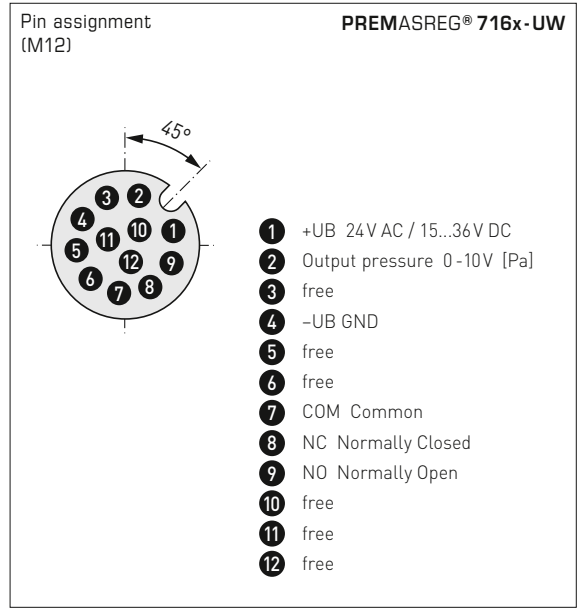
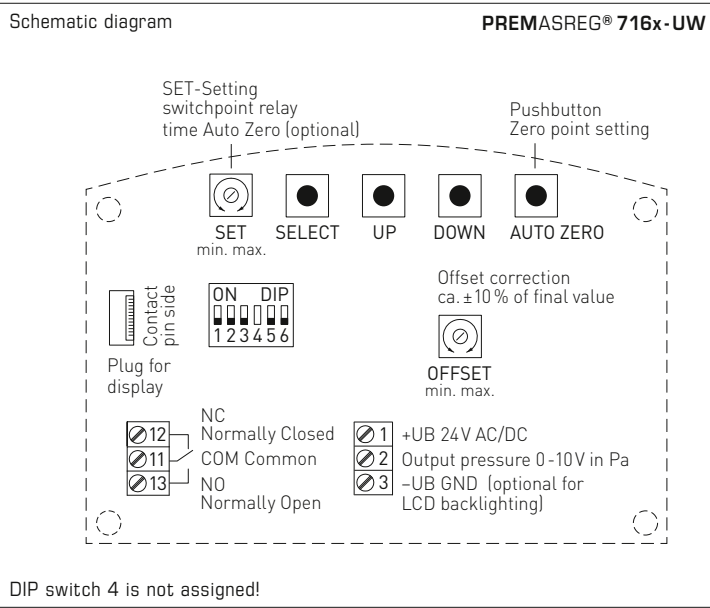

Measuring range mode (Mode selectable)	DIP 1
Unidirectional (0...+MR) (default)	OFF
Bidirectional (-MR...+MR)	ON

Small value suppression (measured values < 1% of end value (pressure) = 0)	DIP 2
Deactivated (default)	OFF
Active	ON

Relay (Function adjustable)	DIP 3
Deactivated (default)	OFF
Active (display shows switching point)	ON

Measurement signal filtering (Time interval selectable)	DIP 5
10 s (default)	OFF
1 s	ON

Service mode (display adjustable)	DIP 6
Standard (according to configuration) (default)	OFF
Service (differential pressure in Pa)	ON

**PREMASREG® 716x**  
Function types

**Volumolum flow rate**

$$V = k \cdot \sqrt{\Delta p}$$

V = Volume flow in m³/h  
k = K factor 1...3000  
Δp = Differential pressure in Pa

**Differential pressure**

$$\Delta p = p_+ - p_-$$

Δp = Differential pressure in Pa  
p<sub>+</sub> = higher pressure  
p<sub>-</sub> = lower pressure

**Filter contamination**

$$S = 100\% \cdot \Delta p \div p_{Filter}$$

S = Contamination degree in %  
Δp = Differential pressure in Pa  
p<sub>Filter</sub> = differential pressure filter replacement in Pa

**Level display**

$$h = \Delta p \div (\rho \cdot g)$$

h = Fill level height in cm  
Δp = Differential pressure in Pa  
ρ = Density 700...1300 in kg/m³  
g = 9.81 m/s²



PREMASREG® 716x-VAQ  
with display,  
hinged

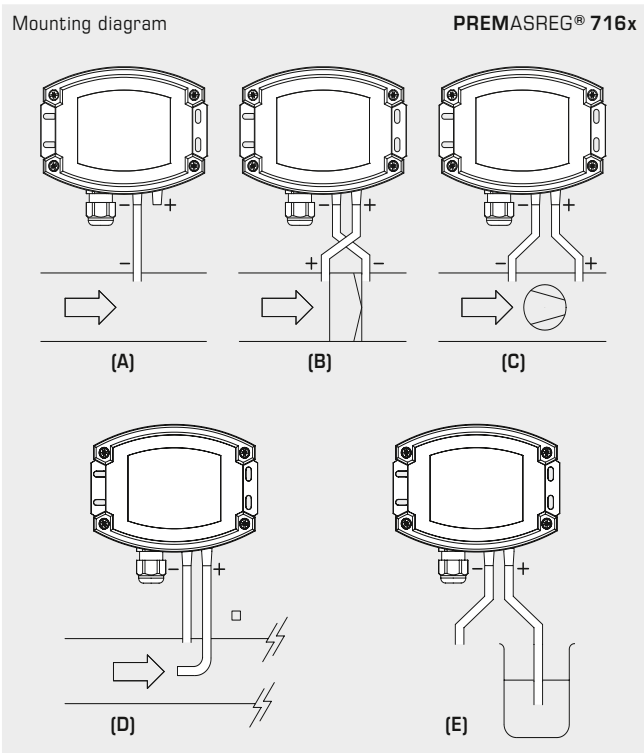

**TYPES OF MONITORING:**

- (A) **Below-atmospheric pressure:**  
P1 (+) is not connected, but open to the atmosphere  
P2 (-) connected to inside of duct
  - (B) **Filter:**  
P1 (+) connected upstream of filter  
P2 (-) connected downstream of filter
  - (C) **Ventilator:**  
P1 (+) connected downstream of ventilator  
P2 (-) connected upstream of ventilator
  - (D) **Volume flow:**  
P1 (+) dynamic pressure, Connected in flow direction  
P2 (-) static pressure, Connected free of dynamic pressure components
  - (E) **Level:**  
P1 (+) Connection submerged in medium  
P2 (-) Connection is open to the atmosphere
- Pressure connections at the pressure switch are marked with P1 (+) for higher pressure and P2 (-) for lower pressure.

**Conversion table for pressure values:**

Unit =	bar	mbar	Pa	kPa	mWS
1 Pa	0,00001 bar	0,01 mbar	1 Pa	0,001 kPa	0,000101971 mWS
1 kPa	0,01 bar	10 mbar	1000 Pa	1 kPa	0,101971 mWS
1 bar	1 bar	1000 mbar	100000 Pa	100 kPa	10,1971 mWS
1 mbar	0,001 bar	1 mbar	100 Pa	0,1 kPa	0,0101971 mWS
1 mWS	0,0980665 bar	98,0665 mbar	9806,65 Pa	9,80665 kPa	1 mWS

PREMASREG® 716x-VAQ  
with M12 connector



PREMASREG® 716x-VAQ		Pressure measuring transducers / switches / monitors for volume flow, differential pressure, filter monitoring and liquid level detection, ID					
Stainless steel housing with M12 connector							
Measuring Range	Type / WG02I	Output	Display	Item No.	Price		
Pressure / Volume Flow			● = Q				
<b>0...1000 Pa</b>		<b>Type 7161</b>					
k = 3000	94800 m³/h	PREMASREG 7161-UW VAQ LCD	0-10V 1x Changeover contact	● ■ 2004-6192-4100-021	765,43 €		
<b>0...5000 Pa</b>		<b>Type 7165</b>					
k = 3000	212100 m³/h	PREMASREG 7165-UW VAQ LCD	0-10V 1x Changeover contact	● ■ 2004-6192-4100-031	765,43 €		
<b>Housing variant "Q":</b>		Cable connection with <b>M12 connector</b> (male, <b>12-pin</b> , A-code)					
Multi-range switching:		The <b>pressure ranges</b> depend on the device type and can be set via DIP switches.					
Extra charge:		with <b>optional pipe fitting</b> made from stainless steel V2A for pressure lines Ø <b>6 mm</b>				39,94 €	

ACCESSORIES	
xx-M12	Special accessories for M12 connector
For further information, see chapter Accessories!	



PREMASREG® 716x-VA  
with cable gland



PREMASREG® 716x-VA		Pressure measuring transducers / switches / monitors for volume flow, differential pressure, filter monitoring and liquid level detection, <i>ID</i> Stainless steel housing with cable gland			
Measuring Range Pressure / Volume Flow	Type / WG02I	Output	Display	Item No.	Price
<b>0...1000 Pa</b>		<b>Type 7161</b>			
k = 3000      94800 m³/h	PREMASREG 7161-UW VA LCD	0-10V 1x Changeover contact	■	2004-6192-4200-021	<b>728,72 €</b>
<b>0...5000 Pa</b>		<b>Type 7165</b>			
k = 3000      212100 m³/h	PREMASREG 7165-UW VA LCD	0-10V 1x Changeover contact	■	2004-6192-4200-031	<b>728,72 €</b>
<b>Housing variant:</b>	Cable connection with <b>cable gland</b> made from stainless steel V2A (1.4305)				
<b>Multi-range switching:</b>	The <b>pressure ranges</b> depend on the device type and can be set via DIP switches.				
<b>Extra charge:</b>	<b>with optional pipe fitting</b> made from stainless steel V2A for pressure lines Ø 6 mm				<b>39,94 €</b>



**Pressure port**  
equipped as standard with **quick connect** for pressure hoses



optional on request with **pipe fitting** for pressure lines



## Barometers /

**Measuring transducers for atmospheric pressure,  
calibratable, with active output**

S+S REGELTECHNIK

ALD

Calibratable barometer **PREMASGARD® ALD** with active output (U/I switchable) and 4 measuring ranges (max. 600...1100 hPa, switchable), in a compact plastic housing with quick-locking screws, optionally with/without display.

The pressure sensor is used for measuring atmospheric air pressure in clean air (non-precipitating) or other non-aggressive, non-combustible gases. It is used in various applications such as ventilation and air conditioning technology, in meteorological measurement stations and air-pressure-dependent control systems.

The piezoresistive measuring element is temperature-compensated and guarantees a high degree of reliability and accuracy. The sensor is factory-calibrated; an environmental precision adjustment by an expert is possible.

**TECHNICAL DATA**

Power supply:	24 V AC/DC (± 10%)
Working resistance:	$R_a$ (Ohm) = 25 ... 450 Ohm for I-output
Load resistance:	$R_L > 25$ kOhm for U-output
Power consumption:	< 1 W at 24 V DC; < 2 VA at 24 V AC
Current consumption:	< 45 mA
Measuring ranges:	<b>multi-range switching with 4 switchable measuring ranges</b> (see table)
Output:	<b>switchable 0-10V / 4...20 mA</b> (via DIP switches)
Connection type:	3-wire connection
Ambient temperature:	storage -35...+85 °C; operation -30...+75 °C, non-precipitating
Type of pressure:	atmospheric air pressure/absolute pressure
Medium:	clean air and non-aggressive, non-combustible gases
Accuracy:	typically ± 0.4 kPa compared to calibrated reference device
Zero point offset:	± 50 hPa
Positive pressure:	200 kPa
Signal filtering:	<b>switchable 1 s / 10 s</b> (via DIP switches)
Temperature drift:	± 0.1 % of final value per °C
Housing:	plastic, UV-resistant, polyamide material, 30 % glass-globe reinforced, with quick-locking screws (slotted / Phillips head combination), colour traffic white (similar to RAL 9016), housing cover for display is transparent!
Housing dimensions:	72 x 64 x 37.8 mm (Tyr 1 without display) 72 x 64 x 43.3 mm (Tyr 1 with display)
Cable connection:	<b>cable gland</b> , plastic (M 16 x 1.5; with strain relief, exchangeable, inner diameter 10.4 mm) <b>or</b> <b>M12 plug-in connector</b> (flush-type connector, 5-pin, A-coding) according to DIN EN 61076-2-101 (optional, available upon request)
Electrical connection:	0.14 - 1.5mm <sup>2</sup> , via screw terminals
Air humidity:	< 95 % r. H., non-precipitating air
Protection class:	III (according to EN 60730)
Protection type:	<b>IP67</b> (according to EN 60529) housing tested, TÜV SÜD, report no. 713139052 (Tyr 1)
Standards:	CE conformity, electromagnetic compatibility according to EN 61326, EMC Directive 2014 / 30 / EU
Equipment:	<b>display</b> , one-line, cutout approx. 36 x 15 mm (W x H), for displaying the atmospheric air pressure/absolute pressure
<b>ACCESSOIRES</b>	see chapter Accessories
<b>WS-04</b>	<b>weather and sun protection hood</b> , 130 x 180 x 135 mm, stainless steel <b>V2A</b> (1.4301)

Pressure range (adjustable)	DIP 1	DIP 2
600...1100 hPa	OFF	OFF
700...1100 hPa	<b>ON</b>	OFF
800...1100 hPa	OFF	<b>ON</b>
900...1100 hPa (default)	<b>ON</b>	<b>ON</b>

Measurement signal filtering (selectable time interval)	DIP 5
10 s (default)	OFF
1 s	<b>ON</b>

Output (selectable)	DIP 6
Voltage 0-10V (default)	OFF
Current 4...20 mA	<b>ON</b>

**Conversion table for pressure values:**

Unit =	bar	mbar	Pa	kPa	mWS
<b>1 Pa</b>	0,00001 bar	0,01 mbar	1 Pa	0,001 kPa	0,000101971 mWS
<b>1 kPa</b>	0,01 bar	10 mbar	1000 Pa	1 kPa	0,101971 mWS
<b>1 bar</b>	1 bar	1000 mbar	100000 Pa	100 kPa	10,1971 mWS
<b>1 mbar</b>	0,001 bar	1 mbar	100 Pa	0,1 kPa	0,0101971 mWS
<b>1 mWS</b>	0,0980665 bar	98,0665 mbar	9806,65 Pa	9,80665 kPa	1 mWS

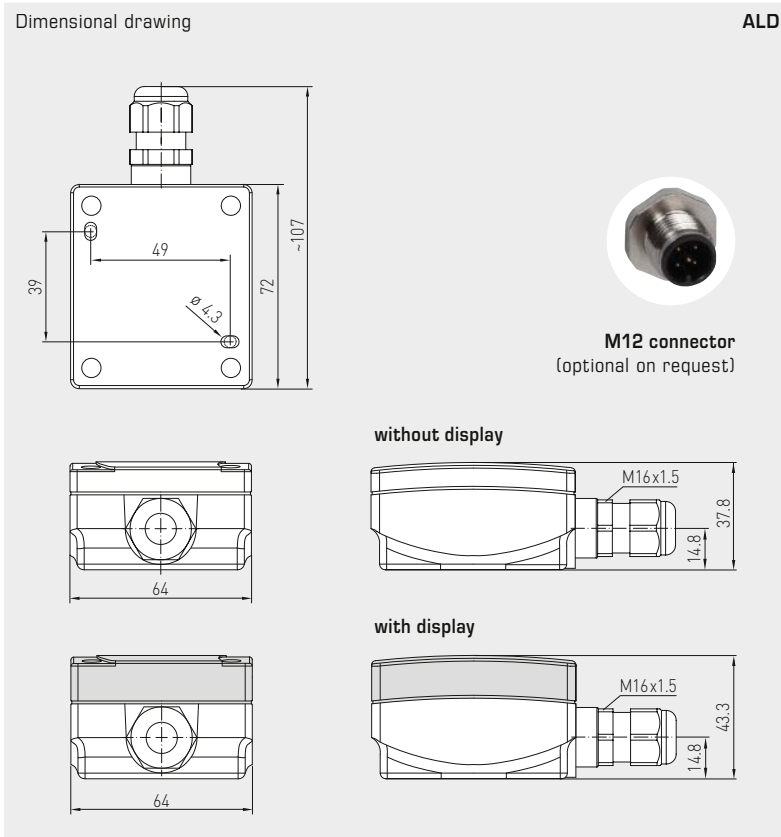

ALD  
with display

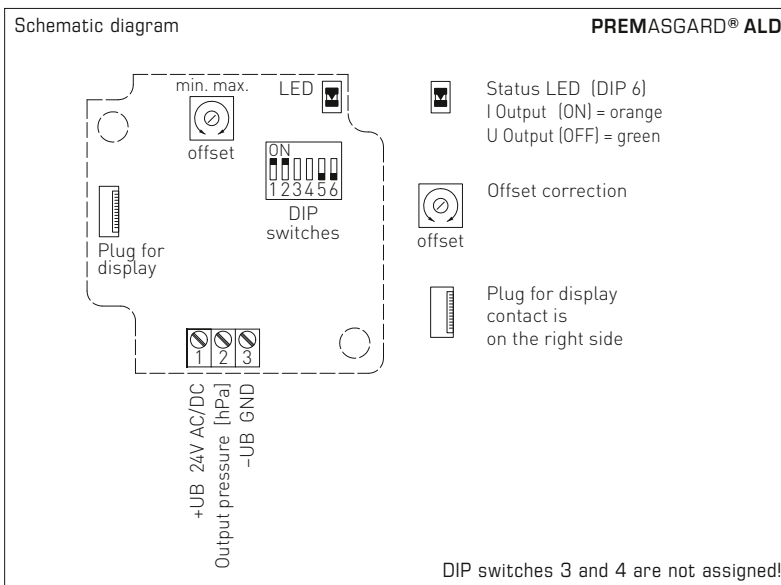

WS-04  
Weather and sun protection hood  
(optional)



PREMASGARD® ALD Measuring transducer for atmospheric pressure					
Pressure range (adjustable)	Type / WG01	Output (switchable)	Display	Item no.	Price
<b>max. 600...1100 hPa</b>	<b>ALD</b>				
600...1100 hPa	ALD	0-10V / 4...20mA		1301-1157-0130-200	<b>159,73 €</b>
700...1100 hPa					
800...1100 hPa	ALD LCD	0-10V / 4...20mA	■	1301-1157-2130-200	<b>188,37 €</b>
900...1100 hPa					
Multi-range switching:	The <b>pressure ranges</b> can be set via DIP switches.				
Output:	<b>0-10V or 4...20 mA</b> (selectable via DIP switches)				
Optional:	Cable connection with <b>M12 connector</b> according to DIN EN 61076-2-101 (on request)				



**Differential pressure switches for air,  
with mounting angle, incl. connection set**

The mechanical differential pressure switch / differential pressure monitor **PREMASREG® DS 1** with metal angle is used for monitoring above-atmospheric, differential, and below-atmospheric pressures of air and gaseous, non-aggressive media in air ducts, ventilation intake or exhaust devices, as a flow monitor, as a pressure difference detector or pressure monitor for flow detection at electric heating registers, for monitoring V-belts and filters, as air pressure deficiency protection, for monitoring fans and air dampers, or as a limit value controller. The switchpoint is adjusted using the internal precision scale.

These instruments are factory-calibrated. The differential pressure switch DS 1 is supplied including connection set **ASD-06** (2 m connection hose, two pressure connection nipples, screws) and mounting angle **DS-MW-Z**.

**DS 1**  
with mounting angle



**TECHNICAL DATA**

Switching capacity: (Contact load)	5 (0.8) A, 250 V AC 4 (0.7) A, 30 V DC
Contact:	single-pole potential-free changeover contact, multi-layer contact, gold-plated (DDC compatible)
Pressure range:	see table, high adjustment accuracy due to individual laser-etched scale for each switch
Housing:	base: material PC (10% GF), colour light grey (similar to RAL 7035), snap-on lid: material PC, transparent, cable gland PG 11 with strain relief
Temperature of medium:	-30...+85 °C
Membrane:	silicone, LSR (Liquid Silicon Rubber, tempered at +200 °C, non-outgassing, LABS-free, no emission of varnish-adhesion inhibiting substances), long-term stability of switching points due to trapezoidal bead membranes
Humidity:	< 90% r. H., non-precipitating air
Electrical connection:	0.14 - 1.5 mm <sup>2</sup> , via terminal screws with torsion protection
Pressure connection:	with connection nozzles for pressure hose Ø 6 mm
Mounting:	<b>with metal angle DS-MW-Z</b> (included in the scope of delivery) (for other optional shapes, see table) Recommended mounting position: vertical (pressure connections downward) – factory setting; horizontal (cap up / down)
Protection class:	II (according to EN 60 730)
Protection type:	<b>IP 54</b> (according to EN 60529) with top cover
Standards:	CE conformity, low-voltage directive 2014 / 35 / EU
Tests:	DVGW (according to DIN 1854), VDE 0630, EN 61058, directive on gas devices 2009 / 142 / EU, CE 0085 A P 0918

**FUNCTION**  
Contact 1 - 2 breaks when pressure / differential pressure rises to the preset value.  
Contact 1 - 3 closes when pressure / differential pressure drops and can be used as signal contact.

**ACCESSORIES**

<b>ASD-06</b>	<b>Connection set</b> (nipple straight) – (included in the scope of delivery)
<b>DS-MW-Z</b>	<b>Mounting angle</b> (included in the scope of delivery)
<b>DS-MW-L</b>	<b>Mounting angle</b> (optional)
<b>DS1-MW-U</b>	<b>Mounting angle</b> (optional), combination bracket for vertical or horizontal mounting
<b>WS-04</b>	<b>Weather and sun protection hood</b> , 130 x 180 x 135 mm, aus stainless steel <b>V2A</b> (1.4301)

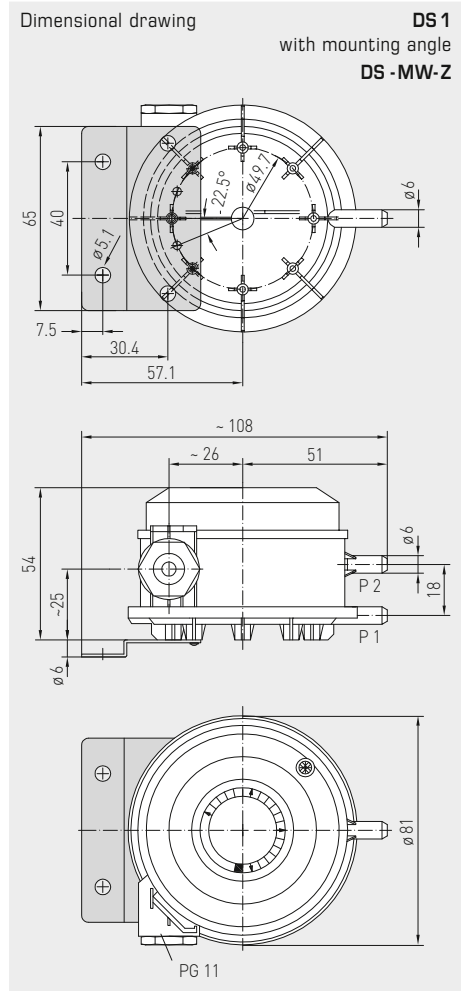
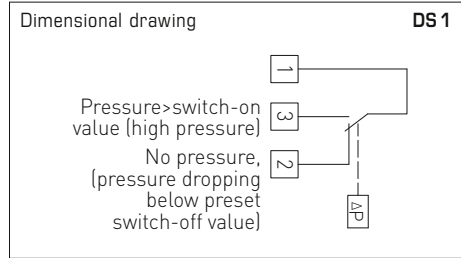



The mechanical differential pressure switch / differential pressure monitor **PREMASREG® DS-2** with 4-hole plastic base ring is used for monitoring above-atmospheric, differential and below-atmospheric pressures of clean air and other gaseous, non-aggressive non-combustible media in air ducts, air intake or exhaust devices, as a pressure difference detector or pressure monitor for flow detection at electric heating registers, for monitoring V-belts and filters, as air pressure deficiency protection, for monitoring fans and air dampers, or as a limit value controller. The switchpoint is adjusted using the internal precision scale.

These instruments are factory-calibrated. The differential pressure switch DS 2 is supplied including connection set **ASD-06** (2 m connection hose, two pressure connection nipples, screws) and mounting ring **DS-MR-K**.

**TECHNICAL DATA**

Switching capacity: (Contact load)	5 (0.8) A, 250 V AC 4 (0.7) A, 30 V DC
Contact:	single-pole potential-free changeover contact, multi-layer contact, gold-plated (DDC compatible)
Pressure range:	see table, high adjustment accuracy due to individual laser-etched scale for each switch
Housing:	base: material PC (10 % GF), colour light grey (similar to RAL 7035), snap-on lid: material PC, transparent, cable gland PG 11 with strain relief
Temperature of medium:	-30...+85 °C
Membrane:	silicone, LSR (Liquid Silicon Rubber, tempered at +200 °C, non-outgassing, LABS-free, no emission of varnish-adhesion inhibiting substances), long-term stability of switching points due to trapezoidal bead membranes
Humidity:	< 90 % r. H., non-precipitating air
Electrical connection:	0.14 - 1.5 mm <sup>2</sup> , via terminal screws with torsion protection
Pressure connection:	with connection nozzles for pressure hose Ø 6 mm
Mounting:	<b>by 4-hole base ring, plastic</b> (included in the scope of delivery), recommended mounting position: vertical (pressure connections downward) – factory setting, horizontal (cap up / down)
Protection class:	II (according to EN 60730)
Protection type:	<b>IP 54</b> (according to EN 60529) with top cover
Standards:	CE conformity, low-voltage directive 2014 / 35 / EU
Tests:	DVGW (according to DIN 1854), VDE 0630, EN 61058, directive on gas devices 2009 / 142 / EU, CE 0085 A P 0918

**FUNCTION**  
Contact 1-2 breaks when pressure / differential pressure rises to the preset value.  
Contact 1-3 closes when pressure / differential pressure drops and can be used as signal contact.

**ACCESSORIES**

<b>ASD-06</b>	<b>Connection set</b> (nipple straight) – (included in the scope of delivery)
<b>DS-MR-K</b>	<b>Mounting ring</b> (included in the scope of delivery)
<b>WS-04</b>	<b>Weather and sun protection hood</b> , 130 x 180 x 135 mm, aus stainless steel <b>V2A</b> (1.4301)

**DS2**  
with mounting ring

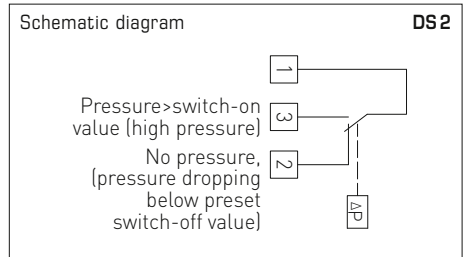

**Dimensional drawing DS2**  
with mounting ring  
**DS-MR-K**

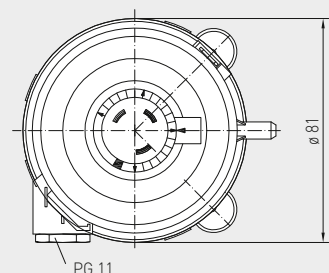
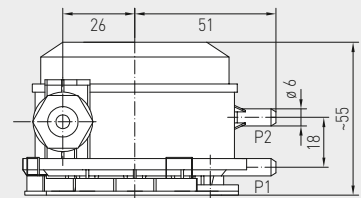
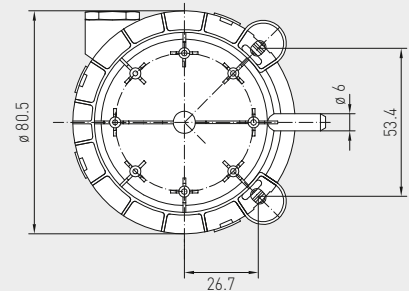

Differential pressure switches for air,  
including connection set

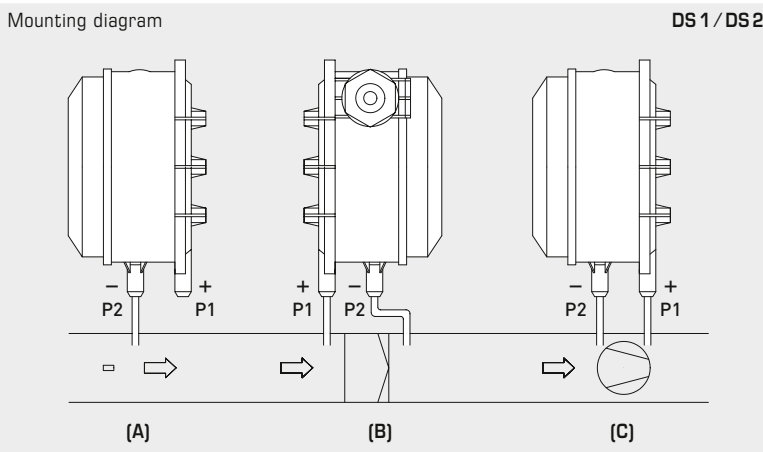
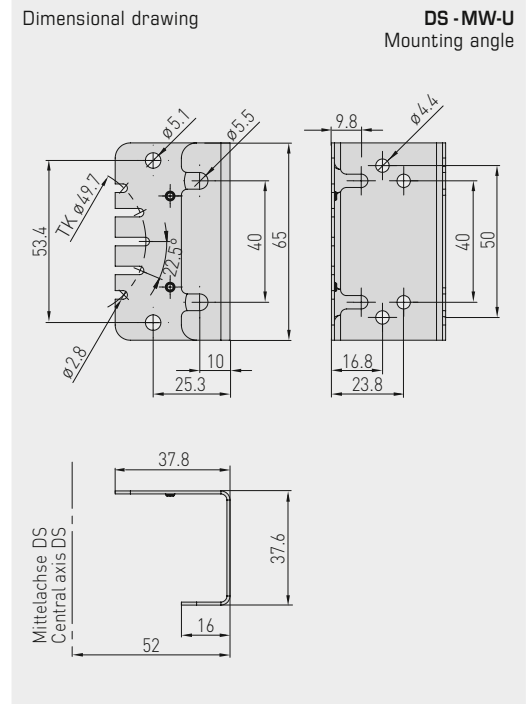
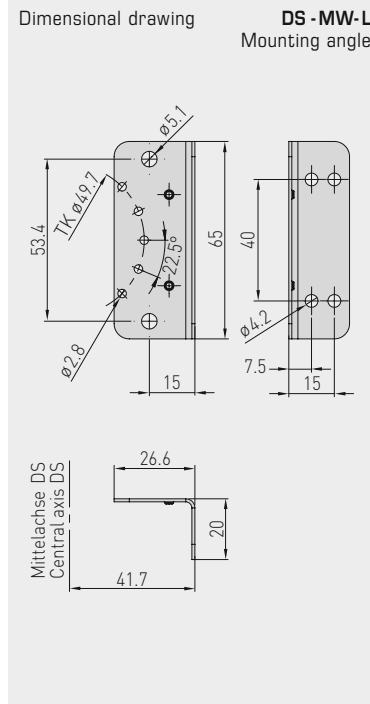
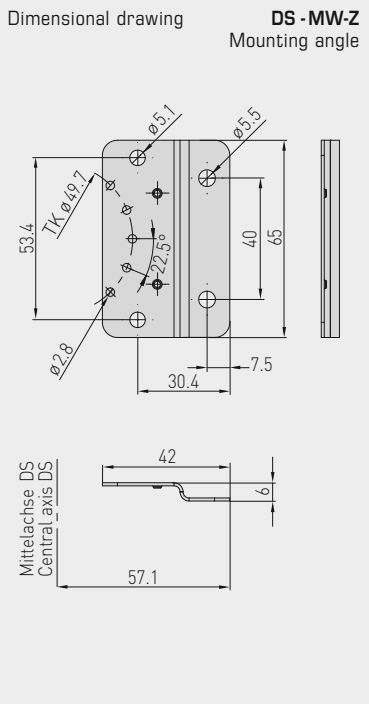

**TYPES OF MONITORING:**

- (A) Below-atmospheric pressure:**  
P1 (+) is not connected but open against atmosphere  
P2 (-) connected to inside of duct
  - (B) Filter:**  
P1 (+) connected upstream of filter  
P2 (-) connected downstream of filter
  - (C) Ventilator:**  
P1 (+) connected downstream of ventilator  
P2 (-) connected upstream of ventilator
- Pressure connections at the pressure switch are marked with P1 (+) for higher pressure and P2 (-) for lower pressure.

**Conversion table for pressure values:**

Unit =	bar	mbar	Pa	kPa	mWS
1 Pa	0.00001 bar	0.01 mbar	1 Pa	0.001 kPa	0.000101971 mWS
1 kPa	0.01 bar	10 mbar	1000 Pa	1 kPa	0.101971 mWS
1 bar	1 bar	1000 mbar	100000 Pa	100 kPa	10.1971 mWS
1 mbar	0.001 bar	1 mbar	100 Pa	0.1 kPa	0.0101971 mWS
1 mWS	0.0980665 bar	98.0665 mbar	9806.65 Pa	9.80665 kPa	1 mWS

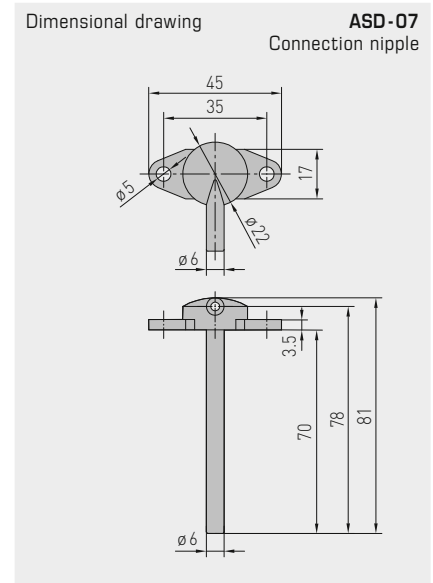
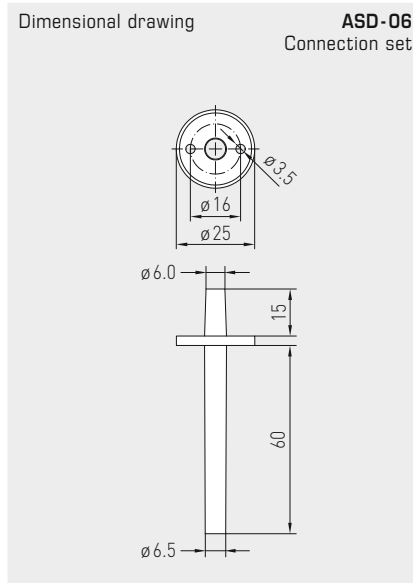
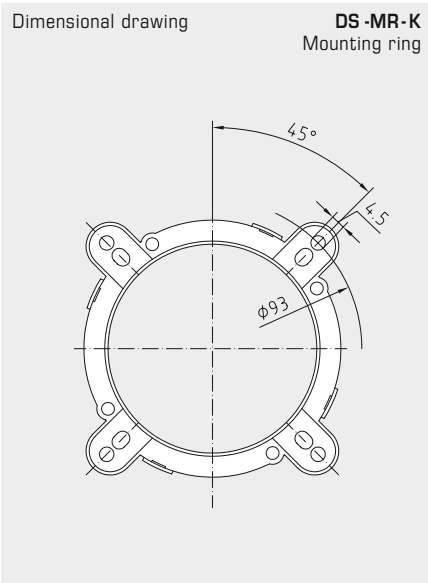

**PREMASREG® DS 1** Differential pressure switches with mounting angle, *Premium*  
**PREMASREG® DS 2** Differential pressure switches with mounting ring, *Standard*

Type	Pressure range (adjustable)	Operating Difference approx.	Max. Pressure	Item No.	Price
<b>DS 1 / WG02</b>	<i>Premium</i>			<b>with mounting angle DS-MW-Z</b>	
DS-106	20... 300 Pa (0.2...3.0 mbar)	0.1 mbar ± 15%	5000 Pa (50 mbar)	1302-4011-0000-000	<b>50,67 €</b>
DS-106 A	50... 500 Pa (0.5...5.0 mbar)	0.2 mbar ± 15%	5000 Pa (50 mbar)	1302-4012-0000-000	<b>50,67 €</b>
DS-106 B	100... 1000 Pa (1.0...10.0 mbar)	0.4 mbar ± 15%	5000 Pa (50 mbar)	1302-4013-0000-000	<b>50,67 €</b>
DS-106 C	500...2000 Pa (5.0...20.0 mbar)	1.0 mbar ± 15%	5000 Pa (50 mbar)	1302-4014-0000-000	<b>50,67 €</b>
DS-106 D	1000...5000 Pa (10.0...50.0 mbar)	2.5 mbar ± 15%	7500 Pa (75 mbar)	1302-4015-0000-000	<b>50,67 €</b>
<b>DS 2 / WG03B</b>	<i>Standard</i>			<b>with mounting ring DS-MR-K</b>	
DS-205 F	20... 300 Pa (0.2...3.0 mbar)	0.1 mbar ± 15%	5000 Pa (50 mbar)	1302-4026-0000-000	<b>33,44 €</b>
DS-205 B	50... 500 Pa (0.5...5.0 mbar)	0.2 mbar ± 15%	5000 Pa (50 mbar)	1302-4022-0000-000	<b>33,44 €</b>
DS-205 D	100... 1000 Pa (1.0...10.0 mbar)	0.4 mbar ± 15%	5000 Pa (50 mbar)	1302-4027-0000-000	<b>33,44 €</b>
DS-205 E	500...2000 Pa (5.0...20.0 mbar)	1.0 mbar ± 15%	5000 Pa (50 mbar)	1302-4028-0000-000	<b>33,44 €</b>
<b>ACCESSORIES</b>					
<b>DS-MW-Z</b>	Sheet steel mounting angle in Z-form ( <b>DS 1: included in the scope of delivery</b> )			7100-0063-0000-000	<b>12,72 €</b>
<b>DS-MW-L</b>	Sheet steel mounting angle in L-form			7100-0063-1000-000	<b>13,02 €</b>
<b>DS-MW-U</b>	Sheet steel mounting angle in U-form			7100-0060-9000-000	<b>16,01 €</b>
<b>ASD-06</b>	Connection set (included in the scope of delivery), consisting of 2 connection nipples (straight) made of ABS, 2 m PVC hose (soft, UV-resistant) and 4 screws			7100-0060-3000-000	<b>7,28 €</b>
<b>ASD-07</b>	2 connection nipples (at 90 degree angle) made of plastic, ABS			7100-0060-7000-000	<b>7,28 €</b>
<b>WS-04</b>	Weather and sun protection hood, 130 x 180 x 135 mm, stainless steel V2A (1.4301)			7100-0040-7000-000	<b>35,70 €</b>

For further information, see last chapter Accessories!

Pressure measuring transducers, incl. DIN plug-in connectors, with active output

The pressure sensor **PREMASGARD® SHD-SD** is used for measuring relative pressures (min. 0...6 bar / max. 0...16 bar) in gaseous and liquid media. **Not suitable for ammonia and freon!**

The pressure sensor **PREMASGARD® SHD** is used for measuring relative pressures (min. 0...1 bar / max. 0...40 bar) in gaseous and liquid media. The pressure measuring cell is welded to the pressure sensors without a gasket.

The pressure measuring transducer converts the measurand into a standard signal of 0-10 V or 4...20 mA. Process connection is G 1/2". This pressure transmitter is used in hydraulics, pneumatics, process technology, in mechanical and plant engineering.

**SHD xx**  
with display  
(optional)



TECHNICAL DATA	
Power supply:	24 V AC / DC for output 0-10 V 7 - 33 V DC for output 4...20 mA
Measuring ranges:	see table (other ranges upon request)
Output:	0-10 V, 3-wire, (working resistance > 10 kOhm) or 4...20 mA, 2-wire, (working resistance < (UB (V)-7 V) / 0,02 A; R <sub>L</sub> depending on working resistance
Electrical connection:	0.25 - 1.5 mm <sup>2</sup> , via plug-in connector DIN EN 175301-803-A (included in the scope of delivery)
Pressure connection:	G 1/2" sealing at the back, and manometer (combined) with profile gasket FPM, special WW G 1/4" DIN 3852
Type of pressure:	relative
Medium:	liquid and gaseous
Response time:	2 ms (1 ms typical)
Characteristic line:	± 0.3%
Mounting:	directly on pressure line
Housing:	stainless steel <b>V2A</b> (1.4305)
Connecting head:	plastic, approx. 98 x 50 x 34 mm
<b>SHD-SD</b>	
Measuring principle:	<b>ceramic measuring cell</b>
Temperature of medium:	-15...+125 °C
Medium contacting parts:	stainless steel <b>V2A</b> (1.4305); measuring element ceramic Al <sub>2</sub> O <sub>3</sub> (96%); sealing material FPM (Viton)
Load changes:	< 100 Hz
Overload range / Bursting pressure:	< 4 bar: 3 x FS > 4 bar: 2.5 x FS
<b>SHD</b>	
Measuring principle:	<b>steel measuring cell</b>
Temperature of medium:	-40...+135 °C
Medium contacting parts:	stainless steel <b>V2A</b> (1.4305)
Overload range:	< 6 bar: 5 x of final valu > 6 bar: 3 x of final valu (max. 1500 bar)
Bursting pressure:	< 6 bar: 10 x of final valu > 6 bar: 6 x of final valu (max. 2500 bar)
Protection class:	III (according to EN 60 730)
Protection type:	<b>IP 65</b> (according to EN 60 529)
Standards:	CE conformity, electromagnetic compatibility according to EN 61 326, EMC directive 2014 / 30 / EU
Tests:	Drinking water approval according to NSF/ANSI 61/372, UL-certified according to ANSI/UL 61010-1
<b>ACCESSORIES</b>	<b>Display module</b> , made of plastic, polyamide material, black colour, extra height: approx. 73 mm, pluggable, <b>factory-calibrated and configured</b> , for displaying the differential pressure (in bar, other units available upon request)

Display module  
(Accessories)

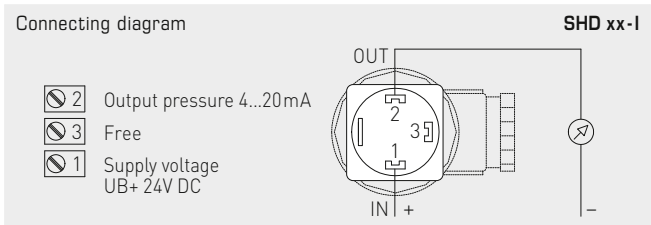
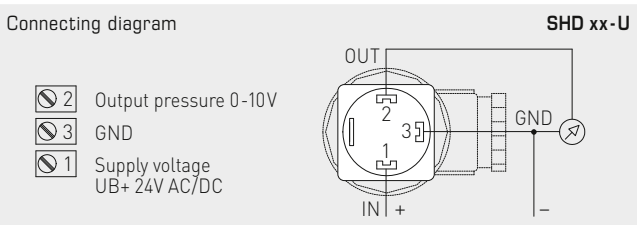



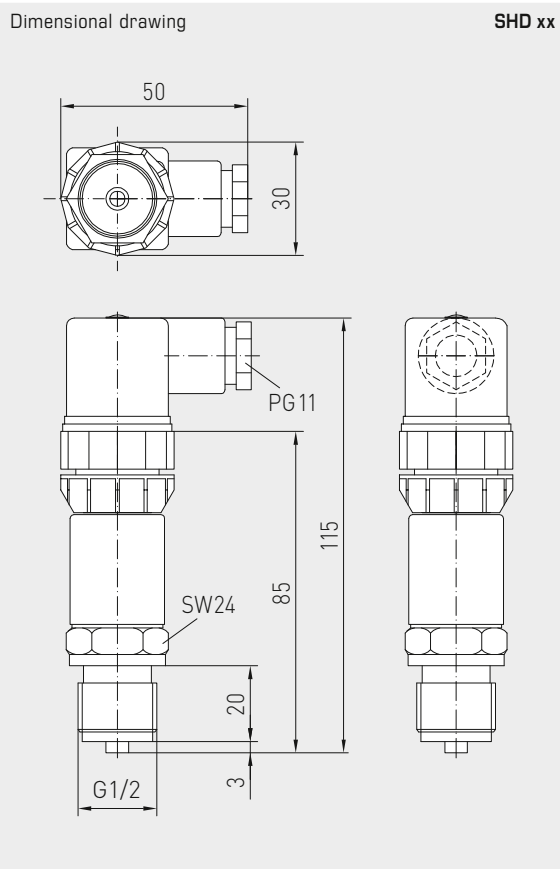

SHD xx  
without display  
(standard)



PREMASGARD® SHD - SD		Pressure measuring transducer, <i>Standard</i> or gaseous and liquid media			
Measuring Range	Type / WG01	Item No.	Type / WG01	Item No.	Price
	<b>SHD-SD-U</b>	U - variant	<b>SHD-SD-I</b>	I - variant	
0... 6 bar	SHD-SD-U 6	1301-2121-0550-120	SHD-SD-I 6	1301-2122-0550-000	123,67 €
0...10 bar	SHD-SD-U 10	1301-2121-0560-120	SHD-SD-I 10	1301-2122-0560-000	123,67 €
0...16 bar	SHD-SD-U 16	1301-2121-0570-120	SHD-SD-I 16	1301-2122-0570-000	123,67 €
<b>Note:</b>	<b>Not suitable for ammonia and freon!</b>				

PREMASGARD® SHD		Pressure measuring transducer, <i>Premium</i> for gaseous and liquid media			
Measuring Range	Type / WG01	Item No.	Type / WG01	Item No.	Price
	<b>SHD-U</b>	U - variant	<b>SHD-I</b>	I - variant	
0... 1 bar	SHD-U 1	1301-2111-0520-220	SHD-I 1	1301-2112-0520-120	204,29 €
0...2,5 bar	SHD-U 2,5	1301-2111-0530-220	SHD-I 2,5	1301-2112-0530-120	204,29 €
0... 6 bar	SHD-U 6	1301-2111-0550-220	SHD-I 6	1301-2112-0550-120	147,91 €
0... 10 bar	SHD-U 10	1301-2111-0560-220	SHD-I 10	1301-2112-0560-120	147,91 €
0... 16 bar	SHD-U 16	1301-2111-0570-220	SHD-I 16	1301-2112-0570-120	147,91 €
0... 25 bar	SHD-U 25	1301-2111-0580-220	SHD-I 25	1301-2112-0580-120	204,29 €
0... 40 bar	SHD-U 40	1301-2111-0590-220	SHD-I 40	1301-2112-0590-120	204,29 €

ACCESSORIES	
<b>LCD-SHD</b>	Display module, factory-calibrated and configured, pluggable, LCD display rotatable and tiltable (in bar, other units available upon request) <span style="float: right;">Extra charge <b>262,02 €</b></span>

**Pressure measuring transducers,  
incl. DIN plug-in connectors,  
with active output**

The pressure sensor / differential pressure sensor **PREMASGARD® SHD 400** is used to measure above-atmospheric, below-atmospheric, and differential pressures in virtually neutral gaseous and liquid media. A rugged and non-sensitive ceramic pressure measuring cell is used. The measuring pressure acts on the ceramic membrane, causing it to deform. This membrane is fitted with a DMS bridge whose resistance value changes in proportion to the degree of deformation. The electronics integrated in the transmitter housing converts this change in resistance into a standard signal of 0-10 V or 4...20 mA. The process connection is implemented via two internal threads G 1/8". It is used in all areas of industrial and sanitary measurement technology, such as differential pressure measurement between the supply and return lines in heating systems or for monitoring filters, fans, and compressors.

**TECHNICAL DATA**

Power supply:	24 V AC / DC (± 20 %)
Measuring ranges:	see table
Output:	0-10 V or 4...20 mA
Permissible working resistance: (at nominal voltage)	R <sub>L</sub> = 2 kΩ for U-variant R <sub>L</sub> = 700 Ω for I-variant
Electrical connection:	0.25 - 1.5 mm <sup>2</sup> , via plug-in connector DIN EN 175301-803-A (included in the scope of delivery)
Pressure connection:	G 1/8" internal thread (optional connection types upon request)
Type of pressure:	differential pressure, above- or below atmospheric pressure
Medium:	liquid or gaseous
Temperature of medium:	-20...+80 °C (non-freezing media)
Mounting:	by 2x M4 screw or fixing plate for wall mounting (installation arbitrary)
Housing:	stainless steel <b>V2A</b> (1.4305)
Medium contacting parts:	ceramic, stainless steel <b>V2A</b> (1.4305), brass, fluorinated rubber
Response time:	< 5 ms
Characteristic line:	< 1 % of final value (at +25 °C)
Overload range:	see table (one-sided max. pressure)
Bursting pressure:	64 bar
Protection class:	III (according to EN 60 730)
Protection type:	<b>IP 65</b> (according to EN 60 529)
Standards:	CE conformity, electromagnetic compatibility according to EN 61 326, EMC directive 2014 / 30 / EU
<b>ACCESSORIES</b>	
<b>VSD-xx-VA / ms</b>	Fitting set, made of stainless steel VA or brass (see table)
<b>WH-400</b>	Fixing plate for wall mounting (wall holder)

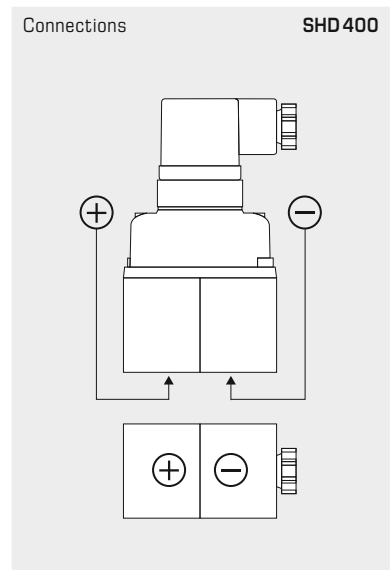

A plus and minus symbol etched on the housing identifies the side on which the respective pressure connection is to be connected below:  
(+) for higher pressure  
(-) for lower pressure



Schematic diagram **SHD400**

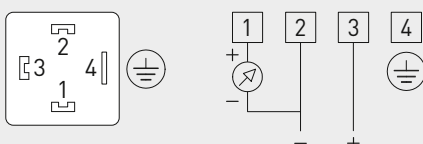

Connecting diagram **SHD400-U**

- 1 Output pressure 0-10V
- 2 UB- GND
- 3 UB+ 24V AC/DC
- 4 GND

Connecting diagram **SHD400-I**

- 1 Output pressure 4...20mA
- 2 UB- GND
- 3 UB+ 24V AC/DC
- 4 GND

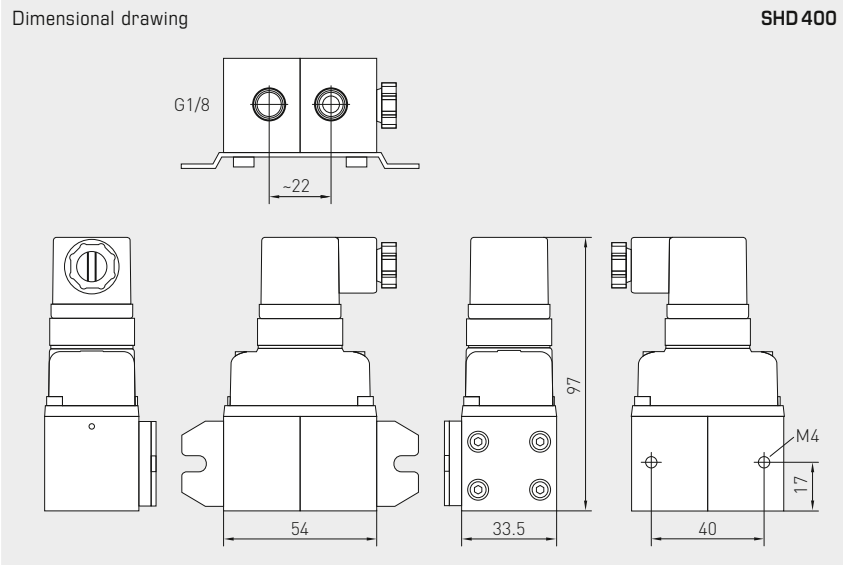

SHD 400

VSD-06-VA  
Fitting set  
(optional)



WH-400  
Wall holder  
(optional)



**PREMASGARD® SHD 400** Pressure measuring transducers, *Standard* for gaseous and liquid media

Type / WG01	Measuring Range	One-sided max. pressure (+)	One-sided max. pressure (-)	System pressure	Output	Item No.	Price
<b>SHD400-U</b>						U - variant	
SHD 400 U VA 2	0... 2 bar	10 bar	5 bar	16 bar	0-10 V	1301-4131-0850-139	351,28 €
SHD 400 U VA 4	0... 4 bar	21 bar	15 bar	16 bar	0-10 V	1301-4131-0540-139	351,28 €
SHD 400 U VA 6	0... 6 bar	21 bar	15 bar	16 bar	0-10 V	1301-4131-0550-139	351,28 €
SHD 400 U VA 10	0...10 bar	25 bar	25 bar	45 bar	0-10 V	1301-4131-0560-139	351,28 €
<b>SHD400-I</b>						I - variant	
SHD 400 I VA 2	0... 2 bar	10 bar	5 bar	16 bar	4...20 mA	1301-4132-0850-139	351,28 €
SHD 400 I VA 4	0... 4 bar	21 bar	15 bar	16 bar	4...20 mA	1301-4132-0540-139	351,28 €
SHD 400 I VA 6	0... 6 bar	21 bar	15 bar	16 bar	4...20 mA	1301-4132-0550-139	351,28 €
SHD 400 I VA 10	0...10 bar	25 bar	25 bar	45 bar	4...20 mA	1301-4132-0560-139	351,28 €

**ACCESSORIES**

VSD-06-MS	Fitting set made of brass, 6 mm	7100-0064-1100-000	15,22 €
VSD-08-MS	Fitting set made of brass, 8 mm	7100-0064-1300-000	15,33 €
VSD-06-VA	Fitting set made of stainless steel VA, 6 mm	7100-0064-1200-000	64,96 €
VSD-08-VA	Fitting set made of stainless steel VA, 8 mm	7100-0064-1400-000	74,64 €
WH-400	Fixing plate for wall mounting (wall holder)	7100-0066-0100-000	14,40 €

**Pressure measuring transducers,  
incl. DIN plug-in connectors and mounting angle,  
with active output**

The pressure sensor / differential pressure sensor **PREMASGARD® SHD-692** is used for pressure measurement in gaseous and liquid media. It converts the measurand into standard signals of 0-10 V or 4...20 mA. Process connection is 2 x G 1/8" - 27 NPT internal thread. SHD-692 differential pressure transmitters are used in piping and hydraulic systems, in mechanical and plant engineering as well as in building automation.

**Not applicable for ammonia and Freon!**

**SHD 692**  
with display  
(optional)



**TECHNICAL DATA**

Power supply:	24 V AC (+15% / -10%), 18 - 33 V DC for U-variant 24 V DC (±20%) for I-variant
Measuring ranges:	see table
Output:	0-10 V (3-wire connection) or 4...20 mA (2-wire connection)
Permissible working resistance: (at nominal voltage)	R <sub>L</sub> > 10 kΩ for U-variant R <sub>L</sub> < 600 Ω for I-variant
Electrical connection:	0.25 - 1.5 mm <sup>2</sup> , via plug-in connector DIN EN 175301-803-A (included in the scope of delivery)
Pressure connection:	screw pipe connection for 6 mm pipe (G 1/8" - 27 NPT internal thread)
Type of pressure:	differential pressure
Measuring principle:	<b>ceramic measuring cell</b>
Medium:	liquid or gaseous
Temperature of medium:	-15...+80 °C
Mounting:	by mounting angle (included in the scope of delivery), installation arbitrary
Housing:	stainless steel <b>V2A</b> (1.4305)
Medium contacting parts:	INOX (1.4305), ceramics, sealing material EPDM
Response time:	< 5 ms
Class:	0.5%
Total error:	< 1.3%
Overload range:	see table (one-sided max. pressure)
System pressure:	max. 25 bar (P1 + P2)
Bursting pressure:	1.5 x system pressure
Insulating resistance:	≥ 100 MOhm, at +20 °C (500 V DC)
Protection class:	III (according to EN 60 730)
Protection type:	<b>IP 65</b> (according to EN 60 529)
Standards:	CE conformity, electromagnetic compatibility according to EN 61 326, EMC directive 2014 / 30 / EU
<b>ACCESSORIES:</b>	<b>Display-Modul</b> , made of plastic, polyamide material, black colour, extra height: approx. 73 mm, pluggable, <b>factory-calibrated and configured</b> , for displaying the differential pressure (in bar, other units available upon request)

Dimensional drawing **SHD 692**  
Mounting angle

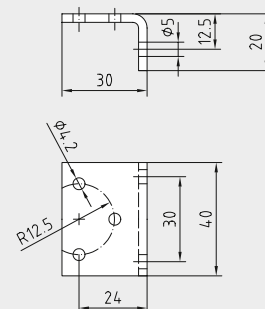

Connecting diagram

**SHD 692-U**

- Output pressure 0-10V
- GND
- Supply voltage UB+ 24V AC / 18-33V DC

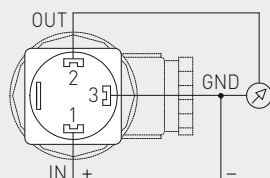

Connecting diagram

**SHD 692-I**

- Output pressure 4...20mA
- Free
- Supply voltage UB+ 24V DC

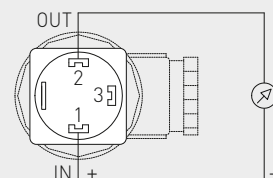

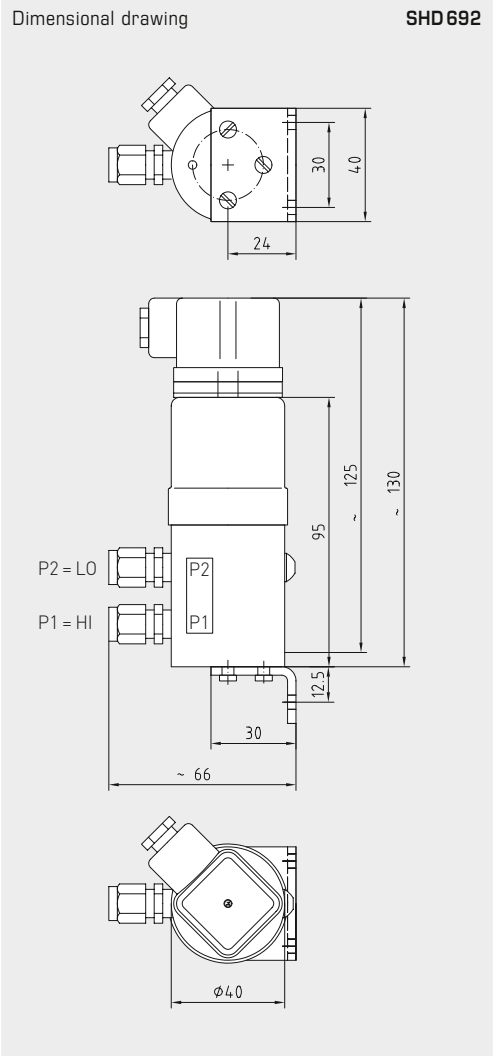

SHD 692 without display (standard)



Display module (Accessories)



PREMASGARD® SHD 692 Pressure measuring transducers, *Deluxe* or gaseous and liquid media

Type / WG02	Measuring Range	One-Sided max. pressure	Output	Item No.	Price
<b>SHD 692-U</b>				U - variant	
SHD 692-U-900	0...0,1 bar	0,6 bar	0-10 V	1301-4121-0500-000	553,28 €
SHD 692-U-907	0...0,5 bar	3 bar	0-10 V	1301-4121-0510-000	553,28 €
SHD 692-U-912	0... 1 bar	5 bar	0-10 V	1301-4121-0520-000	553,28 €
SHD 692-U-916	0...2,5 bar	12 bar	0-10 V	1301-4121-0530-000	553,28 €
SHD 692-U-918	0... 4 bar	12 bar	0-10 V	1301-4121-0540-000	553,28 €
<b>SHD 692-I</b>				I - variant	
SHD 692-I-900	0...0,1 bar	0,6 bar	4...20 mA	1301-4122-0500-000	553,28 €
SHD 692-I-907	0...0,5 bar	3 bar	4...20 mA	1301-4122-0510-000	553,28 €
SHD 692-I-912	0... 1 bar	5 bar	4...20 mA	1301-4122-0520-000	553,28 €
SHD 692-I-916	0...2,5 bar	12 bar	4...20 mA	1301-4122-0530-000	553,28 €
SHD 692-I-918	0... 4 bar	12 bar	4...20 mA	1301-4122-0540-000	553,28 €
<b>Note:</b>	<b>Not applicable for ammonia and freon!</b>				

ACCESSORIES						
<b>LCD-SHD</b>	<b>Display-Modul</b> , factory-calibrated and configured, pluggable, LCD display rotatable and tiltable (in bar, other units available upon request)				Extra charge	<b>262,02 €</b>





## Light Intensity & Motion

**PHOTASGARD®** light intensity sensors and **KINASGARD®** motion or presence detectors are your perfect choice when it comes to saving energy in climatized and security installations.

These S+S solutions keep your costs of lighting, shading, heating and cooling in the “green” range. Incidentally, they also have a perfect fit in presence detection and security zones.

### APPLICATION RANGE

- > Heating, ventilation, air conditioning and lighting systems
- > Greenhouses, shading and solar protection
- > Production facilities and offices in line with occupational health and safety regulations
- > Access control, protected areas and security zones
- > Parking lots, courtyards and corridors



## PHOTASGARD® & KINASGARD®

528 – 547

### Light intensity sensors

<b>AHKF</b>	Outdoor light intensity sensor	<b>535</b>
<b>RHKF</b>	Room light intensity sensor	<b>534</b>
<b>DHKF</b>	In-ceiling light intensity sensor	<b>537</b>

### Motion sensors

<b>ABWF</b>	Outdoor motion sensor	<b>539</b>
<b>RBWF</b>	Room motion sensor	<b>538</b>
<b>DBWF</b>	In-ceiling motion sensor	<b>541</b>
<b>DBWF-C</b>	In-ceiling motion sensor	<b>541</b>

### Light intensity and motion sensors

<b>ABWF/LF</b>	Outdoor motion and light sensor	<b>545</b>
<b>RBWF/LF</b>	Room motion and light sensor	<b>543</b>
<b>DBWF/LF/FTF</b>	In-ceiling motion and light sensor with humidity and temperature sensor	<b>547</b>



# Light Intensity & Motion



## PHOTASGARD® & KINASGARD®

### Multifunctional sensor technology for light and movement

#### Broad Spectrum

Our active motion and light intensity sensors are designed to be multifunctional. This reduces the diversity of types and expands their possible applications. Thanks to microprocessor technology, almost any measuring range can be represented, including custom specifications. Multi-range switching is selectable via DIP switches.

#### Optimum Precision

The devices are tested according to the latest criteria. Each sensor is precisely re-adjustable using offset potentiometers. Take advantage of our experience, our development, manufacturing and product know-how and order these products directly from the manufacturer.

#### Approved Safety



RoHS conforming materials



ESD compliant manufacturing



CE compliance tested by external laboratories

#### Certified Quality



Our development and production in Nuremberg/Germany is certified by TÜV Thüringen according to DIN EN ISO 9001:2015.



GOST certificates



EAC certified

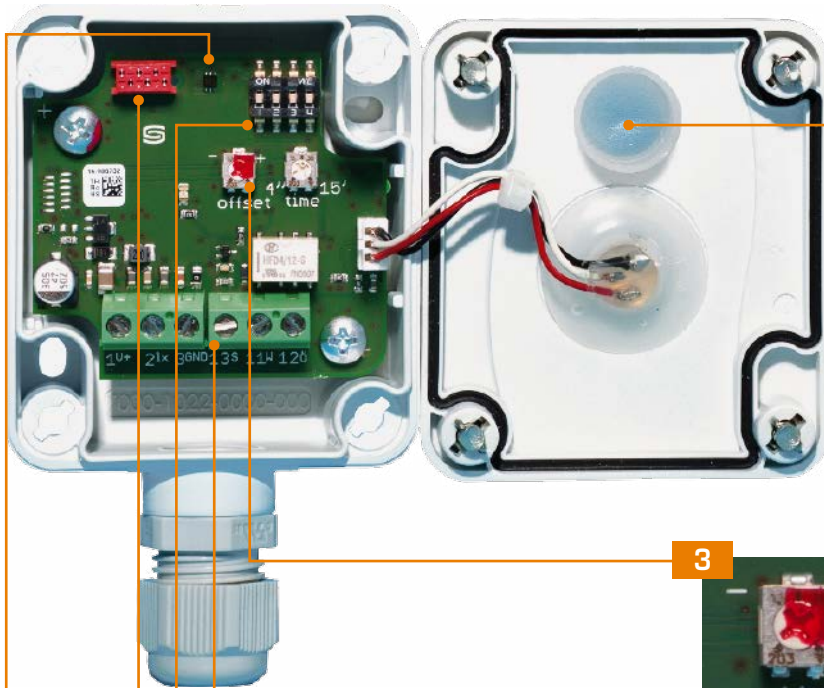

2

### Diffusor

With diffusion and absorption rates specially matched to the light intensity sensor, extends the receiving characteristics over a wider angular range

3



### Offset Potentiometer

For fine adjustment (zero point offset) and readjustment upon recalibration

4



### Screw Terminals

Active output signals 0-10V or 4...20mA

5

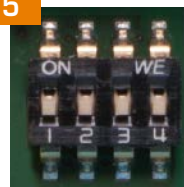

### DIP Switches

For multi-range toggling and setting of 4 measuring ranges:  
 RHKF 0.5 / 1 / 2 / 20 kLux  
 AHKF 0.5 / 1 / 20 / 60 kLux

6



### Quality Assurance

Calibration and balancing are done by means of the bus system

1



### Digital Photo Sensor

With high resolution and resistance to ageing, for a wide linear brightness range of 0-120 kLux

- > Special measuring ranges possible, e.g. for twilight
- > High measuring accuracy with max. < 5 % deviation

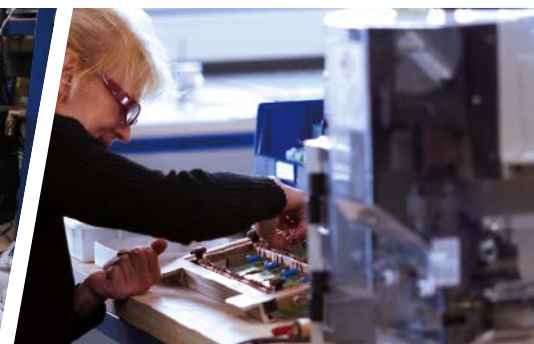



General information  
Light sensor

Light sensor (indoor areas) PHOTASGARD®

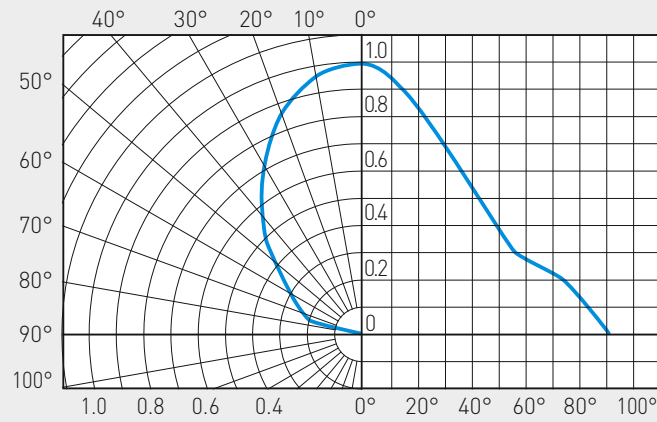

Characteristic curve showing the sensitivity of light sensor (indoor areas) relative to the angle of incidence of light.

Light sensor (outdoor areas) PHOTASGARD®

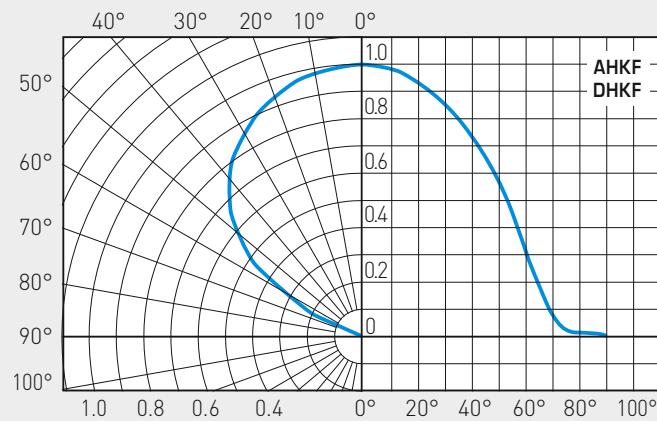

Characteristic curve showing the sensitivity of light sensor (outdoor areas) relative to the angle of incidence of light.

Light sensor (indoor and outdoor areas) PHOTASGARD®

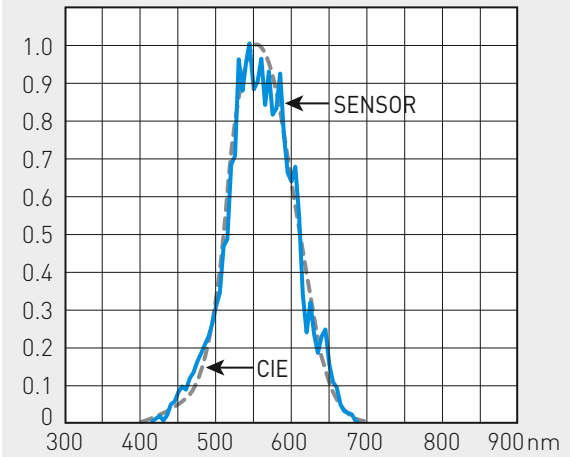

Characteristic curve showing the sensitivity of light sensor on the circuit board in respect of the wavelength of light.

The broken line represents the light perception of the human eye.

The light sensor used in PHOTASGARD® light intensity sensors was specifically adapted to the sensitivity of the human eye. Its greatest sensitivity is in the range of 400nm to 700nm.

With its special filter, the sensor is therefore ideally suited for measuring exposure to daylight and/or for measuring artificial light of high colour temperature (similar to sunlight).





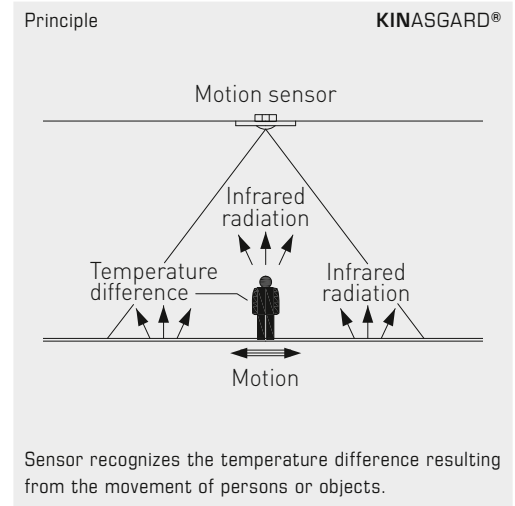
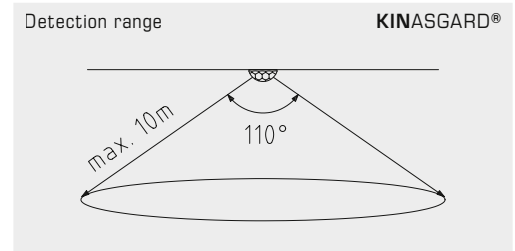
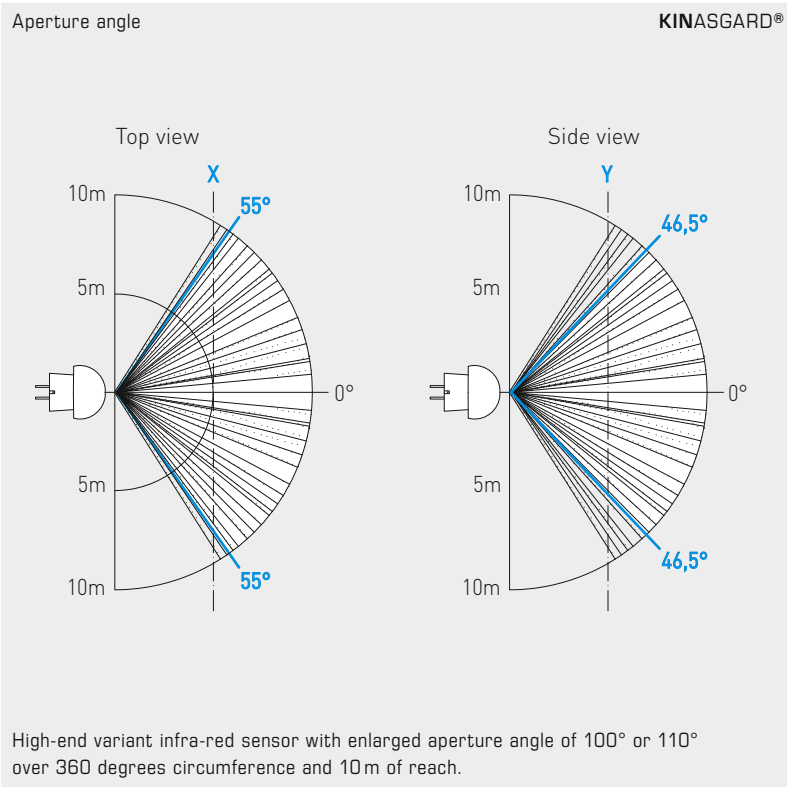

In all **KINASGARD®** motion sensors and presence detectors, a high-end variant infra-red sensor with enlarged angle of aperture is exclusively used.

The patented lens system with 20 individual lenses results in only very small dark areas that are only a few centimetres wide even at a distance of 10 m, thereby reliably detecting small movements.

The sensor recognizes changes in the infra-red radiation spectrum, meaning heat radiation, resulting from the movement of persons or objects.

Such movements generate a temporary change of the temperature gradient in the field.

Due to the constant presence of body (heat) radiation, this sensor is ideally suitable for detecting persons. The temperature difference between sensor and object must be >5 K.

**Room light intensity sensors  
with multi-range switching  
and active output**

The room light intensity sensor **PHOTASGARD® RHKF** with four switchable measuring ranges (four devices in one) measures the luminous intensity with a diffuser and is used to control luminaries, lighting systems, Venetian blinds and canvas blinds, etc., to monitor lighting conditions at workplaces, in storage halls, workshops and corridors, in indoor areas, in industrial halls, in offices as well as in residential and business facilities, for daylight-dependant constant light control, as light intensity or twilight sensor and to control sunshade equipment avoiding unnecessary heating-up of rooms. Therefore it minimizes your variety of types and stock keeping while covering a greater range of universal applications. The sensor used in PHOTASGARD® light intensity sensors was specifically adapted to the sensitivity of the human eye. Its greatest sensitivity is in the range of 400nm to 700nm. With its special filter, the sensor is therefore ideally suited for measuring exposure to daylight and/or for measuring artificial light of high colour temperature (similar to sunlight).

RHKF



**TECHNICAL DATA**

Power supply:	24 V AC (±20%); 15...36 V DC for U variant 15...36 V DC for I variant, depending on working resistance, residual ripple stabilised ±0.3V
Working resistance:	$R_a \text{ (ohm)} = (U_b - 14 \text{ V}) / 0.02 \text{ A}$ for I variant
Load resistance:	$R_L > 5 \text{ kOhm}$ for U variant
Power consumption:	< 1 W at 24 V DC; < 2 VA at 24 V AC
Sensor:	light sensor with diffuser (see beginning of this chapter)
Measuring ranges:	<b>multi-range switching</b> (via DIP switches) <b>0...500 Lux / 1 kLux / 5 kLux / 20 kLux</b> (other individual ranges optional, e. g. 100 kLux)
Output:	4...20mA or 0-10V (2- or 3-wire connection)
Deviation:	typically < 5% of final value
Ambient temperature:	0...+50°C
Electrical connection:	0.14 - 1.5 mm², via terminal screws
Housing:	plastic, material ABS, colour pure white (similar to RAL 9010)
Dimensions:	85 x 85 x 27 mm (Baldur 1)
Installation:	wall mounting or on in-wall flush box, Ø55mm, base with 4-hole for mounting on vertically or horizontally installed in-wall flush boxes for cable entry from the back, with predetermined breaking point for on-wall cable entry from top/bottom in case of plain on-wall installation
Protection class:	III (according to EN 60 730)
Protection type:	<b>IP 30</b> (according to EN 60 529)
Standards:	CE conformity, electromagnetic compatibility according to EN 61 326, EMC directive 2014 / 30 / EU

Measuring ranges [selectable]	DIP 1	DIP 2	DIP 3	DIP 4
0...500 Lux	ON	OFF	OFF	OFF
0... <b>1 kLux</b> (default)	OFF	ON	OFF	OFF
0... 5 kLux	OFF	OFF	ON	OFF
0... 20 kLux	OFF	OFF	OFF	ON

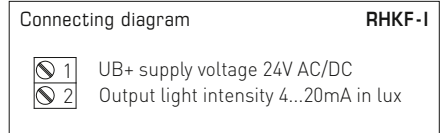
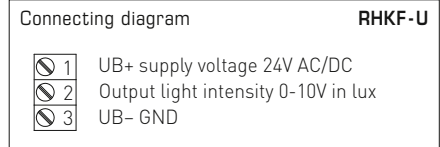

Dimensional drawing

Housing **Baldur 1**  
**RHKF**

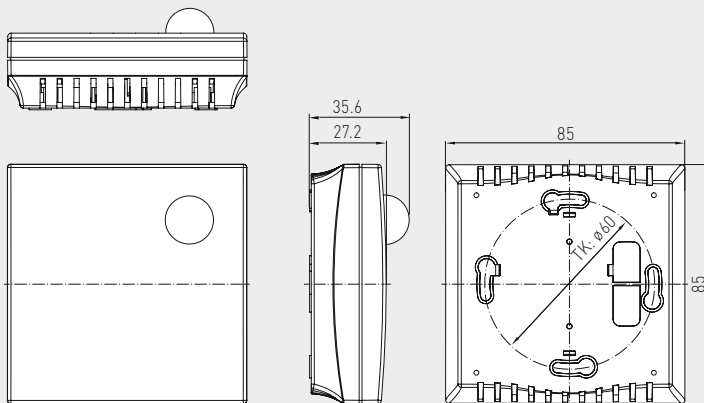

Schematic diagram **RHKF**

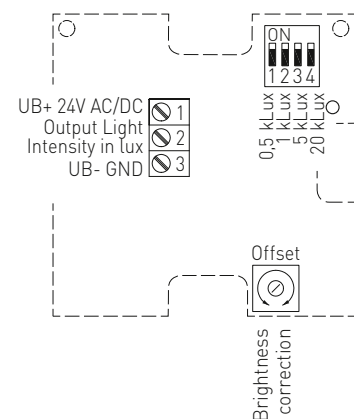

**PHOTASGARD® RHKF** Room light intensity sensors

Type/WG01	Measuring Range Light Intensity (adjustable)	Output Light Intensity	Item No.	Price
<b>RHKF</b>				
RHKF-I	0...500 Lux / 1 kLux / 5 kLux / 20 kLux	4... 20mA	1601-41A2-2000-000	<b>95,98 €</b>
RHKF-U	0...500 Lux / 1 kLux / 5 kLux / 20 kLux	0-10V	1601-41A1-2000-000	<b>95,98 €</b>
Extra charge:	Other individual measuring ranges optional, e. g. 100 kLux		on request	



The light intensity sensor / twilight sensor **PHOTASGARD® AHKF** with six switchable measuring ranges (six devices in one) measures the luminous intensity and is used to control luminaries, lighting systems, Venetian blinds and canvas blinds, etc., to monitor lighting conditions at workplaces, in greenhouses, storage halls, workshops, corridors, in outdoor areas, in industrial halls, in offices as well as in residential and business facilities, for daylight-dependant constant light control, as light intensity or twilight sensor and as sun protection control to avoid unnecessary room heating. Therefore it minimizes your variety of types and stock keeping while covering a greater range of universal applications. The sensor used was specifically adapted to the sensitivity of the human eye. Its greatest sensitivity is in the range of 400 nm to 700 nm. With its special filter, the sensor is therefore ideally suited for measuring exposure to daylight and / or for measuring artificial light of high colour temperature (similar to sunlight).

TECHNICAL DATA	
Power supply:	24 V AC (±20%); 15...36V DC for U variant 15...36V DC for I variant, depending on working resistance, residual ripple stabilised ±0.3 V
Working resistance:	$R_a \text{ (ohm)} = (U_0 - 14 \text{ V}) / 0.02 \text{ A}$ for I variant
Load resistance:	$R_L > 5 \text{ kOhm}$ for U variant
Power consumption:	< 1 W at 24 V DC; < 2 VA at 24 V AC
Sensor:	light sensor (see beginning of this chapter)
Measuring ranges:	<b>multi-range switching</b> (via DIP switches) <b>0...500 Lux / 1 kLux / 2 kLux / 5 kLux / 20 kLux / 60 kLux</b> (other individual ranges optional, e. g. 100 kLux)
Output:	4...20 mA or 0-10 V (2- or 3-wire connection)
Deviation:	typically < 5% of final value
Ambient temperature:	-30...+70 °C
Electrical connection:	0.14 - 1.5 mm <sup>2</sup> , via terminal screws
Housing:	plastic, UV-resistant, material polyamide, 30% glass-globe reinforced, with quick-locking screws (slotted / Phillips head combination), colour traffic white (similar to RAL9016), Housing cover is transparent!
Housing dimensions:	72 x 64 x 43.3 mm (Tyr 1)
Cable connection:	<b>cable gland</b> , plastic (M 16 x 1.5; with strain relief, exchangeable, inner diameter 10.4 mm) or <b>M12 connector</b> (optional on request)
Installation:	on-wall
Protection class:	III (according to EN 60 730)
Protection type:	<b>IP 67</b> (according to EN 60 529) housing tested, TÜV SÜD, report no. 713139052 (Tyr 1)
Standards:	CE conformity, electromagnetic compatibility according to EN 61 326, EMC directive 2014 / 30 / EU



AHKF

Measuring ranges (selectable)	DIP 1	DIP 2	DIP 3	DIP 4
0...500 Lux	OFF	OFF	OFF	-
0... 1 kLux	<b>ON</b>	OFF	OFF	-
0... 2 kLux	OFF	<b>ON</b>	OFF	-
0... 5 kLux	<b>ON</b>	<b>ON</b>	OFF	-
0... <b>20 kLux</b> (default)	OFF	OFF	<b>ON</b>	-
0... 60 kLux	<b>ON</b>	OFF	<b>ON</b>	-

Connecting diagram **AHKF-U**

- 1 UB+ supply voltage 24V AC/DC
- 2 Output light intensity 0-10V in lux
- 3 UB- GND

Connecting diagram **AHKF-I**

- 1 UB+ supply voltage 24V AC/DC
- 2 Output light intensity 4...20mA in lux

Dimensional drawing **AHKF**

M12 connector (optional on request)

Schematic diagram **AHKF**

PHOTASGARD® AHKF Outdoor light intensity sensors / twilight sensors				
Type / WG01	Measuring Range Light Intensity (adjustable)	Output Light Intensity	Item No.	Price
<b>AHKF</b>				
AHKF-I	0...500 Lux / 1 / 2 / 5 / 20 / 60 kLux	4 ... 20 mA	1601-1112-1000-000	<b>95,98 €</b>
AHKF-U	0...500 Lux / 1 / 2 / 5 / 20 / 60 kLux	0-10V	1601-1111-1000-000	<b>95,98 €</b>
Extra charge:	Other individual measuring ranges optional, e. g. 100 kLux		on request	

**In-ceiling light intensity sensors,  
with multi-range switching  
and active output**

**DHKF**  
Connecting head,  
pluggable

The light-intensity sensor **PHOTASGARD® DHKF** with six switchable measuring ranges (six devices in one) for installation in suspended ceilings. The connecting head is pluggable for quick and easy mounting. The measuring transducer is accommodated in a separate housing.

The sensor used was specifically adapted to the sensitivity of the human eye. Its greatest sensitivity is in the range of 400nm to 700nm. With its special filter, the sensor is therefore ideally suited to exposure measurement of daylight and/or for measuring artificial light of high colour temperature (similar to sunlight).

It is used for daylight-dependent constant light control, to control luminaires, lighting systems, Venetian blinds and canvas blinds, and to control light intensity and sun protection hoods to avoid unnecessary heating-up of rooms. It is used in greenhouses, storage halls, industrial halls, workshops, corridors, residential and commercial buildings.



**TECHNICAL DATA**

Power supply:	24 V AC (±20%); 15...36 V DC for U variant 15...36 V DC for I variant, depending on working resistance, residual ripple stabilised ±0.3V
Working resistance:	$R_a \text{ (ohm)} = (U_b - 14 \text{ V}) / 0.02 \text{ A}$ for I variant
Load resistance:	$R_L > 5 \text{ kOhm}$ for U variant
Power consumption:	< 1 W at 24 V DC; < 2 VA at 24 V AC
Sensor:	light sensor (see beginning of this chapter)
Measuring ranges:	<b>multi-range switching</b> (via DIP switches) <b>0...500 Lux / 1 kLux / 2 kLux / 5 kLux / 20 kLux / 60 kLux</b> (optional other individual measuring ranges, e. g. 100 kLux)
Output:	4...20 mA or 0-10 V
Deviation:	typically < 5 % of final value
Ambient temperature:	-30...+70 °C
Housing:	plastic, UV-resistant, material polyamide, 30 % glass-globe reinforced, with quick-locking screws (slotted / Phillips head combination), colour traffic white (similar to RAL 9016)
Housing dimensions:	72 x 64 x 37,8 mm (Tyr 1)
Electrical connection:	2- or 3-wire (see connecting diagram), 0.14 - 1.5 mm <sup>2</sup> , via terminal screws
Cable connection:	<b>cable gland</b> , plastic (M 16 x 1.5; with strain relief, exchangeable, inner diameter 10.4 mm) <b>or</b> <b>M12 connector</b> according to DIN EN 61076-2-101 (optional on request)
Connecting cable:	PVC, LiYY, 4 x 0.14 mm <sup>2</sup> , cable length (KL) = approx. 2 m
Connecting head:	made of plastic, material polycarbonate (PC), colour white, <b>pluggable</b> , Ø = approx. 35 mm, H = approx. 29 mm
Mounting (sensor):	in the suspended ceiling, ceiling cut-out Ø = 30 mm, cover Ø = < 35 mm
Protection type:	<b>IP 67</b> (according to EN 60 529) Housing tested, TÜV SÜD, Report No. 713139052 (Tyr 1) <b>IP 30</b> (according to EN 60 529) Sensor in the built-in state
Protection class:	III (according to EN 60 730)
Standards:	CE conformity, electromagnetic compatibility according to EN 61 326, EMC directive 2014 / 30 / EU

Measuring ranges (adjustable)	DIP 1	DIP 2	DIP 3
0...500 Lux	OFF	OFF	OFF
0... 1 kLux	<b>ON</b>	OFF	OFF
0... 2 kLux	OFF	<b>ON</b>	OFF
0... 5 kLux	<b>ON</b>	<b>ON</b>	OFF
0... <b>20 kLux</b> (default)	OFF	OFF	<b>ON</b>
0... 60 kLux	<b>ON</b>	OFF	<b>ON</b>

Note: **DIP 4, 5, 6** are not assigned!

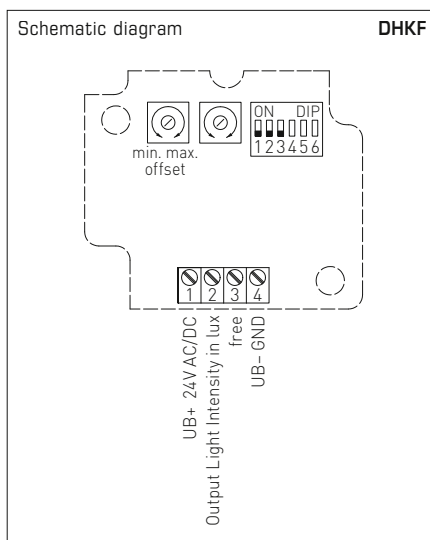
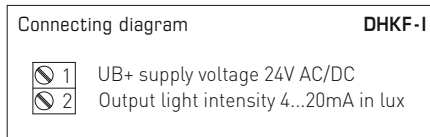
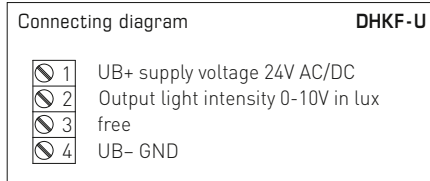

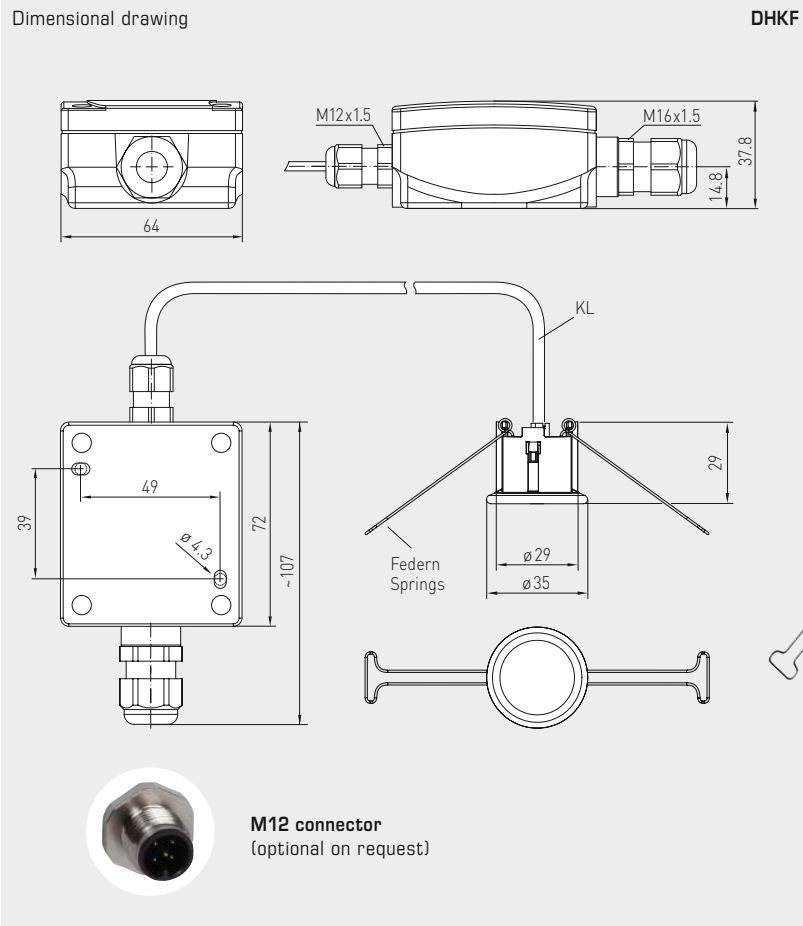

DHKF

PHOTASGARD® DHKF In-ceiling light intensity sensors

Type / WG01	Measuring Range Light Intensity (adjustable)	Output Light Intensity	Item No.	Price
<b>DHKF</b>				
DHKF I	0...500 Lux / 1 / 2 / 5 / 20 / 60 kLux	4 ... 20mA	1601-6122-1000-000	<b>141,15 €</b>
DHKF U	0...500 Lux / 1 / 2 / 5 / 20 / 60 kLux	0-10V	1601-6121-1000-000	<b>141,15 €</b>
Extra charge:	Other individual measuring ranges optional, e. g. 100 kLux		on request	
Optional:	Cable connection with <b>M12 connector</b> according to DIN EN 61076-2-101		on request	



**Room motion sensor  
with switching output**

The motion sensor and presence detector **KINASGARD® RBWF** detects the presence of persons and motions and has a switching output (changeover contact). The sensor detects motions over an aperture angle of 110° and a perimeter of 360°. The patented lens system with 20 individual lenses results in only very small dark areas that are only a few centimetres wide even at a distance of 10 m, thereby reliably detecting small movements. Elegant housing made of plastic with snap-on lid, base with 4-hole attachment for installation on vertically or horizontally installed in-wall flush boxes, with predetermined breaking point for on-wall cable entry in case of on-wall installation. The room motion sensor is used to monitor and recognise conditions and for the motion-dependent control of room functions, e.g. for lowering temperatures in unused rooms as a motion detector. This residential room motion detector is installed in corridors, in outdoor areas, in industrial halls, in offices, in residential rooms and business facilities.

**RBWF**



**TECHNICAL DATA**

Power supply:	24 V AC (± 20%); 15...36 V DC
Power consumption:	< 1 W at 24 V DC; < 2 VA at 24 V AC
Sensor:	infra-red motion sensor (see beginning of this chapter)
Detection range:	perimeter 360°, aperture angle 90° / 110°, reach approx. 10 m, circular
Motion detection:	of persons and objects, necessary temperature difference between subject and surroundings ≥ 5 K
Output:	without / with motion + presence, potential-free changeover contact (24 V), 1 A ohmic load
After-running time:	adjustable from 4 s to 16 min
Ambient temperature:	0...+50 °C
Electrical connection:	0.14 - 1.5 mm², via terminal screws
Housing:	plastic, material ABS, colour pure white (similar to RAL 9010)
Dimensions:	85 x 85 x 27 mm (Baldur 1)
Mounting:	wall mounting or on in-wall flush box, Ø 55 mm, base with 4-hole for mounting on vertically or horizontally installed in-wall flush boxes for cable entry from the back, with predetermined breaking point for on-wall cable entry from top / bottom in case of plain on-wall installation
Protection class:	III (according to EN 60 730)
Protection type:	<b>IP 30</b> (according to EN 60 529)
Standards:	CE conformity, electromagnetic compatibility according to EN 61 326, EMC directive 2014 / 30 / EU

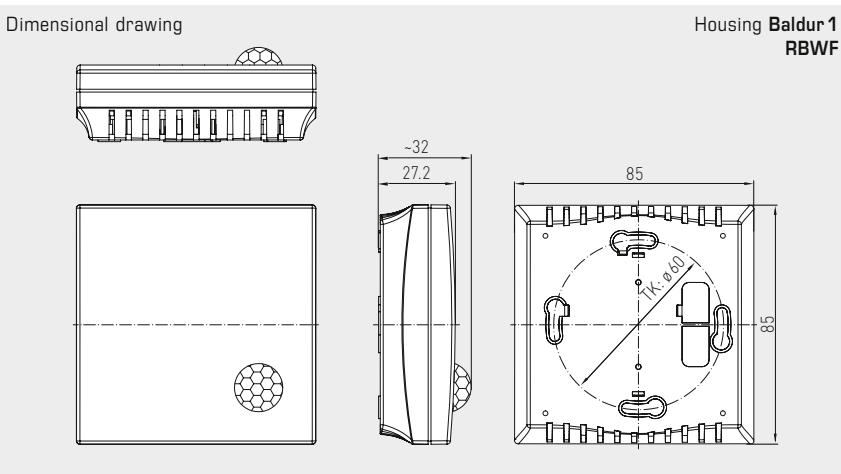
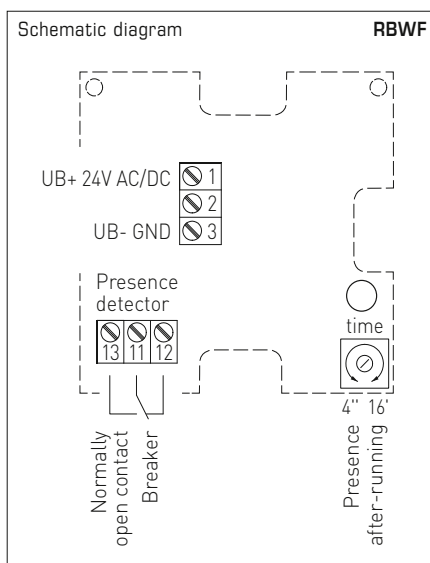
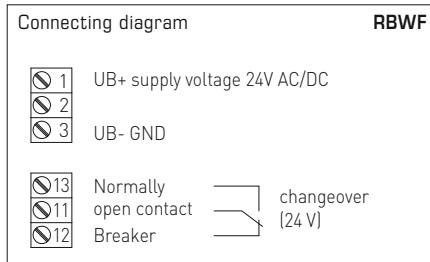

KINASGARD® RBWF Room motion sensor				
Type / WG01	Detection	Output	Item No.	Price
<b>RBWF</b>	Presence + Motion	Presence + Motion		
RBWF-W	Yes / No (relay on / off)	Changeover contact	1401-41A0-4000-000	<b>103,66 €</b>



The motion sensor and presence detector **KINASGARD® ABWF** detects the presence of persons and motions. It is used to observe and recognise conditions and for motion-dependent control of room functions, e.g. as a motion detector to lower temperatures in unused rooms. The motion sensor is used in corridors, in outdoor areas, in industrial halls, in offices, residential rooms and business facilities. The sensor detects motions over an aperture angle of 110° and a perimeter of 360°. The patented lens system with 20 individual lenses results in only very small dark areas that are only a few centimetres wide even at a distance of 10 m, thereby reliably detecting small movements. The sensor recognizes changes in the infra-red radiation spectrum, so in heat radiation, resulting from the movement of persons or objects. Such movements generate a temporary change of the temperature gradient in the field. Due to the constant presence of body (heat) radiation, this sensor is ideally suitable for detecting persons. The temperature difference between sensor and object must be > 5K.

ABWF



TECHNICAL DATA	
Power supply:	24 V AC (± 20 %); 15...36 V DC
Power consumption:	< 1 W at 24 V DC; < 2 VA at 24 V AC
Sensor:	infra-red motion sensor (see beginning of this chapter)
Detection range:	perimeter 360°, aperture angle 90° / 110°, reach approx. 10 m, circular
Motion detection:	of persons and objects, required temperature difference between subject and surroundings ≥ 5 K
Output:	without / with motion + presence, potential-free changeover contact (24 V), 1 A ohmic load
After-running time:	adjustable from 4 s to 16 min
Ambient temperature:	-10...+50 °C
Electrical connection:	0.14 - 1.5 mm², via terminal screws
Housing:	plastic, UV-resistant, material polyamide, 30 % glass-globe reinforced, with quick-locking screws (slotted / Phillips head combination), colour traffic white (similar to RAL 9016)
Housing dimensions:	72 x 64 x 37.8 mm (Tyr 1)
Cable connection:	<b>cable gland</b> , plastic (M 16 x 1.5; with strain relief, exchangeable, inner diameter 10.4 mm) <b>or M12 connector</b> (optional on request)
Installation:	on-wall
Protection class:	III (according to EN 60 730)
Protection type:	<b>IP 65</b> (according to EN 60 529) housing tested, TÜV SÜD, report no. 713139052 (Tyr 1)
Standards:	CE conformity, electromagnetic compatibility according to EN 61 326, EMC directive 2014 / 30 / EU

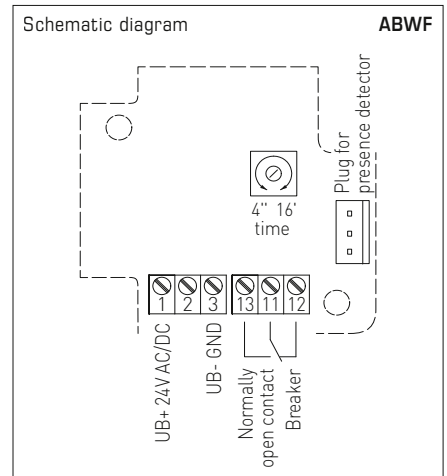
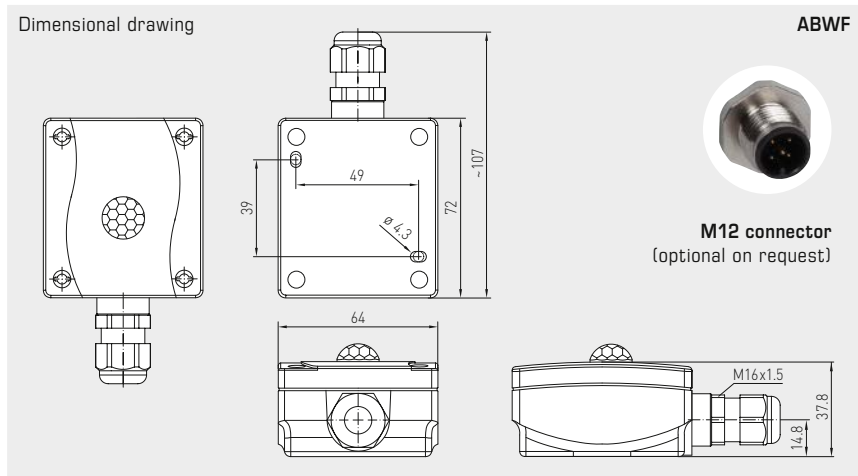
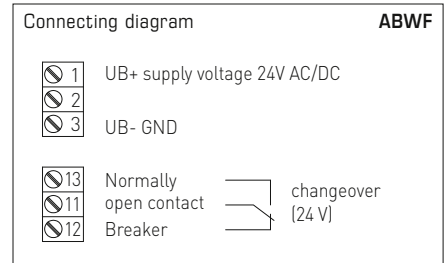

KINASGARD® ABWF Outdoor motion sensor				
Type / WG01	Detection	Output	Item No.	Price
ABWF	Presence + Motion	Presence + Motion		
ABWF-W	Yes / No (relay on / off)	Changeover contact	1401-1110-4000-000	123,64 €

**In-ceiling motion sensor  
with switching output**

The in-ceiling motion sensor and presence detector **KINASGARD® DBWF / DBWF-C** detects the presence of persons and movements and has a switching contact as an output. It has been designed for monitoring and detecting statuses and for motion-dependent control of room functions, e.g. for lowering the temperature of unused rooms.

The in-ceiling motion sensor is used for installation in suspended ceilings in corridors, offices, as well as in residential and business facilities. The connecting head is pluggable for quick, easy mounting. The measuring transducer is accommodated in a separate housing. The sensor detects motions over an aperture angle of 110° and a perimeter of 360°. The patented lens system with 20 individual lenses results in only very small dark areas that are only a few centimetres wide even at a distance of 10 m, thereby reliably detecting small movements.

**DBWF  
DBWF-C**  
connecting head,  
pluggable



**TECHNICAL DATA**

Power supply:	24 V AC (± 20 %); 15...36 V DC
Power consumption:	< 1 W at 24 V DC; < 2 VA at 24 V AC
Sensor:	infra-red motion sensor (see beginning of this chapter)
Detection range:	perimeter 360°, aperture angle 90° / 110°, reach approx. 10 m, circular, at an installation height of approx. 3 m the sensor covers a detection radius (r) of approx. 3.4 m
Motion detection:	of persons and objects, necessary temperature difference between subject and surroundings ≥ 5 K
After-running time:	adjustable from 4 seconds to 16 minutes
Ambient temperature:	-10...+50 °C
Connecting head:	plastic, material polycarbonate (PC), colour white, <b>pluggable</b>
Connecting cable:	PVC, LiYY, 4 x 0.14 mm <sup>2</sup> , cable length (KL) = approx. 2 m
Electrical connection:	0.14 - 1.5 mm <sup>2</sup> via terminal screws
Mounting (sensor):	in the suspended ceiling, ceiling cutout Ø = 30 mm, cover Ø = < 35 mm
Protection type (sensor):	<b>IP 30</b> (according to EN 60 529) in the built-in state
Protection class (sensor):	III (according to EN 60 730)
Standards:	CE-conformity, electromagnetic compatibility according to EN 61 326, EMC Directive 2014 / 30 / EU

**DBWF measuring transducer**

Output:	potential-free <b>changeover contact</b> (24 V), 1 A ohmic load
Housing:	plastic, UV-resistant, material polyamide, 30% glass-globe reinforced, with quick-locking screws (slotted / Phillips head combination), colour traffic white (similar to RAL 9016)
Housing dimensions:	72 x 64 x 37.8 mm (Tyr 1)
Cable connection:	<b>cable gland</b> , plastic (M 16 x 1.5; with strain relief, exchangeable, inner diameter 10.4 mm) <b>or</b> <b>M12 connector</b> according to DIN EN 61076-2-101 (optional on request)
Protection type (housing):	<b>IP 67</b> (according to EN 60 529) housing tested, TÜV SÜD, report no. 713139052 (Tyr 1)

**DBWF-C measuring transducer**

Output:	potential-free <b>normally open contact</b> , signal relay, max. 24 V / 0.5 A
Housing:	plastic, material PVC, colour black
Housing dimensions:	55 x 20 x 15 mm (compact form)
Protection type (housing):	<b>IP 20</b> (according to EN 60 529) (compact form)

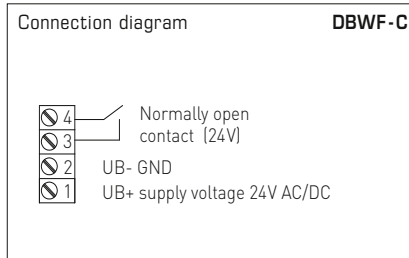
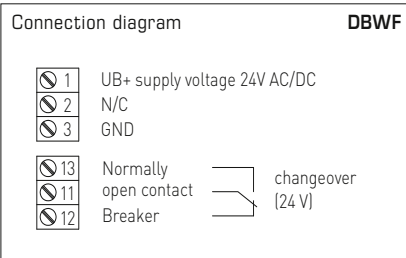
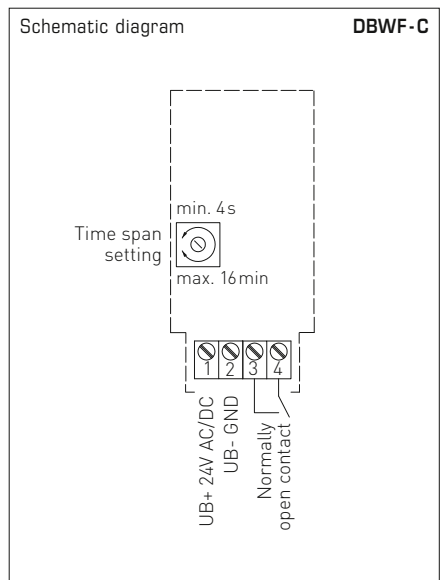
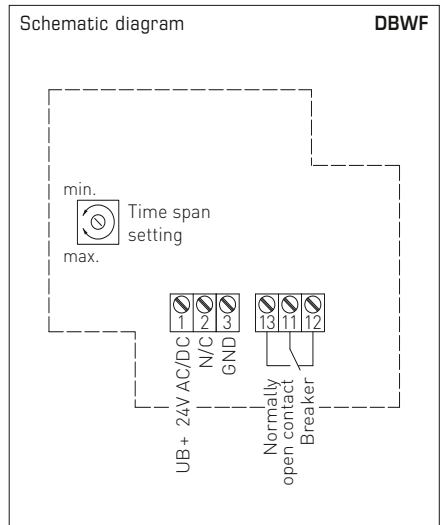

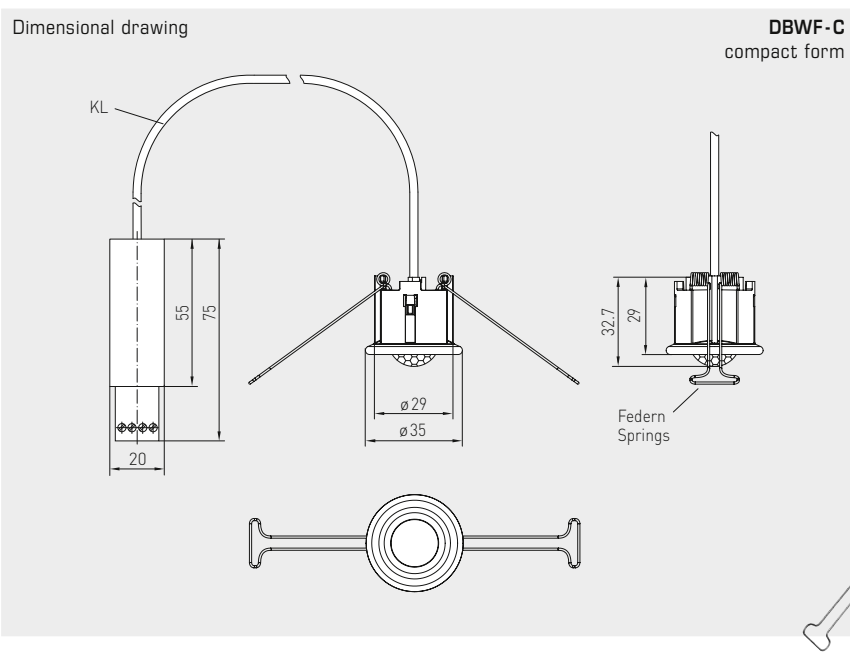
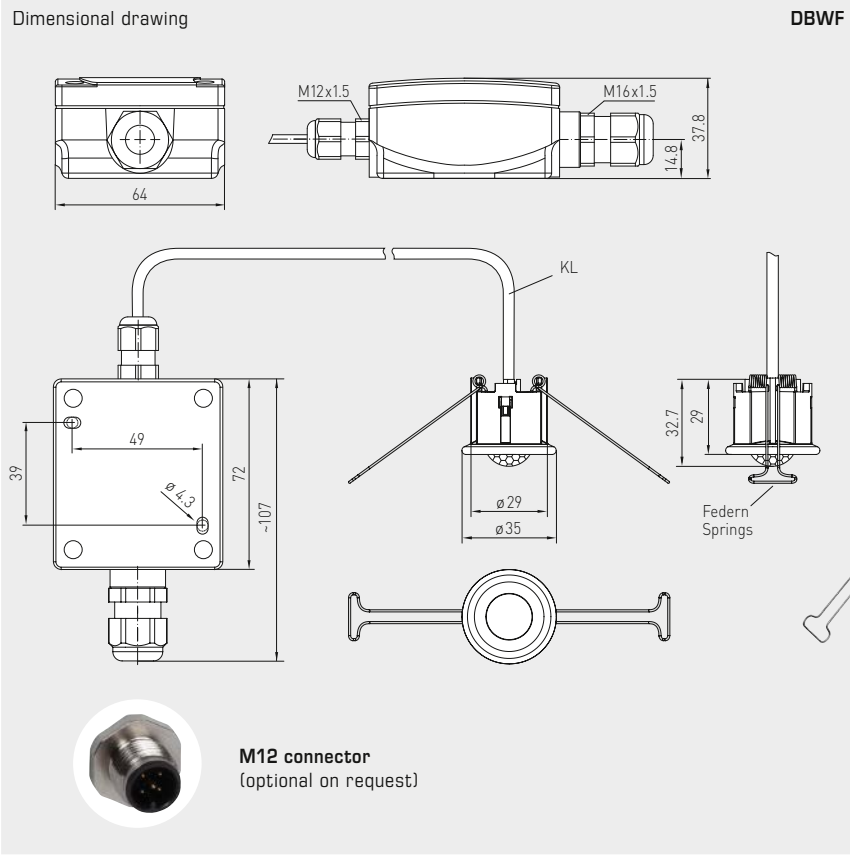

Type / WG01	Detection	Output	Item no.	Price
KINASGARD® DBWF	In-ceiling motion sensor			
KINASGARD® DBWF-C	In-ceiling motion sensor, compact form			
	Presence + Movement	Presence + Movement		
<b>DBWF</b>				
DBWF-W	Yes / No (relay on / off)	Changeover contact	1401-6120-3000-000	<b>132,44 €</b>
Optional:	Cable connection with <b>M12 connector</b> according to DIN EN 61076-2-101		on request	
<b>DBWF-C</b>				
DBWF-C	Yes / No (relay on / off)	Normally open contact	1401-6130-1000-006	<b>99,03 €</b>

**Room motion sensor and light sensor, multisensors with active and switching output**

The room motion and light sensor and presence detector **KINASGARD® RBWF-LF** is a combined instrument that detects motion and light intensity using a diffuser as well as the presence of persons and is used to recognize conditions. RBWF-LF issues a standard signal of 0-10V or 4...20mA for light intensity and has a switching (normally open contact) output for detecting motion.

This multi-sensor is used in building automation, in corridors, at workplaces, in industrial halls, in offices and business facilities for the control of lighting as needed, e.g. to control sunshade equipment, for daylight-dependant constant light control, for activating Venetian blinds or luminaries, for automatic energy conservation, and to avoid unnecessary heating-up or cooling of unoccupied rooms.

**TECHNICAL DATA**

Power supply:	24V AC (±20%); 15...36V DC for U variant 15...36V DC for I variant, depending on working resistance, residual ripple stabilised ±0.3V
Working resistance:	$R_b(\text{ohm}) = (U_b - 14\text{V}) / 0.02\text{A}$ for I variant
Load resistance:	$R_L > 5\text{kOhm}$ for U variant
Power consumption:	< 1 W at 24 V DC; < 2 VA at 24 V AC
Sensor:	infra-red motion sensor and light sensor with diffuser (see beginning of this chapter)
Output, motion sensor:	without / with motion + presence, potential-free normally open contact (24V), 1 A ohmic load
After-running time:	adjustable from 4 s to 16 min
Measuring ranges:	<b>multi-range switching</b> (via DIP switches) <b>0...500 Lux / 1 kLux / 5 kLux / 20 kLux</b> (other individual ranges optional, e. g. 100 kLux)
Output, light sensor:	0-10V (linearised, active, 3-wire connection) or 4...20mA
Deviation, light sensor:	typically < 5% of final value
Ambient temperature:	0...+50 °C
Electrical connection:	0.14 - 1.5 mm <sup>2</sup> , via terminal screws
Housing:	plastic, material ABS, colour pure white (similar to RAL 9010)
Dimensions:	85 x 85 x 27 mm (Baldur 1)
Installation:	wall mounting or on in-wall flush box, Ø 55 mm, base with 4-hole for mounting on vertically or horizontally installed in-wall flush boxes for cable entry from the back, with predetermined breaking point for on-wall cable entry from top / bottom in case of plain on-wall installation
Protection class:	III (according to EN 60 730)
Protection type:	<b>IP 30</b> (according to EN 60 529)
Standards:	CE conformity, electromagnetic compatibility according to EN 61 326, EMC directive 2014 / 30 / EU

Measuring ranges (selectable)	DIP 1	DIP 2	DIP 3	DIP 4
0...500 Lux	ON	OFF	OFF	OFF
0... 1 kLux (default)	OFF	ON	OFF	OFF
0... 5 kLux	OFF	OFF	ON	OFF
0... 20 kLux	OFF	OFF	OFF	ON

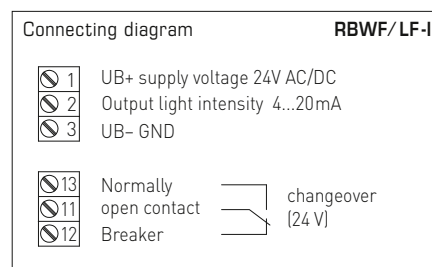
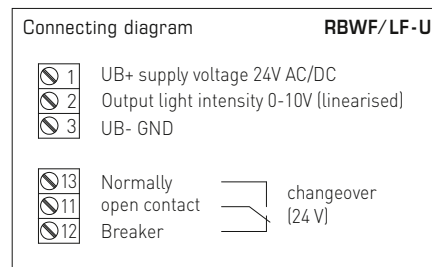
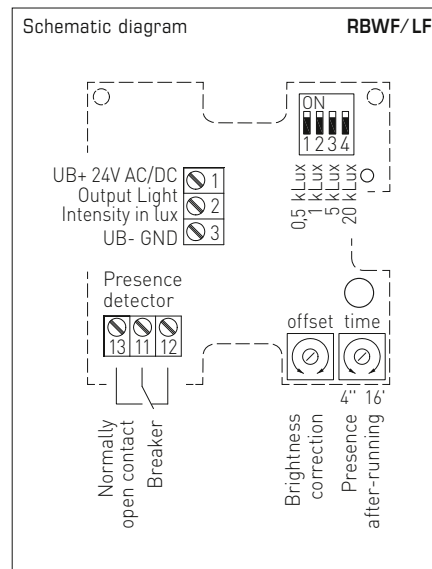





Dimensional drawing

Housing **Baldur 1**  
RBWF/LF

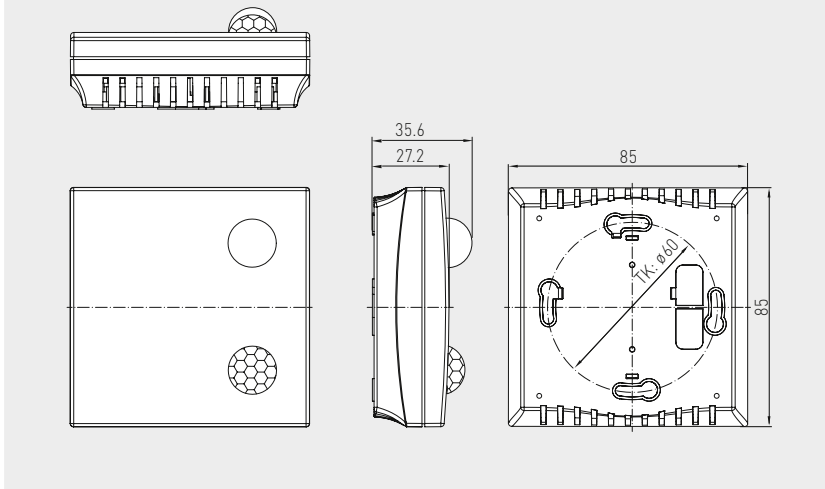

RBWF/LF



**KINASGARD® RBWF/LF** Room motion sensor and light sensor

Type / WG01	Detection, Measuring Range	Output	Item No.	Price
<b>RBWF-LF-U</b>				
1. Presence + Motion	Yes / No (relay on / off)	Changeover contact	1401-41A1-1100-000	<b>157,17 €</b>
2. Light Intensity	0...500 Lux / 1 kLux / 5 kLux / 20 kLux	0 -10V (linearised)		
<b>RBWF-LF-I</b>				
1. Presence + Motion	Yes / No (relay on / off)	Changeover contact	1401-41A1-3200-000	<b>157,17 €</b>
2. Light Intensity	0...500 Lux / 1 kLux / 5 kLux / 20 kLux	4...20 mA		
Extra charge:	Other individual measuring ranges optional, e.g. 100 kLux		on request	



**Outdoor motion sensor and light sensor, multisensors with active and switching output**

The room motion and light sensor and presence detector **KINASGARD® ABWF / LF** is a combined instrument that detects motions and light intensity as well as the presence of persons and is used to recognize conditions. ABWF / LF issues a standard signal of 0-10V or 4...20mA for light intensity and has a switching (changeover contact) output for the detection of motions.

The motion sensor / presence detector detects the presence of persons and motions. It is used to monitor and recognise conditions and for motion-dependent control of room functions, e.g. as a motion detector to lower temperatures in unused rooms. The motion sensor is used in corridors, in outdoor areas, in industrial halls, in offices, residential rooms and business facilities.

The light intensity sensor / twilight sensor with six switchable measuring ranges (six devices in one) measures the luminous intensity and is used to control luminaries, lighting systems, Venetian blinds and canvas blinds, etc., to monitor lighting conditions at workplaces, in greenhouses, storage halls, workshops, corridors, in outdoor areas, in industrial halls, in offices as well as in residential and business facilities, for daylight-dependant constant light control, as light intensity or twilight sensor and to control sunshade equipment avoiding unnecessary heating-up of rooms.

**TECHNICAL DATA**

Power supply:	24 V AC (±20%); 15...36V DC for U variant 15...36V DC for I variant, depending on working resistance, residual ripple stabilised ±0.3V
Working resistance:	$R_a \text{ (ohm)} = (U_b - 14 \text{ V}) / 0.02 \text{ A}$ for I variant
Load resistance:	$R_L > 5 \text{ kOhm}$ for U variant
Power consumption:	< 1 W at 24 V DC; < 2 VA at 24 V AC
Sensor:	infra-red motion sensor and light sensor (see beginning of this chapter)
Output, motion sensor:	without / with motion + presence, potential-free normally open contact (24V), 1 A ohmic load
After-running time:	adjustable from 4 s to 16 min
Measuring ranges:	<b>multi-range switching</b> (via DIP switches) <b>0...500 Lux / 1 kLux / 2 kLux / 5 kLux / 20 kLux / 60 kLux</b> (other individual ranges optional, e. g. 100 kLux)
Output:	0-10 V (linearised, active, 3-wire connection) or 4...20 mA
Deviation, light sensor:	typically < 5 % of final value
Ambient temperature:	-10...+50 °C
Electrical connection:	0.14 - 1.5 mm <sup>2</sup> , via terminal screws
Housing:	plastic, UV-resistant, material polyamide, 30 % glass-globe reinforced, with quick-locking screws (slotted / Phillips head combination), colour traffic white (similar to RAL 9016)
Housing dimensions:	72 x 64 x 37.8 mm (Tyr 1)
Cable connection:	<b>cable gland</b> , plastic (M 16 x 1.5; with strain relief, exchangeable, inner diameter 10.4 mm) <b>or</b> <b>M12 connector</b> according to DIN EN 61076-2-101 (optional on request)
Installation:	on-wall
Protection class:	III (according to EN 60 730)
Protection type:	<b>IP65</b> (according to EN 60 529) housing tested, TÜV SÜD, report no. 713139052 (Tyr 1)
Standards:	CE conformity, electromagnetic compatibility according to EN 61 326, EMC directive 2014 / 30 / EU

Measuring ranges (selectable)	DIP 1	DIP 2	DIP 3	DIP 4
0...500 Lux	OFF	OFF	OFF	-
0... 1 kLux	<b>ON</b>	OFF	OFF	-
0... 2 kLux	OFF	<b>ON</b>	OFF	-
0... 5 kLux	<b>ON</b>	<b>ON</b>	OFF	-
0... <b>20 kLux</b> (default)	OFF	OFF	<b>ON</b>	-
0... 60 kLux	<b>ON</b>	OFF	<b>ON</b>	-

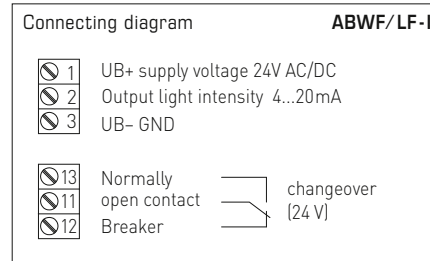
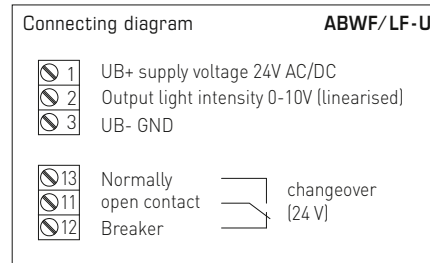
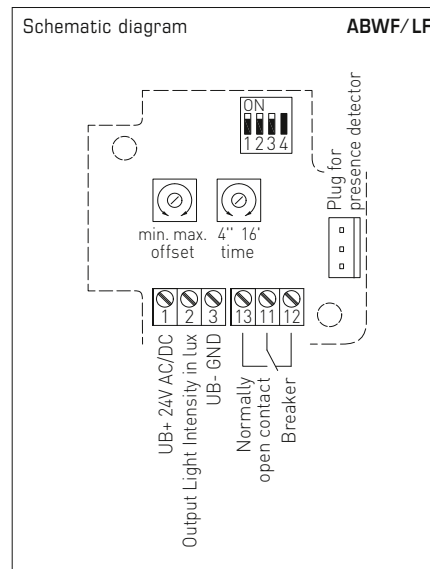

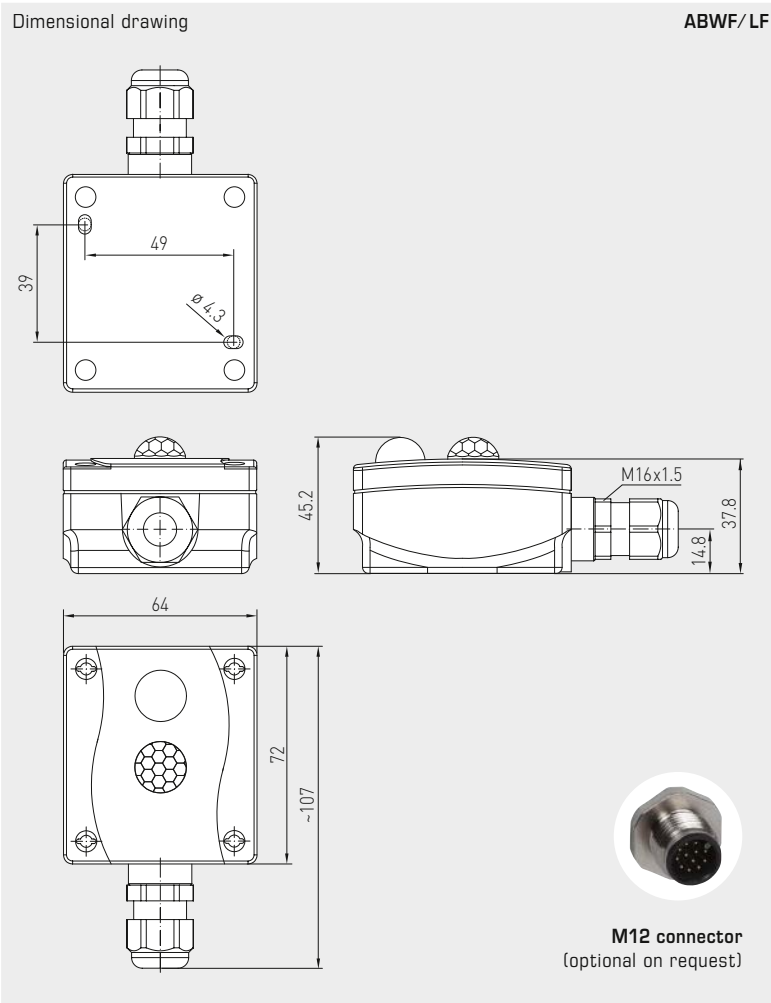

ABWF/LF



KINASGARD® ABWF/LF Outdoor motion sensor and light sensor				
Type / WG01	Detection, Measuring Range	Output	Item No.	Price
<b>ABWF-LF-U</b>				
1. Presence + Motion	Yes / No (relay on / off)	Changeover contact	1401-1111-2100-000	<b>167,00 €</b>
2. Light Intensity	0...500 Lux / 1 / 2 / 5 / 20 / 60 kLux	<b>0 - 10V</b> (linearised)		
<b>ABWF-LF-I</b>				
1. Presence + Motion	Yes / No (relay on / off)	Changeover contact	1401-1111-3200-000	<b>167,00 €</b>
2. Light Intensity	0...500 Lux / 1 / 2 / 5 / 20 / 60 kLux	<b>4...20 mA</b> (linearised)		
Extra charge:	Other individual measuring ranges optional, e. g. 100 kLux		on request	
Optional:	Cable connection with <b>M12 connector</b> according to DIN EN 61076-2-101		on request	

**In-ceiling motion detector, light, humidity and temperature sensor, multisensors with switching output**

The in-ceiling sensor **KINASGARD® DBWF/LF/FTF** is used to detect persons within a distance of up to 10 meters and to measure luminous intensity or brightness, relative humidity and temperature. It has been designed for installation in suspended ceilings.

The sensor detects **motion** over an aperture angle of 110° and a perimeter of 360°. The patented lens system with 20 individual lenses results in only very small dark areas that are only a few centimetres wide even at a distance of 10 m, thereby reliably detecting small movements. If motion is detected, the potential-free relay output is switched. The hold time of the output, measured from the moment of the last detected movement, can be preset internally in the device via potentiometer within a range of 4 seconds to approx. 17 minutes.

For the **temperature and humidity**, an analogue output 0-10 V corresponding to 0...+50 °C or 0...100 % r. H. is available. Deviations due to the mounting position and location can be compensated internally using one offset regulator respectively.

For **luminous intensity or brightness** of 0...1000 lux or 0...5000 lux (selectable via DIP switches), an analogue output 0-10 V is also available. It is also possible to activate the motion output depending on brightness with the help of a jumper.

Fields of application for the DBWF/LF/FTF include residential room monitoring, automatic switching of lights, control technology, alarm technology, and motion-dependent control of room functions, e. g. for lowering the temperature in unused rooms.

**TECHNICAL DATA**

Power supply:	24 V AC / DC (half-wave rectification, read the instructions!)
Power consumption:	< 3.6 VA at 24 V DC
Electrical connection:	0.14 - 1.5 mm <sup>2</sup> , via terminal screws
Outputs:	0-10 V or inverted 10-0V (selectable via DIP switches)
<b>MOTION</b>	
Sensor:	infra-red motion sensor (see beginning of this chapter)
Detection range:	perimeter 360°, aperture angle 90° / 110°, reach approx. 10 m, circular, at an installation height of approx. 3 m the sensor covers a detection radius (r) of approx. 3.4 m
Motion detection:	of persons and objects, necessary temperature difference between subject and surroundings ≥ 5 K
Output, motion sensor:	potential-free changeover contact, for switching safety extra-low voltage only, up to 1 A
After-running time:	adjustable from 4 s to 17 min
<b>LIGHT INTENSITY</b>	
Sensor:	light sensor with diffusor (see beginning of this chapter)
Measuring range, light sensor:	0...1000 lux / 0...5000 lux (selectable via DIP switches)
Output, light sensor:	0- 10V
Deviation, light sensor:	typically < ± 10 % of final value (referred to calibration reference source, approx. 5700K)
Temperature drift:	< ± 5 % of final value / 10K at +20 °C
<b>HUMIDITY</b>	
Measuring range, humidity:	0...100 % r.H. (output corresponding to 0- 10V)
Operating range, humidity:	10...95 % r.H. (non-precipitating air)
Deviation, humidity:	typically ± 3 % r.H. (20...80 %); at +20 °C, otherwise ± 5 % r.H.
Output, humidity:	0-10 V
<b>TEMPERATURE</b>	
Measuring range, temperature:	0...+50 °C (output corresponding to 0- 10V) other measuring ranges on request!
Operating range, temperature:	0...+50 °C
Deviation, temperature:	typically ± 0.8K at +20 °C, under standard conditions
Output, temperature:	0-10 V
Ambient temperature:	0...+50 °C
Storage temperature:	-20...+50 °C
Housing:	steel, white painted
Housing dimensions:	cover: Ø 96 mm, height of housing: 30 mm
Installation dimensions:	ceiling cutout: Ø 80 mm installation depth: < 45 mm (incl. connector system) on-wall protrusion: > 13 mm (motion sensor) > 20 mm (humidity sensor)
Sensor protection:	mounted inside ceiling installation housing
Protection class:	III (according to EN 60 730)
Protection type (housing):	<b>IP 20</b> (according to EN 60 529)
Standards:	CE conformity, electromagnetic compatibility according to EN 61 326, EMC directive 2014 / 30 / EU

<b>Function output</b> (direction adjustable)	<b>DIP 1</b>
<b>normal</b> (default) 0 % = 0V 100 % = 10V	OFF
<b>inverted</b> 0 % = 10V 100 % = 0V	ON

<b>Brightness</b> (adjustable measuring range)	<b>DIP 3</b>
0... <b>1000 Lux</b> (default)	OFF
0... 5000 Lux	ON

<b>Motion</b> (mode selectable)	<b>DIP 4</b>
<b>Motion mode</b> (default) Motion detector is independent of threshold value	OFF
<b>Auto mode</b> If the set threshold value is not reached, the motion detector is active	ON

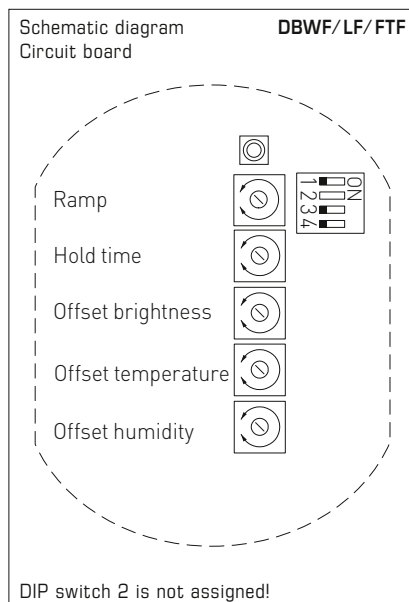

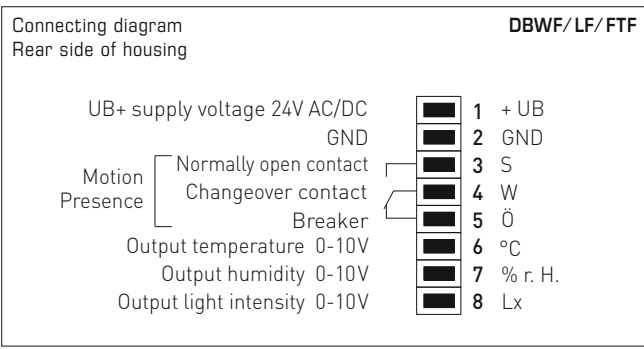
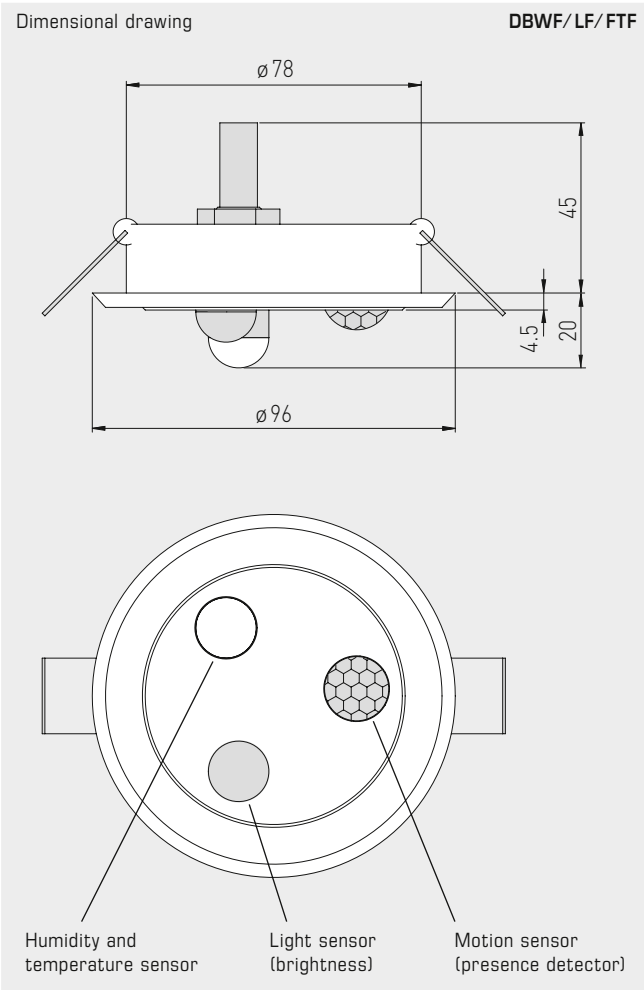

KINASGARD® DBWF/LF/FTF In-ceiling motion, light, temperature and humidity sensor				
Type / WG02	Detection, Measuring Range	Output	Item No.	Price
<b>DBWF-LF-FTF-W</b>				
1. Presence + Motion	yes / no (relay on / off)	Changeover contact	1401-6114-3100-000	<b>224,59 €</b>
2. Light Intensity	0...1000 lux / 0...5000 lux (DIP)	0-10V (linearised)		
3. Temperature	0... 50 °C	0- 10V		
4. Humidity	0...100% r.H.	0- 10V		
Outputs: <b>0-10V or inverted 10-0V</b> (selectable via DIP switches)				





## Air Quality & Flow

Increased CO<sub>2</sub> values, fine dust or VOC pollution are detrimental with regard to energy costs and well-being.

With **AERASGARD**<sup>®</sup> air quality sensors and **RHEASGARD**<sup>®</sup> flow sensors, you can monitor the entire room climate in a controlled way.

And with our **RHEASREG**<sup>®</sup> flow monitors and controllers you are firmly in control of lines carrying air, gas or liquid.

### APPLICATION RANGE

- > Ventilation and air conditioning
- > Ventilator flow monitoring, butterfly valves, heating registers and humidifiers
- > Energy management
- > Residential, working and conference rooms
- > Movie theaters, showrooms and retail stores
- > Institutes and laboratories



## AERASGARD®, RHEASGARD® & RHEASREG®

548 – 605

### CO2 sensors

<b>FSC02</b>	In-wall CO2 sensor	<b>575</b>
<b>FSTM-CO2</b>	In-wall temperature / CO2 sensor	<b>575</b>
<b>RCO2-AS xx</b>	CO2 Room traffic light with signal tone	<b>NEW 561</b>
<b>RCO2-SD</b>	Room CO2 sensor	<b>565</b>
<b>RCO2-W</b>	Room CO2 sensor	<b>565</b>
<b>RTM-CO2-SD</b>	Room temperature CO2 sensor	<b>569</b>
<b>RFTM-CO2-W</b>	Room humidity / temperature / CO2 sensor	<b>569</b>
<b>ACO2-SD</b>	On-wall CO2 sensor	<b>577</b>
<b>ACO2-W</b>	On-wall CO2 sensor	<b>577</b>
<b>ATM-CO2-SD</b>	On-wall temperature / CO2 sensor	<b>583</b>
<b>AFTM-CO2-W</b>	On-wall humidity / temperature / CO2 sensor	<b>583</b>
<b>KCO2-SD</b>	Duct CO2 sensor	<b>593</b>
<b>KCO2-W</b>	Duct CO2 sensor	<b>593</b>
<b>KTM-CO2-SD</b>	Duct temperature / CO2 sensor	<b>599</b>
<b>KFTM-CO2-W</b>	Duct humidity / temperature / CO2 sensor	<b>599</b>

### VOC sensors

<b>RLQ-SD</b>	Room air-quality sensor	<b>557</b>
<b>RLQ-W</b>	Room air-quality sensor	<b>557</b>
<b>KLQ-SD</b>	Duct air-quality sensor	<b>589</b>
<b>KLQ-W</b>	Duct air-quality sensor	<b>589</b>

### Fine dust sensors (PM)

<b>RPS-SD</b>	Room fine dust sensor	<b>NEW 573</b>
<b>RFTM-PS-W</b>	Room humidity / temperature / fine dust sensor	<b>NEW 573</b>
<b>APS-SD</b>	On-wall fine dust sensor	<b>NEW 585</b>

### Multifunctional sensors VOC / CO2 / fine dust (PM)

<b>RLQ-CO2-W</b>	Room air-quality / CO2 sensor	<b>569</b>
<b>RFTM-LQ-CO2-W</b>	Room humidity / temperature / air-quality / CO2 sensor	<b>569</b>
<b>RFTM-PS-CO2-W</b>	Room humidity / temperature / fine dust / CO2 sensor	<b>NEW 573</b>
<b>ALQ-CO2-W</b>	On-wall air-quality / CO2 sensor	<b>583</b>
<b>AFTM-LQ-CO2-W</b>	On-wall humidity / temperature / air-quality / CO2 sensor	<b>583</b>
<b>KLQ-CO2-W</b>	Duct air-quality / CO2 sensor	<b>599</b>
<b>KFTM-LQ-CO2-W</b>	Duct humidity / temperature / air-quality / CO2 sensor	<b>599</b>

### Airflow monitors

<b>KLGF</b>	Duct airflow monitor	<b>601</b>
<b>KLSW</b>	Duct airflow monitor	<b>601</b>
<b>SW</b>	Flow monitor	<b>605</b>
<b>WFS</b>	Wind vane switch	<b>603</b>

### Accessories

see chapter Accessories	<b>644</b>
-------------------------	------------

Note concerning type designation:  
W = with changeover contact



# Air Quality & Flow



## AERASGARD<sup>®</sup>, RHEASGARD<sup>®</sup> & RHEASREG<sup>®</sup> Multifunctional sensor technology for air quality and more

### Broad Spectrum

Our active devices for measuring and regulating CO<sub>2</sub>, gas mixtures (VOC), fine dust (PM) and flows are designed to be multifunctional. This reduces the diversity of types and expands their possible applications. Thanks to microprocessor technology, almost any measuring range can be represented, including custom specifications. DIP switches are used to select functions such as multi-range switching, automatic mode, and manual calibration.

### Optimum Precision

The devices are tested according to the latest criteria. Take advantage of our experience, our development, manufacturing and product know-how and order these products directly from the manufacturer.

### Approved Safety



RoHS conforming materials



ESD compliant manufacturing



CE compliance tested by external laboratories

### Certified Quality



Our development and production in Nuremberg/Germany is certified by TÜV Thüringen according to DIN EN ISO 9001:2015.



GOST certificates



EAC certified





**Optional Display**  
With backlighting

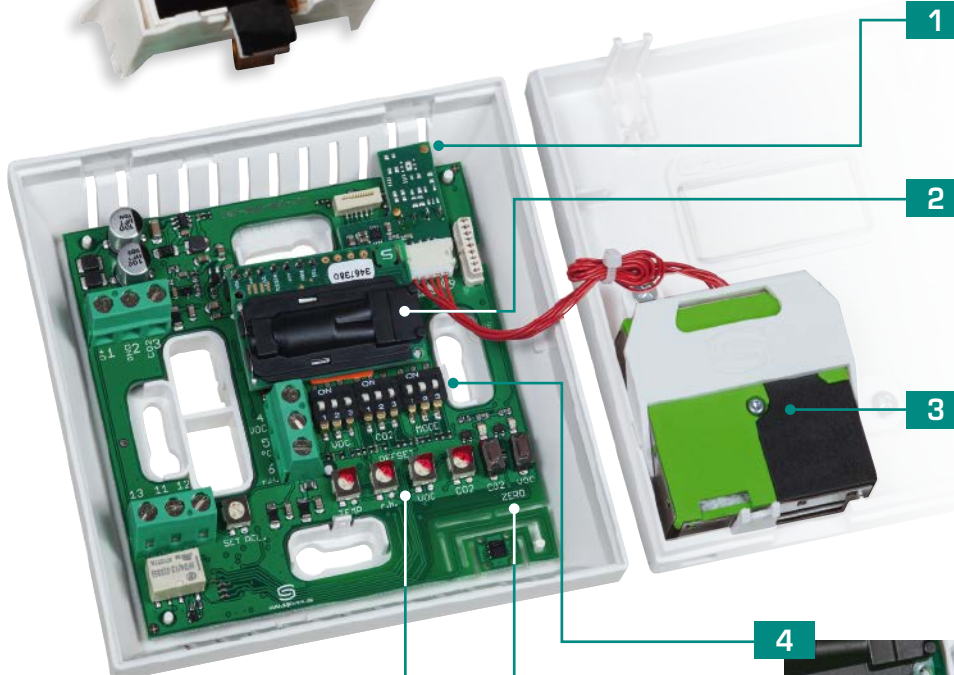

**1 VOC Sensor**  
For mixed gases and air quality

**2 CO2 Sensor**  
Calibration and balancing is done by means of the bus system in climate cabinets

**3 Fine dust sensor (PM)**  
Optical particle sensor with laser and contamination resistance technology

**4 DIP Switches**  
For individual adjustment of measuring ranges, output, automatic zero point and relay assignment

**5 Trigger**  
For CO2 or VOC zero point

**6 Potentiometer**  
For setting the relay thresholds for CO2 and VOC. For setting the offsets for temperature, humidity, CO2 and VOC



**PLEUROFORM™**  
Multi-channel pipe for simultaneous measuring of CO2 and VOC

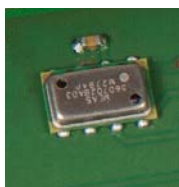

**Air Pressure Compensation**  
Premium duct sensors with barometric air pressure compensation of CO2 readings



## General information

### Atmospheric pressure, measurement methods and compensation

Due to the increasing demands for accuracy, low maintenance, and long-term stability, we have further developed and improved our established switchable measuring system. The new generation of devices now includes two-beam measurement technology and atmospheric pressure compensation for CO<sub>2</sub> measurement.

#### Single-beam measurement method

The single-beam measurement method is particularly suitable for applications where the rooms to be monitored are periodically unoccupied. A prerequisite for reliable measurement results is a regular supply of fresh air – at least three times in seven days. This is the most frequent application.

#### Dual-beam measurement method

The dual-beam measurement method consists of a reference channel and a measuring channel. In this case, the reference channel operates in a spectrum that is not influenced by the CO<sub>2</sub> concentration of the medium. Ageing, soiling, and drifts affect both channels. With the help of these relationships, the phenomena mentioned can be largely offset without having to rely on a supply of fresh air. The dual-beam measurement method is always used if the application involved unusual circumstances – such as rooms that are in continuous use, 24 hours a day, 7 days a week.

#### Compensation

In building automation up to now, compensating for the influence of atmospheric pressure was neglected. Due to low- and high-pressure weather conditions and differing altitudes above sea level, barometric pressure variations of up to  $\pm 100$  mbar can apply. This can result in measurement errors of up to  $\pm 16$  % of the measured value in an uncompensated systems. Our new generation of devices features an integrated atmospheric pressure measurement that compensates CO<sub>2</sub> reading accordingly.





S+S Regeltechnik supplies measuring instruments for CO<sub>2</sub> or VOC measurement in various types of design and, in contrast to other manufacturers, combined devices for CO<sub>2</sub> and VOC measurement with separate sensors for both of these measurands in addition to several switchable measuring ranges.

The most important aspect of ventilation on an as-needed basis is the general room air quality, often also referred to as the "comfort zone". Aside from the generally known and accepted control variables, such as relative humidity and temperature, CO<sub>2</sub> and VOC concentrations in the air are also important parameters to be controlled. Each individual interprets room air and its quality differently.

For that reason, air quality can only be defined in rather general terms. The air must be perceived as pleasant by a majority of people and it must not lead to any discomfort. Air must not contain any hazardous concentrations of pollutants. In this respect, the opinions of persons entering the room are decisive. This is because they soon become accustomed to their surroundings and therefore to the various pollution burdens, which they then no longer notice. An important function of systems for energy-saving ventilation on an as-needed basis is to guarantee good room air quality.

### Carbon dioxide

A measuring system based on NDIR (non-dispersive infra-red sensor) technology for CO<sub>2</sub> measurement consists of a light source and a receptor. A certain range of wavelengths of light radiated by the source is damped and absorbed by CO<sub>2</sub> molecules in the measured section. This damping is detected by the receptor.

In building automation applications, detection of the CO<sub>2</sub> content in air is primarily undertaken to control non-smoking rooms occupied by varying numbers of persons, such as conference rooms, break rooms, cinemas, schools, etc. Here, the increased CO<sub>2</sub> content caused by the presence of persons is interpreted as a "deterioration" of the air quality.

Over the last few years, a standard measuring range of 0...2000 ppm (parts per million) has become established for CO<sub>2</sub> measuring instruments. Although this measuring range covers the recommended maximum CO<sub>2</sub> concentrations for working and residential rooms (1000...1500 ppm), in practice however it became apparent that in many applications the measuring range of 2000 ppm does not suffice. Therefore, we have developed and launched a new generation of devices with switchable upper measuring range limits of 2000 ppm, 5000 ppm, and 10000 ppm.

### Mixed gas VOC

VOC is the abbreviation for Volatile Organic Compounds. According to the definition by the World Health Organization WHO, VOC are organic substances with a boiling range from +60 to +250°C.

Examples of VOCs include compounds of the substance groups alkanes / alkenes, aromatic compounds, terpenes, halogenated hydrocarbons, esters, aldehydes, and ketones. There is a large number of naturally occurring VOCs, some of which are also released into the atmosphere in substantial quantities, e.g. terpenes and isoprene from forests.

Environmental pollution by VOC caused by human activities increased significantly throughout the last century. The biggest contributor is traffic, followed in second place by the construction sector with construction chemistry products such as coating compounds, adhesives, or sealing compounds. Potential sources of VOC in indoor spaces in addition to construction materials include furnishing objects, cleaning and care products, hobby and do-it-yourself products, office chemicals and, above all, tobacco smoke. An essential carrier of VOC is floor carpeting. Odour problems due to VOC can also be caused by microbes, or metabolic substances from bacteria and fungi.

It is precisely these types of substances mentioned and their increased occurrence that are ascertained. Since the air to be monitored contains a multitude of different substances to which the sensor reacts and since gas mixtures are forming, this sensor does not function selectively but reflects the overall air quality. Also the statement as to what constitutes "good air" or "bad air" cannot be definitively made, as this is an entirely subjective sensation. Ventilation is recommended starting from a value between 60 - 80 % VOC.

The sensor alters its conductivity depending on the concentration, the nature, and the mixture ratio of reducing molecules in ambient air.

### CO<sub>2</sub> and/ or VOC?

The above explanations demonstrate that there are applications for CO<sub>2</sub> measurement, for VOC measurement, but from our perspective, above all, for a combination of both measurands. The crucial factor in this respect is that both of these measurands are not convertible into each other and derivations to or from one another cannot be made. A NDIR CO<sub>2</sub> measuring instrument measures selectively and cannot detect any VOC, a VOC mixed gas sensor cannot recognize CO<sub>2</sub> molecules.

The new duct sensor featuring the Tyr2 housing design with PLEUROFORM™ multi-channel pipe handles this separation perfectly, can record both CO<sub>2</sub> concentration as well as VOC mixed gas (or gas pressure) and, if necessary, can function as a genuine multifunctional device that delivers humidity and temperature data.

**Room air quality sensor (VOC) and measuring transducer, self-calibrating, with multi-range switching and active/switching output**

Maintenance-free room sensor **AERASGARD® RLQ - SD** with active output, automatic calibration, in an elegant plastic housing with snap-on lid, for determining the air quality (0...100% VOC). The measuring transducer converts the measured values into a standard signal of 0-10 V or 4...20 mA (switchable).

Maintenance-free room sensor **AERASGARD® RLQ - W** with active/switching output, automatic calibration in an elegant plastic housing with snap-on lid, optional with traffic light indicator (five coloured LEDs), for determining the air quality (0...100% VOC). The measuring transducer converts the measured values into a standard signal of 0-10 V or 4...20 mA (switchable).

The sensor is used in offices, hotels, convention centres, apartments, shops, etc. for the purpose of evaluating the indoor climate. This enables energy-saving room ventilation on an as-needed basis, thereby reducing operating costs and improving well-being.

The air quality is detected by a **VOC sensor** (mixed gas sensor for volatile organic substances). This sensor determines the loading of the room air due to contaminated gases such as cigarette smoke, body perspiration, exhaled breathing air, solvent vapours, emissions, etc. With regard to the expected air contamination, low, medium or high VOC sensitivity can be selected. As an alternative, use IAQ categories (from excellent to unhealthy) following the guidelines of the German Federal Environmental Agency to assess the room air.

For more information, see the start of the chapter.

**RLQ - W  
RLQ - SD**



**TECHNICAL DATA**

Power supply:	24 V AC / DC (± 10 %)
Power consumption:	< 1.5 W / 24 V DC typical; < 2.9 VA / 24 V AC typical
Sensor:	VOC sensor (metal oxide) (VOC = volatile organic compounds),, with manual calibration (via zero button), with automatic calibration (permanently active)
Measuring range:	0...100% air quality; referred to calibrating gas; <b>multi-range switching</b> (selectable via DIP switches) VOC sensitivities (low/medium/high) or IAQ category (Indoor Air Quality)
Output:	(0 V = clean air, 10 V = polluted air) <b>RLQ - SD</b> 0 -10 V (fixed) <b>RLQ - W</b> 0 -10 V or 4...20 mA, working resistance < 800 Ω (selectable via DIP switches), with offset potentiometer (± 10 % of the measuring range)
Relay output:	<b>RLQ - SD</b> without changeover contact <b>RLQ - W</b> with potential-free <b>changeover contact</b> (24 V / 1 A) (switchpoint can be adjusted from 0...100 % of the output signal)
Measuring accuracy:	typically ± 20 % of final value (referred to calibrating gas)
Service life:	> 60 months (under normal load conditions), depending on the type of loading and gas concentration
Gas exchange:	by diffusion
Ambient temperature:	0...+ 50 °C
Warm-up time:	approx. 1 hour
Response time:	approx. 1 minute
Electrical connection:	0.14 - 1.5 mm <sup>2</sup> , via screw terminals
Housing:	plastic, material ABS, colour pure white (similar to RAL 9010), optional stainless steel <b>V2A</b> (1.4301)
Dimensions:	85 x 85 x 27 mm (Baldur 1) 100 x 100 x 25 mm (stainless steel)
Installation:	wall mounting or on in-wall flush box, Ø 55 mm, base with 4-hole for mounting on vertically or horizontally installed in-wall flush boxes for cable entry from the back, with predetermined breaking point for on-wall cable entry from top / bottom in case of plain on-wall installation
Protection class:	III (according to EN 60 730)
Protection type:	<b>IP 30</b> (according to EN 60 529)
Standards:	CE conformity, electromagnetic compatibility according to EN 61 326, EMC Directive 2014 / 30 / EU, Low Voltage Directive 2014 / 35 / EU
Optional:	<b>with traffic light indicator</b> (five coloured LEDs, see table) for displaying the air quality.



Dimensional drawing

RLQ-W  
RLQ-SD

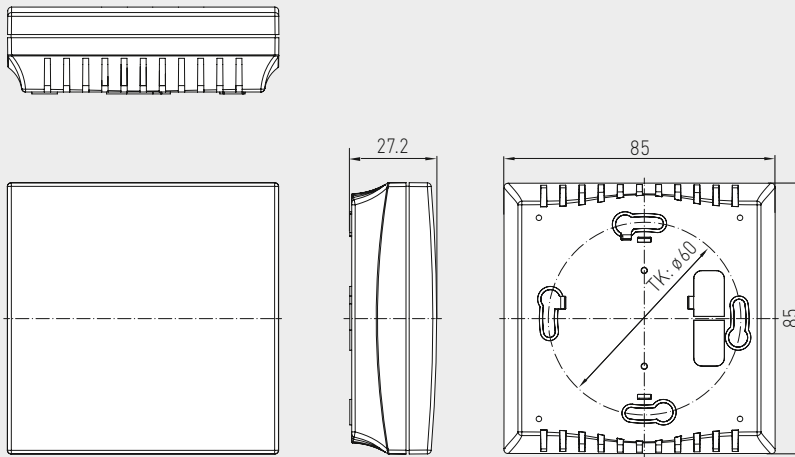

RLQ-W-A  
with LEDs



Dimensional drawing

RLQ-W VA

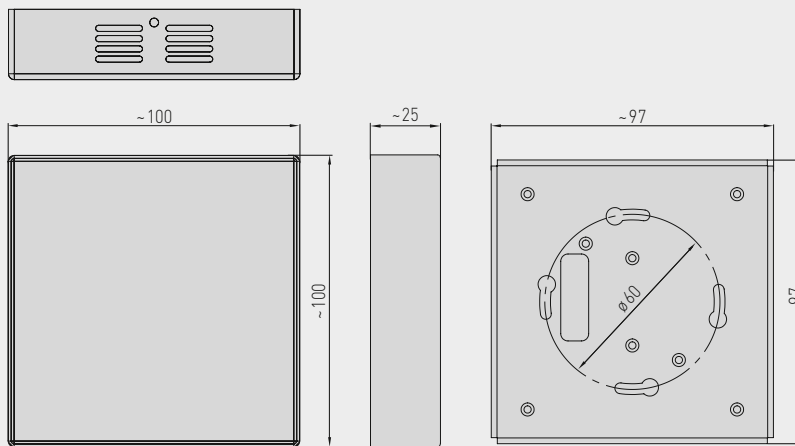

RLQ-W VA  
(stainless steel housing)



Room air quality sensor (VOC) and measuring transducer, self-calibrating, with multi-range switching and active/switching output

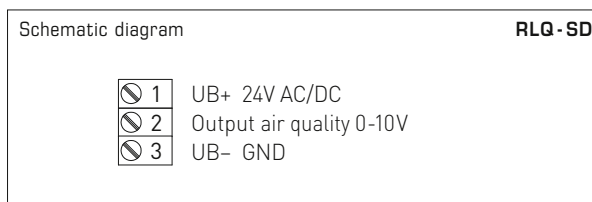
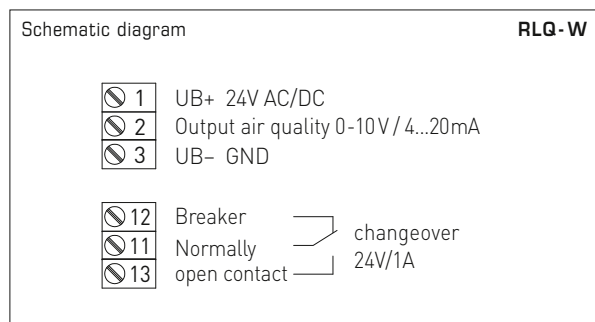
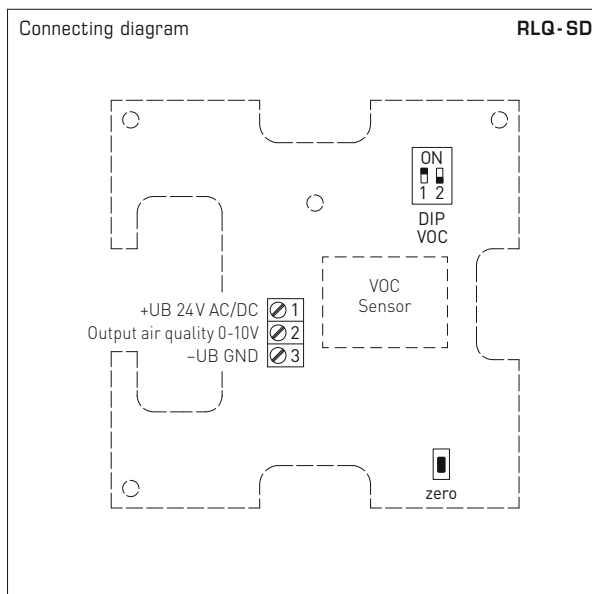
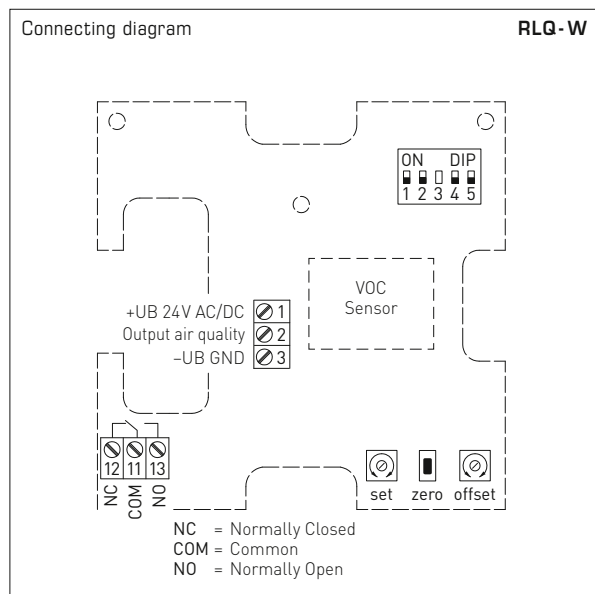

DIP switches RLQ-W		
VOC sensitivity	DIP 1	DIP 2
LOW	OFF	OFF
MEDIUM (default)	ON	OFF
HIGH	OFF	ON
IAQ (Indoor Air Quality)	ON	ON
Output	DIP 4	
Voltage 0-10V (default)	OFF	
Current 4...20mA	ON	
Traffic light (5x LEDs)	DIP 5	
deactivated	OFF	
activated	ON	
Note: DIP 3 is not assigned!		

DIP switches RLQ-SD		
VOC sensitivity	DIP 1	DIP 2
LOW	OFF	OFF
MEDIUM (default)	ON	OFF
HIGH	OFF	ON
IAQ (Indoor Air Quality)	ON	ON

Level	IAQ (Indoor Air Quality)	VOC
1	<b>excellent</b> no action required	0...19%
2	<b>good</b> prompt airing recommended	20...39%
3	<b>moderate</b> airing recommended	40...59%
4	<b>poor</b> increased airing required	60...79%
5	<b>unhealthy</b> intense airing necessary	80...100%

Table according to TVOC guidelines of the German Federal Environmental Agency to assess indoor air contamination (Bundesgesundheitsbl – Gesundheitsforsch – Gesundheitsschutz 2007, 50: 990-1005)



S+S REGELTECHNIK

AERASGARD® RLQ-W  
AERASGARD® RLQ-SD

Room air quality sensor (VOC) and measuring transducer,  
self-calibrating, with multi-range switching  
and active/switching output



Traffic light indicator					RLQ-W-A
VOC content	LED 1 green	LED 2 green	LED 3 yellow	LED 4 yellow	LED 5 red
0 %	25 %	-	-	-	-
5 %	50 %	-	-	-	-
10 %	75 %	-	-	-	-
15 %	100 %	-	-	-	-
20 %		25 %	-	-	-
25 %		50 %	-	-	-
30 %		75 %	-	-	-
35 %		100 %	-	-	-
40 %			25 %	-	-
45 %			50 %	-	-
50 %			75 %	-	-
55 %			100 %	-	-
60 %				25 %	-
65 %				50 %	-
70 %				75 %	-
75 %				100 %	-
80 %					25 %
85 %					50 %
90 %					75 %
95 %					100 %
100 %					

Once the aforementioned values have been reached, the respective LED becomes active (with increasing luminosity of 25 %, 50 %, 75 % and 100 %); LEDs that are already active continue to be illuminated.

RLQ-W-A  
with LEDs



AERASGARD® RLQ-SD Room air quality sensor (VOC) and measuring transducer, *Standard*  
AERASGARD® RLQ-W Room air quality sensor (VOC) and measuring transducer, *Premium*

Type / WG02	Measuring Range VOC	Output VOC	Equipment	Item No.	Price
<b>RLQ-SD</b>		(fixed)			
RLQ-SD-U	0...100 %	0-10 V	-	1501-61C0-1001-500	<b>164,14 €</b>
<b>RLQ-W</b>		(switchable)			
RLQ-W	0...100 %	0-10 V / 4...20 mA	Changeover contact	1501-61C0-7301-500	<b>172,04 €</b>
RLQ-W VA	0...100 %	0-10 V / 4...20 mA	Changeover contact, stainless steel housing	1501-61C0-7301-505	<b>275,11 €</b>
<b>RLQ-W-A</b>		(switchable)		<b>with traffic light</b>	
RLQ-W-A	0...100 %	0-10 V / 4...20 mA	Changeover contact, LEDs	1501-61C0-7331-500	<b>196,29 €</b>

A = with "traffic light" (five coloured LEDs) for displaying the air quality (VOC).

Note: This unit **must not** be used as safety-relevant device!





**CO2 traffic light / mobile CO2 sensor,  
room CO2 sensor with traffic light indicator and acoustic signal,  
self-calibrating**

Maintenance-free room sensor **AERASGARD® RCO2-AS xx** with traffic-light indicator and acoustic signal, self-calibrating, in an attractive plastic housing, for determining the CO2 content of the room air (0...3000 ppm). The measuring transducer converts the measurand to a standard signal, which is directly presented visually via coloured LEDs (traffic light indicator). An additional signal tone sounds when the warning levels are reached (can be switched off via DIP switch).

Available as a table-top unit **RCO2-AS NT ST** with micro USB power cord and stainless steel stand holder, as well as the device versions **RCO2-AS NT** (with plug-in power supply unit), **RCO2-AS UPNT** (with in-wall power supply unit) and **RCO2-AS** (without power supply unit) for wall mounting.

The room filter with **CO2 traffic light** is used in classrooms, training rooms and convention centres, offices, hotels, apartments, shops, etc. and is used for easy and quick evaluation of the indoor climate. This enables energy-saving demand-based room ventilation, thereby reducing operating costs and improving well-being. One sensor for every 30m² of room area is recommended

The CO2 measurement is performed using an optical **NDIR sensor** (non-dispersive infra-red technology). You will find more information at the beginning of the chapter.

**RCO2-AS**  
without power supply unit



**RCO2-AS UPNT**  
with in-wall power supply unit



**TECHNICAL DATA**

Power supply:	<b>RCO2-AS:</b> 5...24 V DC <b>RCO2-AS UPNT:</b> 5...24 V DC / 230 V AC (power supply unit)* <b>RCO2-AS NT:</b> 5...24 V DC / 230 V AC (power supply unit)* <b>RCO2-AS NT ST:</b> 5 V DC / 230 V AC (power supply unit)* *(included in the scope of delivery)
electrical connection:	<b>RCO2-AS:</b> terminal screws on circuit board (0.14 - 1.5 mm²), without power supply unit <b>RCO2-AS UPNT:</b> terminal screws on circuit board (0.14 - 1.5 mm²), in-wall power supply unit (open cable ends) <b>RCO2-AS NT:</b> terminal screws on circuit board (0.14 - 1.5 mm²), plug-in power supply unit (open cable ends/Euro plug) <b>RCO2-AS NT ST:</b> Micro-USB socket on circuit board, Micro-USB power supply (micro-USB/Euro plug)
Connection type:	2-wire circuit (no reverse polarity protection!)
Sensor:	optical NDIR sensor (non-dispersive infrared technology), with manual calibration (via zero button) with automatic calibration
Measurement range:	0...3000 ppm
Measuring accuracy:	typically ±30 ppm ±3% of measured value
Temperature dependence:	±5 ppm / °C or ±0.5% of measured value / °C (whichever is greater)
Pressure dependence:	±0.13% / mm Hg
Long-term stability:	<2% in 15 years
Gas exchange:	by diffusion
Ambient temperature:	0...+50 °C
Warm-up time:	approx. 1 hour
Measuring interval:	< 3 seconds
Housing:	plastic, material ABS, colour: pure white (similar to RAL 9010)
Dimensions:	85x85x27 mm (Baldur 1 housing) 110x85x100 mm (housing for stand holder)
Mounting:	<b>RCO2-AS NT ST:</b> immediately usable free-standing device without mounting (plug-and-play) <b>RCO2-AS, RCO2-AS NT, RCO2-AS UPNT:</b> wall mounting or on in-wall flush box, Ø 55 mm, base with 4 holes, for attachment to vertically or horizontally installed in-wall flush boxes for rear cable entry, with predetermined breaking point for top/bottom cable entry for surface-mounted installation
Protection class:	III (according to EN 60 730)
IP rating:	<b>IP 30</b> (according to EN 60 529)
Standards:	CE-conformity, electromagnetic compatibility according to EN 61 326, EMC directive 2014 / 30 / EU, low voltage directive 2014 / 35 / EU
Equipment:	<b>traffic light indicator</b> (five coloured LEDs), <b>acoustic signal</b> (signal can be switched off) for displaying the CO2 concentration Type-specific equipment (see table): <b>Plug-in power supply unit</b> (CL = approx. 1.5 m) <b>In-wall power supply unit</b> for mounting on in-wall flush boxes <b>Stand holder</b> made from stainless steel



**NEW**

S+S REGELTECHNIK

AERASGARD® **RCO2-AS xx**

CO2 traffic light/mobile CO2 sensor,  
room CO2 sensor with traffic light indicator and acoustic signal,  
self-calibrating

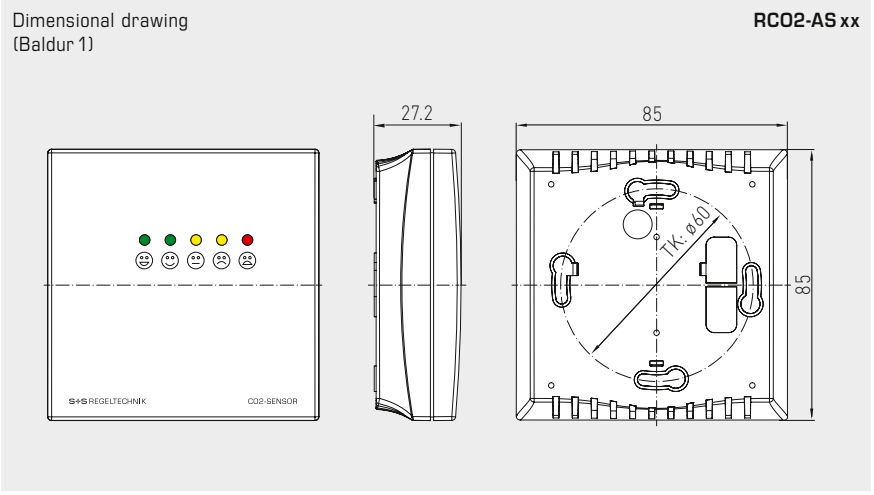

**RCO2-AS NT**  
with plug-in power supply unit

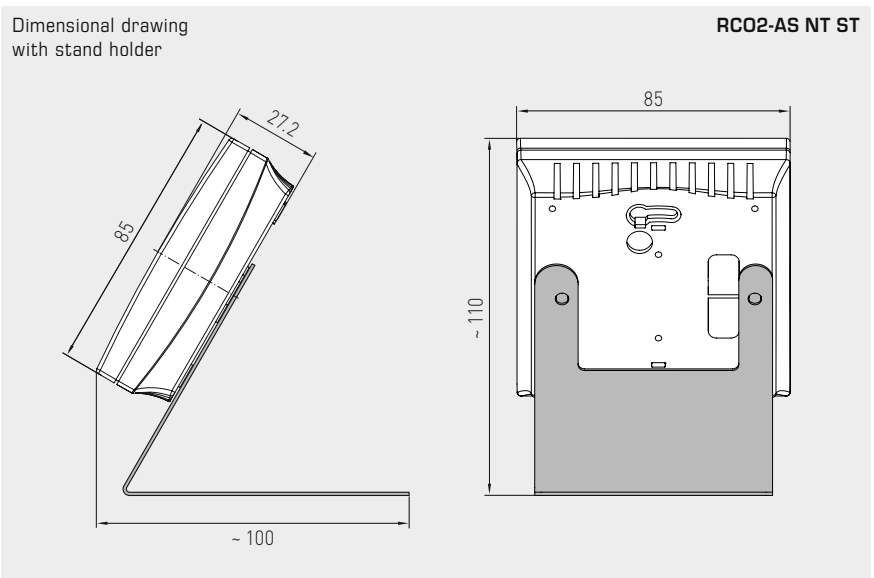

**RCO2-AS NT ST**  
with Micro-USB power supply unit  
and stainless steel  
stand holder



CO2 traffic light / mobile CO2 sensor,  
room CO2 sensor with traffic light indicator and acoustic signal,  
self-calibrating

Indicator	RCO2-AS xx					
CO2 content [ppm]	LED 1 green	LED 2 green	LED 3 yellow	LED 4 yellow	LED 5 red	signal tone
< 400	20 %	-	-	-	-	
401 - 500	40 %	-	-	-	-	
501 - 600	60 %	-	-	-	-	
601 - 700	80 %	-	-	-	-	
<b>701 - 800</b>	<b>100 %</b>	-	-	-	-	
801 - 840		20 %	-	-	-	
841 - 880		40 %	-	-	-	
881 - 920		60 %	-	-	-	
921 - 960		80 %	-	-	-	
<b>961 - 1000</b>		<b>100 %</b>	-	-	-	
1001 - 1080			20 %	-	-	1x 0.5 s
1081 - 1160			40 %	-	-	
1161 - 1240			60 %	-	-	
1241 - 1320			80 %	-	-	
<b>1321 - 1400</b>			<b>100 %</b>	-	-	
1401 - 1520				20 %	-	2x 0.5 s
1521 - 1640				40 %	-	
1641 - 1760				60 %	-	
1761 - 1880				80 %	-	
<b>1881 - 2000</b>				<b>100 %</b>	-	
2001 - 2200					20 %	3x 0.5 s
2201 - 2400					40 %	
2401 - 2600					60 %	
2601 - 2800					80 %	
<b>2801 - 3000</b>					<b>100 %</b>	1x 1.5 s

Recommendation	RCO2-AS xx	
Level	Traffic light indicator	signal tone (0.5 sec)
1	<b>green</b> no action required	
2	<b>green</b> prompt airing recommended	
3	<b>yellow</b> airing recommended	🔊
4	<b>yellow</b> airing required	🔊🔊
5	<b>red</b> intensive airing necessary	🔊🔊🔊

Once the aforementioned values have been reached, the respective LED becomes active (with increasing luminosity of 20 %, 40 %, 60 %, 80 % and 100 %); LEDs that are already active continue to be illuminated.

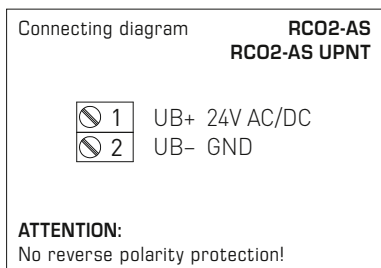
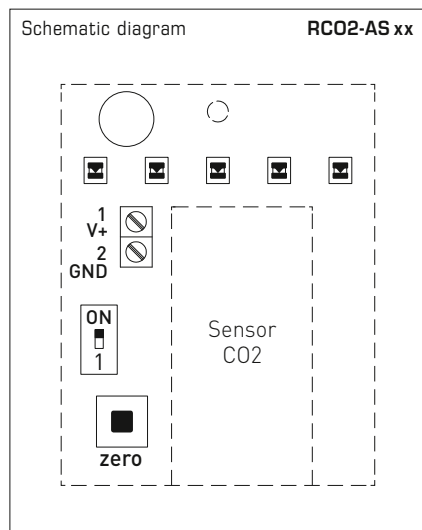

DIP switches	RCO2-AS xx
Acoustic signal (can be switched off)	DIP 1
active signal tone On (default)	ON
deactivated signal tone Off	OFF





**NEW**

CO2 traffic light/mobile CO2 sensor,  
room CO2 sensor with traffic light indicator and acoustic signal,  
self-calibrating

**RCO2-AS**  
without power supply unit



**RCO2-AS UPNT**  
with in-wall power supply unit



**RCO2-AS NT**  
with plug-in power supply unit



**RCO2-AS NT ST**  
with Micro-USB power supply unit  
and stainless steel  
stand holder



AERASGARD® RCO2-AS xx		Room CO2 sensor with traffic light display and acoustic signal			
Type/WG02	Measuring ranges CO2	Display CO2	Equipment	Item no. (Balduz 1)	Price
<b>RCO2-AS xx</b>					
RCO2-AS	0...3000 ppm	5 LEDs, signal tone	without power supply unit	1501-61A0-0686-230	<b>192,12 €</b>
RCO2-AS NT	0...3000 ppm	5 LEDs, signal tone	Plug-in power supply unit	1501-61A0-0686-232	<b>196,23 €</b>
RCO2-AS NT ST	0...3000 ppm	5 LEDs, signal tone	Micro-USB power supply unit, stainless steel stand holder	1501-61A0-0686-231	<b>193,19 €</b>
RCO2-AS UPNT	0...3000 ppm	5 LEDs, signal tone	In-wall power supply unit	1501-61A0-0686-233	<b>286,42 €</b>
Note:	This unit must <b>not</b> be used as a safety-relevant device!				



**Room CO2 sensor and measuring transducer,  
self-calibrating, with multi-range switching  
and active/switching output**

Maintenance-free room sensor **AERASGARD® RCO2 - SD** with active output, automatic calibration (fixed), in an elegant plastic housing with snap-on lid, for determining the CO2 content of the air (0...2000ppm). The measuring transducer converts the measured values into a standard signal of 0-10V.

Maintenance-free room sensor **AERASGARD® RCO2 - W** with active/switching output, automatic calibration (can be deactivated), in an elegant plastic housing with snap-on lid, optional with traffic light indicator (five coloured LEDs), for determining the CO2 content of the air (0...2000 ppm/0...5000 ppm). The measuring transducer converts the measured values into a standard signal of 0-10V or 4...20mA (switchable).

The sensor is used in offices, hotels, convention centres, apartments, shops, etc. for the purpose of evaluating the indoor climate. This enables energy-saving room ventilation on an as-needed basis, thereby reducing operating costs and improving well-being. One sensor for every 30m<sup>2</sup> of room area is recommended.

The CO2 measurement is performed using an optical **NDIR sensor** (non-dispersive infra-red technology). The detection range is calibrated for standard applications such as monitoring residential rooms and conference rooms.

For more information, see the start of the chapter.

### TECHNICAL DATA

Power supply:	24 V AC / DC (± 10 %)
Power consumption:	< 1.5 W / 24 V DC typical; < 2.9 VA / 24 V AC typical; peak current 200 mA
Sensor:	Optical NDIR sensor (non-dispersive infra-red technology), with manual calibration (via zero button), <b>RCO2 - SD</b> with automatic calibration (fixed) <b>RCO2 - W</b> with automatic calibration (can be deactivated via DIP switches)
Measuring range:	<b>RCO2 - SD</b> 0...2000 ppm (fixed) <b>RCO2 - W</b> 0...2000 ppm or 0...5000 ppm (selectable via DIP switches)
Output:	<b>RCO2 - SD</b> 0-10 V (fixed) <b>RCO2 - W</b> 0-10 V or 4...20 mA, working resistance < 800 Ω (selectable via DIP switches), with offset potentiometer (± 10 % of the measuring range)
Relay output:	<b>RCO2 - SD</b> without changeover contact <b>RCO2 - W</b> with potential-free <b>changeover contact</b> (24 V / 1 A)
Measuring accuracy:	typically ± 30 ppm ± 3 % of measured value
Temperature dependence:	± 5 ppm / °C or ± 0.5 % of measured value / °C (whichever is higher)
Pressure dependence:	± 0.13 % / mm Hg
Long-term stability:	< 2 % in 15 years
Gas exchange:	by diffusion
Ambient temperature:	0...+ 50 °C
Warm up time:	approx. 1 hour
Response time:	< 2 minutes
Electrical connection:	0.14 - 1.5 mm <sup>2</sup> , via screw terminals
Housing:	plastic, material ABS, colour pure white (similar to RAL 9010), stainless steel housing optional <b>V2A</b> (1.4301)
Dimensions:	85 x 85 x 27 mm (Baldur 1) 100 x 100 x 25 mm (stainless steel)
Installation:	wall mounting or on in-wall flush box, Ø 55 mm, base with 4-hole for mounting on vertically or horizontally installed in-wall flush boxes for cable entry from the back, with predetermined breaking point for on-wall cable entry from top / bottom in case of plain on-wall installation
Protection class:	III (according to EN 60 730)
Protection type:	<b>IP 30</b> (according to EN 60 529)
Standards:	CE conformity, electromagnetic compatibility according to EN 61 326, EMC Directive 2014 / 30 / EU, Low Voltage Directive 2014 / 35 / EU
Optional:	<b>with traffic light indicator</b> (five coloured LEDs, see table) for displaying the CO2 concentration  <b>with display</b> (see <b>AERASGARD® RFTM-LQ-CO2</b> ) for displaying the actual CO2 content in ppm





Dimensional drawing

RC02-W  
RC02-SD

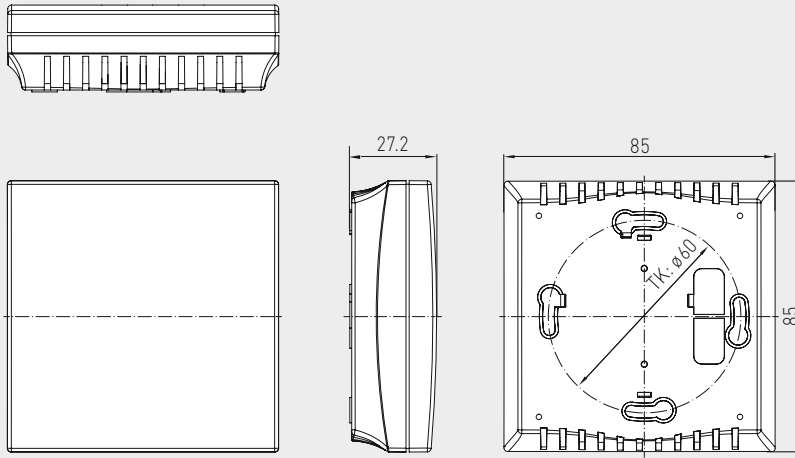

RC02-W  
RC02-SD



Dimensional drawing

RC02-W VA

RC02-W VA  
(stainless steel housing)

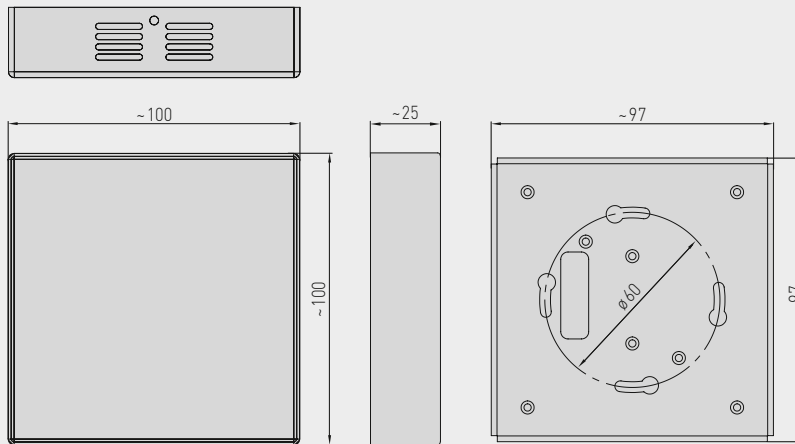

Room CO2 sensor and measuring transducer,  
 self-calibrating, with multi-range switching  
 and active/switching output

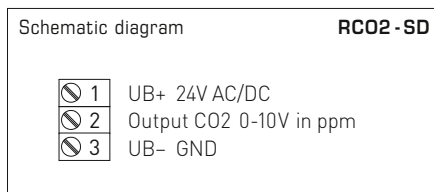
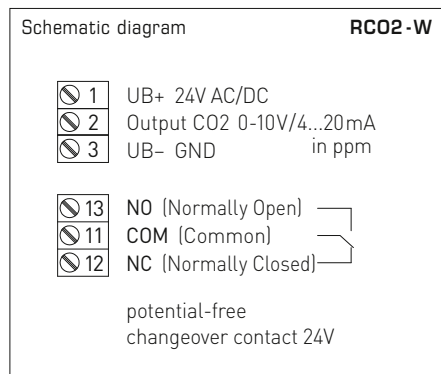
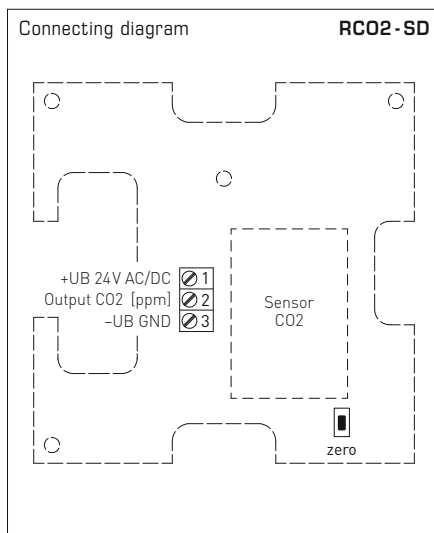
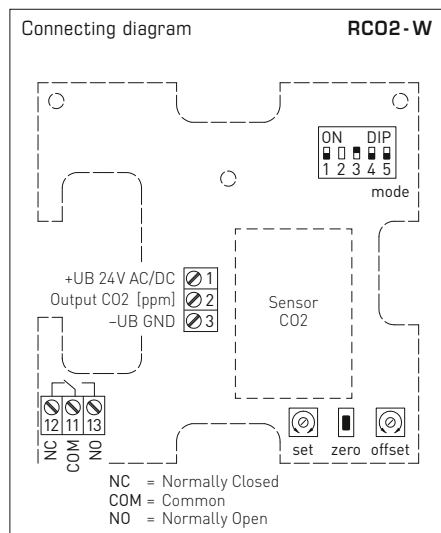

DIP switches RCO2-W	
<b>CO2 content</b>	<b>DIP 1</b>
0...2000 ppm (default)	OFF
0...5000 ppm	ON
<b>CO2 automatic zero point</b>	<b>DIP 3</b>
deactivated	OFF
activated (default)	ON
<b>Output</b>	<b>DIP 4</b>
Voltage 0-10V (default)	OFF
Current 4...20mA	ON
<b>Traffic light (5x LEDs)</b>	<b>DIP 5</b>
deactivated	OFF
activated	ON
Note: DIP 2 is not assigned!	



Traffic light indicator		RC02-W-A				
CO2 content in ppm		LED 1	LED 2	LED 3	LED 4	LED 5
0...2000 ppm	0...5000 ppm	green	green	yellow	yellow	red
350	350	20%	-	-	-	-
416	536	40%	-	-	-	-
482	722	60%	-	-	-	-
548	908	80%	-	-	-	-
<b>614</b>	<b>1094</b>	<b>100%</b>	-	-	-	-
680	1280		20%	-	-	-
746	1466		40%	-	-	-
812	1652		60%	-	-	-
878	1838		80%	-	-	-
<b>944</b>	<b>2024</b>		<b>100%</b>	-	-	-
1010	2210			20%	-	-
1076	2396			40%	-	-
1142	2582			60%	-	-
1208	2768			80%	-	-
<b>1274</b>	<b>2954</b>			<b>100%</b>	-	-
1340	3140				20%	-
1406	3326				40%	-
1472	3512				60%	-
1538	3698				80%	-
<b>1604</b>	<b>3884</b>				<b>100%</b>	-
1670	4070					20%
1736	4256					40%
1802	4442					60%
1868	4628					80%
<b>1934</b>	<b>4814</b>					<b>100%</b>
2000	5000					

Once the aforementioned values have been reached, the respective LED becomes active (with increasing luminosity of 20%, 40%, 60%, 80% and 100%); LEDs that are already active continue to be illuminated.



RC02-W-A  
with LEDs



AERASGARD® RC02-SD Room CO2 sensor and measuring transducer, *Standard*  
AERASGARD® RC02-W Room CO2 sensor and measuring transducer, *Premium*

Type / WG02	Measuring Range CO2	Output CO2	Equipment	Display	Item No. (Baldur 1)	Price
<b>RC02-SD</b>	(fixed)	(fixed)				
RC02-SD-U	0...2000 ppm	0-10 V	-		1501-61A0-1001-200	<b>199,72 €</b>
<b>RC02-W</b>	(switchable)	(switchable)				
RC02-W	0...2000 ppm / 0...5000 ppm	0-10 V / 4...20 mA	Changeover contact		1501-61A0-7301-200	<b>236,61 €</b>
RC02-W VA	0...2000 ppm / 0...5000 ppm	0-10 V / 4...20 mA	Changeover contact, stainless steel housing		1501-61A0-7301-205	<b>338,16 €</b>
RC02-W LCD	0...2000 ppm / 0...5000 ppm	0-10 V / 4...20 mA	Changeover contact, display	■ see RFTM-LQ-CO2		
<b>RC02-W-A</b>	(switchable)	(switchable)			<b>with traffic light</b>	
RC02-W-A	0...2000 ppm / 0...5000 ppm	0-10 V / 4...20 mA	Changeover contact, LEDs		1501-61A0-7331-200	<b>278,07 €</b>

A = with "traffic light" (five coloured LEDs) for displaying the CO2 concentration.

Note: This unit **must not** be used as safety-relevant device!



**Multifunctional room sensors and measuring transducers,  
 for humidity, temperature, air quality (VOC) and CO2 content,  
 calibratable, with active/switching output**

Maintenance-free room sensor **AERASGARD® RTM - CO2 - SD** with active output, automatic calibration, in an elegant plastic housing with snap-on lid, for determining the CO2 content of the air (0...2000 ppm) and the temperature (0...+50°C). The measuring transducer converts the measured values into a standard signal of 0-10V.

Maintenance-free room sensor **AERASGARD® RFTM - LQ - CO2 - W** with active/switching output, automatic calibration, in an elegant plastic housing with snap-on lid, optionally with/without display, for determining the CO2 content of the air (0...2000 ppm/0...5000 ppm), the quality in three VOC sensitivity (0...100% VOC), the temperature (0...+50°C) as well as the relative air humidity (0...100% r.H.). The measuring transducer converts the measured values into a standard signal of 0-10V or 4...20 mA (switchable).

The sensor is used in offices, hotels, convention centres, apartments, shops, etc. for the purpose of evaluating the indoor climate. This enables energy-saving room ventilation on an as-needed basis, thereby reducing operating costs and improving well-being. One sensor for every 30 m² of room area is recommended.

A long-term stable, **digital humidity and temperature sensor** guarantees exact measurement results.

The CO2 measurement is performed using an optical **NDIR sensor** (non-dispersive infra-red technology).

The detection range is calibrated for standard applications such as monitoring residential rooms and conference rooms.

The air quality is detected by a **VOC sensor** (mixed gas sensor for volatile organic substances). This sensor determines the loading of the room air due to contaminated gases such as cigarette smoke, body perspiration, exhaled breathing air, solvent vapours, emissions, etc. As an alternative, use IAQ categories (from excellent to unhealthy) following the guidelines of the German Federal Environmental Agency to assess the room air.

For more information, see the start of the chapter.

### TECHNICAL DATA

Voltage supply:	24 V AC / DC (± 10 %)
Power consumption:	<b>RCO2 - W / RTM - CO2 - SD:</b> < 1.5 W / 24 V DC typical; < 2.9 VA / 24 V AC typical; peak current 200 mA <b>RLQ - CO2 - W / RFTM - LQ - CO2 - W:</b> < 4.4 W / 24 V DC typical; < 6.4 VA / 24 V AC typical; peak current 200 mA
Outputs:	<b>RTM - CO2 - SD</b> 0-10V (fixed) <b>Rxx - CO2 - W</b> 0-10V or 4...20 mA, working resistance < 800 Ω (selectable via DIP switches, selected variant applies for all outputs), with offset potentiometer (± 10 % of the measuring range)
Relay output:	<b>RTM - CO2 - SD</b> without changeover contact <b>Rxx - CO2 - W</b> with potential-free <b>changeover contact</b> (24 V / 1 A) (assignment selectable via DIP switches, switchpoint adjustable)

### HUMIDITY

Sensor (RH / °C):	<b>digital humidity sensor with integrated temperature sensor,</b> low hysteresis, high long-term stability
Measuring range (RH):	0...100% r. H.
Output (RH):	0-10 V or 4...20 mA (selectable via DIP switches)
Deviation (RH):	typically <b>± 2.0 %</b> (20...80% r. H.) bei +25 °C, sonst ± 3.0 %

### TEMPERATURE

Measuring range (°C):	0...+ 50 °C
Deviation (°C):	typically ± 0.2 K bei +25 °C
Output (°C):	<b>RTM - CO2 - SD</b> 0-10 V (fixed) <b>Rxx - CO2 - W</b> 0-10 V or 4...20 mA (selectable via DIP switches)

### AIR QUALITY (VOC)

Sensor (VOC):	VOC sensor (metal oxide) (VOC = volatile organic compounds), with manual calibration (via zero button) and automatic calibration (permanently active)
Measuring range (VOC):	0...100% air quality; referred to calibrating gas; <b>multi-range switching</b> (selectable via DIP switches) VOC sensitivities (low/medium/high) or IAQ category (Indoor Air Quality)
Output (VOC):	0-10 V (0V = clean air, 10 V = polluted air) or 4...20 mA (selectable via DIP switches, switchpoint can be adjusted from 0...100% of the output signal)
Measuring accuracy (VOC):	typically <b>± 20 %</b> of final value (referred to calibrating gas)
Service life (VOC):	> 60 months (under normal load conditions) depending on the type of loading and gas concentration

### CARBON DIOXIDE (CO2)

Sensor (CO2):	optical NDIR sensor (non-dispersive infra-red technology), with manual calibration (via zero button), <b>RTM - CO2 - SD</b> with automatic calibration (fixed) <b>Rxx - CO2 - W</b> with automatic calibration (can be deactivated via DIP switches)
Measuring range (CO2):	<b>RTM - CO2 - SD</b> 0...2000 ppm (fixed) <b>Rxx - CO2 - W</b> 0...2000 ppm or 0...5000 ppm (selectable via DIP switches)
Output (CO2):	<b>RTM - CO2 - SD</b> 0-10 V (fixed) <b>Rxx - CO2 - W</b> 0-10 V or 4...20 mA (selectable via DIP switches)
Measuring accuracy (CO2):	typically <b>± 30 ppm</b> (± 3% of measured value)
Temperature dependence (CO2):	± 5 ppm / °C or ± 0.5% of measured value / °C (whichever is higher)
Pressure dependence (CO2):	± 0.13 % / mm Hg
Long-term stability (CO2):	< 2 % in 15 years
Gas exchange (CO2):	by diffusion

continued on next page!



S+S REGELTECHNIK

# AERASGARD® RC02 - W / RLQ - CO2 - W AERASGARD® RFTM - (LQ) - CO2 - W / RTM - CO2 - SD

Multifunctional room sensors and measuring transducers,  
for humidity, temperature, air quality (VOC) and CO2 content,  
calibratable, with active/switching output



Dimensional drawing

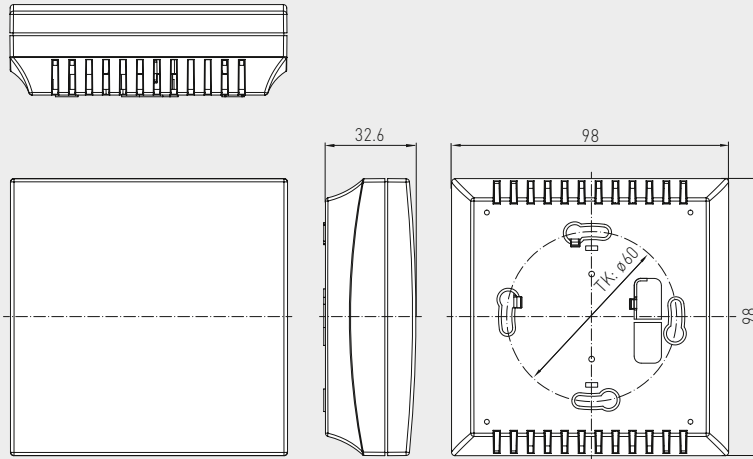

RC02 - W with display  
RLQ - CO2 - W  
RFTM - LQ - CO2 - W  
RTM - CO2 - SD

RLQ - CO2 - W  
RFTM - LQ - CO2 - W  
RTM - CO2 - SD



Dimensional drawing

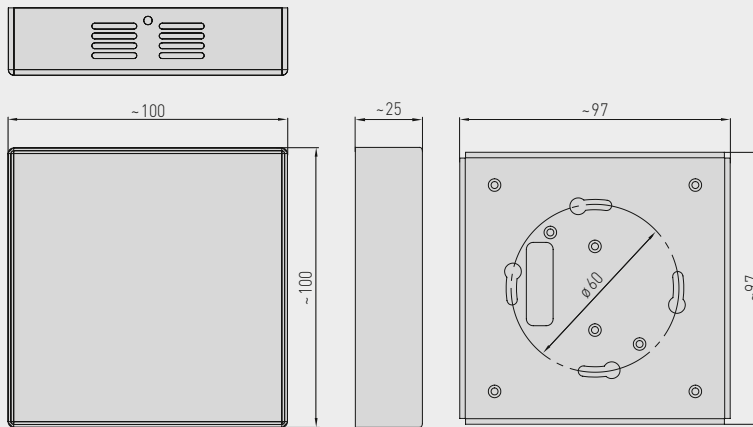

Stainless steel housing  
(See picture  
on next page)

RC02 - W  
RLQ - CO2 - W  
RFTM - LQ - CO2 - W  
with display



## TECHNICAL DATA

[continued]

Ambient temperature:	0...+50 °C
Permitted humidity:	0...95% r. H. (non-precipitating air)
Warm up time:	approx. 1 hour
Response time:	< 2 minutes
Electrical connection:	0.14 - 1.5 mm <sup>2</sup> , via screw terminals
Housing:	plastic, material ABS, colour pure white (similar to RAL 9010), stainless steel <b>V2A</b> (1.4301) housing optional
Dimensions:	98 x 98 x 33 mm (Baldur 2)
Installation:	wall mounting or on in-wall flush box, Ø55 mm, base with 4 holes, for attachment to vertically or horizontally installed in-wall flush boxes for rear cable entry, with predetermined breaking point for cable entry from top/bottom in case of plain on-wall installation
Protection class:	III (according to EN 60 730)
Protection type:	<b>IP 30</b> (according to EN 60 529)
Standards:	CE conformity, electromagnetic compatibility according to EN 61 326, EMC Directive 2014 / 30 / EU, Low Voltage Directive 2014 / 35 / EU
Optional:	<b>display with illumination</b> , two line, cutout approx. 36 x 15 mm (W x H), for displaying actual humidity, actual temperature, air quality and the actual CO2 content



# AERASGARD® RC02 - W / RLQ - CO2 - W AERASGARD® RFTM - (LQ) - CO2 - W / RTM - CO2 - SD



S+S REGELTECHNIK

Multifunctional room sensors and measuring transducers,  
for humidity, temperature, air quality (VOC) and CO<sub>2</sub> content,  
calibratable, with active/switching output

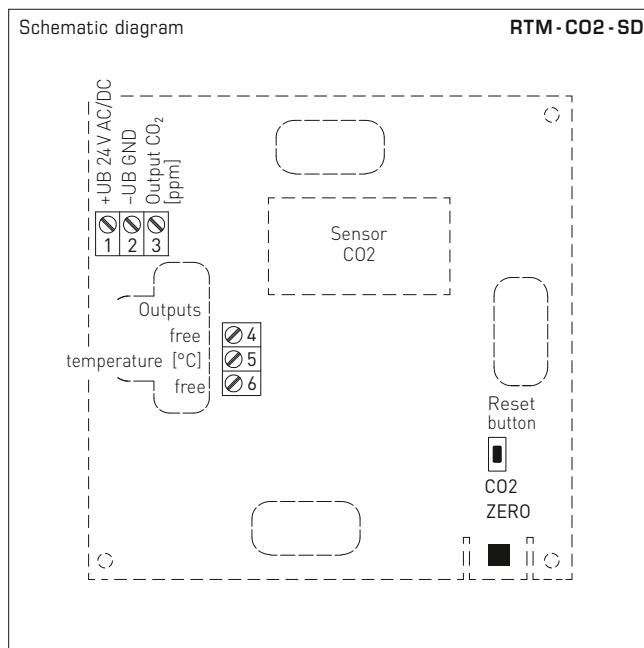
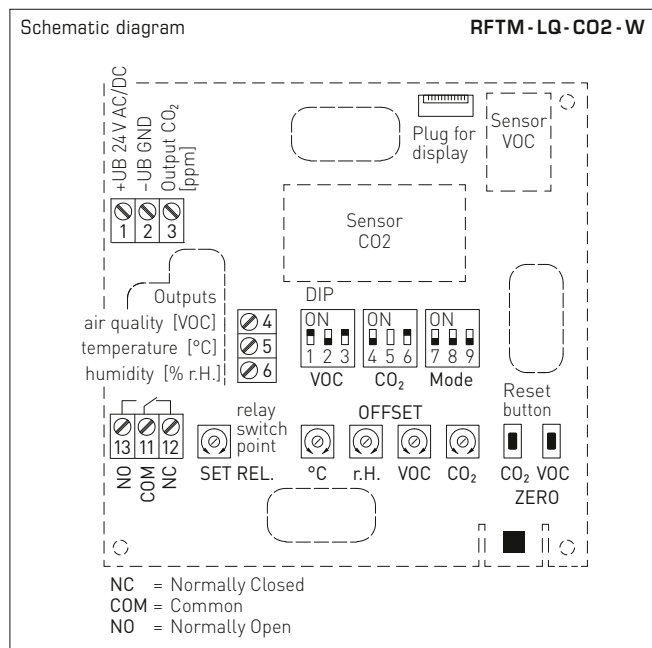

DIP switches (Baldur 2)		RFTM - LQ - CO2 - W	
<b>VOC sensitivity</b>		DIP 1	DIP 2
LOW		OFF	OFF
MEDIUM (default)		ON	OFF
HIGH		OFF	ON
<b>IAQ (Indoor Air Quality)</b>		ON	ON
<b>CO<sub>2</sub> content</b>			DIP 4
0...2000 ppm (default)			OFF
0...5000 ppm			ON
<b>CO<sub>2</sub> automatic zero point</b>			DIP 6
deactivated			OFF
activated (default)			ON
<b>Relay assignment</b>		DIP 7	DIP 8
CO <sub>2</sub> (default): 600...1900 ppm / 900...4700 ppm		OFF	OFF
VOC: 10...95%		ON	OFF
Temperature: +5...+48 °C		OFF	ON
Humidity: 10...95% r.H.		ON	ON
<b>Output</b>			DIP 9
Voltage 0-10V (default)			OFF
Current 4...20mA			ON
Note: DIP 3 and DIP 5 are not assigned!			

Level	IAQ (Indoor Air Quality)	VOC
1	<b>excellent</b> no action required	0...19%
2	<b>good</b> prompt airing recommended	20...39%
3	<b>moderate</b> airing recommended	40...59%
4	<b>poor</b> increased airing required	60...79%
5	<b>unhealthy</b> intense airing necessary	80...100%

Table according to TVOC guidelines of the German Federal Environmental Agency to assess indoor air contamination  
(Bundesgesundheitsbl - Gesundheitsforsch - Gesundheitsschutz 2007, 50: 990-1005)

RFTM - LQ - CO2 - W  
(Baldur 2)

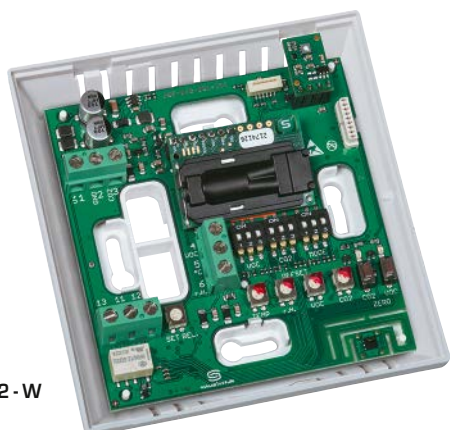

Stainless steel housing  
(optionally available upon request)





**Humidity table**

MR: 0...100% r.H.

% r.H.	U <sub>A</sub> in V	I <sub>A</sub> in mA
0	0	4.0
5	0.5	4.8
10	1.0	5.6
15	1.5	6.4
20	2.0	7.2
25	2.5	8.0
30	3.0	8.8
35	3.5	9.6
40	4.0	10.4
45	4.5	11.2
Continued at the right ...		

% r.H.	U <sub>A</sub> in V	I <sub>A</sub> in mA
50	5.0	12.0
55	5.5	12.8
60	6.0	13.6
65	6.5	14.4
70	7.0	15.2
75	7.5	16.0
80	8.0	16.8
85	8.5	17.6
90	9.0	18.4
95	9.5	19.2
100	10.0	20.0

**Temperature table**

MR: 0...+50 °C

°C	U <sub>A</sub> in V	I <sub>A</sub> in mA
0	0	4.0
5	1.0	5.6
10	2.0	7.2
15	3.0	8.8
20	4.0	10.4
25	5.0	12.0
30	6.0	13.6
35	7.0	15.2
40	8.0	16.8
45	9.0	18.4
50	10.0	20.0

AERASGARD® RTM-CO2-SD	Room temperature and CO2 sensor, <i>Standard</i>
AERASGARD® RCO2-W	Room CO2 sensor, <i>Premium</i>
AERASGARD® RLQ-CO2-W	Room air quality (VOC) and CO2 sensor, <i>Premium</i>
AERASGARD® RFTM-CO2-W	Multifunctional room sensor for humidity, temperature and CO2 content, <i>Deluxe</i>
AERASGARD® RFTM-LQ-CO2-W	Multifunctional room sensor for humidity, temperature, CO2 content and air quality (VOC), <i>Deluxe</i>

Type / WG02	Measuring Range				Equipment	Item No.	Price
	Humidity	Temperature	CO2	VOC	Display	(BalduR 2)	
<b>RTM-CO2-SD</b>			(fixed)				
RTM-CO2-SD-U	-	0...+50 °C	0...2000 ppm	-	-	1501-61B2-1001-200	<b>218,67 €</b>
<b>RCO2-W</b>			(switchable)				
RCO2-W (without display)	-	-	0...2000 / 5000 ppm	-	W	see <b>RCO2-W / RCO2-SD</b>	
RCO2-W LCD	-	-	0...2000 / 5000 ppm	-	W ■	1501-61B0-7321-200	<b>284,06 €</b>
<b>RLQ-CO2-W</b>			(switchable)				
RLQ-CO2-W	-	-	0...2000 / 5000 ppm	0...100%	W	1501-61B1-7301-500	<b>357,53 €</b>
RLQ-CO2-W LCD	-	-	0...2000 / 5000 ppm	0...100%	W ■	1501-61B1-7321-500	<b>404,99 €</b>
<b>RFTM-CO2-W</b>			(switchable)				
RFTM-CO2-W	0...100% r.H.	0...+50 °C	0...2000 / 5000 ppm	-	W	1501-61B6-7301-200	<b>334,00 €</b>
RFTM-CO2-W LCD	0...100% r.H.	0...+50 °C	0...2000 / 5000 ppm	-	W ■	1501-61B6-7321-200	<b>370,45 €</b>
<b>RFTM-LQ-CO2-W</b>			(switchable)				
RFTM-LQ-CO2-W	0...100% r.H.	0...+50 °C	0...2000 / 5000 ppm	0...100%	W	1501-61B8-7301-500	<b>392,09 €</b>
RFTM-LQ-CO2-W LCD	0...100% r.H.	0...+50 °C	0...2000 / 5000 ppm	0...100%	W ■	1501-61B8-7321-500	<b>439,54 €</b>
Outputs:	0-10V or 4...20 mA (selectable via DIP switches, selected variant applies for all outputs) – Standard room sensor <b>RTM-CO2-SD</b> with fixed output 0-10 V!						
Equipment:	W = changeover contact – Standard room sensor <b>RTM-CO2-SD</b> without changeover contact!						
Note:	This unit <b>must not</b> be used as safety-relevant device!						

# AERASGARD® RPS-SD AERASGARD® RFTM-PS-CO2-W

Fine dust sensor / particulate sensor,  
multifunctional room sensor and measuring transducer  
for humidity, temperature, fine dust (PM) and CO2 content,  
calibratable, with active/switching output

**NEW**



S+S REGELTECHNIK

Maintenance-free room sensor **AERASGARD® RPS-SD** with active output, in an elegant plastic housing with snap-on lid, base with 4-hole attachment, for detecting the fine dust content (0...500 µg/m³). The measuring transducer converts the measurand into a standard signal of 0-10V (fixed).

Maintenance-free, multifunctional room sensor **AERASGARD® RFTM-PS-CO2-W** with active/switching output, automatic calibration, in an elegant plastic housing with snap-on lid, base with 4-hole attachment, optionally with/without display, for detection of measurands air humidity (0...100% r.H.), temperature (0...+50°C), fine dust (PM) (0...50/100/300/500 µg/m³) and CO2 content (0...2000/5000 ppm). The measuring transducer converts the measurand into a standard signal of 0-10V or 4...20 mA (switchable).

Use just one device to monitor and control the entire indoor climate effectively. This enables energy-saving room ventilation on an as-needed basis, thereby reducing operating costs and improving well-being. It is used in offices, hotels, convention centres, apartments, shops, etc. One sensor for every 30 m² of room area is recommended.

A long-term stable, **digital humidity and temperature sensor** guarantees exact measurement results. The CO2 content of the air is measured using an optical **NDIR sensor** (non-dispersive infra-red technology). An optical **fine dust sensor** precisely detects **particulate (PM)** of the size category 0.3 to 10 micrometres. The sensor is factory-calibrated; an environmental precision adjustment by an expert is possible (except for particulate sensor).

## TECHNICAL DATA

Power supply:	24 V AC / DC (± 10 %)	
Power consumption:	<b>RPS-SD</b>	typically < 1.5 W / 24 V DC; < 2.9 VA / 24 V AC
	<b>RFTM-PS-CO2-W</b>	typically < 4.4 W / 24 V DC; < 6.4 VA / 24 V AC; peak current 200 mA
Output:	<b>RPS-SD</b>	0-10 V (fixed)
	<b>RFTM-PS-CO2-W</b>	0-10 V or 4...20 mA, working resistance < 800 Ω (selectable via DIP switches, selected version applies <b>uniformly</b> to all outputs, with offset potentiometer (± 10% of measuring range)
Relay output:	<b>RPS-SD</b>	without changeover contact
	<b>RFTM-PS-CO2-W</b>	with potential-free <b>changeover contact</b> (24 V / 1 A) (assignment selectable via DIP switches, switch point can be set)

## HUMIDITY

Sensor (RH / °C):	<b>digital humidity sensor with integrated temperature sensor</b> , low hysteresis, high long-term stability	
Measuring range (RH):	0...100% r. H.	
Output (RH):	0-10 V or 4...20 mA (selectable via DIP switches)	
Deviation (RH):	typically <b>± 2.0%</b> (20...80% r. H.) at +25 °C, otherwise ± 3.0%	

## TEMPERATURE

Measuring range (°C):	0...+ 50 °C	
Output (°C):	0-10 V or 4...20 mA (selectable via DIP switches)	
Deviation (°C):	typically ± 0.2 K at +25 °C	

## FINE DUST (PM)

Sensor (PM):	optical <b>particulate sensor (PM = particulate matter)</b> , <b>fine-dust sensor</b> with laser- and soiling-resistant technology	
Measuring range (PM):	multi-range switching (selectable via DIP switches) 0...50, 0...100, 0...300 or 0...500 µg/m³	
Output (PM):	<b>RPS-SD</b>	0-10 V (fixed)
	<b>RFTM-PS-CO2-W</b>	0-10 V or 4...20 mA (selectable via DIP switches)
Particle size (PM):	<b>PM 2.5</b> (0.3...2.5 µm); <b>PM 10</b> (0.3...10 µm)	
Measuring accuracy (PM):	typically ± 10 µg/m³ (± 10% of measured value) at PM 2.5 typically ± 25 µg/m³ (± 25% of measured value) at PM 10	
Long-term stability (PM):	± 1.25 µg/m³ (± 1.25% of measured value/year)	
Service life (PM):	> 10 years	

## CARBON DIOXIDE (CO2)

Sensor (CO2):	Optical <b>NDIR sensor</b> (non-dispersive infra-red technology), with manual calibration (via zero button), with automatic calibration (can be deactivated via DIP switches)	
Measuring range (CO2):	0...2000 ppm or 0...5000 ppm (selectable via DIP switches)	
Output (CO2):	0-10 V or 4...20 mA (selectable via DIP switches)	
Measuring accuracy (CO2):	typically ± 30 ppm (± 3% of measured value)	
Temperature dependence (CO2):	± 5 ppm / °C or ± 0.5% of measured value / °C (whichever is greater)	
Pressure dependence (CO2):	± 0.13% / mm Hg	
Long-term stability (CO2):	< 2% in 15 years	
Gas exchange (CO2):	Diffusion	

Continued on next page!



**NEW**

S+S REGELTECHNIK

# AERASGARD® RPS-SD AERASGARD® RFTM-PS-CO2-W

Fine dust sensor/particulate sensor, multifunctional room sensor and measuring transducer for humidity, temperature, fine dust (PM) and CO2 content, calibratable, with active/switching output

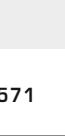
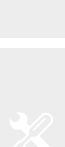

Dimensional drawing

RPS-SD  
RFTM-PS-CO2-W

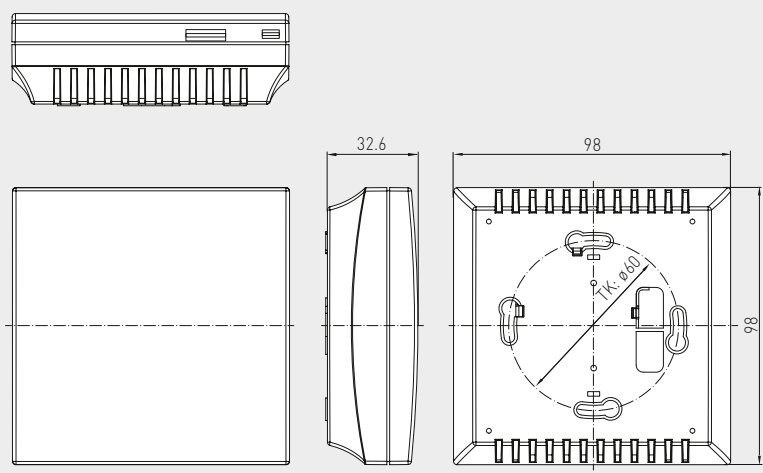

RPS-SD  
RFTM-PS-CO2-W  
without display



RFTM-PS-CO2-W  
with display



## TECHNICAL DATA [continued]

Ambient temperature:	0...+50 °C
Permitted humidity:	0...95% r. H. (non-precipitating air)
Warm up time:	approx. 1 hour
Response time:	< 2 minutes
Electrical connection:	0.14 - 1.5 mm <sup>2</sup> , via screw terminals
Housing:	plastic, material ABS, colour pure white (similar to RAL 9010)
Dimensions:	98 x 98 x 33 mm (BalduR2)
Mounting:	wall mounting or on in-wall flush box, Ø 55 mm, base with 4 holes, for attachment to vertically or horizontally installed in-wall flush boxes for rear cable entry, with predetermined breaking point for top/bottom cable entry for surface-mounted installation
Protection class:	III (according to EN 60730)
IP rating:	IP 30 (according to EN 60529)
Standards:	CE conformity, electromagnetic compatibility according to EN 61326, EMC Directive 2014/30/EU, Low Voltage Directive 2014/35/EU
Optional:	<b>Display with illumination</b> , 2-line, cutout approx. 36 x 15 mm (W x H), to display the actual humidity, actual temperature, of the fine-dust and CO2 content as well as for switch point display

# AERASGARD® RPS-SD AERASGARD® RFTM-PS-CO2-W

Fine dust sensor/particulate sensor,  
multifunctional room sensor and measuring transducer  
for humidity, temperature, fine dust (PM) and CO2 content,  
calibratable, with active/switching output

**NEW**



S+S REGELTECHNIK

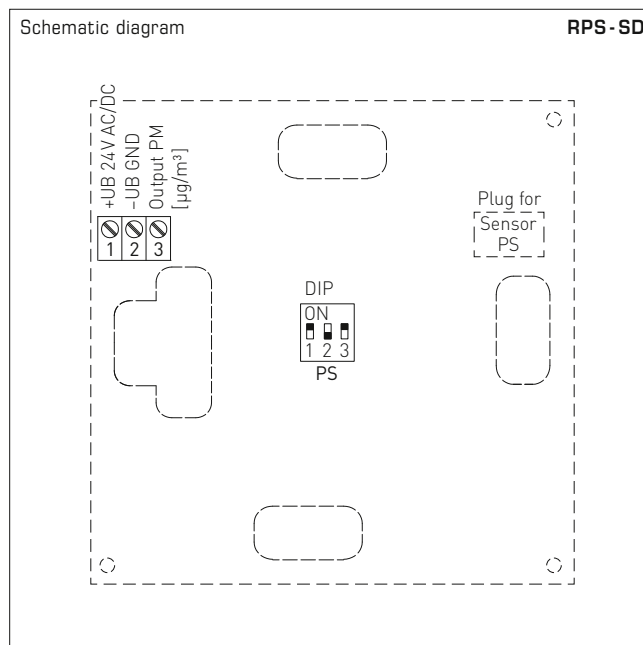
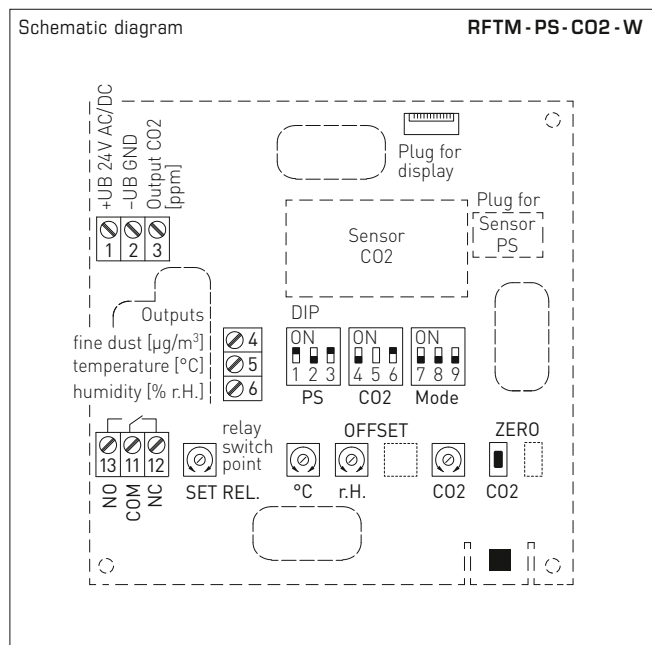

DIP switch	RFTM-PS-xx	
<b>Fine dust (PM) Measuring range</b>	DIP 1	DIP 2
0...50 $\mu\text{g}/\text{m}^3$	OFF	OFF
0...100 $\mu\text{g}/\text{m}^3$ (default)	ON	OFF
0...300 $\mu\text{g}/\text{m}^3$	OFF	ON
0...500 $\mu\text{g}/\text{m}^3$	ON	ON
<b>Fine dust (PM) Particle size</b>	DIP 3	
PM 2.5 (default)	ON	
PM 10	OFF	
<b>CO2 content</b>	DIP 4	
0...2000 ppm (default)	OFF	
0...5000 ppm	ON	
<b>CO2 automatic zero point</b>	DIP 6	
deactivated	OFF	
activated (default)	ON	
<b>Relay assignment</b>	DIP 7	DIP 8
CO2 (default) 600...1900 ppm / 900...4700 ppm	OFF	OFF
Fine dust 10%...95% of measuring range	ON	OFF
Temperature +5...+48 $^{\circ}\text{C}$	OFF	ON
Humidity 10...95% r.H.	ON	ON
<b>Output</b>	DIP 9	
Voltage 0-10V (default)	OFF	
Current 4...20mA	ON	
Note: DIP 5 is not assigned !		

DIP switch	RPS-SD	
<b>Fine dust (PM) Measuring range</b>	DIP 1	DIP 2
0...50 $\mu\text{g}/\text{m}^3$	OFF	OFF
0...100 $\mu\text{g}/\text{m}^3$ (default)	ON	OFF
0...300 $\mu\text{g}/\text{m}^3$	OFF	ON
0...500 $\mu\text{g}/\text{m}^3$	ON	ON
<b>Fine dust (PM) Particle size</b>	DIP 3	
PM 2.5 (default)	ON	
PM 10	OFF	

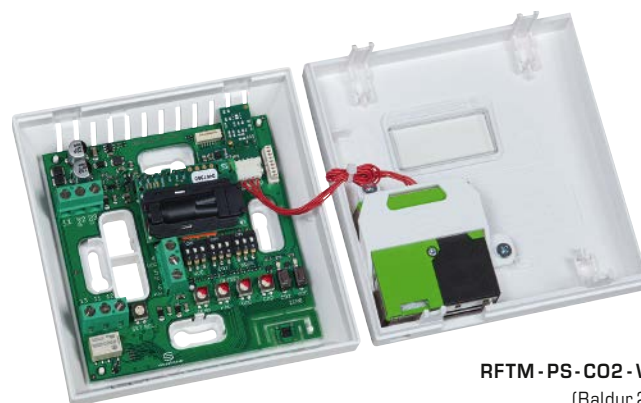

**RFTM-PS-CO2-W**  
(Baldur 2)





**NEW**

S+S REGELTECHNIK

**AERASGARD® RPS-SD**  
**AERASGARD® RFTM-PS-CO2-W**

Fine dust sensor/particulate sensor,  
multifunctional room sensor and measuring transducer  
for humidity, temperature, fine dust (PM) and CO2 content,  
calibratable, with active/switching output

**Humidity table**

MR: 0...100% r.H.

% r.H.	U <sub>A</sub> in V	I <sub>A</sub> in mA
0	0	4.0
5	0.5	4.8
10	1.0	5.6
15	1.5	6.4
20	2.0	7.2
25	2.5	8.0
30	3.0	8.8
35	3.5	9.6
40	4.0	10.4
45	4.5	11.2
Continued at the right ...		

% r.H.	U <sub>A</sub> in V	I <sub>A</sub> in mA
50	5.0	12.0
55	5.5	12.8
60	6.0	13.6
65	6.5	14.4
70	7.0	15.2
75	7.5	16.0
80	8.0	16.8
85	8.5	17.6
90	9.0	18.4
95	9.5	19.2
100	10.0	20.0

**Temperature table**

MR: 0...+50 °C

°C	U <sub>A</sub> in V	I <sub>A</sub> in mA
0	0	4.0
5	1.0	5.6
10	2.0	7.2
15	3.0	8.8
20	4.0	10.4
25	5.0	12.0
30	6.0	13.6
35	7.0	15.2
40	8.0	16.8
45	9.0	18.4
50	10.0	20.0

Type/WG02	Measuring Range		PM	CO2	Equipment Display	Item No.	Price
	Humidity	Temperature					
<b>RPS-SD</b>			(switchable)				
RPS-SD	-	-	0... 50 µg/m <sup>3</sup> 0...100 µg/m <sup>3</sup> 0...300 µg/m <sup>3</sup> 0...500 µg/m <sup>3</sup>	-		1501-2110-1001-000	<b>292,47 €</b>
<b>RFTM-PS-W</b>			(switchable)	(switchable)			
RFTM-PS-W	0...100% r.H.	0...+50 °C	0... 50 µg/m <sup>3</sup> 0...100 µg/m <sup>3</sup> 0...300 µg/m <sup>3</sup> 0...500 µg/m <sup>3</sup>	-	W	1501-2116-7301-000	<b>381,51 €</b>
RFTM-PS-W LCD	0...100% r.H.	0...+50 °C	(4x as above)	-	W ■	1501-2116-7321-000	<b>463,51 €</b>
<b>RFTM-PS-CO2-W</b>							
RFTM-PS-CO2-W	0...100% r.H.	0...+50 °C	0... 50 µg/m <sup>3</sup> 0...100 µg/m <sup>3</sup> 0...300 µg/m <sup>3</sup> 0...500 µg/m <sup>3</sup>	0...2000 ppm / 0...5000 ppm	W	1501-2113-7301-000	<b>444,16 €</b>
RFTM-PS-CO2-W LCD	0...100% r.H.	0...+50 °C	(4x as above)	0...2000 ppm / 0...5000 ppm	W ■	1501-2113-7321-000	<b>491,63 €</b>
Outputs:	<b>0-10V or 4...20mA</b> (selectable via DIP switches, selected variant applies for all outputs) – <i>Standard</i> room sensor <b>RPS-SD</b> with fixed output 0-10V!						
Equipment:	<b>W = changeover contact</b> – <i>Standard</i> room sensor <b>RPS-SD</b> without changeover contact!						
Note:	These units must <b>not</b> be used as safety-relevant devices!						

**Room CO2 and temperature sensor or measuring transducer, in-wall in the panel switch programme, with active output**

The room sensor **AERASGARD® FSCO2 / FSTM-CO2** in the in-wall housing is used for measuring the CO2 content and temperature of the air. It converts the measured values into a standard signal of 0-10 V.

The CO2 content of the air is measured using an optical NDIR sensor (non-dispersive infra-red technology). A digital, long-term stable sensor is used for temperature measurement.

The in-wall sensor is mounted in high-quality panel switch programmes, ideally of the brands Gira, Berker, Merten, Jung, Siemens or Busch-Jaeger (using in-wall adapters) either individually or in combination with light switches, socket outlets, etc.

It is used in non-aggressive, dust-free environments, in refrigeration, air conditioning and clean room technology, and in interior rooms, such as living rooms, offices, hotels, etc.

**TECHNICAL DATA**

Power supply:	24 V AC / DC (± 10 %)
Power consumption:	< 1.5 W / 24 V DC; < 2.9 VA / 24 V AC

**CARBON DIOXIDE [CO2]**

Sensor, CO2:	<b>optical NDIR sensor</b> (non-dispersive infra-red technology), with manual calibration (via zero button) and automatic calibration (fixed)
Long-term stability:	< 2 % in 15 years
Measuring range, CO2:	0...2000 ppm
Output, CO2:	0-10 V
Measuring accuracy, CO2:	typically ± 30 ppm ± 3 % of measured value
Temperature dependence, CO2:	± 5 ppm / °C or ± 0.5 % of measured value / °C (whichever is higher)
Pressure dependence:	± 0.13 % / mm Hg
Gas exchange:	by diffusion
Warm up time:	approx. 1 hour
Response time:	< 2 minutes

**TEMPERATURE**

Sensor:	<b>digital temperature sensor,</b> low hysteresis, high long-term stability
Long-term stability:	± 1 % per year
Measuring range:	0...+50 °C
Deviation, temperature:	typically ± 0.8 K at +25 °C
Output, temperature:	0-10 V

Mounting:	in-wall flush box Ø 55 mm
Electrical connection:	1.0-2.5 mm <sup>2</sup> , via plug terminals
Ambient temperature:	Storage -35...+85 °C; Operation 0...+50 °C
Permitted humidity:	max. 90 % r.H., non-precipitating air
Medium:	clean air and other non-aggressive, non-combustible gases
Protection class:	III (according to EN 60 730)
Protection type:	IP 20 (according to 60 529)
Standards:	CE-conformity, electromagnetic compatibility according to EN 61 326, EMC Directive 2014 / 30 / EU

**SWITCH PROGRAMME**

Manufacturer:	GIRA System 55 (other switch programmes, manufacturers, colours as well as prices available upon request)
Housing:	plastic, the standard colour is pure glossy white (similar to RAL 9010) (other colours are available upon request with colour variants depending on the respective light switch programme)

Mounting diagram in-wall

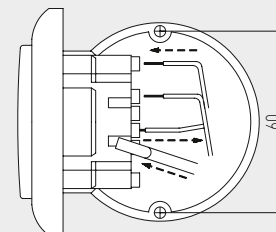

Connection diagram FSCO2

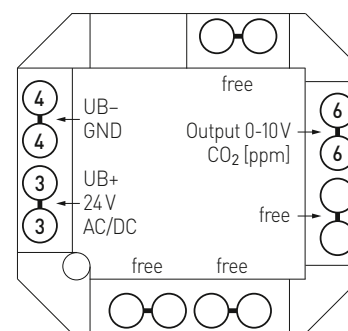

Connection diagram FSTM-CO2

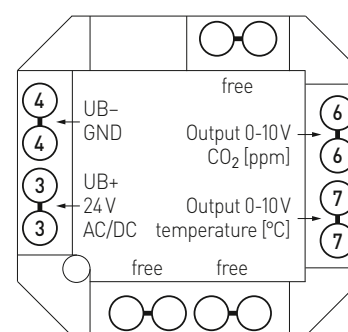

Schematic diagram FSFTM-CO2

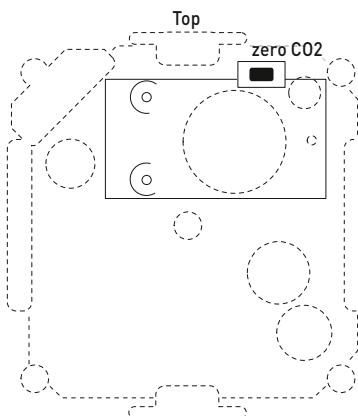



S+S REGELTECHNIK

AERASGARD® FSC02  
AERASGARD® FSTM-C02

Room CO2 and temperature sensor or measuring transducer,  
in-wall in the panel switch programme,  
with active output



Dimensional drawing

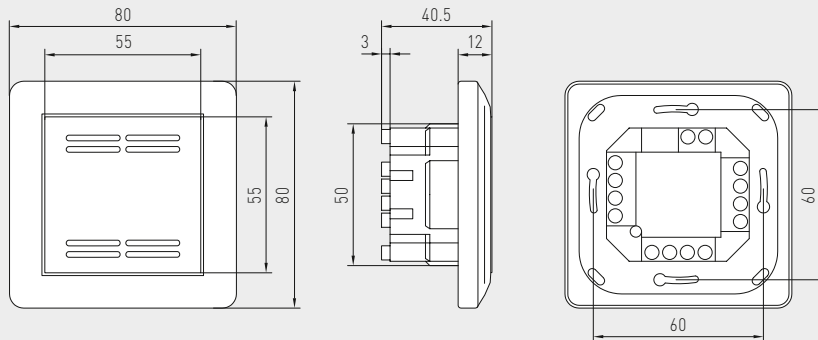

FSC02  
FSTM-C02

FSC02  
FSTM-C02



CO2 content table  
MR: 0...2000 ppm

ppm	U <sub>A</sub> [V]
0	0.00
350	1.75
400	2.00
450	2.25
500	2.50
550	2.75
600	3.00
700	3.50
800	4.00
900	4.50

Continued to the right ...

ppm	U <sub>A</sub> [V]
1000	5.0
1100	5.5
1200	6.0
1300	6.5
1400	7.0
1500	7.5
1600	8.0
1700	8.5
1800	9.0
1900	9.5
2000	10.0

Temperature table  
MR: 0...+50 °C

°C	U <sub>A</sub> [V]
0	0.0
5	1.0
10	2.0
15	3.0
20	4.0
25	5.0
30	6.0
35	7.0
40	8.0
45	9.0
50	10.0

AERASGARD® FSC02 Room CO2 sensor or measuring transducer, in-wall  
AERASGARD® FSTM-C02 Room temperature and CO2 sensor or measuring transducer, in-wall

Type / WG02	Measuring Range CO2	Temperature	Output CO2	Temperature	Item No.	Price
<b>FSC02</b>						
FSC02-U	0...2000 ppm	-	0-10 V	-	1501-9120-1001-162	321,81 €
<b>FSTM-C02</b>						
FSTM-C02-U	0...2000 ppm	0...+50 °C	0-10 V	0-10 V	1501-9122-1001-162	326,32 €

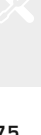
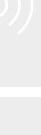
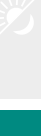

**On-wall CO2 sensor and measuring transducer, self-calibrating, with multi-range switching and active/switching output**

Maintenance-free on-wall sensor **AERASGARD® ACO2-SD** with active output, automatic calibration (fixed), in an impact-resistant plastic housing with quick-locking screws, for determining the CO2 content of the air (0...2000 ppm/0...5000 ppm). The measuring transducer converts the measured values into a standard signal of 0-10V.

Maintenance-free on-wall sensor **AERASGARD® ACO2-W** with active/switching output, automatic calibration (can be deactivated), in an impact-resistant plastic housing with quick-locking screws, optionally with/without display, for determining the CO2 content of the air (0...2000 ppm/0...5000 ppm). The measuring transducer converts the measured values into a standard signal of 0-10V or 4...20 mA (switchable).

The sensor is used in offices, hotels, convention centres, apartments, shops, etc. for the purpose of evaluating the indoor climate. This enables energy-saving room ventilation on an as-needed basis, thereby reducing operating costs and improving well-being. One sensor for every 30 m<sup>2</sup> of room area is recommended.

The CO2 measurement is performed using an optical **NDIR sensor** (non-dispersive infra-red technology). The detection range is calibrated for standard applications such as monitoring residential rooms and conference rooms.

For more information, see the start of the chapter.

**TECHNICAL DATA**

Power supply:	24 V AC / DC (± 10 %)
Power consumption:	< 1.5 W / 24 V DC typical; < 2.9 VA / 24 V AC typical; Peak current 200 mA
Sensor:	optical NDIR sensor (non-dispersive infra-red technology), with manual calibration (via zero button), <b>ACO2-SD</b> with automatic calibration (fixed) <b>ACO2-W</b> with automatic calibration (can be deactivated via DIP switches)
Measuring range:	<b>Multi-range switching</b> (selectable via DIP switches) 0...2000 ppm; 0...5000 ppm
Output:	<b>ACO2-SD</b> 0-10V (fixed) <b>ACO2-W</b> 0-10V or 4...20 mA, working resistance < 800 Ω (selectable via DIP switches), with offset potentiometer (± 10 % of the measuring range)
Relay output:	<b>ACO2-SD</b> without changeover contact <b>ACO2-W</b> with potential-free <b>changeover contact</b> (24 V / 1 A), switchpoint adjustable
Measuring accuracy:	typically ± 30 ppm ± 3 % of measured value
Temperature dependence:	± 5 ppm / °C or ± 0.5 % of measured value / °C (whichever is higher)
Pressure dependence:	± 0.13 % / mm Hg
Long-term stability:	< 2 % in 15 years
Gas exchange:	by diffusion
Warm up time:	approx. 1 hour
Ambient temperature:	-10...+60 °C
Response time:	approx. 1 minute
Electrical connection:	0.14 - 1.5 mm <sup>2</sup> , via screw terminals
Housing:	plastic, UV-resistant, material polyamide, 30 % glass-globe reinforced, with quick-locking screws (slotted / Phillips head combination), colour traffic white (similar to RAL 9016)
Housing dimensions:	126 x 90 x 50 mm (Tyr 2)
Cable connection:	<b>cable gland</b> , plastic (M 16 x 1.5; with strain relief, exchangeable, max. inner diameter 10.4 mm) or <b>M12 connector</b> according to DIN EN 61076-2-101 (optional on request)
Process connection:	by screws
Protection class:	III (according to EN 60 730)
Protection type:	<b>IP 65</b> (according to EN 60 529)
Standards:	CE conformity, electromagnetic compatibility according to EN 61 326, EMC Directive 2014 / 30 / EU
Optional:	<b>with display</b> (see <b>AERASGARD® AFTM-LQ-CO2</b> ) for displaying the actual CO2 content in ppm
<b>ACCESSORIES</b>	see table

Schematic diagram **ACO2 - SD**

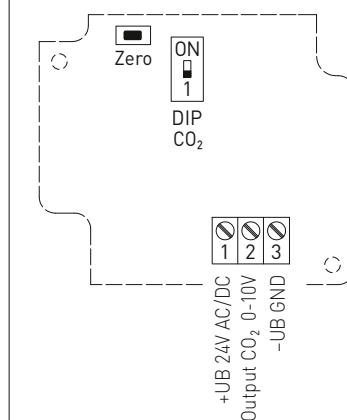

Connecting diagram **ACO2 - SD**

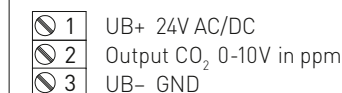

Schematic diagram **ACO2 - W**

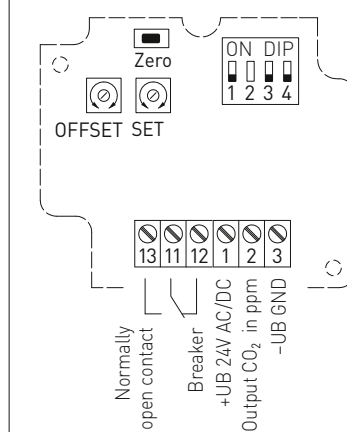

Connecting diagram **ACO2 - W**

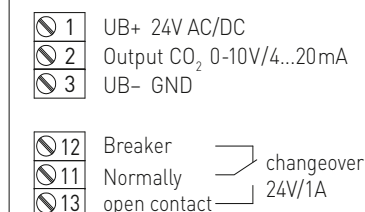



S+S REGELTECHNIK

AERASGARD® AC02-W  
AERASGARD® AC02-SD

On-wall CO2 sensor and measuring transducer,  
self-calibrating, with multi-range switching  
and active/switching output

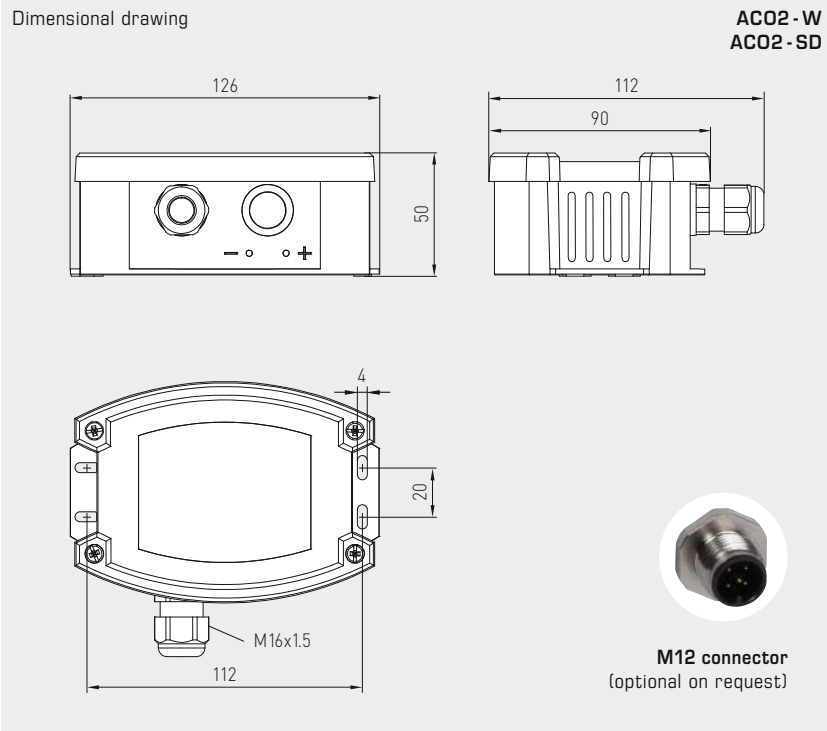

AC02-W  
AC02-SD



WS-03  
Weather and sun protection hood  
(optional)



DIP switch	AC02-W
<b>CO2 content</b>	<b>DIP 1</b>
0...2000 ppm (default)	OFF
0...5000 ppm	<b>ON</b>
<b>CO2 automatic zero point</b>	<b>DIP 3</b>
deactivated	OFF
activated (default)	<b>ON</b>
<b>Output</b>	<b>DIP 4</b>
Voltage 0-10V (default)	OFF
Current 4...20mA	<b>ON</b>
Note: <b>DIP 2</b> is not assigned!	

DIP switch	AC02-SD
<b>CO2 content</b>	<b>DIP 1</b>
0...2000 ppm (default)	OFF
0...5000 ppm	<b>ON</b>

AERASGARD® AC02-SD On-wall CO2 sensor and measuring transducer, *Standard*  
AERASGARD® AC02-W On-wall CO2 sensor and measuring transducer, *Premium*

Type / WG02B	Measuring Range CO2	Output CO2	Equipment	Display	Item No.	Price
<b>AC02-SD</b>	(switchable)	(fixed)				
AC02-SD-U	0...2000 ppm / 0...5000 ppm	0-10V	-		1501-7110-1001-200	233,15 €
<b>AC02-W</b>	(switchable)	(switchable)				
AC02-W	0...2000 ppm / 0...5000 ppm	0-10V / 4...20mA	changeover contact		1501-7110-7301-200	334,50 €
AC02-W LCD	0...2000 ppm / 0...5000 ppm	0-10V / 4...20mA	changeover contact, display	■	see <b>AFTM-LQ-C02</b>	
Optional:	Cable connection with <b>M12 connector</b> according to DIN EN 61076-2-101 (on request)					
<b>Note:</b>	This unit <b>must not</b> be used as safety-relevant device!					

ACCESSORIES						
<b>WS-03</b>	<b>Weather and sun protection hood, 200 x 180 x 150 mm, stainless steel V2A (1.4301)</b>				7100-0040-6000-000	42,61 €
For further information see last chapter!						



**Multifunctional on-wall sensors and measuring transducers,  
 for humidity, temperature, CO2 content and air quality (VOC),  
 calibratable, with active/switching output**

Maintenance-free on-wall sensor **AERASGARD® ATM - CO2 - SD** with active output, automatic calibration, in an impact-resistant plastic housing with quick-locking screws, for determining the CO2 content of the air (0...2000 ppm/0...5000 ppm) and the temperature (-35...+80 °C). The measuring transducer converts the measured values into a standard signal of 0-10V.

Maintenance-free on-wall sensor **AERASGARD® AFTM - LQ - CO2 - W** with active/switching output, automatic calibration, in an impact-resistant plastic housing with quick-locking screws, optionally with/without Display, for determining the CO2 content of the air (0...2000 ppm/0...5000 ppm), the quality (0...100 % VOC), the temperature (-35...+80 °C) as well as the relative air humidity (0...100% r.H). The measuring transducer converts the measured values into a standard signal of 0-10V or 4...20mA (switchable).

The sensor is used in offices, hotels, convention centres, apartments, shops, etc. for the purpose of evaluating the indoor climate. This enables energy-saving room ventilation on an as-needed basis, thereby reducing operating costs and improving well-being. One sensor for every 30 m² of room area is recommended.

A long-term stable, **digital humidity and temperature sensor** guarantees exact measurement results. The CO2 measurement is performed using an optical **NDIR sensor** (non-dispersive infra-red technology). The detection range is calibrated for standard applications such as monitoring residential rooms and conference rooms. The air quality is detected by a **VOC sensor** (mixed gas sensor for volatile organic substances). This sensor determines the loading of the room air due to contaminated gases such as cigarette smoke, body perspiration, exhaled breathing air, solvent vapours, emissions, etc. With regard to the expected air contamination, low, medium or high VOC sensitivity can be selected. As an alternative, use IAQ categories (from excellent to unhealthy) following the guidelines of the German Federal Environmental Agency to assess the room air.

For more information, see the start of the chapter.

### TECHNICAL DATA

Voltage supply:	24 V AC / DC (± 10 %)
Power consumption:	< 4.8 W / 24V DC typical; < 6.8 VA / 24 V AC typical; peak current 200 mA
Outputs:	<b>Axx-SD</b> 0-10V (fixed) <b>Axx-W</b> 0-10V or 4...20 mA, working resistance < 800 Ω (selectable via DIP switches, selected variant applies for all outputs), with offset potentiometer (± 10 % of the measuring range)
Relay output:	<b>Axx-SD</b> without changeover contact <b>Axx-W</b> with potential-free <b>changeover contact</b> (24 V / 1 A)

### HUMIDITY

Sensors:	<b>digital humidity sensor with integrated temperature sensor</b> , low hysteresis, high long-term stability
Sensor protection:	<b>plastic</b> sinter filter, Ø 16 mm, L = 35 mm, exchangeable (optional <b>metal</b> sinter filter, Ø 16 mm, L = 32 mm)
Measuring range, humidity:	0...100 % r. H.
Operating range, humidity:	0...95 % r. H. (without dew formation)
Deviation of humidity:	typically <b>± 2.0 %</b> (20...80 % r. H.) at +25 °C, otherwise ± 3.0 %
Output, humidity:	0-10 V or 4...20 mA (selectable via DIP switches)

### TEMPERATURE

Measuring range, temperature:	-35...+80 °C
Operating range, temperature:	-10...+60 °C
Temperature deviation:	typically ± 0.4 K at 25 °C
Output, temperature:	<b>Axx-SD</b> 0-10V (fixed) <b>Axx-W</b> 0-10V or 4...20 mA (selectable via DIP switches)

### AIR QUALITY (VOC)

Sensor, VOC:	VOC sensor (metal oxide) (VOC = volatile organic compounds), with manual calibration (using zero button) and automatic calibration (permanently active)
Measuring range, VOC:	0...100 % air quality; referred to calibrating gas; <b>multi-range switching</b> (selectable via DIP switches) VOC sensitivities (low/medium/high) or IAQ category (Indoor Air Quality)
Output, VOC:	0-10 V (0V = clean air, 10 V = polluted air) or 4...20 mA (selectable via DIP switches, switchpoint can be adjusted from 0...100 % of the output signal)
Measuring accuracy, VOC:	typically ± 20 % of final value (referred to calibrating gas)
Service life:	> 60 months (under normal load conditions) depending on the type of loading and gas concentration

### CARBON DIOXIDE (CO2)

Sensor, CO2:	optical NDIR sensor (non-dispersive infra-red technology), with manual calibration (via zero button), <b>Axx-SD</b> with automatic calibration (fixed) <b>Axx-W</b> with automatic calibration (can be deactivated via DIP switches)
Measuring range, CO2:	0...2000 ppm or 0...5000 ppm (selectable via DIP switches)
Output, CO2:	<b>Axx-SD</b> 0-10V (fixed) <b>Axx-W</b> 0-10V or 4...20 mA (selectable via DIP switches)
Measuring accuracy, CO2:	typically ± 30 ppm ± 3 % of measured value
Temperature dependence, CO2:	± 5 ppm / °C or ± 0.5 % of measured value / °C

continued on next page!



S+S REGELTECHNIK

# AERASGARD® ACO<sub>2</sub>-W / ALQ-CO<sub>2</sub>-W AERASGARD® AFTM-(LQ)-CO<sub>2</sub>-W / ATM-CO<sub>2</sub>-SD

Multifunctional on-wall sensors and measuring transducers,  
for humidity, temperature, CO<sub>2</sub> content and air quality (VOC),  
calibratable, with active/switching output



**Dimensional drawing**

**AFTM-LQ-CO<sub>2</sub>-W**

M12 connector (optional on request)

SF-K plastic sinter filter (standard)

SF-M metal sinter filter (optional)

**AFTM-LQ-CO<sub>2</sub>-W**  
with plastic sinter filter (standard)



**AFTM-LQ-CO<sub>2</sub>-W**  
with display and plastic sinter filter (standard)



TECHNICAL DATA		(continued)
Pressure dependence:	± 0.13 % / mm Hg	
Long-term stability:	< 2% in 15 years	
Gas exchange:	by diffusion	
Ambient temperature:	-10...+60 °C	
Response time:	< 2 minutes	
Electrical connection:	0.14 - 1.5 mm <sup>2</sup> , via screw terminals	
Housing:	plastic, UV-resistant, material polyamide, 30 % glass-globe reinforced, with quick-locking screws (slotted / Phillips head combination), colour traffic white (similar to RAL 9016), housing cover for display is transparent!	
Housing dimensions:	126 x 90 x 50 mm (Tyr 2)	
Cable connection:	<b>cable gland</b> , plastic (M 16 x 1.5; with strain relief, exchangeable, max. inner diameter 10.4 mm) <b>or</b> <b>M12 connector</b> according to DIN EN 61076-2-101 (optional on request)	
Protective tube:	<b>stainless steel V2A</b> (1.4301), Ø 16 mm, NL = 55 mm	
Process connection:	by screws	
Protection class:	III (according to EN 60 730)	
Protection type:	<b>IP 65</b> (according to EN 60 529)	
Standards:	CE conformity, electromagnetic compatibility according to EN 61 326, EMC Directive 2014/30/EU	
Optional:	three-line <b>display with illumination</b> , cutout approx. 70 x 40 mm (W x H), for displaying actual humidity, actual temperature, air quality and/or the actual CO <sub>2</sub> content	

Multifunctional on-wall sensors and measuring transducers,  
 for humidity, temperature, CO<sub>2</sub> content and air quality (VOC),  
 calibratable, with active/switching output

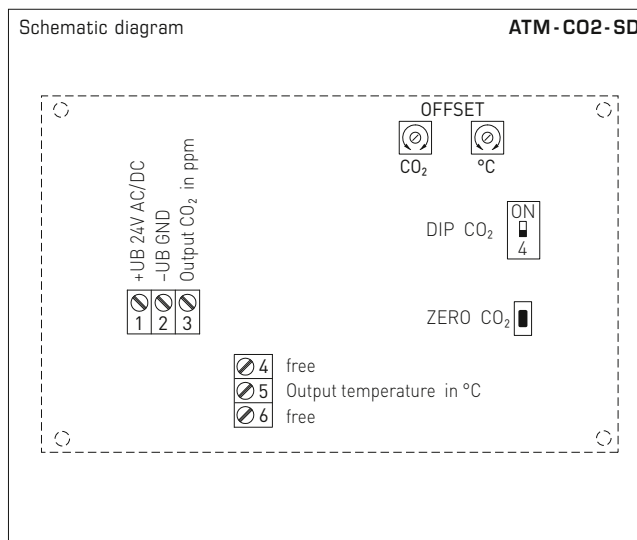
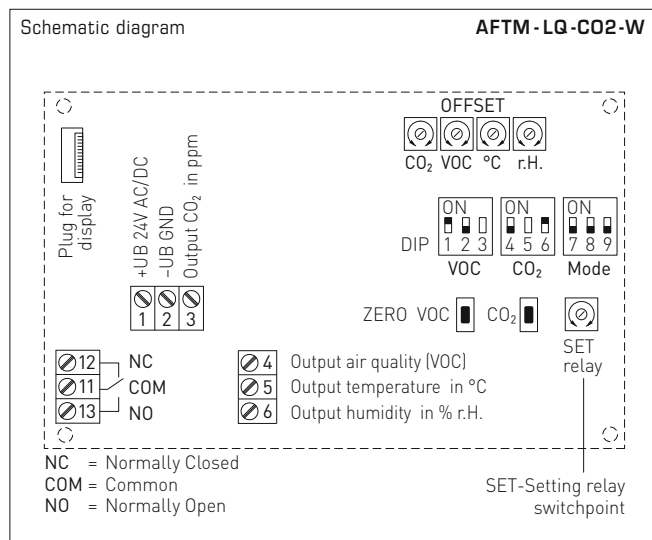

DIP switches	AFTM - LQ - CO2 - W	
<b>VOC sensitivity</b>	DIP 1	DIP 2
LOW	OFF	OFF
MEDIUM (default)	<b>ON</b>	OFF
HIGH	OFF	<b>ON</b>
<b>IAQ (Indoor Air Quality)</b>	<b>ON</b>	<b>ON</b>
<b>CO2 content</b>	DIP 4	
0...2000 ppm (default)	OFF	
0...5000 ppm	<b>ON</b>	
<b>CO2 automatic zero point</b>	DIP 6	
deactivated	OFF	
activated (default)	<b>ON</b>	
<b>Relay assignment</b>	DIP 7	DIP 8
CO <sub>2</sub> (default): 600...1900 ppm / 900...4700 ppm	OFF	OFF
VOC: 10...95%	<b>ON</b>	OFF
Temperature: -23...+74 °C	OFF	<b>ON</b>
Humidity: 10...95% r.H.	<b>ON</b>	<b>ON</b>
<b>Output</b>	DIP 9	
Voltage 0-10V (default)	OFF	
Current 4...20mA	<b>ON</b>	
Note: <b>DIP 3</b> and <b>DIP 5</b> are not assigned!		

DIP switches	ATM - CO2 - SD	
<b>CO2 content</b>	DIP 4	
0...2000 ppm (default)	OFF	
0...5000 ppm	<b>ON</b>	

Level	IAQ (Indoor Air Quality)	VOC
1	<b>excellent</b> no action required	<b>0...19%</b>
2	<b>good</b> prompt airing recommended	<b>20...39%</b>
3	<b>moderate</b> airing recommended	<b>40...59%</b>
4	<b>poor</b> increased airing required	<b>60...79%</b>
5	<b>unhealthy</b> intense airing necessary	<b>80...100%</b>

Table according to TVOC guidelines of the German Federal Environmental Agency to assess indoor air contamination  
 (Bundesgesundheitsbl - Gesundheitsforsch - Gesundheitsschutz 2007, 50: 990-1005)



S+S REGELTECHNIK

AERASGARD® ACO2-W / ALQ-CO2-W  
AERASGARD® AFTM-(LQ)-CO2-W / ATM-CO2-SD

Multifunctional on-wall sensors and measuring transducers,  
for humidity, temperature, CO2 content and air quality (VOC),  
calibratable, with active/switching output

AFTM-LQ-CO2-W  
with display



**Humidity table**

MR: 0...100% r. H.

% r.H.	U <sub>A</sub> in V	I <sub>A</sub> in mA
0	0	4.0
5	0.5	4.8
10	1.0	5.6
15	1.5	6.4
20	2.0	7.2
25	2.5	8.0
30	3.0	8.8
35	3.5	9.6
40	4.0	10.4
45	4.5	11.2
50	5.0	12.0
55	5.5	12.8

Continued at the right ...

% r.H.	U <sub>A</sub> in V	I <sub>A</sub> in mA
60	6.0	13.6
65	6.5	14.4
70	7.0	15.2
75	7.5	16.0
80	8.0	16.8
85	8.5	17.6
90	9.0	18.4
95	9.5	19.2
100	10.0	20.0

**Temperature table**

MR: -35...+80 °C

°C	U <sub>A</sub> in V	I <sub>A</sub> in mA
-35	0.0	4.0
-30	0.4	4.7
-25	0.9	5.4
-20	1.3	6.1
-15	1.7	6.8
-10	2.2	7.5
-5	2.6	8.2
0	3.0	8.9
+5	3.5	9.6
+10	3.9	10.3
+15	4.3	11.0
+20	4.8	11.7

Continued at the right ...

°C	U <sub>A</sub> in V	I <sub>A</sub> in mA
+25	5.2	12.3
+30	5.7	13.0
+35	6.1	13.7
+40	6.5	14.4
+45	7.0	15.1
+50	7.4	15.8
+55	7.8	16.5
+60	8.3	17.2
+65	8.7	17.9
+70	9.1	18.6
+75	9.6	19.3
+80	10.0	20.0

**AERASGARD® AC02-W / ALQ-CO2-W**  
**AERASGARD® AFTM-(LQ)-CO2-W / ATM-CO2-SD**



Multifunctional on-wall sensors and measuring transducers,  
 for humidity, temperature, CO2 content and air quality (VOC),  
 calibratable, with active/switching output

S+S REGELTECHNIK

Dimensional drawing

**AC02-W**  
**ALQ-CO2-W**

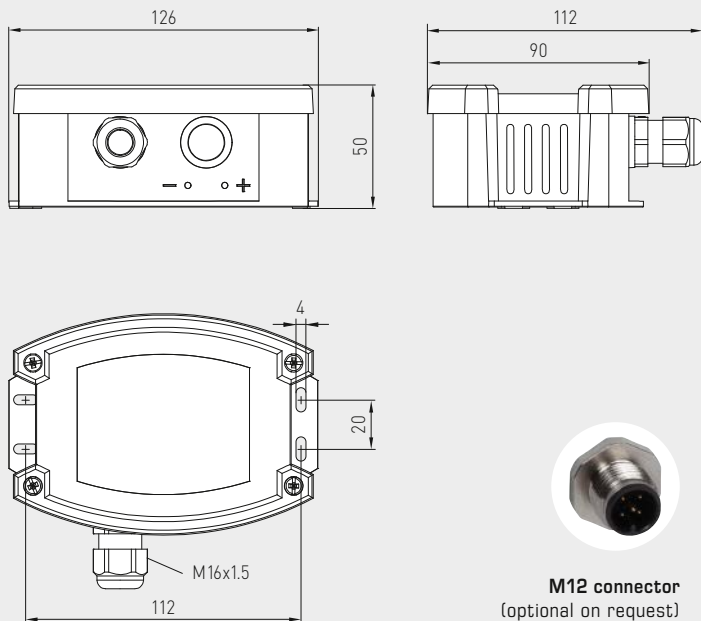

**AC02-W**  
**ALQ-CO2-W**



Dimensional drawing

**AFTM-CO2-W**  
**AFTM-LQ-CO2-W**  
**ATM-CO2-SD**

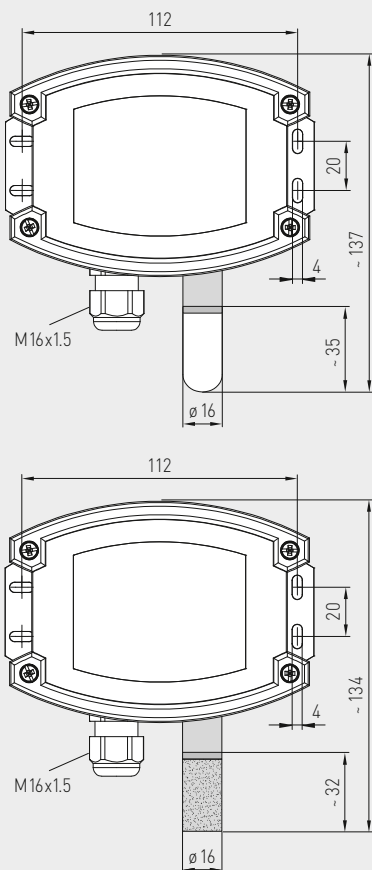

**SF-K**  
plastic sinter filter  
(standard)



**SF-M**  
metal sinter filter  
(optional)



**AFTM-CO2-W**  
**AFTM-LQ-CO2-W**  
**ATM-CO2-SD**  
with metal sinter filter  
(optional)







S+S REGELTECHNIK

# AERASGARD® ACO2-W / ALQ-CO2-W AERASGARD® AFTM-(LQ)-CO2-W / ATM-CO2-SD

Multifunctional on-wall sensors and measuring transducers,  
for humidity, temperature, CO2 content and air quality (VOC),  
calibratable, with active/switching output

## WS-03

Weather and sun protection hood  
(optional)



## AFTM-CO2-W AFTM-LQ-CO2-W ATM-CO2-SD

with plastic sinter filter  
(standard)



AERASGARD® ATM-CO2-SD	On-wall temperature and CO2 sensor, <i>Standard</i>
AERASGARD® ACO2-W	On-wall CO2 sensor, <i>Premium</i>
AERASGARD® ALQ-CO2-W	On-wall air quality (VOC) and CO2 sensor, <i>Premium</i>
AERASGARD® AFTM-CO2-W	Multifunctional on-wall sensor for humidity, temperature and CO2 content, <i>Deluxe</i>
AERASGARD® AFTM-LQ-CO2-W	Multifunctional on-wall sensor for humidity, temperature, CO2 content and air quality (VOC), <i>Deluxe</i>

Typ/WG02	Measuring Range				Equipment Display	Item No. (Baldur 2)	Price
	Humidity	Temperature	CO2	VOC			
<b>ATM-CO2-SD</b>			(switchable)				
ATM-CO2-SD-U	-	-35...+80 °C	0...2000 / 5000 ppm	-	-	1501-7112-1001-200	<b>296,79 €</b>
<b>ACO2-W</b>			(switchable)				
ACO2-W (without display)	-	-	0...2000 / 5000 ppm	-	W	see <b>ACO2-W / ACO2-SD</b>	
ACO2-W LCD	-	-	0...2000 / 5000 ppm	-	W ■	1501-7110-7371-200	<b>391,86 €</b>
<b>ALQ-CO2-W</b>			(switchable)				
ALQ-CO2-W	-	-	0...2000 / 5000 ppm	0...100 %	W	1501-7111-7301-500	<b>446,15 €</b>
ALQ-CO2-W LCD	-	-	0...2000 / 5000 ppm	0...100 %	W ■	1501-7111-7371-500	<b>503,69 €</b>
<b>AFTM-CO2-W</b>			(switchable)				
AFTM-CO2-W	0...100 % r.H.	-35...+80 °C	0...2000 / 5000 ppm	-	W	1501-7116-7301-200	<b>428,49 €</b>
AFTM-CO2-W LCD	0...100 % r.H.	-35...+80 °C	0...2000 / 5000 ppm	-	W ■	1501-7116-7371-200	<b>514,18 €</b>
<b>AFTM-LQ-CO2-W</b>			(switchable)				
AFTM-LQ-CO2-W	0...100 % r.H.	-35...+80 °C	0...2000 / 5000 ppm	0...100 %	W	1501-7118-7301-500	<b>561,12 €</b>
AFTM-LQ-CO2-W LCD	0...100 % r.H.	-35...+80 °C	0...2000 / 5000 ppm	0...100 %	W ■	1501-7118-7371-500	<b>671,68 €</b>
Outputs:	0-10V or 4...20 mA (selectable via DIP switches, selected variant applies for all outputs) – <i>Standard</i> on-wall sensor <b>ATM-CO2-SD</b> with fixed output 0-10V!						
Equipment:	<b>W = changeover contact</b> – <i>Standard</i> on-wall sensor <b>ATM-CO2-SD</b> without changeover contact!						
Optional:	Cable connection with <b>M12 connector</b> according to DIN EN 61076-2-101 (on request)						
Note:	This unit <b>must not</b> be used as safety-relevant device!						
<b>ACCESSORIES</b>							
<b>SF-M</b>	<b>Metal sinter filter</b> , Ø 16 mm, L = 32 mm, exchangeable stainless steel <b>V4A</b> (1.4404)					7000-0050-2200-100	<b>40,31 €</b>
<b>WS-03</b>	<b>Weather and sun protection hood</b> , 200 x 180 x 150 mm, stainless steel <b>V2A</b> (1.4301)					7100-0040-6000-000	<b>42,61 €</b>

For further information see last chapter!

**Fine dust sensor / particulate sensor,  
on-wall sensor and measuring transducer, with multi-range switching  
and active output**

Maintenance-free on-wall sensor **AERASGARD® APS-SD** with active output, in an impact-resistant plastic housing with quick-locking screws, for measuring the fine-dust content (0...500 µg/m³). The measuring transducer converts the measured values into a standard signal of 0-10V.

The sensor is used in offices, hotels, convention centres, apartments, shops, etc. and is used for evaluation of the indoor climate. This enables energy-saving, demand-based room ventilation, thereby reducing operating costs and improving well-being. One sensor for every 30m² of room area is recommended.

An optical **fine dust sensor** precisely detects **particulate (PM)** of the size category 0.3 to 10 micrometres. The sensor is factory-calibrated.

**TECHNICAL DATA**

Power supply:	24 V AC / DC (± 10%)
Power consumption:	typical < 1.5 W / 24 V DC; < 2.9 VA / 24 V AC
Output:	0-10 V
<b>FINE DUST (PM)</b>	
Sensor (PM):	optical <b>particulate sensor (PM = particulate matter), fine-dust sensor</b> with laser- and soiling-resistant technology
Measuring range:	multi-range switching (selectable via DIP switches) 0...50, 0...100, 0...300 or 0...500 µg/m³
Particle size:	<b>PM 2.5</b> (0.3...2.5 µm); <b>PM 10</b> (0.3...10 µm)
Measuring accuracy:	typical ± 10 µg/m³ (± 10% of the measured value) for PM 2.5 typical ± 25 µg/m³ (± 25% of the measured value) for PM 10
Long-term stability:	± 1.25 µg/m³ (± 1.25% of measured value/year)
Service life:	> 10 years
Response time:	< 2 minutes
Warm-up time:	approx. 1 hour
Ambient temperature:	0...+50 °C
Permitted humidity:	0...95% r. H. (non-precipitating air)
Housing:	plastic, UV-resistant, polyamide material, 30% glass-globe reinforced, with quick-locking screws (slotted/Phillips head combination) colour traffic white (similar to RAL 9016)
Housing dimensions:	126 x 90 x 50 mm (Tyr 2)
Cable connection:	<b>cable gland</b> plastic (M 16 x 1.5; with strain relief, exchangeable, max. inner diameter 10.4 mm) <b>or</b> <b>M12 connector</b> according to DIN EN 61076-2-101 (optional on request)
Electrical connection:	0.14–1.5 mm², via screw terminals
Process connection:	via screws
Protection class:	III (according to EN 60 730)
Safety class:	<b>IP 30</b> (according to EN 60 529)
Standards:	CE-conformity, electromagnetic compatibility according to EN 61 326, EMC Directive 2014 / 30 / EU

DIP switch	APS-SD	
<b>Fine dust (PM) Measuring range</b>	DIP 1	DIP 2
0...50 µg/m³	OFF	OFF
0...100 µg/m³ (default)	ON	OFF
0...300 µg/m³	OFF	ON
0...500 µg/m³	ON	ON
<b>Fine dust (PM) Particle size</b>	DIP 3	
PM 2.5 (default)	ON	
PM 10	OFF	
Note:	DIP 4 is not assigned !	

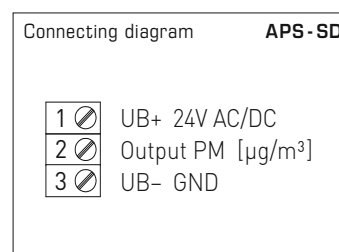
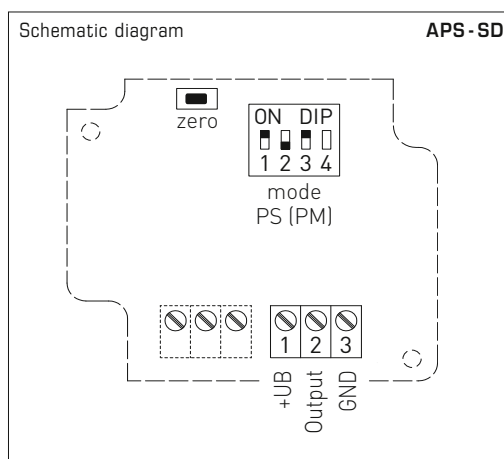



**NEW**

S+S REGELTECHNIK

AERASGARD® APS-SD

Fine dust sensor / particulate sensor,  
on-wall sensor and measuring transducer, with multi-range switching  
and active output



Dimensional drawing

APS-SD

APS-SD

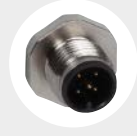
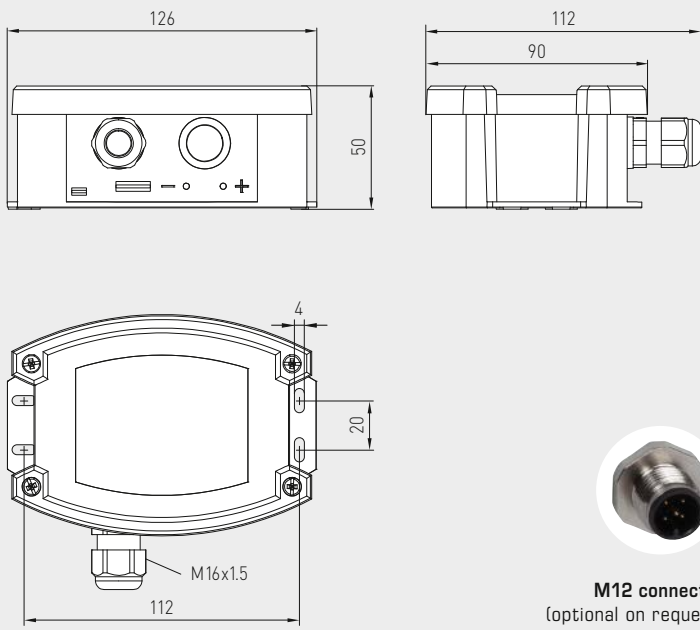

**M12 connector**  
(optional on request)

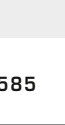

AERASGARD® APS-SD					
On-wall fine dust sensor / fine dust sensor / particulate sensor (PM), Standard					
Type / WG02	Measuring Range	Particle size	Output	Item No.	Price
<b>APS-SD</b>	(switchable)	(switchable)			
APS SD-U	0... 50 µg/m³ 0... 100 µg/m³ 0... 300 µg/m³ 0... 500 µg/m³	PM 2.5 PM 10	0-10V	1501-7130-1001-000	<b>393,88 €</b>
Optional: Cable connection with <b>M12 connector</b> according to DIN EN 61076-2-101 (on request)					
<b>Note:</b> This unit <b>must not</b> be used as safety-relevant device!					

**Duct air quality sensors (VOC) and measuring transducers, including installation flange, self-calibrating, with multi-range switching and active/switching output**

**Patented quality product (patent no. DE 10 2014 010 719.1)**

Maintenance-free duct sensor **AERASGARD® KLQ-SD** with active output, automatic calibration, in a compact plastic housing with snap-on lid, for determining the air quality (0...100% VOC). The measuring transducer converts the measured values into a standard signal of 0-10 V.

Maintenance-free duct sensor **AERASGARD® KLQ-W** with active/switching output, automatic calibration, in a compact plastic housing with quick-locking screws, for determining the air quality (0...100% VOC). The measuring transducer converts the measured values into a standard signal of 0-10 V or 4...20 mA (switchable).

The sensor is used in offices, hotels, convention centres, apartments, shops, etc. for the purpose of evaluating the indoor climate. This enables energy-saving room ventilation on an as-needed basis, thereby reducing operating costs and improving well-being.

The air quality is detected by a **VOC sensor** (mixed gas sensor for volatile organic substances). This sensor determines the loading of the room air due to contaminated gases such as cigarette smoke, body perspiration, exhaled breathing air, solvent vapours, emissions etc. With regard to the expected air contamination, low, medium or high VOC sensitivity can be selected. As an alternative, use IAQ categories (from excellent to unhealthy) following the guidelines of the German Federal Environmental Agency to assess the room air.

For more information, see the start of the chapter.



**TECHNICAL DATA**

Power supply:	24 V AC / DC (± 10%)
Power consumption:	< 1.5 W / 24 V DC typical; < 2.9 VA / 24 V AC typical
Sensor:	VOC sensor (metal oxide) (VOC = volatile organic compounds), with manual calibration (via zero button), with automatic calibration (permanently active)
Measuring range:	0...100% air quality; referred to calibrating gas; <b>multi-range switching</b> (selectable via DIP switches) VOC sensitivities (low/medium/high) or IAQ category (Indoor Air Quality)
Output:	(0 V = clean air, 10 V = polluted air) <b>KLQ-SD</b> 0-10 V (fixed) <b>KLQ-W</b> 0-10 V or 4...20 mA, working resistance < 800 Ω (selectable via DIP switches), with offset potentiometer (± 10% of the measuring range)
Relay output:	<b>KLQ-SD</b> without changeover contact <b>KLQ-W</b> with potential-free <b>changeover contact</b> (24 V / 1 A), switchpoint adjustable
Measuring accuracy:	typically ± 20% of final value (referred to calibrating gas)
Service life:	> 60 months (under normal load conditions), depending on the type of loading and gas concentration
Gas exchange:	by diffusion
Warm-up time:	approx. 1 hour
Response time:	approx. 1 minute, minimum flow rate 0.3 m/s (air)
Ambient temperature:	-10...+60 °C
Electrical connection:	0.14 - 1.5 mm <sup>2</sup> , via terminals
Housing:	plastic, UV-resistant, material polyamide, 30% glass-globe-reinforced, colour traffic white (similar to RAL 9016), <b>KLQ-SD</b> with snap-on lid, <b>KLQ-W</b> with quick-locking screws (slotted / Phillips head combination)
Housing dimensions:	72 x 64 x 37.8 mm (Tyr 1/Tyr 01 without display)
Cable connection:	<b>cable gland</b> , plastic (M 16 x 1.5; with strain relief, exchangeable, max. inner diameter 10.4 mm) or <b>M12 connector</b> according to DIN EN 61076-2-101 (optional on request)
Protective tube:	<b>PLEUROFORM™</b> , material polyamide (PA6), with torsion protection, Ø 20 mm, NL = 202.5 mm, v <sub>max</sub> = 30 m/s (air)
Process connection:	by mounting flange, plastic (included in the scope of delivery)
Protection class:	III (according to EN 60 730)
Protection type:	<b>KLQ-SD</b> <b>IP54</b> (according to EN 60 529)* Housing tested, TÜV SÜD, Report No. 713160960A (Tyr 01) <b>KLQ-W</b> <b>IP65</b> (according to EN 60 529)* Housing tested, TÜV SÜD, Report No. 713139052 (Tyr 1) * Housing in the built-in state (permeable PLEUROFORM: IP 30)
Standards:	CE conformity, electromagnetic compatibility according to EN 61 326, EMC Directive 2014 / 30 / EU
<b>ACCESSORIES</b>	see last chapter

**MFT-20-K**  
Mounting flange,  
plastic





Dimensional drawing

KLQ-W  
KLQ-SD

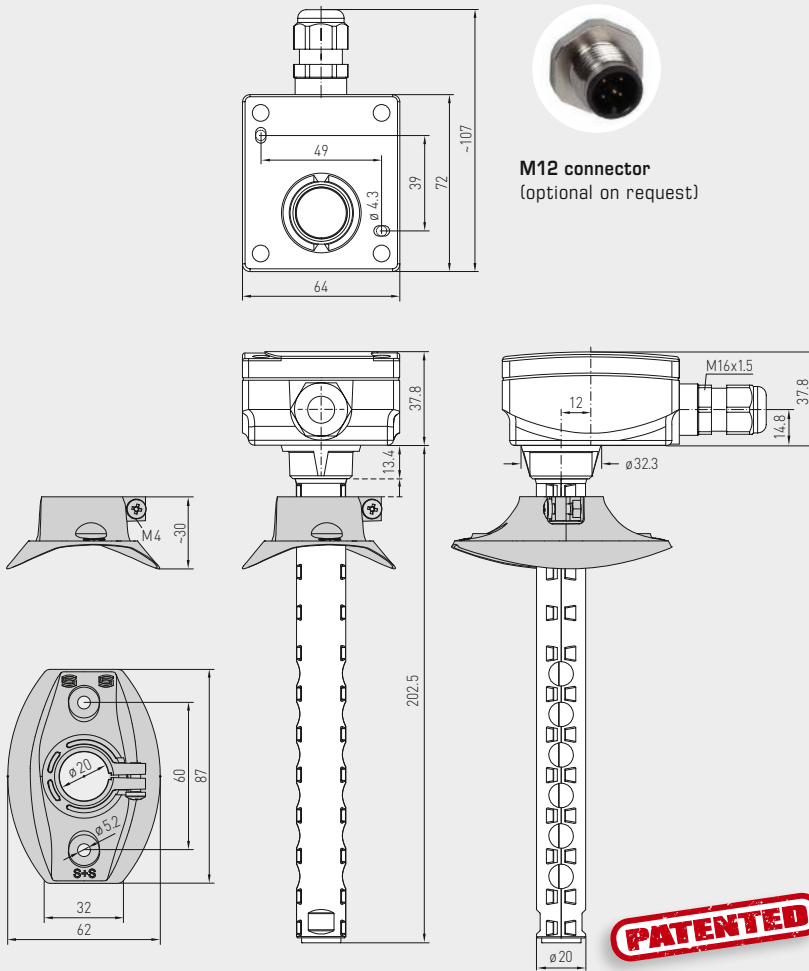

M12 connector  
(optional on request)

**PATENTED**

KLQ-SD  
with snap-on lid  
(IP54)



KLQ-W  
with quick-locking  
screws (IP65)



Mounting diagram

KLQ-W  
KLQ-SD

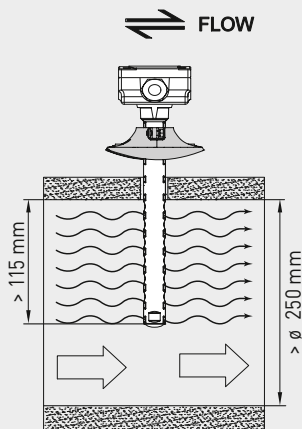



Duct air quality sensors (VOC) and measuring transducers,  
including installation flange, self-calibrating, with multi-range switching  
and active/switching output

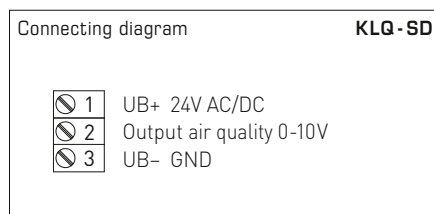
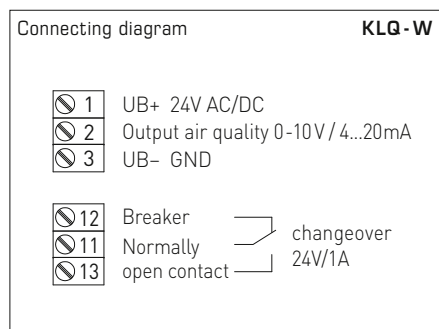
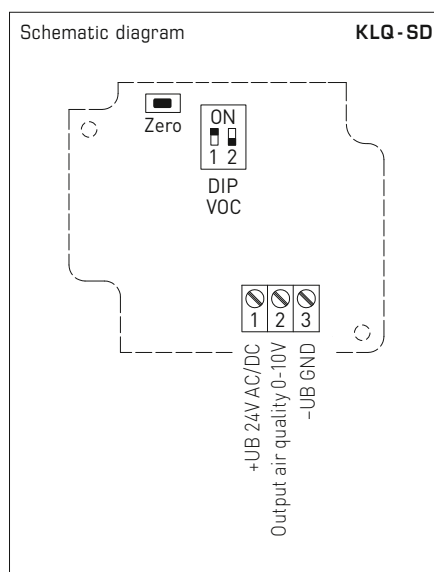
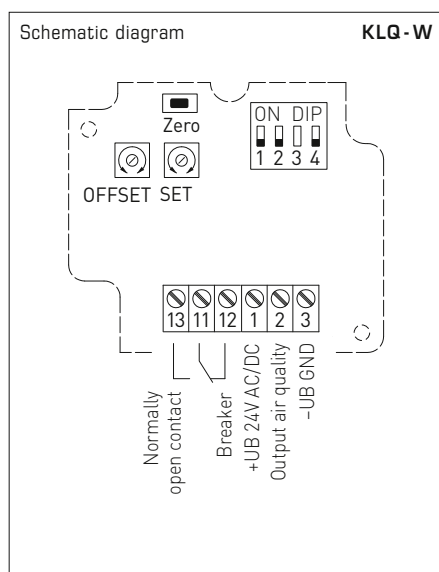

DIP switches		KLQ-W	
<b>VOC sensitivity</b>	<b>DIP 1</b>	<b>DIP 2</b>	
LOW	OFF	OFF	
MEDIUM (default)	<b>ON</b>	OFF	
HIGH	OFF	<b>ON</b>	
<b>IAQ (Indoor Air Quality)</b>	<b>ON</b>	<b>ON</b>	
<b>Output</b>		<b>DIP 4</b>	
Voltage 0-10V (default)		OFF	
Current 4...20mA		<b>ON</b>	
Note: <b>DIP 3</b> is not assigned!			

DIP switches		KLQ-SD	
<b>VOC sensitivity</b>	<b>DIP 1</b>	<b>DIP 2</b>	
LOW	OFF	OFF	
MEDIUM (default)	<b>ON</b>	OFF	
HIGH	OFF	<b>ON</b>	
<b>IAQ (Indoor Air Quality)</b>	<b>ON</b>	<b>ON</b>	

Level	IAQ (Indoor Air Quality)	VOC
1	<b>excellent</b> no action required	0...19%
2	<b>good</b> prompt airing recommended	20...39%
3	<b>moderate</b> airing recommended	40...59%
4	<b>poor</b> increased airing required	60...79%
5	<b>unhealthy</b> intense airing necessary	80...100%

Table according to TVOC guidelines of the German Federal Environmental Agency to assess indoor air contamination  
*(Bundesgesundheitsbl – Gesundheitsforsch – Gesundheitsschutz 2007, 50: 990–1005)*



S+S REGELTECHNIK

AERASGARD® KLQ-W  
AERASGARD® KLQ-SD

Duct air quality sensors (VOC) and measuring transducers,  
including installation flange, self-calibrating, with multi-range switching  
and active/switching output

KLQ-W  
Circuit board



Type / WG02	Measuring Range VOC	Output VOC	Equipment	Item No.	Price
<b>AERASGARD® KLQ-SD</b> Duct air quality sensor and measuring transducer, <i>Standard</i>					
<b>AERASGARD® KLQ-W</b> Duct air quality sensor and measuring transducer, <i>Premium</i>					
<b>KLQ-SD</b>		(fixed)		<b>IP 54</b>	
KLQ-SD-U	0...100 %	0-10 V	–	1501-3170-1001-500	<b>202,39 €</b>
<b>KLQ-W</b>		(switchable)		<b>IP 65</b>	
KLQ-W	0...100 %	0-10 V / 4...20 mA	changeover contact	1501-3150-7301-500	<b>211,27 €</b>
Optional:	Cable connection with <b>M12 connector</b> according to DIN EN 61076-2-101 (on request)				
Note:	This unit <b>must not</b> be used as safety-relevant device!				



Duct CO<sub>2</sub> sensors and measuring transducers,  
incl. mounting flange, self-calibrating, with multi-range switching  
and active / switching output

**Patented quality product (patent no. DE 10 2014 010 719.1)**

Maintenance-free duct sensor **AERASGARD® KCO2-SD** with active output, automatic calibration (fixed), in a compact plastic enclosure with snap-on lid, for determining the CO<sub>2</sub> content of the air (0...2000 ppm/0...5000 ppm). The measuring transducer converts the measured values into a standard signal of 0-10V.

Maintenance-free duct sensor **AERASGARD® KCO2-W** with active/switching output, automatic calibration (can be deactivated), in a compact plastic enclosure with quick-locking screws, optionally with/without display, for determining the CO<sub>2</sub> content of the air (0...2000 ppm/0...5000 ppm). The measuring transducer converts the measured values into a standard signal of 0-10V or 4...20mA (switchable).

The CO<sub>2</sub> sensor is used in offices, hotels, convention centres, apartments, shops, etc. for the purpose of evaluating the indoor climate. This enables energy-saving room ventilation on an as-needed basis, thereby reducing operating costs and improving well-being. One sensor for every 30m<sup>2</sup> of room area is recommended.

The CO<sub>2</sub> measurement is performed using an optical **NDIR sensor** (non-dispersive infra-red technology). The detection range is calibrated for standard applications such as monitoring residential rooms and conference rooms.

For more information, see the start of the chapter.

**TECHNICAL DATA**

Power supply:	24 V AC / DC (± 10 %)
Power consumption:	< 1.5 W / 24 V DC typical; < 2.9VA / 24 V AC typical; Peak current 200 mA
Sensor:	optical NDIR sensor (non-dispersive infra-red technology), with manual calibration (via zero button), <b>KCO2-SD</b> with automatic calibration (fixed) <b>KCO2-W</b> with automatic calibration (can be deactivated via DIP switches)
Measuring range:	<b>Multi-range switching</b> (selectable via DIP switches) 0...2000 ppm; 0...5000 ppm
Output:	<b>KCO2-SD</b> 0-10V (fixed) <b>KCO2-W</b> 0-10V or 4...20mA, working resistance < 800 Ω (selectable via DIP switches), with offset potentiometer (± 10 % of the measuring range)
Relay output:	<b>KCO2-SD</b> without changeover contact <b>KCO2-W</b> with potential-free <b>changeover contact</b> (24V / 1 A), switchpoint adjustable
Measuring accuracy:	typically ± 30 ppm ± 3 % of measured value
Temperature dependence:	± 5 ppm / °C or ± 0.5 % of measured value / °C (whichever is higher)
Pressure dependence:	± 0.13 % / mm Hg
Long-term stability:	< 2 % in 15 years
Gas exchange:	by diffusion
Warm up time:	approx. 1 hour
Ambient temperature:	-10...+60 °C
Response time:	approx. 1 minute, minimum flow rate 0.3 m/s (air)
Electrical connection:	0.14 - 1.5 mm <sup>2</sup> , via screw terminals
Housing:	plastic, UV-resistant, material polyamide, 30 % glass-globe reinforced, colour traffic white (similar to RAL 9016), housing cover for display is transparent! <b>KCO2-SD</b> with snap-on lid, <b>KCO2-W</b> with quick-locking screws (slotted / Phillips head combination)
Housing dimensions:	72 x 64 x 37.8 mm (Tyr 1/Tyr 01 without display) 72 x 64 x 43.3 mm (Tyr 1 with display)
Cable connection:	<b>cable gland</b> , plastic (M 16 x 1.5; with strain relief, exchangeable, max. inner diameter 10.4 mm) or <b>M12 connector</b> according to DIN EN 61076-2-101 (optional on request)
Protective tube:	<b>PLEUROFORM™</b> , material polyamide (PA6), with torsion protection, Ø 20 mm, NL = 202.5 mm, v <sub>max</sub> = 30 m/s (air)
Process connection:	via flange made of plastic (included in scope of delivery)
Protection class:	III (according to EN 60 730)
Protection type:	<b>KCO2-SD IP 54</b> (according to EN 60 529)* Housing tested, TÜV SÜD, Report No. 713160960A (Tyr 01) <b>KCO2-W IP 65</b> (according to EN 60 529)* Housing tested, TÜV SÜD, Report No. 713139052 (Tyr 1) * Housing in the built-in state (permeable PLEUROFORM: IP 30)
Standards:	CE conformity, electromagnetic compatibility according to EN 61 326, EMC Directive 2014 / 30 / EU
Optional:	<b>Display with illumination</b> , two line, cutout approx. 36x15 mm (W x H), for displaying the <b>Actual CO<sub>2</sub> content</b> and for setting the <b>switchpoint</b>
<b>ACCESSORIES</b>	See last chapter

**MFT-20-K**  
Mounting flange,  
plastic





S+S REGELTECHNIK

AERASGARD® **KCO2-W**  
AERASGARD® **KCO2-SD**

Duct CO2 sensors and measuring transducers,  
incl. mounting flange, self-calibrating, with multi-range switching  
and active / switching output



Dimensional drawing

KCO2 - W  
KCO2 - SD

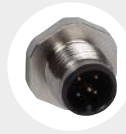
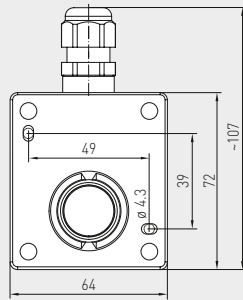

M12 connector  
(optional on request)

without display

with display

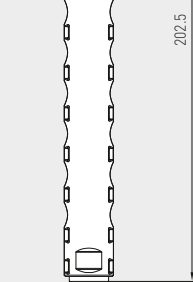
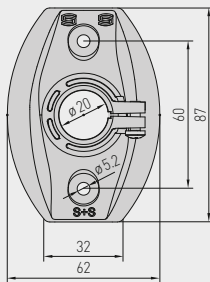
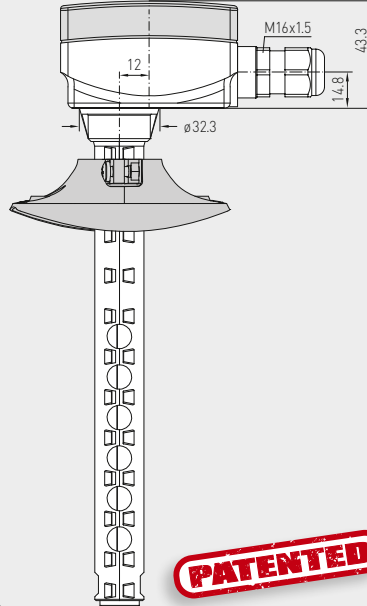
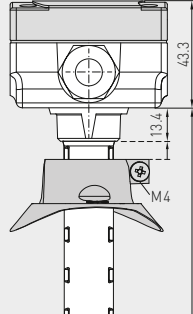
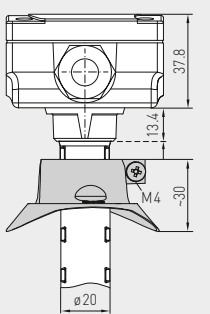

KCO2 - SD  
with snap-on lid  
(IP54)



KCO2 - W  
with quick-locking  
screws (IP65)



Mounting diagram

KCO2 - W  
KCO2 - SD

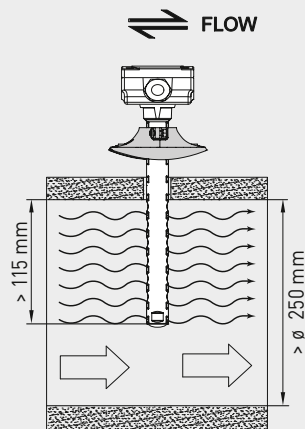

KCO2 - W  
with quick-locking  
screws and display (IP65)



Duct CO<sub>2</sub> sensors and measuring transducers,  
 incl. mounting flange, self-calibrating, with multi-range switching  
 and active / switching output

Schematic diagram **KCO2-W**

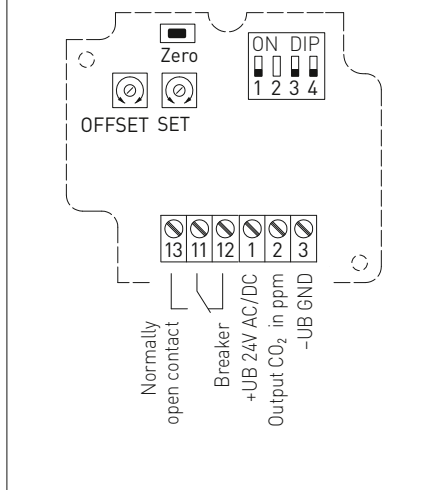

Schematic diagram **KCO2-SD**

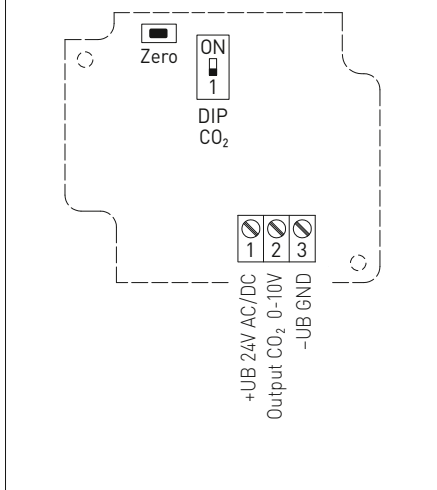

Connecting diagram **KCO2-W**

- 1 UB+ 24V AC/DC
  - 2 Output CO<sub>2</sub> 0-10V/4...20mA
  - 3 UB- GND
  - 12 Breaker
  - 11 Normally open contact
  - 13 Normally open contact
- changeover 24V/1A

Connecting diagram **KCO2-SD**

- 1 UB+ 24V AC/DC
- 2 Output CO<sub>2</sub> 0-10V in ppm
- 3 UB- GND

DIP switch **KCO2-W**

CO <sub>2</sub> content	DIP 1
0...2000 ppm (default)	OFF
0...5000 ppm	ON
CO <sub>2</sub> automatic zero point	DIP 3
deactivated	OFF
activated (default)	ON
Output	DIP 4
Voltage 0-10V (default)	OFF
Current 4...20 mA	ON

Note: **DIP 2** is not assigned!

DIP switch **KCO2-SD**

CO <sub>2</sub> content	DIP 1
0...2000 ppm (default)	OFF
0...5000 ppm	ON





KCO2-W  
with Display



AERASGARD® **KCO2-SD** Duct CO2 sensors and measuring transducers, *Standard*  
AERASGARD® **KCO2-W** Duct CO2 sensors and measuring transducers, *Premium*

Type / WG02	Measuring Range CO2	Output CO2	Equipment	Display	Item No.	Price
<b>KCO2-SD</b>	(switchable)	(fixed)			<b>IP 54</b>	
KCO2-SD-U	0...2000 ppm / 0...5000 ppm	0-10 V	-		1501-3160-1001-200	<b>227,91 €</b>
<b>KCO2-W</b>	(switchable)	(switchable)			<b>IP 65</b>	
KCO2-W	0...2000 ppm / 0...5000 ppm	0-10 V / 4...20 mA	changeover contact		1501-3140-7301-200	<b>276,92 €</b>
KCO2-W <b>LCD</b>	0...2000 ppm / 0...5000 ppm	0-10 V / 4...20 mA	changeover contact, display	■	1501-3140-7321-200	<b>324,71 €</b>
Optional:	Cable connection with <b>M12 connector</b> according to DIN EN 61076-2-101 (on request)					
Note:	This unit <b>must not</b> be used as safety-relevant device!					



# AERASGARD® KLQ-CO2-W

## AERASGARD® KFTM-(LQ)-CO2-W / KTM-CO2-SD



S+S REGELTECHNIK

Multifunctional duct sensors and measuring transducers incl. mounting flange, for humidity, temperature, CO2 content and air quality (VOC), calibratable, with active/switching output

### Patented quality product (patent no. DE 10 2014 010 719.1)

Maintenance-free duct sensor **AERASGARD® KTM-CO2-SD** with active output, automatic calibration, in an impact-resistant plastic housing with quick-locking screws, for determining the CO2 content of the air (0...2000 ppm/0...5000 ppm) and the temperature (-35...+80 °C). The measuring transducer converts the measured values into a standard signal of 0-10V.

Maintenance-free duct sensor **AERASGARD® KFTM-LQ-CO2-W** with active/switching output, automatic calibration, in an impact-resistant plastic housing with quick-locking screws, optionally with/without Display, for determining the CO2 content of the air (0...2000 ppm/0...5000 ppm), the quality (0...100% VOC), the temperature (-35...+80 °C) as well as the relative air humidity (0...100% r.H.). The measuring transducer converts the measured values into a standard signal of 0-10V or 4...20 mA (switchable).

The sensor is used in offices, hotels, convention centres, apartments, shops, etc. for the purpose of evaluating the indoor climate. This enables energy-saving room ventilation on an as-needed basis, thereby reducing operating costs and improving well-being. One sensor for every 30 m² of room area is recommended.

A long-term stable, **digital humidity and temperature sensor** guarantees exact measurement results. The CO2 measurement is performed using an optical **NDIR sensor** (non-dispersive infra-red technology). The detection range is calibrated for standard applications such as monitoring residential rooms and conference rooms. The air quality is detected by a **VOC sensor** (mixed gas sensor for volatile organic substances). This sensor determines the loading of the room air due to contaminated gases such as cigarette smoke, body perspiration, exhaled breathing air, solvent vapours, emissions etc. With regard to the expected air contamination, low, medium or high VOC sensitivity can be selected. As an alternative, use IAQ categories (from excellent to unhealthy) following the guidelines of the German Federal Environmental Agency to assess the room air.

For more information, see the start of the chapter.

### TECHNICAL DATA

Voltage supply:	24 V AC / DC (± 10%)
Power consumption:	< 4.8 W / 24 V DC typical; < 6.8 VA / 24 V AC typical; peak current 200 mA
Outputs:	<b>KTM-CO2-SD</b> 0-10 V (fixed) <b>Kxx-CO2-W</b> 0-10 V or 4...20 mA, working resistance < 800 Ω (selectable via DIP switches, selected variant applies for all outputs), with offset potentiometer (± 10% of the measuring range)
Relay output:	<b>KTM-CO2-SD</b> without changeover contact <b>Kxx-CO2-W</b> with potential-free <b>changeover contact</b> (24 V / 1 A) (assignment selectable via DIP switches, switchpoint adjustable)

### HUMIDITY

Sensors:	<b>digital humidity sensor with integrated temperature sensor</b> , low hysteresis, high long-term stability
Sensor protection:	plastic sinter filter, Ø 16 mm, L = 35 mm, exchangeable (optional metal sinter filter, Ø 16 mm, L = 32 mm)
Measuring range, humidity:	0...100% r. H.
Operating range, humidity:	0...95% r. H. (without dew formation)
Deviation of humidity:	typically <b>± 2.0%</b> (20...80% r. H.) at +25 °C, otherwise ± 3.0%
Output, humidity:	0-10 V or 4...20 mA (selectable via DIP switches)

### TEMPERATURE

Measuring range, temperature:	-35...+80 °C
Operating range, temperature:	-10...+60 °C
Temperature deviation:	typically ± 0.2 K at +25 °C
Output, temperature:	<b>KTM-CO2-SD</b> 0-10 V (fixed) <b>Kxx-CO2-W</b> 0-10 V or 4...20 mA (selectable via DIP switches)

### AIR QUALITY (VOC)

Sensor, VOC:	VOC sensor (metal oxide) (VOC = volatile organic compounds), with manual calibration (using zero button) and automatic calibration (permanently active)
Measuring range, VOC:	0...100% air quality; referred to calibrating gas; <b>multi-range switching</b> (selectable via DIP switches) VOC sensitivities (low/medium/high) or IAQ category (Indoor Air Quality)
Output, VOC:	0-10 V (0 V = clean air, 10 V = polluted air) or 4...20 mA (selectable via DIP switches, switchpoint can be adjusted from 0...100% of the output signal)
Measuring accuracy, VOC:	typically ± 20% of final value (referred to calibrating gas)
Service life:	> 60 months (under normal load conditions) depending on the type of loading and gas concentration

### CARBON DIOXIDE (CO2)

Sensor, CO2:	<b>optical NDIR sensor</b> (non-dispersive infra-red technology), with manual calibration (via zero button), <b>KTM-CO2-SD</b> with automatic calibration (fixed) <b>Kxx-CO2-W</b> with automatic calibration (can be deactivated via DIP switches)
Measuring range, CO2:	0...2000 ppm or 0...5000 ppm (selectable via DIP switches)
Output, CO2:	<b>KTM-CO2-SD</b> 0-10 V (fixed) <b>Kxx-CO2-W</b> 0-10 V or 4...20 mA (selectable via DIP switches)
Measuring accuracy, CO2:	typically ± 30 ppm ± 3% of measured value
Temperature dependence, CO2:	± 5 ppm / °C or ± 0.5% of measured value / °C (whichever is higher)

continued on next page!

**SF-K**  
Plastic sinter filter (standard)



**SF-M**  
Metal sinter filter (optional)



**MFT-20-K**  
Mounting flange, plastic



Dimensional drawing

**MFT-20-K**

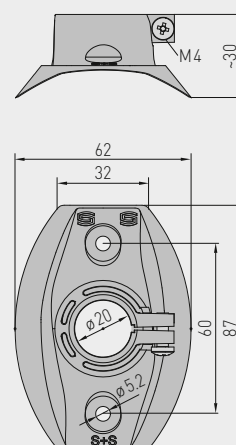



S+S REGELTECHNIK

# AERASGARD® KFTM - (LQ) - CO2 - W / KTM - CO2 - SD

Multifunctional duct sensors and measuring transducers incl. mounting flange, for humidity, temperature, CO2 content and air quality (VOC), calibratable, with active/switching output

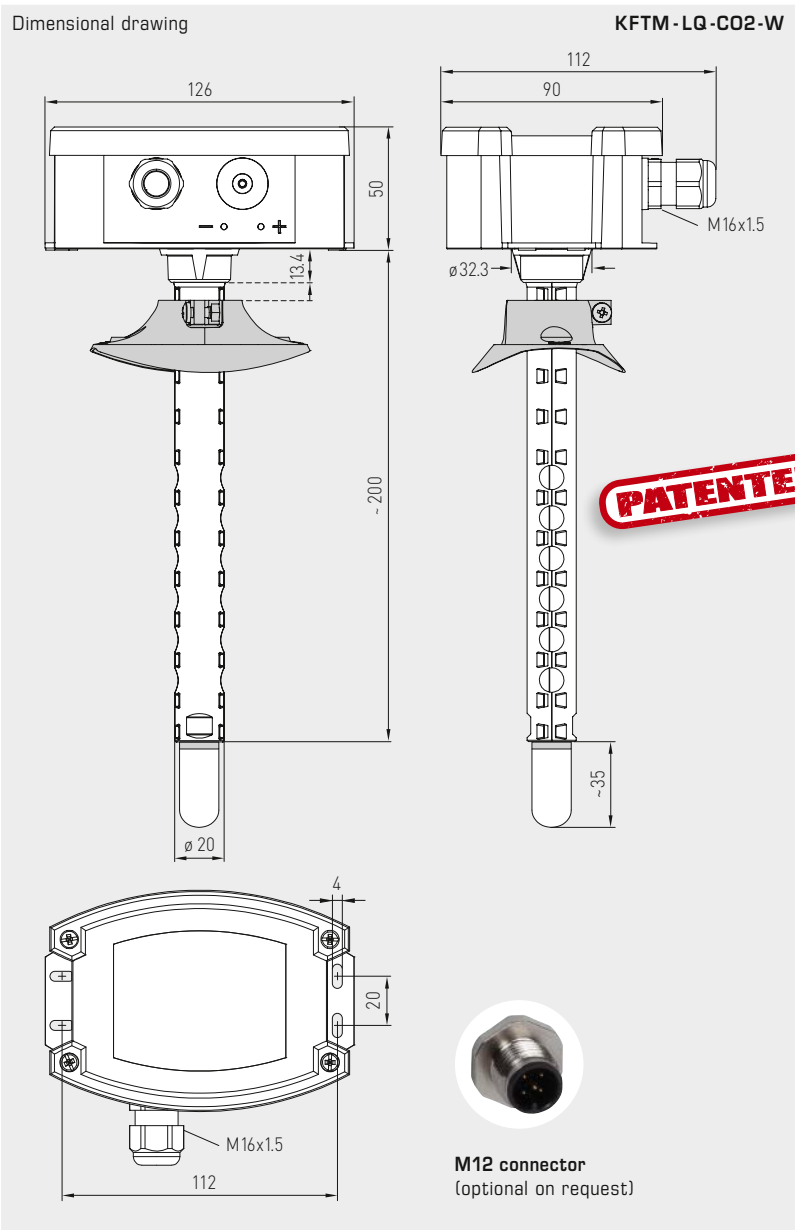

**KFTM - LQ - CO2 - W**  
with plastic sinter filter  
(standard)



**KFTM - LQ - CO2 - W**  
with display and  
plastic sinter filter  
(standard)

## TECHNICAL DATA (continued)

Pressure dependence:	± 0.13 % / mm Hg
Long-term stability:	< 2% in 15 years
Gas exchange:	by diffusion
Ambient temperature:	-10...+60 °C
Response time:	< 2 minutes, minimum flow rate 0.3 m/s (air)
Electrical connection:	0.14 - 1.5 mm <sup>2</sup> , via screw terminals
Housing:	plastic, UV-resistant, material polyamide (PA6), with torsion protection, 30% glass-globe reinforced, with quick-locking screws (slotted / Phillips head combination), colour traffic white (similar to RAL 9016), housing cover for display is transparent!
Housing dimensions:	126 x 90 x 50 mm (Tyr 2)
Cable connection:	<b>cable gland</b> , plastic (M 16 x 1.5; with strain relief, exchangeable, max. inner diameter 10.4 mm) or <b>M12 connector</b> according to DIN EN 61076-2-101 (optional on request)
Protective tube:	<b>PLEUROFORM™</b> , material polyamide (PA6), with torsion protection, Ø 20 mm, v <sub>max</sub> = 30 m/s (air) without filter: NL = 202.5 mm / with plastic filter: NL = 235 mm (optional with metal filter: NL = 227 mm)
Process connection:	via flange made of plastic (included in scope of delivery)
Protection class:	III (according to EN 60 730)
Protection type:	<b>IP 65</b> (according to EN 60 529) Housing in the built-in state (permeable PLEUROFORM: IP 30)
Standards:	CE conformity, electromagnetic compatibility according to EN 61 326, EMC Directive 2014/30/EU
Optional:	three-line <b>display with illumination</b> , cutout approx. 70 x 40 mm (W x H), for displaying actual humidity, actual temperature, air quality and/or the actual CO2 content



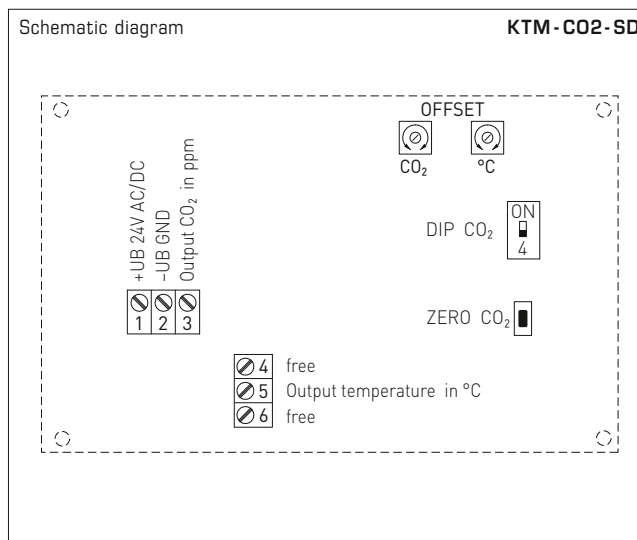
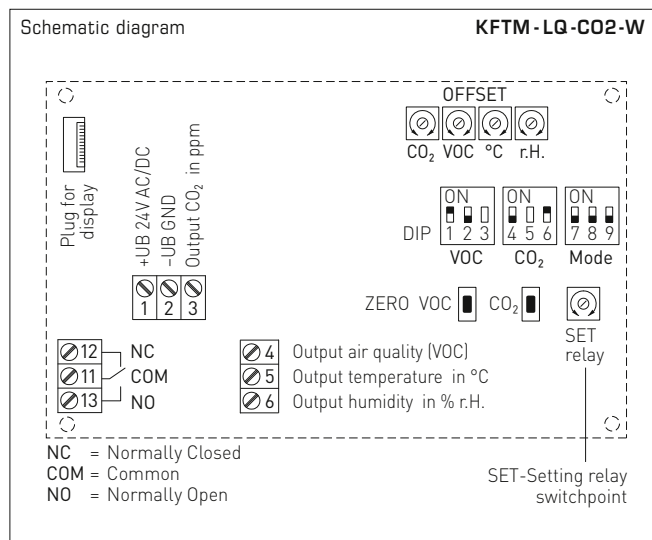

DIP switches	KFTM-LQ-CO2-W	
<b>VOC sensitivity</b>	DIP 1	DIP 2
LOW	OFF	OFF
MEDIUM (default)	ON	OFF
HIGH	OFF	ON
<b>IAQ (Indoor Air Quality)</b>	ON	ON
<b>CO2 content</b>	DIP 4	
0...2000 ppm (default)	OFF	
0...5000 ppm	ON	
<b>CO2 automatic zero point</b>	DIP 6	
deactivated	OFF	
activated (default)	ON	
<b>Relay assignment</b>	DIP 7	DIP 8
CO2 (default): 600...1900 ppm / 900...4700 ppm	OFF	OFF
VOC: 10...95%	ON	OFF
Temperature: -23...+74 °C	OFF	ON
Humidity: 10...95% r.H.	ON	ON
<b>Output</b>	DIP 9	
Voltage 0-10V (default)	OFF	
Current 4...20 mA	ON	
Note: DIP 3 and DIP 5 are not assigned!		

DIP switches	KTM-CO2-SD	
<b>CO2 content</b>	DIP 4	
0...2000 ppm (default)	OFF	
0...5000 ppm	ON	

Level	IAQ (Indoor Air Quality)	VOC
1	<b>excellent</b> no action required	0...19%
2	<b>good</b> prompt airing recommended	20...39%
3	<b>moderate</b> airing recommended	40...59%
4	<b>poor</b> increased airing required	60...79%
5	<b>unhealthy</b> intense airing necessary	80...100%

Table according to TVOC guidelines of the German Federal Environmental Agency to assess indoor air contamination  
 (Bundesgesundheitsbl - Gesundheitsforsch - Gesundheitsschutz 2007, 50: 990-1005)



S+S REGELTECHNIK

# AERASGARD® KLQ-CO2-W AERASGARD® KFTM-(LQ)-CO2-W / KTM-CO2-SD

Multifunctional duct sensors and measuring transducers incl. mounting flange, for humidity, temperature, CO2 content and air quality (VOC), calibratable, with active/switching output

KLQ-CO2-W  
KFTM-LQ-CO2-W  
with display



### Humidity table

MR: 0...100% r. H.

% r.H.	U <sub>A</sub> in V	I <sub>A</sub> in mA
0	0	4.0
5	0.5	4.8
10	1.0	5.6
15	1.5	6.4
20	2.0	7.2
25	2.5	8.0
30	3.0	8.8
35	3.5	9.6
40	4.0	10.4
45	4.5	11.2
50	5.0	12.0
55	5.5	12.8

Continued at the right ...

% r.H.	U <sub>A</sub> in V	I <sub>A</sub> in mA
60	6.0	13.6
65	6.5	14.4
70	7.0	15.2
75	7.5	16.0
80	8.0	16.8
85	8.5	17.6
90	9.0	18.4
95	9.5	19.2
100	10.0	20.0

### Temperature table

MR: -35...+80 °C

°C	U <sub>A</sub> in V	I <sub>A</sub> in mA
-35	0.0	4.0
-30	0.4	4.7
-25	0.9	5.4
-20	1.3	6.1
-15	1.7	6.8
-10	2.2	7.5
-5	2.6	8.2
0	3.0	8.9
+5	3.5	9.6
+10	3.9	10.3
+15	4.3	11.0
+20	4.8	11.7

Continued at the right ...

°C	U <sub>A</sub> in V	I <sub>A</sub> in mA
+25	5.2	12.3
+30	5.7	13.0
+35	6.1	13.7
+40	6.5	14.4
+45	7.0	15.1
+50	7.4	15.8
+55	7.8	16.5
+60	8.3	17.2
+65	8.7	17.9
+70	9.1	18.6
+75	9.6	19.3
+80	10.0	20.0



Multifunctional duct sensors and measuring transducers incl. mounting flange, for humidity, temperature, CO2 content and air quality (VOC), calibratable, with active/switching output

Dimensional drawing

KLQ-CO2-W

KLQ-CO2-W

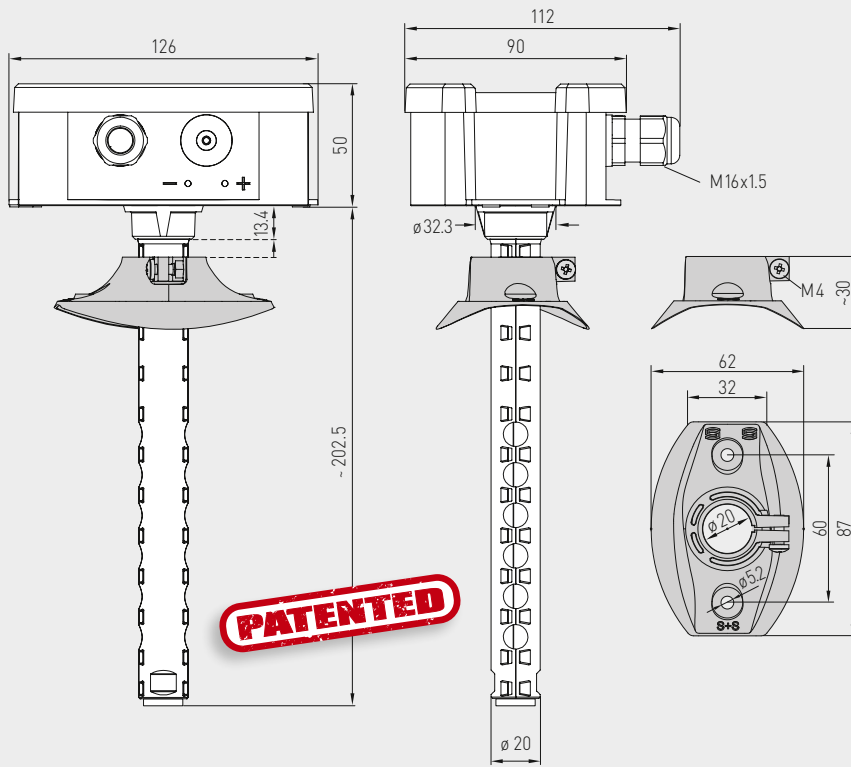

Dimensional drawing

KFTM-CO2-W  
KFTM-LQ-CO2-W  
KTM-CO2-SD

KFTM-CO2-W  
KFTM-LQ-CO2-W  
KTM-CO2-SD

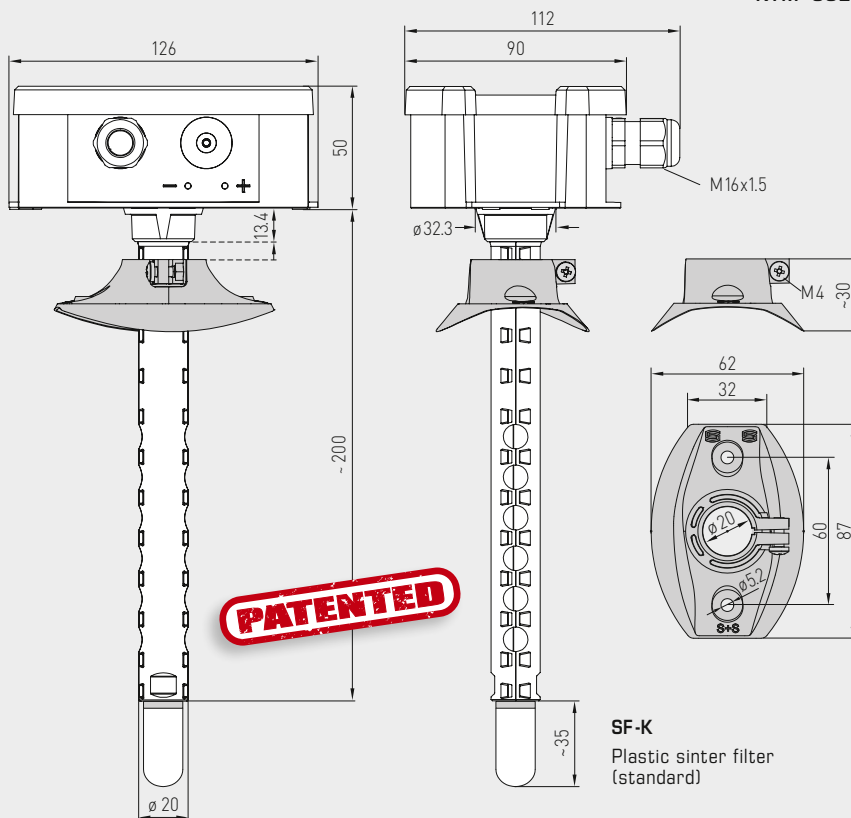

SF-M  
Metal sinter filter  
(optional)



SF-K  
Plastic sinter filter  
(standard)



S+S REGELTECHNIK

# AERASGARD® KLM - (LQ) - CO2 - W / KTM - CO2 - SD

Multifunctional duct sensors and measuring transducers incl. mounting flange, for humidity, temperature, CO2 content and air quality (VOC), calibratable, with active/switching output

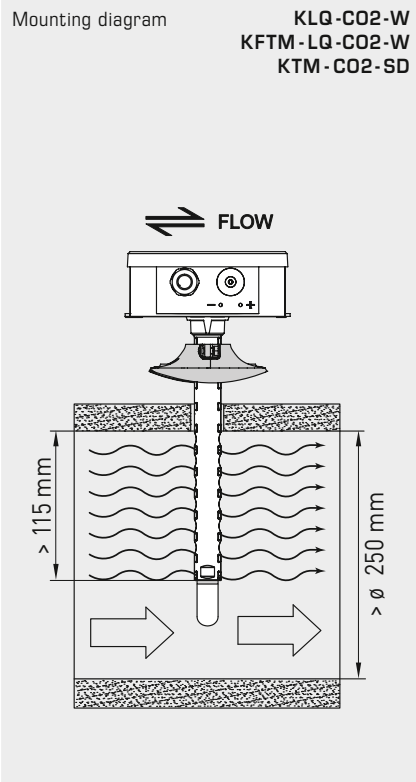

AERASGARD® KTM - CO2 - SD	Duct sensor for temperature and CO2 content, <i>Standard</i>
AERASGARD® KLQ - CO2 - W	Duct sensor for air quality (VOC) and CO2 content, <i>Premium</i>
AERASGARD® KFTM - CO2 - W	Multifunctional duct sensor for humidity, temperature and CO2 content, <i>Deluxe</i>
AERASGARD® KFTM - LQ - CO2 - W	Multifunctional duct sensor for humidity, temperature, air quality (VOC) and CO2 content, <i>Deluxe</i>

Type / WG02	Measuring Range	Humidity	Temperature	CO2	VOC	Equipment Display	Item No.	Price
<b>KTM - CO2 - SD</b>				(switchable)				
KTM-CO2-SD-U	-	-35...+80 °C	0...2000 / 5000 ppm	-	-	-	1501-8112-1001-200	<b>290,47 €</b>
<b>KLQ - CO2 - W</b>				(switchable)				
KLQ-CO2-W	-	-	0...2000 / 5000 ppm	0...100%	W	1501-8111-7301-500	<b>371,77 €</b>	
KLQ-CO2-W LCD	-	-	0...2000 / 5000 ppm	0...100%	W ■	1501-8111-7371-500	<b>427,95 €</b>	
<b>KFTM - CO2 - W</b>				(switchable)				
KFTM-CO2-W	0...100% r.H.	-35...+80 °C	0...2000 / 5000 ppm	-	W	1501-8116-7301-200	<b>355,23 €</b>	
KFTM-CO2-W LCD	0...100% r.H.	-35...+80 °C	0...2000 / 5000 ppm	-	W ■	1501-8116-7371-200	<b>389,38 €</b>	
<b>KFTM - LQ - CO2 - W</b>				(switchable)				
KFTM-LQ-CO2-W	0...100% r.H.	-35...+80 °C	0...2000 / 5000 ppm	0...100%	W	1501-8118-7301-500	<b>445,56 €</b>	
KFTM-LQ-CO2-W LCD	0...100% r.H.	-35...+80 °C	0...2000 / 5000 ppm	0...100%	W ■	1501-8118-7371-500	<b>501,75 €</b>	
Outputs:	<b>0-10V or 4...20 mA</b> (selectable via DIP switches, selected variant applies for all outputs) – <i>Standard</i> duct sensor <b>KTM - CO2 - SD</b> with fixed output 0-10V!							
Equipment:	<b>W = changeover contact</b> – <i>Standard</i> duct sensor <b>KTM - CO2 - SD</b> without changeover contact!							
Optional:	Cable connection with <b>M12 connector</b> according to DIN EN 61076-2-101 (on request)							
Note:	This unit <b>must not</b> be used as safety-relevant device!							

ACCESSORIES			
<b>SF-M</b>	Metal sinter filter, Ø 16 mm, L = 32 mm, exchangeable stainless steel <b>V4A</b> (1.4404)	7000-0050-2200-100	<b>40,31 €</b>

Duct airflow monitors,  
including mounting flange, electronic, one-step and two-step,  
with active/switching output

Electronic duct air flow sensor **RHEASGARD® KLGf** with active output, in an impact-resistant plastic housing, optionally with/without display, for determining the flow velocity in m/s. The measuring transducer converts the measurement signal into a standard signal of 0 - 10 V.

Electronic duct air flow monitor **RHEASREG® KLSW** with switching output (relay one-step or two-step), in a plastic housing, for determining the flow velocity in m/s. Fine adjustment of the measuring range end value by the user is possible with the help of a potentiometer.

The flow sensors are suitable for monitoring or controlling airflows in ducts, at ventilators and dampers, for flow-dependent monitoring of humidifiers and electric heating registers according to DIN 57100, part 420, or for use in connection with DDC systems.

**TECHNICAL DATA**

Power supply:	24 V AC / DC or 230V AC +5/-13%, 50...60 Hz	
Output:	1 or 2 potential-free relays (changeover contacts), 8 A, max. 2 kW or 0 - 10V (relative, linearised on request), see table	
Current consumption:	approx. 3 VA	
	<b>KLGf-1, KLSW-3, KLSW-4</b>	<b>KLSW-6</b>
Measuring range:	0.1...30 m/s	0.1...15 m/s
Sensitivity:	0.1...30 m/s (adjustable)	0.1...15 m/s (adjustable)
Switching hysteresis:	2% (permanently set)	approx. 1...10% (adjustable)
Start bridging:	-	approx. 15...120 s (adjustable)
Switch-off delay:	-	approx. 2...20 s (adjustable)
Connection cable:	max. 50 m at minimum cross section 1.5 mm <sup>2</sup> per conductor; avoid laying parallel with mains voltage-carrying lines, or use shielded cables, apply cable screen one-sided	
Ambient temperature:	0...+60 °C at the device; 0...+80 °C medium	
Medium:	pollutant-free, non-precipitating air	
Sensors:	calorimetric, sensor breakage protection, temperature-compensated	
Housing:	plastic, UV-resistant, material polyamide, 30% glass-globe reinforced, colour traffic white (similar to RAL 9016)	
	<b>KLSW-xx, KLGf-1 with display:</b> 108 x 70 x 73.5 mm (Thor 2)	
	<b>KLGf-1 without display:</b> 72 x 64 x 37.8 mm (Tyr 1), with quick-locking screws (slotted / Phillips head combination)	
Cable connection:	<b>cable gland</b> , plastic (M 16 x 1.5; with strain relief, exchangeable, inner diameter 10.4 mm)	
Protective tube:	metal (brass, nickel-plated), Ø 10 mm, nominal length NL = 140 mm	
Process connection:	by mounting flange (included in the scope of delivery)	
Electrical connection:	0.25 - 2.5 mm <sup>2</sup> , via screw terminals	
Protection class:	II (according to EN 60 730) at KLSW 3 (UB = 230 V AC) III (according to EN 60 730) at UB = 24 V	
Protection type:	<b>IP 65</b> (according to EN 60 529)	
Standards:	CE conformity, EMC directive 2014 / 30 / EU, low-voltage directive 2014 / 35 / EU	

KLSW-xx



KLGf-1  
with display

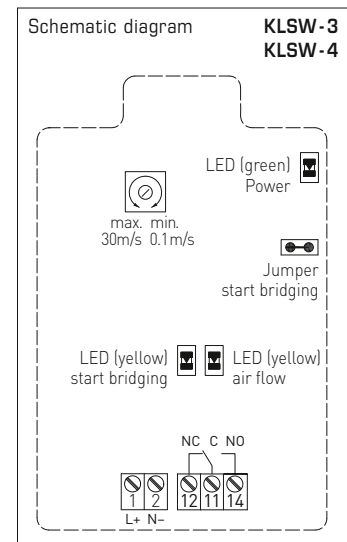
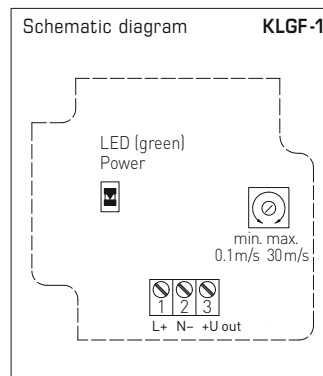
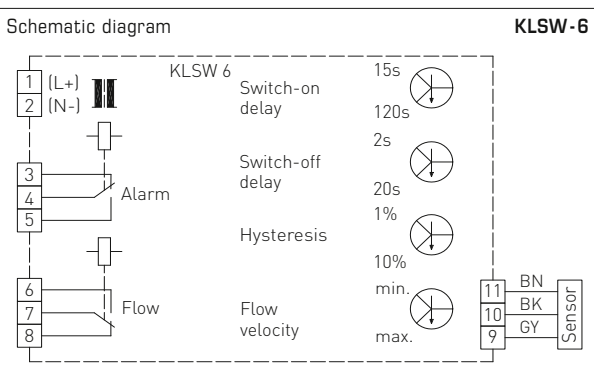



S+S REGELTECHNIK

RHEASGARD® KLGf  
RHEASREG® KLSW

Duct airflow monitors,  
including mounting flange, electronic, one-step and two-step,  
with active/switching output

Dimensional drawing

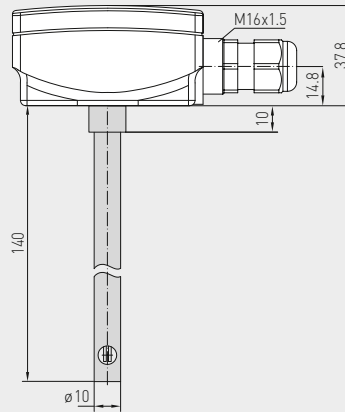
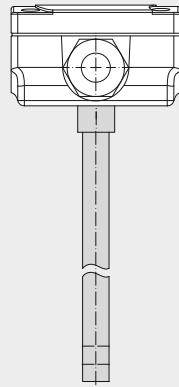
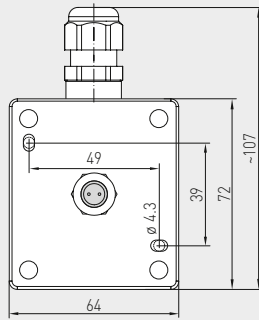

KLGf-1 without display  
(compact)

KLGf-1  
without display  
(compact)



Dimensional drawing

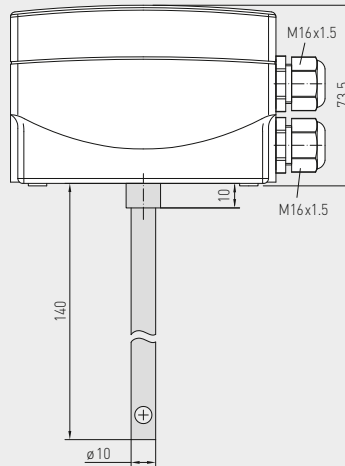
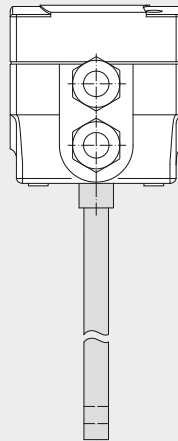
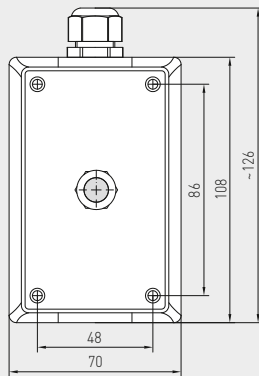

KLSW-xx  
KLGf-1 with display

Dimensional drawing

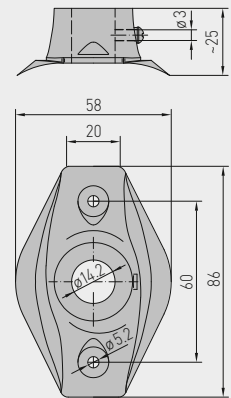

MF-14-K

RHEASGARD® KLGf Duct airflow monitors  
RHEASREG® KLSW Duct airflow monitors, one-step and two-step

Type / WG01	Relay (Steps)	Power-Supply	Output	Display	Item No.	Price
<b>KLGf</b>						
KLGf 1	–	24 V AC / DC	0-10 V (relative)		1701-3120-1000-000	<b>263,10 €</b>
KLGf 1_Display	–	24 V DC	0-10 V (linearised)	■	on request	
<b>KLSW</b>						
<b>one-step</b>						
KLSW 3	1	230 V AC	1 x Changeover contact		1701-3011-0001-000	<b>195,19 €</b>
KLSW 4	1	24 V AC / DC	1 x Changeover contact		1701-3021-0000-000	<b>195,19 €</b>
<b>KLSW</b>						
<b>two-step</b>						
KLSW 6	2	24 V AC / DC	2 x Changeover contact		1701-3022-0000-000	<b>246,12 €</b>
Note:	<b>KLSW 6</b> is supplied as standard with a <b>manual reset button!</b> <b>Automatic reset</b> (without reset button)					on request
<b>ACCESSORIES</b>				<b>Tube Gland</b>		
<b>MF-14-K</b>	<b>Mounting flange</b> , plastic (included in the scope of delivery)			Ø 14.2 mm	7100-0030-2000-000	<b>9,10 €</b>
<b>MF-10-K</b>	<b>Mounting flange</b> , plastic			Ø 10.2 mm	7100-0031-1000-000	<b>9,10 €</b>
For further information see last chapter!						

**Vane switch, mechanical, with paddle,  
with switching output**

WFS

Mechanical wind vane switch **RHEASREG® WFS** with switching output, in an impact-resistant plastic housing, with stainless-steel paddle, for flow monitoring of gaseous, non-aggressive media.

The flow sensor is used as a flow controller or air flow monitor in air conditioning ducts, in air intake or exhaust devices of ventilators or electric heating registers (also for contaminated, oily air).



**TECHNICAL DATA**

Switching capacity: (Contact load)	15 (8) A; 24...250 V AC at 24 V AC min. 150 mA
Contact:	dustproof microswitch as single-pole, potential-free changeover contact
Housing:	plastic, UV-resistant, material polyamide, 30 % glass-globe reinforced, colour traffic white (similar to RAL 9016)
Housing dimensions:	108 x 70 x 73.5 mm (Thor 2)
Base body:	galvanised steel
Moving arm:	brass
Vane:	stainless steel <b>V2A</b> (1.4301)
Cable connection:	<b>cable gland</b> , plastic (M20 x 1.5; with strain relief, exchangeable, inner diameter 8 - 13 mm)
Housing temperature:	-40...+85 °C
Operating difference:	≥ 1 m / s
Electrical connection:	0.14 - 1.5 mm <sup>2</sup> , via screw terminals
Protection class:	I (according to EN 60 730)
Protection type:	<b>IP 65</b> (according to EN 60 529)
Standards:	CE conformity, EMC directive 2014 / 30 / EU, low-voltage directive 2014 / 35 / EU

**FUNCTION**

Monitor:	Contact 1 - 3 breaks when flow rate drops to the preset value. Simultaneously, contact 1 - 2 closes and can be used as signal contact. Device is factory-set to the minimum switch-off value, which can be increased by turning the range adjusting screw clockwise.
Installation:	vertical in horizontal air ducts. Min. smoothing distance = 5 x duct diameter upstream and downstream of vane. For airspeeds > 5 m / s, vane is to be trimmed at the marked spots. Thereby the minimum switch-off value increases to approx. 2.5 m / s and the minimum switch-on value to approx. 4 m / s.

Connecting diagram

WFS

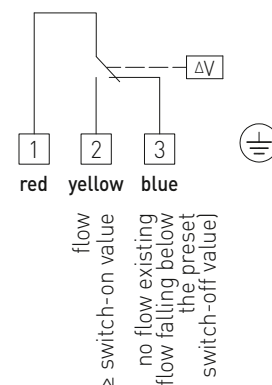



Dimensional drawing

WFS

WFS

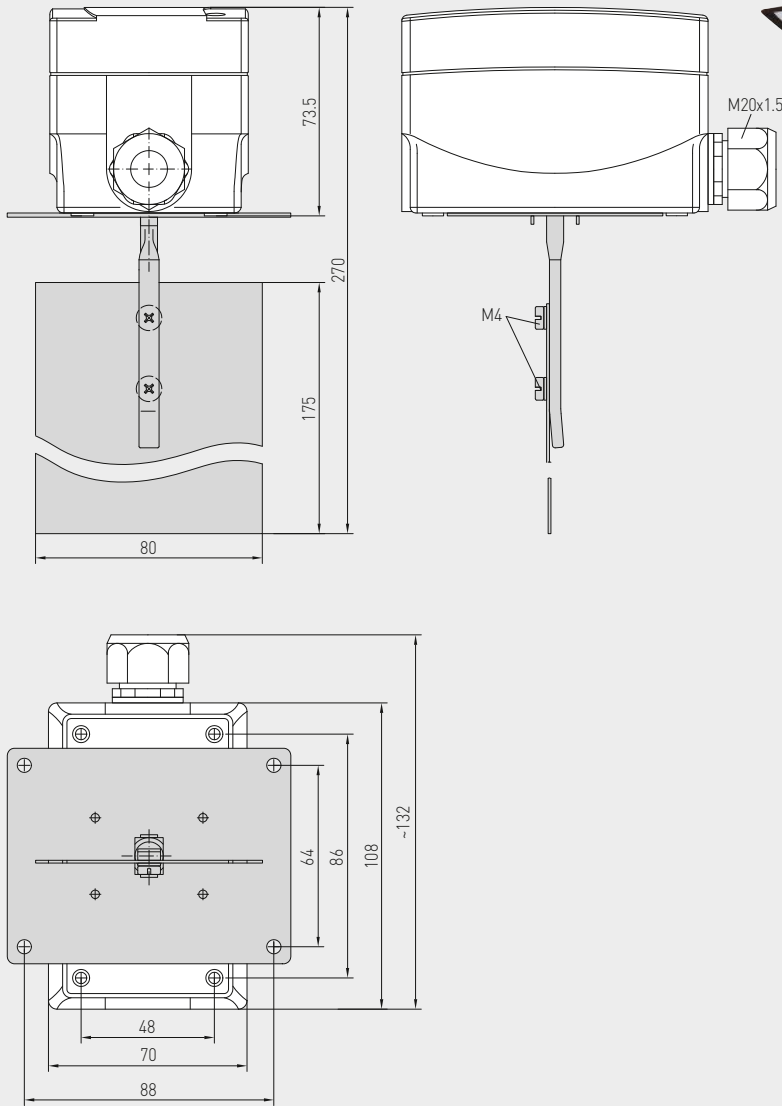

**RHEASREG® WFS** Vane switch, mechanical, with paddle

Type / WG01	Switch-on value		Switch-off value		Item No.	Price
	min.	max.	min.	max.		
<b>WFS</b>						
WFS-1E	2.5 m/s	9.2 m/s	1 m/s	8 m/s	1702-3020-0000-000	<b>76,78 €</b>
<b>Spare part</b>						
<b>PWFS-08</b>	Spare paddle for WFS (Stainless steel vane)				7700-0010-2000-000	<b>17,72 €</b>

**Flow monitors, mechanical, with paddle, with switching output**

SW

Mechanical paddle flow monitor **RHEASREG® SW** with switching output, in an impact-resistant plastic housing, with stainless-steel paddle, for flow monitoring of liquid and gaseous, non-aggressive media in pipes, hydraulic systems of 3/4" through 1/2" to 8" diameter.

The flow sensor is used as a flow controller or low water alarm, e.g. for pumps in oil and cooling circuits, cooling systems, evaporators, compressors and heat exchangers, with brass or stainless-steel bodies.

**TECHNICAL DATA**

Switching capacity:	15 (8) A; 24...250 V AC, at 24 V AC min. 150mA
Contact:	dustproof microswitch as potential-free single-pole changeover contact
Housing:	plastic, UV-resistant, material polyamide, 30% glass-globe reinforced, colour traffic white (similar to RAL 9016)
Housing dimensions:	108 x 70 x 73.5 mm (Thor2)
Base body:	galvanised steel
Screwed socket:	brass or stainless steel (see table)
Paddle:	stainless steel <b>V4A</b> (1.4401)
Cable connection:	<b>cable gland</b> , plastic (M20 x 1.5; with strain relief, exchangeable, inner diameter 8 - 13 mm)
Housing temperature:	-40...+85 °C
Max. temperature of medium:	+120 °C
Electrical connection:	0.14 - 1.5 mm <sup>2</sup> , via screw terminals
Protection class:	I (according to EN 60 730)
Protection type:	IP 65 (according to EN 60 529)
Standards:	CE conformity, EMC directive 2014/30/EU, low-voltage directive 2014/35/EU

**FUNCTION**

Monitor:	Contact COM-NO (red - yellow) breaks when flow rate drops to the preset value. Simultaneously, contact COM-NC (red - blue) closes and can be used as signal contact. Device is factory-set to the minimum switch-off value, which can be increased by turning the range adjusting screw clockwise.
Installation:	vertical in horizontal pipes, tee R x" according to DIN 2950, min. smoothing distance = 5 x pipe diameter upstream and downstream of paddle

**Table of switching values**

Pipe Ø DN in inches	Factory Setting OFF / ON (m <sup>3</sup> /h)	Max. Setting OFF / ON (m <sup>3</sup> /h)
<b>SW-1 / SW-2</b>		
1"	0.6 / 1.0	2.0 / 2.1
1 1/4"	0.8 / 1.3	2.8 / 3.0
1 1/2"	1.1 / 1.7	3.7 / 4.0
2"	2.2 / 3.1	5.7 / 6.1
2 1/2"	2.7 / 4.0	6.5 / 7.0
3"	4.3 / 6.2	10.7 / 11.4
4"	11.4 / 14.7	27.7 / 29.0
4" Z	6.1 / 8.0	17.3 / 18.4
5"	22.9 / 28.4	53.3 / 55.6
5" Z	9.3 / 12.9	25.2 / 26.8
6"	35.9 / 43.1	81.7 / 85.1
6" Z	12.3 / 16.8	30.6 / 32.7
8"	72.6 / 85.1	165.7 / 172.5
8" Z	38.6 / 46.5	90.8 / 94.2
<b>SW-3 / SW-4</b>		
1/2"	0.174 / 0.48	0.846 / 0.948
3/4"	0.138 / 0.408	0.768 / 0.858



**SW-3E  
SW-4E**

Incl. attached Tee Fitting according to DIN 2950

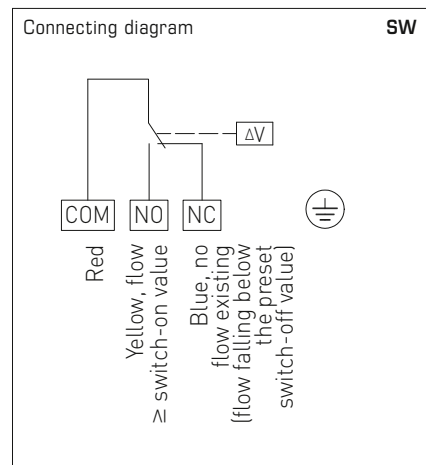

Dimensional drawing

SW  
PSW-09

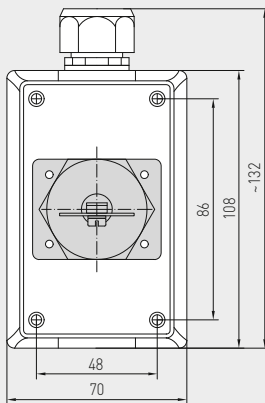
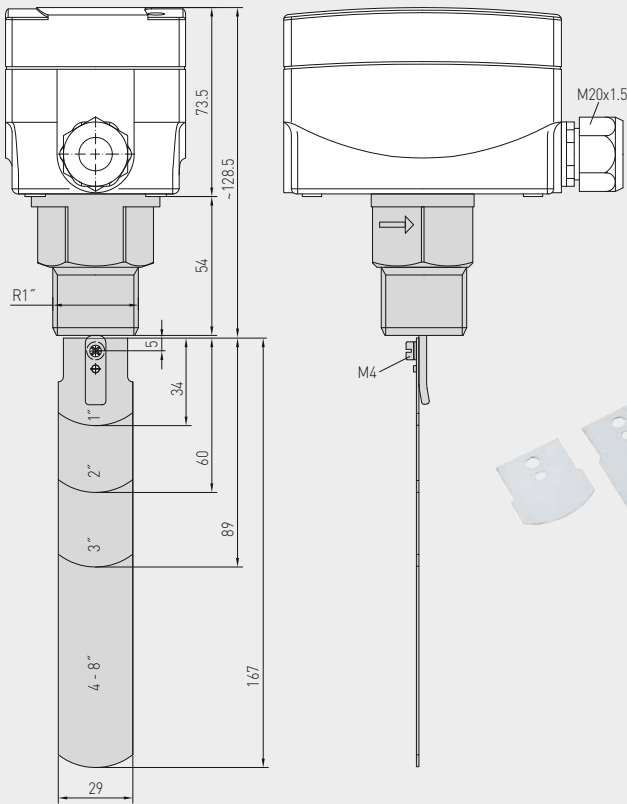

**PSW-09**  
Set of stainless steel  
paddles (Spare part)

Pipe diameters with paddle combinations

Pipe Ø DN	in inches	in mm	Paddle combination PSW-09
1/2"		15 mm	1
3/4"		20 mm	1
1"		25 mm	1
1 1/4"		32 mm	1
1 1/2"		40 mm	1
2"		50 mm	1, 2
2 1/2"		65 mm	1, 2
3"		80 mm	1, 2, 3
4" Z		100 mm	1, 2, 3 plus 4 (shorten to 92 mm)
5" Z		125 mm	1, 2, 3 plus 4 (shorten to 117 mm)
6" Z		150 mm	1, 2, 3 plus 4 (shorten to 143 mm)
7 - 8" Z		200 mm	1, 2, 3 plus 4 (unshortened)

RHEASREG® SW Flow monitors, mechanical, with paddle

Type/ WG01	Pipe Ø DN	Max. Operating Pressure PN max	Medium	(Contacting Parts Made of)	Incl. attached Tee Fitting according to DIN 2950	Item No.	Price	
<b>SW</b>								
SW-1E	1" - 8"	11 bar	normal	(brass)	-	1702-3011-0000-000	110,66 €	
SW-2E	1" - 8"	30 bar	aggressive	(stainless steel V4A)	-	1702-3012-0101-000	350,04 €	
SW-3E	1/2"	11 bar	normal	(brass)		1702-3013-0031-000	203,85 €	
SW-4E	3/4"	11 bar	normal	(brass)		1702-3014-0041-000	203,85 €	
<b>Spare part</b>								
PSW-09	Set of stainless steel paddles 1-8" (4 pieces)						7700-0010-1000-000	18,30 €
Note: Z = Fourth paddle included in the scope of delivery to be used in addition to the three paddles already factory-mounted (1, 2, 3 plus 4)!								



## Radio Sensors

**KYMASGARD®**, the radio transmission range of our product lines, helps you achieve significant savings. Without additional energy costs, these devices minimize your wiring needs and provide cost savings even at the very installation level.

**KYMASGARD®** combines appealing aesthetics with a host of application possibilities. A thoroughly clever solution!

### APPLICATION RANGE

- > Reconstruction of facilities
- > Modernization and extension of offices, hotels and residential buildings
- > Listed, historical and sacred buildings under monumental protection
- > Schools, museums and hospitals
- > Industrial buildings and administration centers



## KYMASGARD®

606 – 633

### EnOcean radio transmitter KYMASGARD® 9000

<b>RFTM-xx-FSE</b>	Multifunctional room radio sensor for humidity, temperature, air quality (VOC), and motion/presence	<b>613</b>
--------------------	---	------------

### EnOcean radio transmitters

<b>RTF2-FSE</b>	Room temperature radio sensor	<b>614</b>
<b>RFTF2-FSE</b>	Room humidity and temperature radio sensor	<b>614</b>
<b>RTF2-FSE-P</b>	Room temperature radio sensor	<b>615</b>
<b>RFTF2-FSE-P</b>	Room humidity and temperature radio sensor	<b>615</b>
<b>RTF2-FSE-PT</b>	Room temperature radio sensor	<b>616</b>
<b>RFTF2-FSE-PT</b>	Room humidity and temperature radio sensor	<b>616</b>
<b>RTF2-FSE-PD</b>	Room temperature radio sensor	<b>617</b>
<b>RFTF2-FSE-PD</b>	Room humidity and temperature radio sensor	<b>617</b>
<b>RTF2-FSE-PDT</b>	Room temperature radio sensor	<b>618</b>
<b>WT-FSE</b>	Wall pushbutton	<b>619</b>
<b>FK-1-FSE</b>	Door and window contact unit	<b>621</b>
<b>HT4-FSE</b>	Hand-held remote control unit	<b>620</b>
<b>IN400-FSE-UP</b>	Pushbutton interface, in-wall	<b>628</b>
<b>AFTF-HK-FSE</b>	Multifunctional outside radio sensor for humidity, temperatures and light intensity	<b>632</b>
<b>AWFS-HK-FSE</b>	Multifunctional outside radio sensor for wind strength and light intensity	<b>633</b>

### EnOcean radio receiver / actuators, in-wall

<b>JA100-FEM-UP</b>	Venetian blind actuator, in-wall	<b>623</b>
<b>SA100-FEM-UP</b>	Switching actuator, in-wall	<b>624</b>
<b>SA200-FEM-UP</b>	Switching actuator, in-wall	<b>625</b>
<b>TA100-FEM-UP</b>	Thermostat actuator, in-wall	<b>626</b>
<b>TA200-FEM-UP</b>	Thermostat actuator, in-wall	<b>627</b>

### EnOcean radio receiver / actuators, on-wall

<b>JA200-FEM-AP</b>	Venetian blind actuator, on-wall	<b>629</b>
<b>SA400-FEM-AP</b>	Switching actuator, on-wall	<b>630</b>
<b>SV600-FEM-AP</b>	Dimmer actuator, on-wall	<b>631</b>

### EnOcean communication

<b>USB-FEM</b>	USB communication flash drive	<b>611</b>
----------------	-------------------------------	------------

### EnOcean Gateway

<b>GW-RS485-FEM</b>	Gateway for RS485 bus	<b>622</b>
---------------------	-----------------------	------------





# Radio Sensors



## KYMASGARD® – Intelligent radio sensor equipment for multifunctional requirements

### Broad Spectrum

Our product line for wireless radio installations using EnOcean technology are designed to be multifunctional. This reduces the diversity of types and expands their possible applications. Thanks to microprocessor technology, almost any measuring range can be represented, including custom specifications. The bus addresses are adjustable via DIP switches.

### Optimum Precision

All devices are developed, manufactured and tested according to the latest criteria. Each sensor is precisely re-adjustable using offset potentiometers. Take advantage of our experience, our development, manufacturing and product know-how and order these products directly from the manufacturer.



**enocean®**



### Approved Safety



RoHS conforming materials



ESD compliant manufacturing



CE compliance tested by external laboratories

### Certified Quality



Our development and production in Nuremberg/Germany is certified by TÜV Thüringen according to DIN EN ISO 9001:2015.



GOST certificates



EAC certified

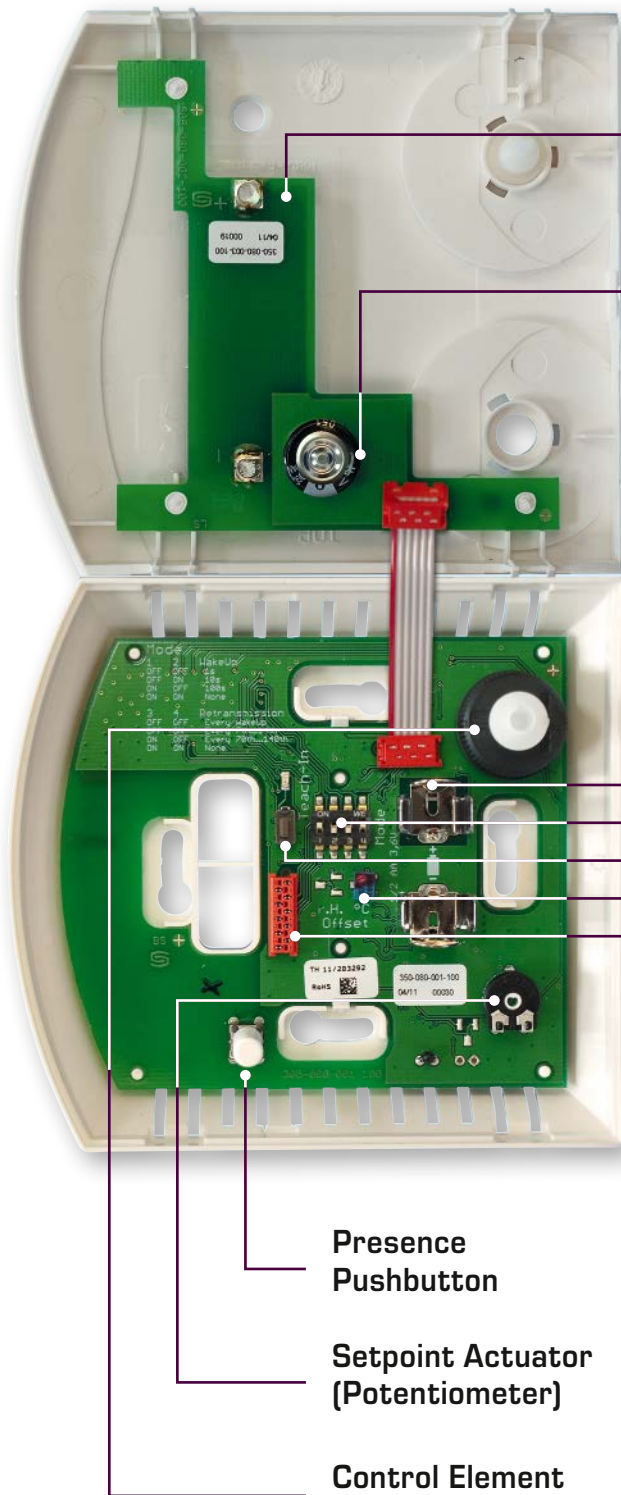

**Extra-large Solar Cell**

With solar generator for energy supply, battery-free, maintenance-free

**Goldcap**

For energy store (internal)

**Optional Battery Operation**

Change-over to lithium cell based energy supply at times of poor ambient light

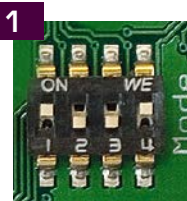

**DIP Switches**

For multi-range switching and setting of measuring and transmission cycle

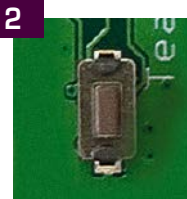

**Teach-In**

For teaching the sensor and establishing connection between transmitter and receiver

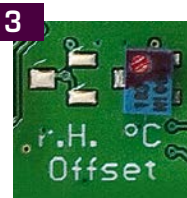

**Offset Potentiometer**

For fine adjustment (zero point offset) and readjustment upon recalibration

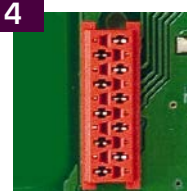

**Quality Assurance**

Calibration and balancing are done by means of the bus system

**Presence Pushbutton**

**Setpoint Actuator (Potentiometer)**

**Control Element (Rotary Switch)**



CONTROLLERS / ACTUATORS / GATEWAYS

	SA400-FEM-AP	JA200-FEM-AP	SV600-FEM-AP	IN400-FSE-UP	SA100-FEM-UP	SA200-FEM-UP	TA100-FEM-UP	TA200-FEM-UP	JA100-FEM-UP	GW-RS485-FEM	USB - FEM
<b>KYMASGARD® 9000 system</b>											
RFTM-FSE						●	●	●		●	●
RFTM-FSE-ST						●	●	●		●	●
RFTM-VOC-FSE										●	●
RFTM-BW-FSE	●		●		●	●	●	●		●	●
<b>Frija ROOM CONTROL UNITS</b>											
RTF2 - FSE										●	●
RFTF2 - FSE										●	●
RTF2 - FSE - P			●				●	●		●	●
RFTF2 - FSE - P										●	●
RTF2 - FSE - PT										●	●
RFTF2 - FSE - PT										●	●
RTF2 - FSE - PD2										●	●
RTF2 - FSE - PD5										●	●
RFTF2 - FSE - PD2										●	●
RTF2 - FSE - PD5T										●	●
<b>WINDOW CONTACT</b>											
FK - FSE - xx	●	●	●		●	●			●	●	●
<b>WALL PUSHBUTTON</b>											
WT - FSE - xx	●		●				●	●		●	●
WT - FSE - O xx	●						●	●		●	●
WT - FSE - V xx		●							●	●	●
<b>MANUAL PUSHBUTTON</b>											
HT - FSE - xx	●	●	●		●	●	●	●	●	●	●
<b>OUTSIDE SENSOR</b>											
AFTF-HK-FSE										●	●
AWSF-HK-FSE		●							●	●	●

● = optimum compatibility



USB-FEM

Communication USB flash drive with protocol on EnOcean basis for showing the active radio communication subscribers. The addresses of all registered radio communication subscribers are displayed. It is used for checking the field intensity and the transmitted data.

**TECHNICAL DATA**

Operation:	connection via USB port at the PC
Radio technology:	EnOcean protocol, transmission power max. 10 mW
Radio transmitter module:	TCM 300
Communication:	ESP 3 protocol for communication between USB-FEM and application software like EnOcean-Analyse-Software (software included in the scope of delivery)
Range of coverage:	indoors typically 30 - 100m, outdoors up to 300m
Dimensions:	71 x 23 x 11 mm
Housing:	plastic, material ABS, transparent
Ambient temperature:	0...+40°C
Humidity:	0...95% r.H., non-precipitating air
Scope of supply:	USB-FEM, USB flash drive with EnOcean-Analyse-Software

**FUNCTION**

With EnOcean-Analyse-Software installed, the necessary drivers are automatically installed as soon as the USB receiver is connected to the laptop.

The green LED shows that a USB connection exists. In the software, select the respective Com Port and click on Connect.

If the yellow LED is blinking, data is being received. Radio transmitters are recognized automatically (depending on the setting of the time interval, it may take several seconds until all transmitters have been recognized). Push the Learn button on the radio transmitter to display the EEP symbol in the corresponding ID number.

Double-click to transfer that radio transmitter to the workspace. Only radio transmitters that are in the workspace can be read out.



**KYMASGARD® USB - FEM** Communications USB flash drive

Type / WG02	Scope of supply	Item No.	Price
<b>USB-FEM</b>			
USB-FEM	USB-FEM, USB flash drive with EnOcean-Analyse-Software	1801-7460-7002-000	<b>303,10 €</b>
<b>Compatibility</b>	all KYMASGARD® radio transmitters and radio signal receivers		

**Multi-functional room radio sensors / room control units with solar cell for temperature, humidity, air quality (VOC) and motion / presence**

**Radio bus system KYMASGARD® 9000**

The room radio sensors of the radio bus system **KYMASGARD® 9000** are maintenance-free radio transmitters that operate without batteries (except for **RFTM-LQ-FSE**). Energy generation is effected by conversion of indoor room light into electric energy by means of a solar generator. If the ambient light is too low for power generation, the sensors can optionally be powered by two AAA batteries (not included). These sensors are used to detect the indoor climate and the setpoint values, and to transmit the recorded values to radio actuators and radio signal receivers / gateways via radio signals. The following device configurations are available:

The room sensor **KYMASGARD® RFTM-FSE** is used to measure room temperature and room humidity.

The room control unit **KYMASGARD® RFTM-FSE-ST** is used to measure room temperature and humidity, and to display and set the setpoint for temperature.

The setpoint is set directly on site using touch buttons.

The room sensor **KYMASGARD® RFTM-LQ-FSE** is used to measure room temperature, room humidity and air quality (VOC = Volatile Organic Compounds).

The room sensor **KYMASGARD® RFTM-BW-FSE** is used to measure room temperature, room humidity and the movement (or presence) of persons.

Optional accessories include the wall holder **WH-3100** and the stand holder **SH-3110**, which enable them to be used as table-top units.

Room devices (Ø 90 mm) with stand holder (optional)



**TECHNICAL DATA**

Operation:	Power generated by solar cell, battery-free, (except for <b>RFTM-LQ-FSE</b> ) maintenance-free (battery operation optional)
Radio technology:	EnOcean protocol, modulation ASK, 868 MHz, transmission power max. 10 mW, telegram type 4BS
Channels:	1 temperature, 1 humidity, 1 setpoint, 1 air quality (VOC), 1 motion/presence
Radio transmitter module:	EnOcean Dolphin
Measurand acquisition:	adjustable, every 1s / 10s / 100s
Transmission interval:	adjustable, typically every 100 seconds, or at any measuring value change, status telegram approximately every 16 minutes
Range of coverage:	indoors typically 30 - 100 m, outdoors up to 300 m
Housing:	plastic, material: ABS, colour: pure white (similar to RAL 9010)
Dimensions:	Ø 88 mm, height 18 mm
Mounting:	Wall-mounted or free-standing using accessories
Ambient temperature:	-5...+55 °C
Storage temperature:	-25...+60 °C
Permitted humidity:	0...90% r.H., non-precipitating air
Protection class:	III (according to EN 60 730)
Protection type:	IP 30 (according to EN 60 529)
Standards:	CE conformity according to EMC Directive 2014 / 30 / EU and according to R&TTE Directive 2014 / 53 / EU

**SH-3110**  
Stand holder (optional)



**WH-3100**  
Wall holder (optional)



**HUMIDITY**

Operating range, humidity:	0...100% r. H.
Deviation in humidity:	typically ±2.0% (20...80% r. H.) at +25 °C, otherwise ±3.0%

**TEMPERATURE**

Operating range, temperature:	0...+40 °C
Deviation in temperature:	typically ±0.2K at +25 °C

**AIR QUALITY (VOC)**

VOC measuring range:	0...8000 ppb (Rotary switch position 0,1); with reference to calibration gas
VOC measuring accuracy:	±20% final value (with reference to the calibration gas)

**MOTION**

Detection:	yes/no (motion + presence)
------------	----------------------------

**SETPOINT / DISPLAY**

Operating elements:	The setpoint for temperature can be set and displayed on a touch panel.
---------------------	---







**RFTM - FSE - ST**  
Room control unit



**RFTM - FSE**  
**RFTM - LQ - FSE**  
Room radio sensors



**RFTM - BW - FSE**  
Room radio sensors



KYMASGARD® RFTM - FSE	Room radio sensor / room control unit for temperature and humidity
KYMASGARD® RFTM - LQ - FSE	Room radio sensor for temperature, humidity and air quality (VOC)
KYMASGARD® RFTM - BW - FSE	Room radio sensor for temperature, humidity and motion / presence detection

Type / WG02	Channels	Measuring ranges / detection		VOC	Movement	Set point	EnOcean-Profile	Item no.	Price
		Temperature	Humidity						
<b>RFTM - FSE</b>									
RFTM-FSE	2	0...+40 °C	0...100% r.H.	-	-	-	EEP A5-04-01	1801-4280-0000-000	260,04 €
RFTM-FSE ST	3	0...+40 °C	0...100% r.H.	-	-	●	EEP A5-10-12	1801-4280-0869-000	292,69 €
<b>RFTM - LQ - FSE</b>									
RFTM-LQ-FSE	4	0...+40 °C	0...100% r.H.	0...8000 ppb	-	-		1801-4280-3000-000	360,76 €
<b>RFTM - BW - FSE</b>									
RFTM-BW-FSE	3	0...+40 °C	0...100% r.H.	-	yes / no	-		1801-4280-4000-000	348,12 €
Equipment:	The <b>setpoint</b> for temperature can be set via the operating and display elements.								

ACCESSORIES			
<b>SH-3110</b>	<b>Stand holder</b> for room radio units (Ø 90 mm)	1801-8490-2000-000	29,35 €
<b>WH-3100</b>	<b>Wall holder</b> for room radio units (Ø 90 mm and Ø 130 mm)	1801-8490-1000-000	8,49 €
<b>Compatibility</b>	For an overview, see the start of the chapter		

**Wireless room humidity and temperature radio sensors with solar cell**

The room temperature sensors **KYMASGARD® RTF 2 - FSE** or **RFTF 2 - FSE** are batteryless and maintenance-free radio transmitters. Energy generation is effected by conversion of indoor room light into electric energy by means of a solar generator. These sensors are used to detect the room temperature or room humidity and to transmit the measurands via radio frequency to radio actuators and radio signal receivers / gateways. If ambient light conditions are insufficient for energy generation, they also can be operated on a lithium battery. To do so, insert the lithium cell into the battery holder provided. The device IDs are marked on a label in the device.

**RTF 2 - FSE**  
**RFTF 2 - FSE**



**TECHNICAL DATA**

Operation:	Energy generation by solar cell, batteryless, maintenance-free (optionally battery-operated)
Radio technology:	EnOcean protocol, modulation ASK, 868 MHz, transmission power max. 10 mW, telegram type 4BS
Channels:	1 temperature, 1 humidity
Radio transmitter module:	EnOcean Dolphin
Measuring range, temperature:	0...+40 °C
Deviation, temperature:	typically ±0.2K at +25 °C
Measuring range, humidity:	0...100 % r. H.
Deviation humidity:	typically ±3% r.H. (30... 80%) at +20 °C
Measurand acquisition:	adjustable, every 1s / 10 s / 100 s
Transmission interval:	adjustable, typically every 100 seconds, or at any measuring value change, status telegram approximately every 16 minutes
Range of coverage:	indoors typically 30 - 100 m, outdoors up to 300 m
Housing:	plastic, material ABS, colour pure white (similar to RAL 9010)
Dimensions:	98 x 106 x 32 mm (Frija 2)
Mounting:	wall mounting or on in-wall flush box Ø 55 mm, base with 4-hole for mounting on vertically or horizontally installed in-wall flush boxes
Ambient temperature:	-5...+55 °C
Storage temperature:	-25...+60 °C
Humidity:	0...90% r.H., non-precipitating air
Protection class:	III (according to EN 60 730)
Protection type:	IP 30 (according to EN 60 529)
Standards:	CE conformity according to EMC directive 2014 / 30 / EU and according to R&TTE directive 2014 / 53 / EU

**Dimensional drawing**

**RTF 2 - FSE**  
**RFTF 2 - FSE**

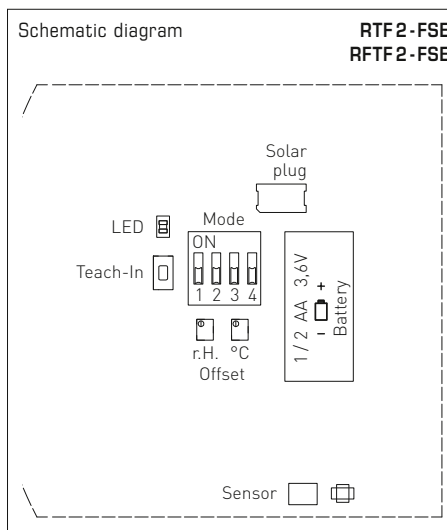
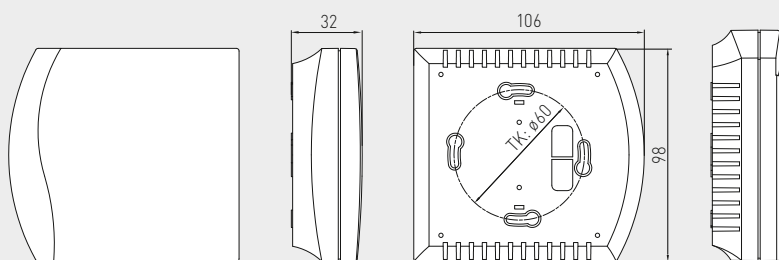

**KYMASGARD® RTF 2 - FSE** Room temperature radio sensors  
**KYMASGARD® RFTF 2 - FSE** Wireless room humidity and temperature radio sensors

Type / WG02	Channels	Measuring Range Temperature Humidity	Energy Generation	Item No.	Price
<b>RTF2-FSE</b>	1	0...+40 °C -	Solar cell, battery	1801-4451-0040-040	<b>130,95 €</b>
<b>RFTF2-FSE</b>	2	0...+40 °C 0...100% r.H.	Solar cell, battery	1801-4452-3040-040	<b>303,10 €</b>
<b>ACCESSORIES</b>					
<b>ET BATTERIE</b>	Lithium battery LS 14250			7000-4000-5000-000	<b>18,80 €</b>
<b>Compatibility</b>	For an overview, see the start of the chapter				



The room temperature sensor **KYMASGARD® RTF 2 - FSE - P** or **RFTF 2 - FSE - P** is a batteryless and maintenance-free radio transmitter. Energy generation is effected by conversion of indoor room light into electric energy by means of a solar generator. These sensors are used to detect the room temperature or room humidity as well as for setpoint setting and to transmit the measurands via radio frequency to radio actuators and radio signal receivers / gateways. If ambient light conditions are insufficient for energy generation, they also can be operated on a lithium battery. To do so, insert the lithium cell into the battery holder provided. The device IDs are marked on a label in the device.

RTF 2 - FSE - P  
RFTF 2 - FSE - P



TECHNICAL DATA	
Operation:	Energy generation by solar cell, batteryless, maintenance-free (optionally battery-operated)
Radio technology:	EnOcean protocol, modulation ASK, 868 MHz, transmission power max. 10 mW, telegram type 4BS
Channels:	1 temperature, 1 humidity, 1 setpoint
Radio transmitter module:	EnOcean Dolphin
Measuring range, temperature:	0...+40 °C
Deviation, temperature:	typically ±0.2 K at +25 °C
Measuring range, humidity:	0...100 % r.H.
Deviation humidity:	typically ±3 % r.H. (30...80 %) at +20 °C
Setpoint capture:	turning angle left 0° = 0 bits turning angle right 220° = 255 bits
Measurand acquisition:	adjustable, every 1s / 10s / 100s
Transmission interval:	adjustable, typically every 100 seconds, or at any measuring value change, or change of turning angle status telegram approximately every 16 minutes
Range of coverage:	indoors typically 30 - 100m, outdoors up to 300 m
Housing:	plastic, material ABS, colour pure white (similar to RAL 9010)
Dimensions:	98 x 106 x 34 mm (Frija2)
Mounting:	wall mounting or on in-wall flush box Ø 55 mm, base with 4-hole for mounting on vertically or horizontally installed in-wall flush boxes
Ambient temperature:	-5...+55 °C
Storage temperature:	-25...+60 °C
Humidity:	0...90 % r.H., non-precipitating air
Protection class:	III (according to EN 60 730)
Protection type:	IP 30 (according to EN 60 529)
Standards:	CE conformity according to EMC directive 2014 / 30 / EU and according to R&TTE directive 2014 / 53 / EU

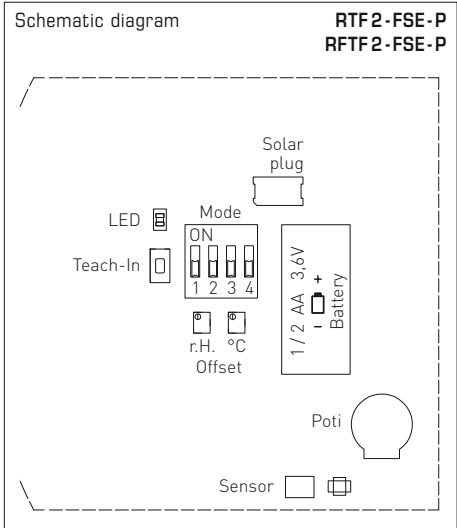
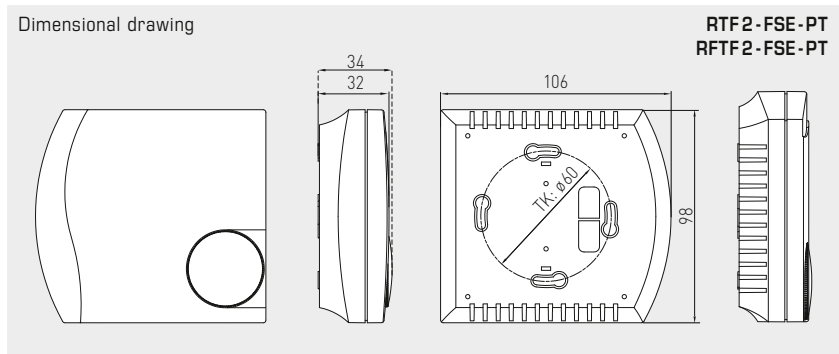

**KYMASGARD® RTF 2 - FSE - P** Room temperature radio sensors  
**KYMASGARD® RFTF 2 - FSE - P** Wireless room humidity and temperature radio sensors

Type / WG02	Channels	Measuring Range Temperature Humidity	Energy Generation	Item No.	Price
RTF2-FSE-P	2	0...+40 °C -	Solar cell, battery	1801-4451-0140-040	153,99 €
RFTF2-FSE-P	3	0...+40 °C 0...100% r.H.	Solar cell, battery	1801-4452-0140-040	321,27 €

ACCESSORIES					
<b>ET BATTERIE</b>	Lithium battery LS 14250			7000-4000-5000-000	18,80 €
<b>BG KNOFF</b>	Control knob (4°C...34°C) for combination with TA2-FEM			7000-4030-0008-058	5,70 €
<b>Compatibility</b>	For an overview, see the start of the chapter				

**Wireless room humidity and temperature radio sensors  
with solar cell, setpoint setter, and push-button**

RTF2-FSE-PT  
RFTF2-FSE-PT

The room temperature sensor **KYMASGARD® RTF 2 - FSE - PT** or **RFTF 2 - FSE - PT** is a batteryless and maintenance-free radio transmitter. Energy generation is effected by conversion of indoor room light into electric energy by means of a solar generator. These sensors are used to detect the room temperature or room humidity as well as for setpoint setting and to transmit the measurands via radio frequency to radio actuators and radio signal receivers / gateways. If ambient light conditions are insufficient for energy generation, they also can be operated on a lithium battery. To do so, insert the lithium cell into the battery holder provided. The device IDs are marked on a label in the device.



**TECHNICAL DATA**

Operation:	Energy generation by solar cell, batteryless, maintenance-free (optionally battery-operated)
Radio technology:	EnOcean protocol, modulation ASK, 868 MHz, transmission power max. 10 mW, telegram type 4BS
Channels:	1 temperature, 1 humidity, 1 setpoint, 1 presence pushbutton
Radio transmitter module:	EnOcean Dolphin
Measuring range, temperature:	0...+40 °C
Deviation, temperature:	typically ±0.2K at +25 °C
Measuring range, humidity:	0...100 % r.H.
Deviation humidity:	typically ±3 % r.H. (30... 80%) at +20 °C
Setpoint capture:	turning angle left 0° = 0 bits turning angle right 220° = 255 bits
Measurand acquisition:	adjustable, every 1s / 10 s / 100 s
Transmission interval:	adjustable, typically every 100 seconds, or at any measuring value change, or change of turning angle status telegram approximately every 16 minutes
Range of coverage:	indoors typically 30 - 100 m, outdoors up to 300 m
Housing:	plastic, material ABS, colour pure white (similar to RAL 9010)
Dimensions:	98 x 106 x 34 mm (Frija 2)
Mounting:	wall mounting or on in-wall flush box Ø 55 mm, base with 4-hole for mounting on vertically or horizontally installed in-wall flush boxes
Ambient temperature:	-5...+55 °C
Storage temperature:	-25...+60 °C
Humidity:	0...90 % r.H., non-precipitating air
Protection class:	III (according to EN 60 730)
Protection type:	IP 30 (according to EN 60 529)
Standards:	CE conformity according to EMC directive 2014 / 30 / EU and according to R&TTE directive 2014 / 53 / EU

**Dimensional drawing**

RTF 2 - FSE - PT  
RFTF 2 - FSE - PT

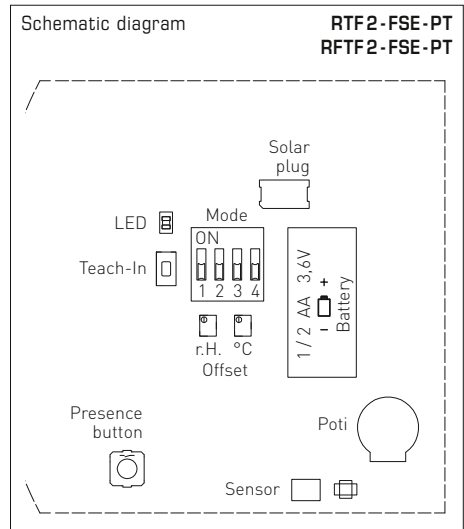
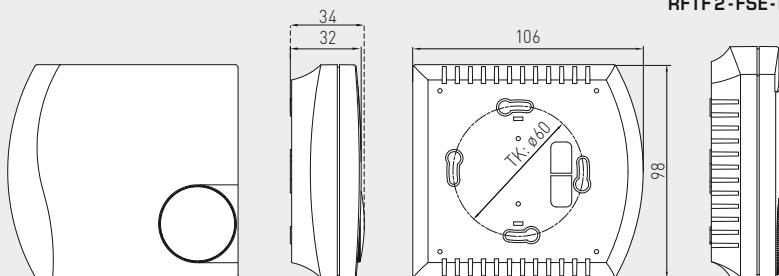

KYMASGARD® RTF 2 - FSE - PT Room temperature radio sensors  
KYMASGARD® RFTF 2 - FSE - PT Wireless room humidity and temperature radio sensors

Type / WG02	Channels	Measuring Range Temperature Humidity	Energy Generation	Item No.	Price
RTF2-FSE-PT	3	0...+40 °C -	Solar cell, battery	1801-4451-0440-040	163,67 €
RFTF2-FSE-PT	4	0...+40 °C 0...100% r.H.	Solar cell, battery	1801-4452-0440-040	330,99 €

**ACCESSORIES**

<b>ET BATTERIE</b>	Lithium battery LS 14250	7000-4000-5000-000	18,80 €
<b>Compatibility</b>	For an overview, see the start of the chapter		



The room temperature sensor KYMASGARD® RTF 2 - FSE - PD or RFTF 2 - FSE - PD is a batteryless and maintenance-free radio transmitter. Energy generation is effected by conversion of indoor room light into electric energy by means of a solar generator. These sensors are used to detect the room temperature or room humidity as well as for setpoint setting and to transmit the measurands via radio frequency to radio actuators and radio signal receivers / gateways. If ambient light conditions are insufficient for energy generation, they also can be operated on a lithium battery. To do so, insert the lithium cell into the battery holder provided. The device IDs are marked on a label in the device.

RTF 2 - FSE - PD  
RFTF 2 - FSE - PD



TECHNICAL DATA	
Operation:	Energy generation by solar cell, batteryless, maintenance-free (optionally battery-operated)
Radio technology:	EnOcean protocol, modulation ASK, 868 MHz, transmission power max. 10 mW, telegram type 4BS
Channels:	1 temperature, 1 setpoint, 1 step switch
Radio transmitter module:	EnOcean Dolphin
Measuring range, temperature:	0...+40 °C
Deviation, temperature:	typically ±0.2 K at +25 °C
Measuring range, humidity:	0...100 % r.H.
Deviation humidity:	typically ±3 % r.H. (30... 80 %) at +20 °C
Setpoint capture:	turning angle left 0° = 0 bits turning angle right 220° = 255 bits Step selection: 0 to 255 bits in steps
Measurand acquisition:	adjustable, every 1s / 10 s / 100 s
Transmission interval:	adjustable, typically every 100 seconds, or at any measuring value change, or change of turning angle status telegram approximately every 16 minutes
Range of coverage:	indoors typically 30 - 100 m, outdoors up to 300 m
Housing:	plastic, material ABS, colour pure white (similar to RAL 9010)
Dimensions:	98 x 106 x 34 mm (Frija 2)
Mounting:	wall mounting or on in-wall flush box Ø 55 mm, base with 4-hole for mounting on vertically or horizontally installed in-wall flush boxes
Ambient temperature:	-5...+55 °C
Storage temperature:	-25...+60 °C
Humidity:	0...90 % r.H., non-precipitating air
Protection class:	III (according to EN 60 730)
Protection type:	IP 30 (according to EN 60 529)
Standards:	CE conformity according to EMC directive 2014 / 30 / EU and according to R&TTE directive 2014 / 53 / EU

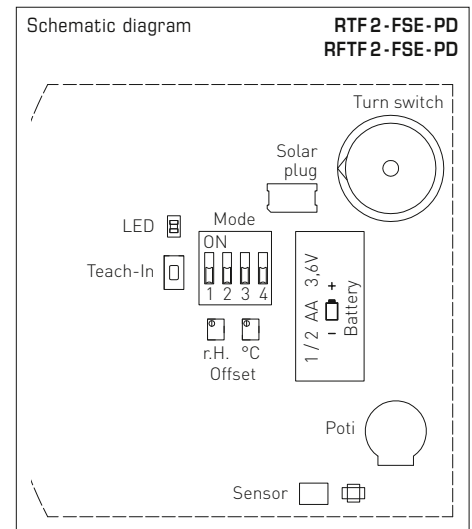
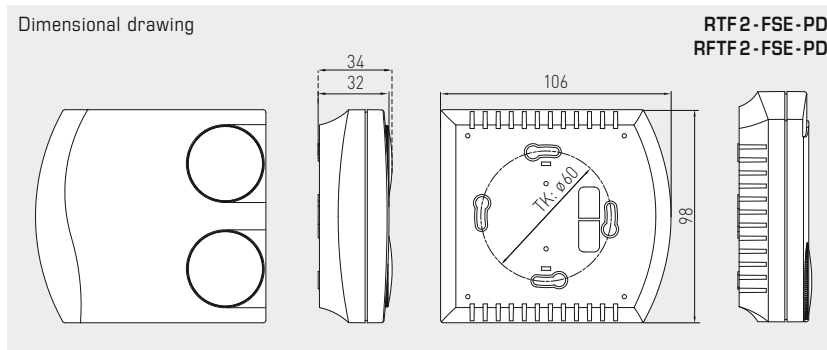

KYMASGARD® RTF 2 - FSE - PD Room temperature radio sensors  
KYMASGARD® RFTF 2 - FSE - PD Wireless room humidity and temperature radio sensors

Type / WG02	Channels	Measuring Range Temperature Humidity	Energy Generation	Item No.	Price
RTF2-FSE-PD2	3	0...+40 °C -	Solar cell, battery	1801-4451-0240-040	184,28 €
RTF2-FSE-PD5	3	0...+40 °C -	Solar cell, battery	1801-4451-0340-040	184,28 €
RFTF2-FSE-PD2	4	0...+40 °C 0...100% r.H.	Solar cell, battery	1801-4452-0240-040	345,54 €

ACCESSORIES	
ET BATTERIE	Lithium battery LS 14250 7000-4000-5000-000 18,80 €
Compatibility	For an overview, see the start of the chapter



**Wireless room temperature radio sensors  
with solar cell, setpoint setter, step selection, and push-button**

The room temperature sensor **KYMASGARD® RTF 2 - FSE - PDT** is a battery-less and maintenance-free radio transmitter. Energy generation is effected by conversion of indoor room light into electric energy by means of a solar generator. These sensors are used to detect the room temperature as well as for setpoint setting and to transmit the measurands via radio frequency to radio actuators and radio signal receivers / gateways. If ambient light conditions are insufficient for energy generation, they also can be operated on a lithium battery. To do so, insert the lithium cell into the battery holder provided. The device IDs are marked on a label in the device.

RTF2-FSE-PDT



**TECHNICAL DATA**

Operation:	Energy generation by solar cell, batteryless, maintenance-free (optionally battery-operated)
Radio technology:	EnOcean protocol, modulation ASK, 868 MHz, transmission power max. 10 mW, telegram type 4BS
Channels:	1 temperature, 1 setpoint, 1 step switch, 1 presence pushbutton
Radio transmitter module:	EnOcean Dolphin
Measuring range, temperature:	0...+40 °C
Deviation, temperature:	typically ±0.2K at +25 °C
Setpoint capture:	turning angle left 0° = 0 bits turning angle right 220° = 255 bits Step selection: 0 to 255 bits in steps
Measurand acquisition:	adjustable, every 1s / 10 s / 100 s
Transmission interval:	adjustable, typically every 100 seconds, or at any measuring value change, presence push-button activation, or change of turning angle status telegram approximately every 16 minutes
Range of coverage:	indoors typically 30 - 100 m, outdoors up to 300 m
Housing:	plastic, material ABS, colour pure white (similar to RAL 9010)
Dimensions:	98 x 106 x 34 mm (Frija 2)
Mounting:	wall mounting or on in-wall flush box Ø 55 mm, base with 4-hole for mounting on vertically or horizontally installed in-wall flush boxes
Ambient temperature:	-5...+55 °C
Storage temperature:	-25...+60 °C
Humidity:	0...90% r.H., non-precipitating air
Protection class:	III (according to EN 60 730)
Protection type:	IP 30 (according to EN 60 529)
Standards:	CE conformity according to EMC directive 2014 / 30 / EU and according to R&TTE directive 2014 / 53 / EU

**Dimensional drawing**

RTF 2 - FSE - PDT

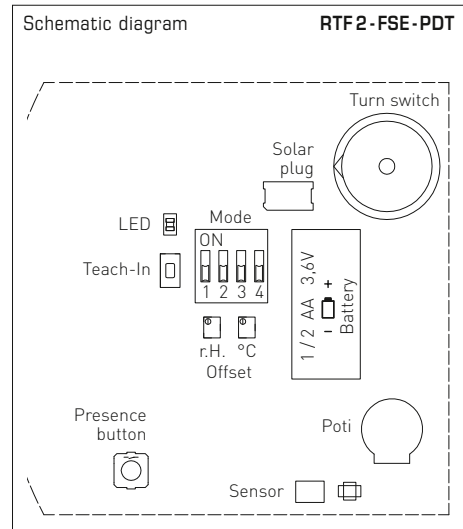
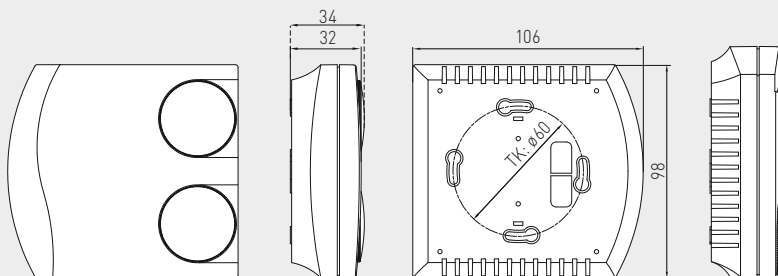

**KYMASGARD® RTF 2 - FSE - PDT** Room temperature radio sensor

Type / WG02	Channels	Measuring Range Temperature Humidity	Energy Generation	Item No.	Price
RTF2-FSE-PD5T	4	0...+40 °C -	Solar cell, battery	1801-4451-0540-040	<b>196,42 €</b>
<b>ACCESSORIES</b>					
ET BATTERIE	Lithium battery LS 14250			7000-4000-5000-000	<b>18,80 €</b>
Compatibility	For an overview, see the start of the chapter				

Radio transmitters as wall pushbutton rocker switches with 2 or 4 channels  
on-wall, panel switch programme

The radio transmitter **KYMASGARD® WT-FSE** is a batteryless and maintenance-free universal transmitter insert with one rocker or two rockers with central position, matching diverse switch programmes of different leading manufacturers.

Rockers are also available as spare parts with and without printing.

Due to its flat design WT-FSE is applicable for wall mounting, also on glass.

**WT-FSE-RW**

(with twin rockers)



**WT-FSE-RW**

(with single rocker)



**TECHNICAL DATA**

Operation:	Energy generation by electrodynamic energy generator (induction principle), batteryless, maintenance-free	
Radio technology:	EnOcean protocol, modulation EIRP / ASK, transmission power max. 10 mW, telegram type RPS-Type 2	
Channels:	2 or 4 channels with 2 statuses each	
Radio transmitter module:	PTM 200	
Operating force:	approx. 7 N at +25°C	
Push-button stroke:	1.8 mm	
Switching cycles:	> 50,000 activations according to EN 60669 / VDE 0632	
Range of coverage:	indoors typically 30 - 100 m, outdoors up to 300 m	
Dimensions:	71 x 71 mm	bottom plate
	55 x 55 mm	frame insert
	55 x 55 mm	single rocker (without frame)
	27.5 x 55 mm	twin rocker (without frame)
Mounting:	on-wall on even surface, for sticking or screw fastening	
Ambient temperature:	-25...+65 °C (in operation)	
Storage temperature:	-40...+85 °C	
Humidity:	0...95 % r.H., non-precipitating air	
Standards:	CE conformity, ROHS conformity according to directive 2011 / 65 / EU	

**SWITCH PROGRAMME**

Manufacturer:	BERKER (S1, B1, B3, B7 glass) GIRA (System 55, E2, Event, Esprit) JUNG (A500, Aplus) MERTEN (M-Smart, M-Arc, M-Plan)
Housing:	plastic, material ABS, colour pure white / matt (similar to RAL 9010), (other colours are available upon request with colour variants depending on the respective light switch programme)

**KYMASGARD® WT-FSE** Radio transmitter as wall pushbutton

Type / WG02	Channels	Printing	Housing Colour	Item No.	Price
<b>WT-FSE</b>					
WT-FSE-RW	2 / 4	-	Pure white / mat	1801-8412-1000-000	<b>96,99 €</b>
WT-FSE-ORW	2 / 4	Light I-O	Pure white / mat	1801-8412-1100-000	<b>96,99 €</b>
WT-FSE-VRW	2 / 4	Venetian blind Δ-▽	Pure white / mat	1801-8412-1200-000	<b>96,99 €</b>
<b>Compatibility</b>	For an overview, see the start of the chapter				

**Radio transmitters as hand-held remote control units with 4 channels**

HT4-FSE

The radio transmitter **KYMASGARD® HT4-FSE** is a battery-less and maintenance-free hand-held transmitter with four independent individual buttons. Because of its ergonomic shape, it sits comfortably in the hand, however can also be fixed to the wall using the relevant adhesive mats.



**TECHNICAL DATA**

Operation:	Energy generation by electrodynamic energy generator (induction principle), batteryless, maintenance-free
Radio technology:	EnOcean protocol, transmission power max. 10 mW, telegram type RPS-Type 2
Channels:	4 channels, each with 2 statuses
Radio transmitter module:	PTM 200
Operating force:	approx. 7 N at +25°C
Push-button stroke:	1.8 mm
Switching cycles:	> 50,000 activations according to EN 60669 / VDE 0632
Range of coverage:	indoors typically 30 - 100 m, outdoors up to 300 m
Dimensions:	48 x 81 x 19 mm (W x H x D)
Housing:	plastic, material ABS, colours see table
Ambient temperature:	-25...+55 °C (in operation)
Storage temperature:	-40...+85 °C
Humidity:	0...95 % r.H., non-precipitating air
Standards:	CE conformity according to EMC directive 2014 / 30 / EU and according to R&TTE directive 2014 / 53 / EU

**KYMASGARD® HT4 - FSE** Radio transmitters as hand-held remote control units

Type / WG02	Channels	Housing Colour	Item No.	Price
<b>HT4-FSE</b>				
HT4-FSE-RW	4	Pure white	1801-8424-1000-000	<b>116,40 €</b>
HT4-FSE-SW	4	Black	1801-8424-2000-000	<b>116,40 €</b>
HT4-FSE-SB	4	Silver	1801-8424-3000-000	<b>116,40 €</b>
<b>Compatibility</b>	For an overview, see the start of the chapter			



The radio transmitter **KYMASGARD® FK1 - FSE** is a battery-less and maintenance-free window contact with one channel. Energy generation is effected by conversion of indoor room light into electric energy by means of a solar generator. It is used for status monitoring of windows and doors employing a reed contact with counter magnet and to transmit the results via radio signal to radio actuators and radio receivers / gateways. It is suitable for mounting on window and door frames made of wood, glass, and aluminium.

FK1-FSE

TECHNICAL DATA	
Operation:	energy generation by electrodynamic solar generator, batteryless, maintenance-free
Radio technology:	EnOcean protocol, modulation ASK, transmission power max. 10 mW
Channels:	1 status, 1 control
Radio transmitter module:	STM100
Status acquisition:	reed contact
Measurand acquisition:	every 1000 seconds
Transmission interval:	every 1000 seconds, or at any status change
Range of coverage:	indoors typically 30 - 100m, outdoors up to 300m
Dimensions:	110 x 19 x 15 mm (L x W x D)
Housing:	plastic, material ABS, colour pure white (similar to RAL 9010)
Mounting:	on-wall on even surface, for sticking or screw fastening
Ambient temperature:	-25...+65 °C (in operation)
Storage temperature:	-40...+85 °C
Humidity:	0...70 % r. H., non-precipitating air
Protection type:	IP 20 (according to EN 60 529)
Standards:	CE conformity, ROHS conformity according to directive 2011 / 65 / EU



KYMASGARD® FK1-FSE Radio transmitter as door and window contact unit				
Type / WG02	Channels	Housing Colour	Item No.	Price
<b>FK1-FSE</b>				
FK1-FSE-RW	1	Pure white	1801-8431-1000-000	<b>110,44 €</b>
<b>Compatibility</b>	For an overview, see the start of the chapter			

**Gateway  
for RS485 bus, bidirectional**

The KYMASGARD® GW-RS485-FEM is a device for on-wall installation. It serves as unidirectional or bidirectional gateway between radio transmitters / radio receivers and bus systems on basis of RS485 communication. It enables receiving and transmitting of radio telegrams from all radio transmitters that comply with the EnOcean protocol standard.

GW-RS485-FEM



**TECHNICAL DATA**

Operating mode:	receiving (from up to 30 radio transmitters) and transmitting of radio telegrams according to EnOcean standard
Rated voltage:	10 - 24 V DC
Current consumption:	45 mA at 12 V DC
Radio module:	TCM320
Fusing:	none
Operating elements:	1 button ("LRN") 1 button („CLR") 5 LEDs
Connection:	5-pole terminal screw
Housing:	plastic, material ABS, colour pure white (similar to RAL 9010)
Dimensions:	85 x 91 x 27 mm (Frija 1)
Mounting:	wall mounting or on in-wall flush box, Ø 55 mm, base with 4 holes, for attachment to vertically or horizontally installed in-wall flush boxes for rear cable entry, with predetermined breaking point for cable entry from top/bottom in case of plain on-wall installation
Ambient temperature:	-5...+40°C (in operation)
Humidity:	5...90% r.H., non-precipitating air
Protection type:	IP 20 (according to EN 60 529)
Standards:	CE conformity, EN 090-2-2, EN 60669-2-1, ROHS conformity according to Directive 2011 / 65 / EU

Dimensional drawing

GW-RS485-FEM

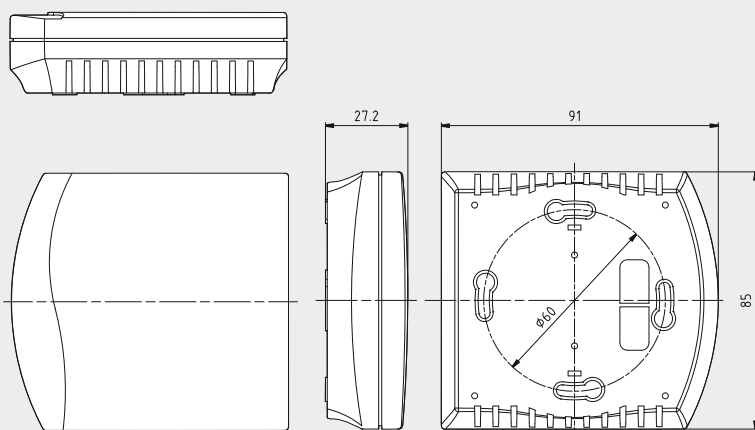

Schematic diagram

GW-RS485-FEM

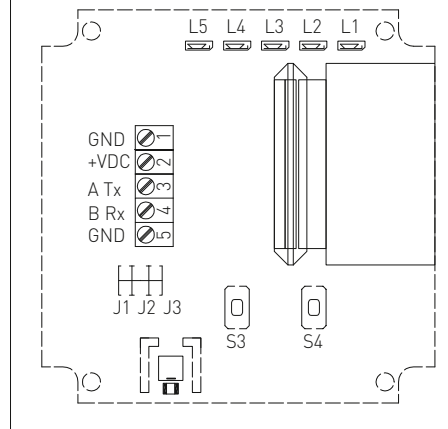

**KYMASGARD® GW-RS485-FEM Gateway for RS485-Bus**

Type / WG02	Type	Communication	Installation	Item No.	Price
<b>GW-RS485-FEM</b>					
GW-RS485-FEM	Bidirectional	RS485	On-wall	1801-7429-0022-300	<b>208,84 €</b>
<b>Note:</b>	other gateways optional			on request	
<b>Compatibility</b>	all KYMASGARD® radio transmitters and radio signal receivers				





The Venetian blind actuator **KYMASGARD® JA100-FEM-UP** is a device with one channel for in-wall or on-wall installation. Initiated by up to 30 radio transmitters (wall-mounted and hand-held transmitters, motion detectors, outdoor light sensor) as well as by the two auxiliary inputs, a roller shutter/blind motor can be controlled via its output channel.

Each taught-in transmitter can be assigned a different function such as a sequential pushbutton function or a 10-minute switch-off delay. The repeater function can be additionally activated by means of a simple procedure.

## JA100-FEM-UP



TECHNICAL DATA	
Operating mode:	moving Up/Down (long push of button), adjusting blades (short push of button)
Radio technology:	EnOcean protocol, modulation ASK, 868 MHz, transmission power max. 10 mW, telegram type 4BS
Rated voltage:	110 - 240 V, 50 / 60 Hz
Fusing:	16 A
Operating elements:	2 buttons ("LRN"/"CLR") 2 LEDs ("LRN"/"CLR") 1 rotary switch with 16 positions
Channels:	1 channel
Standby consumption:	0.6W
Load output / Connected load:	2 secured normally open contacts rated current: 6 A / 240 V AC max. switch-on current: 10 A max. switching capacity AC1: 1500 VA max. switching capacity AC15: 300 VA motor load 1Ph AC3 / 230 V AC: 0.185 kW capacitive load: 10 µF
Switching properties:	parametrisable
Connection:	4 mm <sup>2</sup> , via terminal screws
Housing:	Plastic, material ABS, Ø 51 mm, height 25 mm
Mounting:	In-wall, on-wall
Ambient temperature:	-20...+40 °C (in operation)
Storage temperature:	-40...+85 °C
Permitted humidity:	5...90% r.H., non-precipitating air
Protection type:	IP 20 (according to EN 60 529)
Standards:	CE conformity, EN 090-2-2, EN 60669-2-1, ROHS conformity according to directive 2011 / 65 / EU

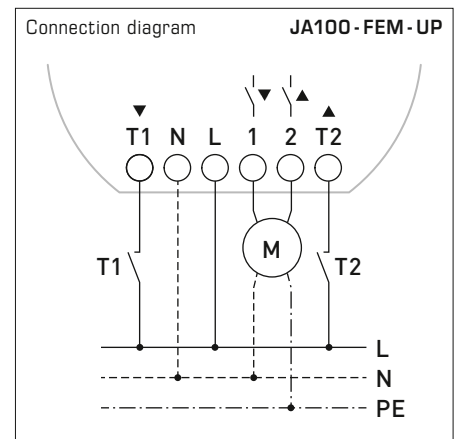

KYMASGARD® JA100-FEM-UP Venetian blind actuator						
Type / WG02	Channels	Switching element	Installation	Item no.	Price	
<b>JA100-FEM-UP</b>						
JA100-FEM-UP	1	Normally open contact	In-wall	1801-7441-0500-300	<b>187,56 €</b>	
<b>Compatibility</b>	For an overview, see the start of the chapter					

**Radio receiver,  
switching actuator with 1 channel,  
in-wall**

The switching actuator **KYMASGARD® SA100-FEM-UP** is a device with one channel for in-wall or on-wall installation and is used for switching electric consumers. Initiated by up to 30 radio transmitters (wall-mounted and hand-held transmitters, motion detectors, window contact) a group of electric consumers can be switched.

Each taught-in transmitter can be assigned a different function such as a sequential pushbutton function or a 10-minute switch-off delay. The repeater function can be additionally activated by means of a simple procedure.

SA100-FEM-UP



**TECHNICAL DATA**

Operating mode:	switching ON/OFF, pulse switch, stepping switch
Radio technology:	EnOcean protocol, modulation ASK, 868 MHz, transmission power max. 10 mW, telegram type 4BS
Rated voltage:	110 - 240 V, 50 / 60 Hz
Fusing:	16 A
Operating elements:	2 buttons ("LRN"/"CLR") 2 LEDs ("LRN"/"CLR") 1 rotary switch with 16 positions
Channels:	1 channel
Standby consumption:	0.6 W
Load output / Connected load:	normally open contact potential free rated current: 16 A / 250 V AC max. switch-on current: 130 A / 20 ms max. switching capacity AC1: 4000 VA max. switching capacity AC15: 750 VA filament bulbs: 2000 W halogen lamps 230 V AC: 2000 W fluorescent lamps, uncompensated: 1000 W fluorescent lamps, compensated: 750 W fluorescent lamps, duo-connection: 1000 W motor load 1Ph AC3 / 230 V AC: 1 kW electronic ballast assuming 30 µF: 3 unit capacitive load: 30 µF
Switching properties:	parametrisable
Connection:	4 mm <sup>2</sup> , via terminal screws
Housing:	Plastic, material ABS, Ø 51 mm, height 25 mm
Mounting:	In-wall, on-wall
Ambient temperature:	-20...+40 °C (in operation)
Storage temperature:	-40...+85 °C
Permitted humidity:	5...90% r.H., non-precipitating air
Protection type:	IP 20 (according to EN 60 529)
Standards:	CE conformity, EN 090-2-2, EN 60669-2-1, ROHS conformity according to directive 2011 / 65 / EU

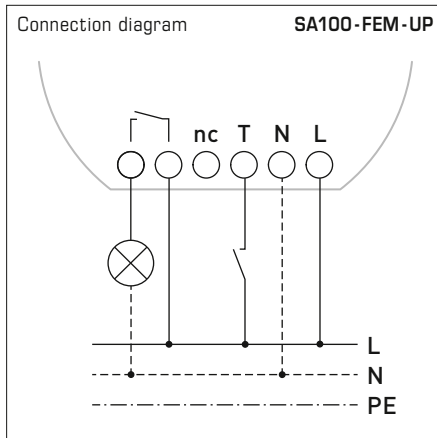

**KYMASGARD® SA100 - FEM - UP** Switching actuator

Type / WG02	Channels	Switching element	Installation	Item no.	Price
<b>SA100-FEM-UP</b>					
SA100-FEM-UP	1	Normally open contact	In-wall	1801-7441-0200-300	<b>165,55 €</b>
<b>Compatibility</b>	For an overview, see the start of the chapter				



The switching actuator **KYMASGARD® SA200-FEM-UP** is a device with two channels for in-wall or on-wall installation. Initiated by up to 30 radio transmitters (wall-mounted and hand-held transmitters, motion detectors, outdoor light sensors) and the two auxiliary inputs, two groups of electric consumers can be switched via its two outputs. Each taught-in transmitter can be assigned a different function such as a sequential pushbutton function or a 10-minute switch-off delay. The repeater function can be additionally activated by means of a simple procedure.

SA200-FEM-UP



TECHNICAL DATA	
Operating mode:	switching ON/OFF, pulse switch, stepping switch
Radio technology:	EnOcean protocol, modulation ASK, 868 MHz, transmission power max. 10 mW, telegram type 4BS
Rated voltage:	110 - 240 V, 50 / 60 Hz
Fusing:	16 A
Operating elements:	2 buttons ("LRN"/"CLR") 2 LEDs ("LRN"/"CLR") 1 rotary switch with 16 positions
Channels:	2 channels
Standby consumption:	0.6 W
Load output / Connected load:	normally open contact rated current: 6 A / 240 V AC max. switch-on current: 10 A max. switching capacity AC1: 1500 VA max. switching capacity AC15: 300 VA filament bulbs: 750 W halogen lamps 230 V AC: 500 W fluorescent lamps, uncompensated: 300 W fluorescent lamps, compensated: 200 W fluorescent lamps, duo-connection: 300 W motor load 1Ph AC3 / 230 V AC: 0.185 kW electronic ballast assuming 30 µF: 1 unit capacitive load: 10 µF
Switching properties:	parametrisable
Connection:	4 mm <sup>2</sup> , via terminal screws
Housing:	Plastic, material ABS, Ø 51 mm, height 25 mm
Mounting:	In-wall, on-wall
Ambient temperature:	-20...+40 °C (in operation)
Storage temperature:	-40...+85 °C
Permitted humidity:	5...90% r.H., non-precipitating air
Protection type:	IP 20 (according to EN 60 529)
Standards:	CE conformity, EN 090-2-2, EN 60669-2-1, ROHS conformity according to directive 2011 / 65 / EU

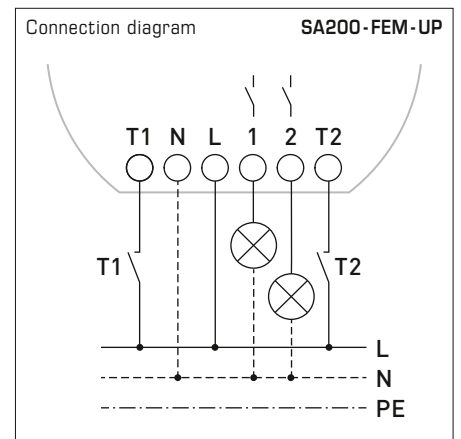

KYMASGARD® SA200-FEM-UP Switching actuator						
Type / WG02	Channels	Switching element	Installation	Item no.	Price	
<b>SA200-FEM-UP</b>						
SA200-FEM-UP	2	Normally open contact	In-wall	1801-7443-0200-300	<b>187,56 €</b>	
<b>Compatibility</b>	For an overview, see the start of the chapter					

**Radio receiver,  
thermostat actuator with 1 channel,  
in-wall**

TA100-FEM-UP

The thermostat actuator KYMASGARD® TA100-FEM-UP is a device with one channel for in-wall or on-wall installation. With the help of a room temperature sensor (see compatibility overview) and up to 8 radio window contacts (FK1-FSE) in AND conjunction, a group of electric consumers (control valves, electric heating units, etc.) can be switched by a two-position control with frost protection function via an output. Different functions can be allocated to that output, depending on the parameter setting.



### TECHNICAL DATA

Operating mode:	switching ON/OFF, pulse switch, stepping switch
Radio technology:	EnOcean protocol, modulation ASK, 868 MHz, transmission power max. 10 mW, telegram type 4BS
Rated voltage:	110 - 240 V, 50 / 60 Hz
Fusing:	16 A
Operating elements:	2 buttons ("LRN"/"CLR") 2 LEDs ("LRN"/"CLR") 1 rotary switch with 16 positions
Channels:	1 channel
Standby consumption:	0.6 W
Load output / Connected load:	normally open contact potential free rated current: 16 A / 250 V AC max. switch-on current: 130 A / 20 ms max. switching capacity AC1: 4000 VA max. switching capacity AC15: 750 VA motor load 1Ph AC3 / 230 V AC: 1 kW capacitive load: 30 µF
Switching properties:	parametrisable
Connection:	4 mm <sup>2</sup> , via terminal screws
Housing:	Plastic, material ABS, Ø 51 mm, height 25 mm
Mounting:	In-wall, on-wall
Ambient temperature:	-20...+40 °C (in operation)
Storage temperature:	-40...+85 °C
Permitted humidity:	5...90% r.H., non-precipitating air
Protection type:	IP 20 (according to EN 60 529)
Standards:	CE conformity, EN 090-2-2, EN 60669-2-1, ROHS conformity according to directive 2011 / 65 / EU

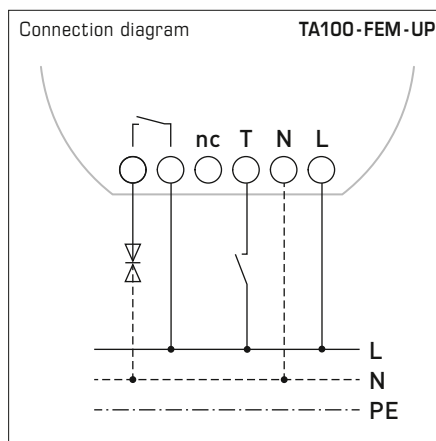

### KYMASGARD® TA100 - FEM - UP Thermostat actuator

Type/WG02	Channels	Switching element	Installation	Item no.	Price
<b>TA100-FEM-UP</b>					
TA100-FEM-UP	1	Normally open contact	In-wall	1801-7441-0600-300	<b>165,55 €</b>
<b>Compatibility</b>	For an overview, see the start of the chapter				



Radio receiver,  
thermostat actuator with 2 channels,  
in-wall

TA200-FEM-UP

The thermostat actuator **KYMASGARD® TA200-FEM-UP** is a device with two channels for in-wall or on-wall installation. With the help of a room temperature sensor (see compatibility overview) and up to 8 radio window contacts (FK1-FSE) in AND conjunction, a group of electric consumers (control valves, electric heating units, etc.) can be switched by a two-position control with frost protection function via an output. Different functions can be allocated to that output, depending on the parameter setting.

**TECHNICAL DATA**

Operating mode:	switching ON/OFF, pulse switch, stepping switch
Radio technology:	EnOcean protocol, modulation ASK, 868 MHz, transmission power max. 10 mW, telegram type 4BS
Rated voltage:	110 - 240 V, 50 / 60 Hz
Fusing:	16 A
Operating elements:	2 buttons ("LRN"/"CLR") 2 LEDs ("LRN"/"CLR") 1 rotary switch with 16 positions
Channels:	2 channels
Standby consumption:	0.6W
Load output / Connected load:	normally open contact rated current: 6 A / 240 V AC max. switch-on current: 10 A max. switching capacity AC1: 1500 VA max. switching capacity AC15: 300 VA motor load 1Ph AC3 / 230 V AC: 0.185 kW capacitive load: 10 µF
Switching properties:	parametrisable
Connection:	4 mm <sup>2</sup> , via terminal screws
Housing:	Plastic, material ABS, Ø 51 mm, height 25 mm
Mounting:	In-wall, on-wall
Ambient temperature:	-20...+40 °C (in operation)
Storage temperature:	-40...+85 °C
Permitted humidity:	5...90 % r.H., non-precipitating air
Protection type:	IP 20 (according to EN 60 529)
Standards:	CE conformity, EN 090-2-2, EN 60669-2-1, ROHS conformity according to directive 2011 / 65 / EU

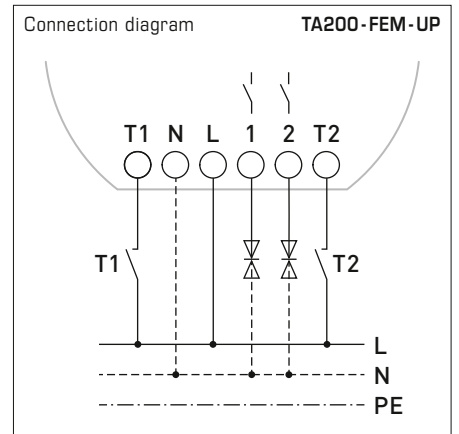
**KYMASGARD® TA200-FEM-UP** Thermostat actuator

Type / WG02	Channels	Switching element	Installation	Item no.	Price
<b>TA200-FEM-UP</b>					
TA200-FEM-UP	2	Normally open contact	In-wall	1801-7443-0600-300	<b>187,56 €</b>
<b>Compatibility</b>	For an overview, see the start of the chapter				



Radio transmitter,  
pushbutton interface with 4 channels,  
in-wall

The pushbutton interface **KYMASGARD® IN400-FSE-UP** is a device with four channels for in-wall or on-wall installation and is used for detecting up to four 230 V AC switching/sensor contacts. A corresponding radio telegram is sent every time the status of the 230 V AC switching/sensor contact changes.

IN400 - FSE - UP



**TECHNICAL DATA**

Radio technology:	EnOcean protocol, modulation ASK, 868 MHz, transmission power max. 10 mW, telegram type RPS-Type 2
Rated voltage:	110 - 240 V, 50 / 60 Hz
Fusing:	10 A
Operating elements:	2 buttons ("LRN"/"CLR") 2 LEDs ("LRN"/"CLR") 1 rotary switch with 16 positions
Channels:	4 channels, each with 2 statuses
Standby consumption:	0.4 W
Inputs:	100 V - 230 V AC inputs
Behaviour:	like a transmitter with PTM 200 (wall-mounted transmitter)
Range of coverage:	indoors typically 30 - 100 m, outdoors up to 300 m
Connection:	4 mm <sup>2</sup> , via terminal screws
Housing:	Plastic, material ABS, Ø 51 mm, height 25 mm
Mounting:	In-wall, on-wall
Ambient temperature:	-20...+40 °C (in operation)
Storage temperature:	-40...+85 °C
Permitted humidity:	5...90% r.H., non-precipitating air
Protection type:	IP 20 (according to EN 60 529)
Standards:	CE conformity, EN 090-2-2, EN 60669-2-1, ROHS conformity according to directive 2011 / 65 / EU

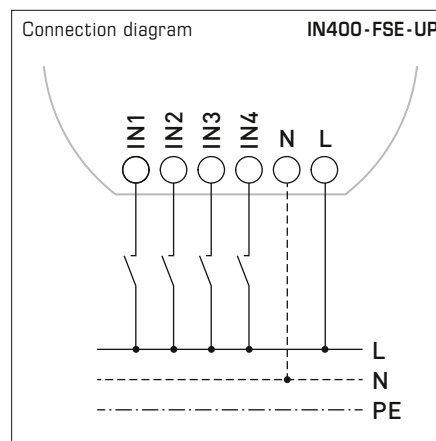

**KYMASGARD® IN400 - FSE - UP Pushbutton interface**

Type / WG02	Channels	Installation	Item no.	Price
<b>IN400-FSE-UP</b>				
IN400-FSE-UP	4	In-wall	1801-7444-0100-300	<b>147,94 €</b>
<b>Compatibility</b>	For an overview, see the start of the chapter			



The Venetian blind actuator KYMASGARD® JA200-FEM-AP is a device with two channels for in-wall or on-wall installation. Initiated by up to 30 radio transmitters (wall-mounted and hand-held transmitters, motion detectors, outdoor light sensor) as well as by the four auxiliary inputs, two roller shutter/blind motors can be controlled independently via its four auxiliary inputs.

Different functions can be allocated to that output, depending on the parameter setting. The repeater function can be additionally activated by means of a simple procedure.

JA200 - FEM - AP



TECHNICAL DATA	
Operating mode:	moving Up / Down (long push of button), adjusting blades (short push of button)
Radio technology:	EnOcean protocol, modulation ASK, 868 MHz, transmission power max. 10 mW, telegram type 4BS
Rated voltage:	110 - 240 V, 50 / 60 Hz
Fusing:	16 A
Operating elements:	2 buttons ("LRN"/"CLR") 2 LEDs ("LRN"/"CLR") 1 rotary switch with 16 positions
Channels:	2 channels
Standby consumption:	0.6 W
Load output / Connected load:	4 secured normally open contacts, potential-free rated current: 16 A / 250 V AC max. switch-on current: 130 A / 20 ms max. switching capacity AC1: 4000 VA max. switching capacity AC15: 750 VA motor load 1Ph AC3 / 230 V AC: 1 kW capacitive load: 30 µF
Switching properties:	parametrisable
Connection:	4 mm <sup>2</sup> , via terminal screws
Housing:	plastic, material ABS, 170 x 85 x 40 mm
Mounting:	On-wall
Ambient temperature:	-20...+40 °C (in operation)
Storage temperature:	-40...+85 °C
Permitted humidity:	5...90 % r.H., non-precipitating air
Protection type:	IP 42 (according to EN 60 529)
Standards:	CE conformity, EN 090-2-2, EN 60669-2-1, ROHS conformity according to directive 2011 / 65 / EU

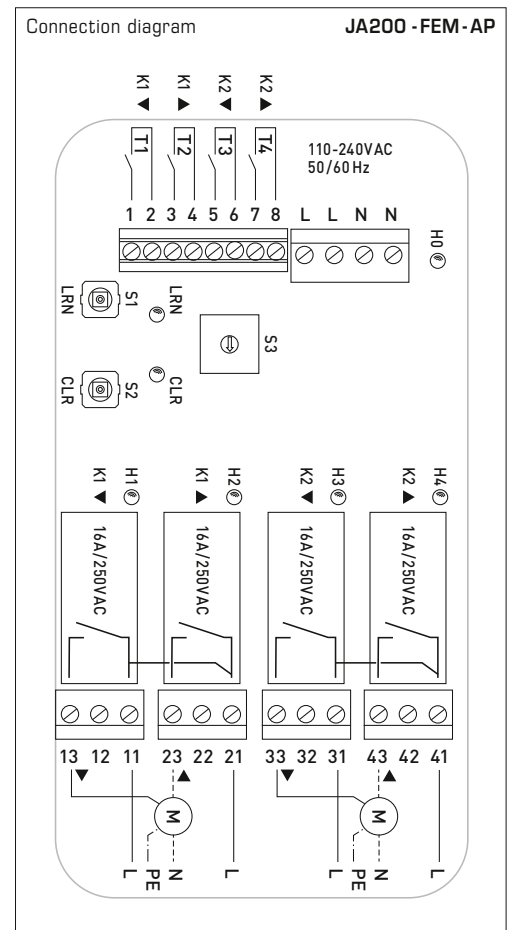

KYMASGARD® JA200 - FEM - AP Venetian blind actuator						
Type / WG02	Channels	Switching element	Installation	Item no.	Price	
<b>JA200 - FEM - AP</b>						
JA200-FEM-AP	2	Normally open contact	On-wall	1801-7453-0500-300	<b>292,00 €</b>	
<b>Compatibility</b>	For an overview, see the start of the chapter					

**Radio receiver,  
switching actuator with 4 channels,  
on-wall**

The switching actuator **KYMASGARD® SA400-FEM-AP** is a device with four potential-free channels for on-wall installation. Initiated by up to 30 radio transmitters (wall-mounted and hand-held transmitters, motion detectors, outdoor light sensors) and the auxiliary inputs, up to four different groups of electric consumers can be switched.

Each taught-in transmitter can be assigned a different function such as a sequential pushbutton function or a 10-minute switch-off delay. The repeater function can be additionally activated by means of a simple procedure.

SA400 - FEM - AP



**TECHNICAL DATA**

Operating mode:	switching ON/OFF (long push of button), pulse switch, stepping switch
Radio technology:	EnOcean protocol, modulation ASK, 868 MHz, transmission power max. 10 mW, telegram type 4BS
Rated voltage:	110 - 240 V, 50 / 60 Hz
Fusing:	16 A
Operating elements:	2 buttons ("LRN"/"CLR") 2 LEDs ("LRN"/"CLR") 1 rotary switch with 16 positions
Channels:	4 channels
Standby consumption:	0.6 W
Load output / Connected load:	normally open contact potential free rated current: 16 A / 250 V AC max. switch-on current: 130 A / 20 ms max. switching capacity AC1: 4000 VA max. switching capacity AC15: 750 VA filament bulbs: 2000 W halogen lamps 230 V AC: 2000 W fluorescent lamps, uncompensated: 1000 W fluorescent lamps, compensated: 750 W fluorescent lamps, duo-connection: 1000 W motor load 1Ph AC3 / 230 V AC: 1 kW electronic ballast assuming 30 µF: 3 unit capacitive load: 30 µF
Switching properties:	parametrisable
Connection:	4 mm <sup>2</sup> , via terminal screws
Housing:	plastic, material ABS, 170 x 85 x 40 mm
Mounting:	On-wall
Ambient temperature:	-20...+40 °C (in operation)
Storage temperature:	-40...+85 °C
Permitted humidity:	5...90 % r.H., non-precipitating air
Protection type:	IP 42 (according to EN 60529)
Standards:	CE conformity, EN 090-2-2, EN 60669-2-1, ROHS conformity according to directive 2011 / 65 / EU

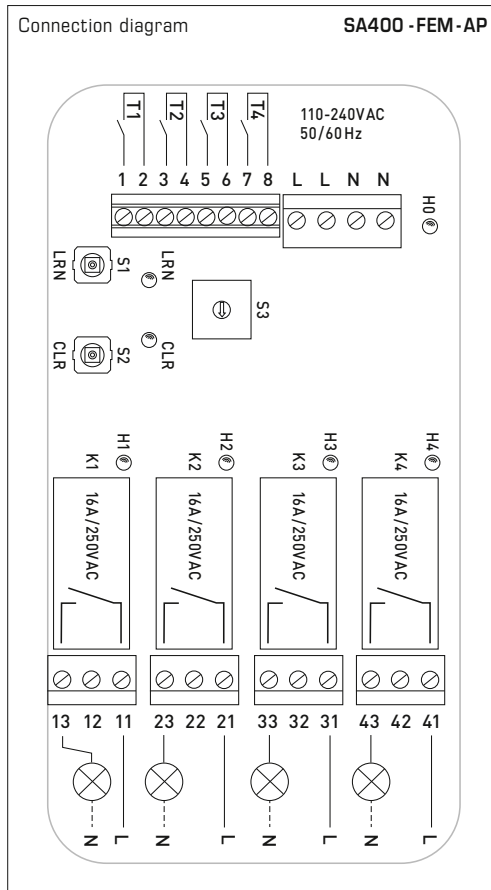

**KYMASGARD® SA400 - FEM - AP** Switching actuator

Type / WG02	Channels	Switching element	Installation	Item no.	Price
<b>SA400 - FEM - AP</b>					
SA400-FEM-AP	4	Normally open contact	On-wall	1801-7454-0200-300	<b>315,49 €</b>
<b>Compatibility</b>	For an overview, see the start of the chapter				



The control valve actuator **KYMASGARD® SV600 - FEM - AP** is a device with six channels for on-wall installation. Initiated by up to 30 radio transmitters (wall-mounted and hand-held transmitters, motion detectors, room temperature sensor, window contact), up to six electrothermic actuators in 2-position control can be controlled for room temperature regulation.

The corresponding fixed function, such as the selection of the operating mode, frost protection function, etc., is assigned directly when teaching-in the transmitter. The repeater function can be additionally activated by means of a simple procedure.

SV600 - FEM - AP



TECHNICAL DATA	
Operating mode:	switching ON/OFF in 2-position control
Radio technology:	EnOcean protocol, modulation ASK, 868 MHz, transmission power max. 10 mW, telegram type 4BS
Rated voltage:	110 - 240 V, 50 / 60 Hz
Fusing:	16 A
Operating elements:	2 buttons ("LRN"/"CLR") 2 LEDs ("LRN"/"CLR") 1 rotary switch with 16 positions
Channels:	6 channels
Standby consumption:	0.6 W
Load output / Connected load:	electronic switching contact rated current: 2 A / 250 V AC max. switch-on current: 2 A / 2 ms max. switching capacity AC1: 500 VA
Switching properties:	parametrisable
Connection:	4 mm <sup>2</sup> , via terminal screws
Housing:	plastic, material ABS, 170 x 85 x 40 mm
Mounting:	On-wall
Ambient temperature:	-20...+40 °C (in operation)
Storage temperature:	-40...+85 °C
Permitted humidity:	5...90% r.H., non-precipitating air
Protection type:	IP 42 (according to EN 60 529)
Standards:	CE conformity, EN 090-2-2, EN 60669-2-1, ROHS conformity according to directive 2011 / 65 / EU

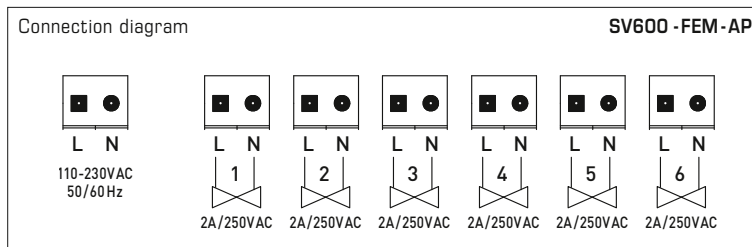

KYMASGARD® SV600 - FEM - AP Control valve actuator					
Type / WG02	Channels	Switching element	Installation	Item no.	Price
<b>SV600 - FEM - AP</b>					
SV600-FEM-AP	6	electronic	On-wall	1801-7456-0800-300	<b>288,61 €</b>
<b>Compatibility</b>	For an overview, see the start of the chapter				

**Multifunctional outside radio sensor  
for humidity, temperature and light intensity,  
with solar cell**

The multifunctional outside sensor **KYMASGARD® AFTF-HK-FSE** is a maintenance-free radio transmitter without battery for on-wall installation. Energy is generated by converting outdoor light into electric energy by means of a solar generator. It is used to detect the outside temperature, outdoor humidity and outdoor light intensity and to transmit the measurands via radio signal to radio actuators and radio receivers/gateways.

AFTF-HK-FSE



**TECHNICAL DATA**

Operation:	Energy generation by solar cell, batteryless, maintenance-free
Radio technology:	EnOcean protocol, modulation ASK, 868 MHz, transmission power max. 10 mW, telegram type 4BS
Channels:	1 temperature, 1 humidity, 1 light intensity
Radio transmitter module:	EnOcean Dolphin
Measurand acquisition:	adjustable, every 1s / 10s / 100s
Transmission interval:	adjustable, typically every 100 seconds, or at any measuring value change, status telegram approximately every 16 minutes
Range of coverage:	Indoors typically 30-100m, outdoors up to 300m

**HUMIDITY**

Operating range, humidity:	0...100% r. H.
Deviation in humidity:	typically $\pm 2.0\%$ (20...80% r.H.) at +25 °C, otherwise $\pm 3.0\%$

**TEMPERATURE**

Operating range, temperature:	-20...+60 °C
Deviation in temperature:	typically $\pm 0.2\text{K}$ at +25 °C

**LIGHT INTENSITY**

Light intensity operating range:	<b>Multi-range switching</b> 0...2000 Lux / 0...60 kLux
Deviation in light intensity:	typically < 5% of final value

Housing:	Plastic, UV-resistant, polyamide material, 30% glass-globe reinforced, with quick-locking screws (slotted / Phillips head combination), traffic white colour (similar to RAL 9016), housing cover is transparent!
----------	---

Housing dimensions:	72 x 64 x 43.3 mm (Tyr 1)
---------------------	---------------------------

Protective tube:	<b>made of stainless steel V2A</b> (1.4301), $\varnothing = 16\text{ mm}$ , NL = 55 mm
------------------	--

Sensor protection:	<b>plastic</b> sinter filter, $\varnothing 16\text{ mm}$ , L = 35 mm, exchangeable (optional <b>metal</b> sinter filter, $\varnothing 16\text{ mm}$ , L = 32 mm)
--------------------	--

Ambient temperature:	-25...+60 °C
----------------------	--------------

Storage temperature:	-25...+60 °C
----------------------	--------------

Permitted humidity:	0...90% r.H., non-precipitating air
---------------------	-------------------------------------

Protection class:	III (according to EN 60 730)
-------------------	------------------------------

Protection type:	<b>IP 65</b> (according to EN 60 529) Housing tested, TÜV SÜD, Report No. 713139052 (Tyr 1)
------------------	---

Standards:	CE conformity according to EMC Directive 2014 / 30 / EU and according to R&TTE Directive 2014 / 53 / EU
------------	---

SF-M

**Metal sinter filter** (optional)



Dimensional drawing

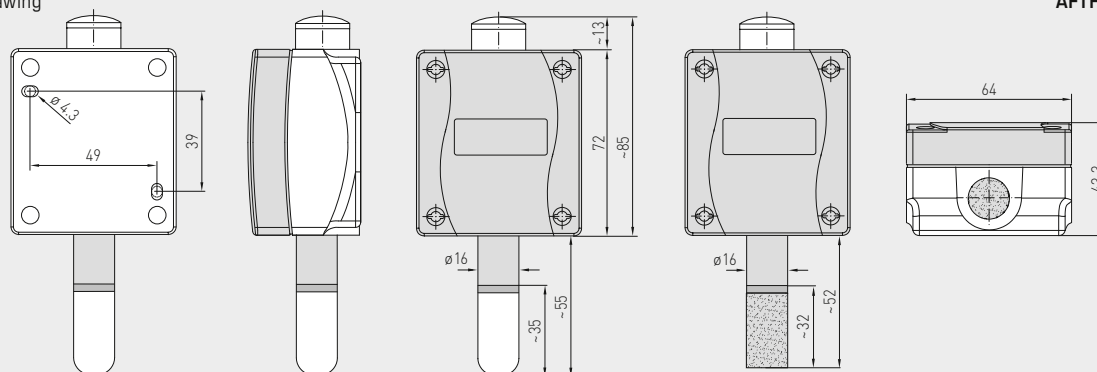

AFTF-HK-FSE

**KYMASGARD® AFTF-HK-FSE** Outside radio sensor for humidity, temperature and light intensity

Type / WG02	Channels	Measuring ranges			Item no.	Price
		Temperature	Humidity	Light intensity		
<b>AFTF-HK-FSE</b>				(switchable)		
AFTF-HK-FSE	3	-20...+60 °C	0...100%r.H.	0...2000 Lux / 0...60 kLux	1801-1140-1000-000	<b>262,53 €</b>
<b>Compatibility</b>	For an overview, see the start of the chapter					





Multifunctional outside radio sensor  
for wind strength and light intensity,  
with solar cell

AWSF-HK-FSE

The multifunctional outside radio sensor KYMASGARD® AWSF-HK-FSE is a maintenance-free radio sensor without battery for on-wall installation. Energy is generated by converting outdoor light into electric energy by means of a solar generator. It is used to detect the wind speed and outdoor light intensity and to transmit to the measurands via radio signal to radio actuators and radio receivers / gateways.

TECHNICAL DATA	
Operation:	Energy generation by solar cell, batteryless, maintenance-free
Radio technology:	EnOcean protocol, modulation ASK, 868 MHz, transmission power max. 10 mW, telegram type 4BS
Channels:	1 wind speed, 1 light intensity
Radio transmitter module:	EnOcean Dolphin
Measurand acquisition:	adjustable, 1s / 10 s / 100 s and on event
Transmission interval:	adjustable, typically every 100 seconds at any measuring value change, status telegram approximately every 16 minutes
Range of coverage:	Indoors typically 30 - 100 m, outdoors up to 300 m
WIND STRENGTH	
Wind operating range:	0..100 km/h
Wind deviation:	typically $\pm 5$ km/h
LIGHT INTENSITY	
Light intensity operating range:	<b>Multi-range switching</b> 0..2000 Lux / 0..60 kLux
Deviation in light intensity:	typically < 5% of final value
Housing:	plastic, PC material, UV-resistant light grey colour (similar to RAL 7035)
Housing dimensions:	approx. 200 x 50 x 50 mm
Mounting:	Wall-mounted via screws, on-wall
Ambient temperature:	-25...+60 °C
Storage temperature:	-25...+60 °C
Permitted humidity:	0...90% r.H., non-precipitating air
Protection class:	III (according to EN 60 730)
Protection type:	<b>IP 54</b> (according to EN 60 529)
Standards:	CE conformity according to EMC Directive 2014 / 30 / EU and according to R&TTE Directive 2014 / 53 / EU



KYMASGARD® AWSF-HK-FSE Outside radio sensor for wind strength and light intensity				
Type / WG02	Channels	Measuring ranges	Item no.	Price
AWSF-HK-FSE		Wind strength		
		Light intensity		
AWSF-HK-FSE	2	0..100 km/h	1801-1150-5000-000	328,07 €
<b>Compatibility</b>	For an overview, see the start of the chapter			



## Accessories

Take advantage of our comprehensive range of accessories, which can be used together with our entire product portfolio. This keeps you always a step ahead, and best of all: If you buy and stock up, you will also save on the price.

Our standard devices normally differ in type of design and sensors. Depending on the application, you can install S+S accessories directly on site.



## IMMERSION SLEEVES & ACCESSORIES

634 – 653

### Immersion sleeves

<b>TH 08</b>	Immersion sleeves for temperature sensors	<b>636</b>
<b>TH</b>	Immersion sleeves for temperature sensors	<b>638</b>
<b>THR</b>	Immersion sleeves for temperature controllers	<b>640</b>
<b>THE</b>	Immersion sleeves for sleeve sensors	<b>642</b>

### Mounting accessories

<b>MFT-20-K</b>	Mounting flange, plastic	<b>644</b>
<b>MF-xx-K</b>	Mounting flange, plastic	<b>644</b>
<b>MF-xx-M</b>	Mounting flange, metal	<b>645</b>
<b>KRD-04</b>	Capillary tube gland bracket, plastic	<b>644</b>
<b>MK-xx</b>	Mounting brackets	<b>645</b>
<b>ESSH</b>	Welding protection sleeve	<b>646</b>
<b>KVSS / KVST</b>	Clamp connections	<b>646</b>
<b>TH-Adapter-HW</b>	Immersion sleeve adapter (Honeywell / Centraline)	<b>646</b>

### Accessories for differential pressure switches

<b>ASD-06</b>	Connection set	<b>647</b>
<b>ASD-07</b>	Connection nipple (90°)	<b>647</b>
<b>ASS-UV</b>	Connection hose, UV-resistant	<b>647</b>
<b>DAL</b>	Pressure outlet	<b>647</b>
<b>DS-MW</b>	Mounting bracket, sheet steel	<b>647</b>

### Protection hoods

<b>WS-01</b>	Sun and ball-impact protection hood	<b>648</b>
<b>WS-03</b>	Weather and sun protection hood (Tyr 2)	<b>648</b>
<b>WS-04</b>	Weather and sun protection hood (Tyr 1)	<b>648</b>

### Spare parts, small parts

<b>SF-xx</b>	Sinter filters, replaceable	<b>649</b>
<b>PSW-09</b>	Stainless steel paddle (SW)	<b>649</b>
<b>PWFS-08</b>	Stainless steel vane (WFS)	<b>649</b>
<b>WH-20</b>	Wall holder (KH)	<b>649</b>
<b>HS-Adapter</b>	Universal holder for small housing (top hat rails)	<b>649</b>
<b>Modbus-Y</b>	Y-adapter for cable gland	<b>649</b>
<b>SPB-1</b>	Strap for surface-contact sensor	<b>649</b>
<b>WLP-1</b>	Heat-conductive paste, silicone-free	<b>649</b>

### Special accessories for plug-in connectors

Connection accessories, A-coded, 5-pin or 12-pin	<b>650</b>
Connection accessories, EtherCAT-coded, 4-pin	<b>651</b>

### Miscellaneous

Optional services, single services	<b>652</b>
Custom-made products	<b>653</b>

# THERMASGARD® TH 08

Immersion sleeves made of stainless steel or brass, nickel-plated, for temperature sensors and measuring transducers

TF 43, TM 43, TF 65, TM 65, TM 65-Modbus (Tyr 1)



S+S REGELTECHNIK

Dimensional drawing TH08-ms/xx

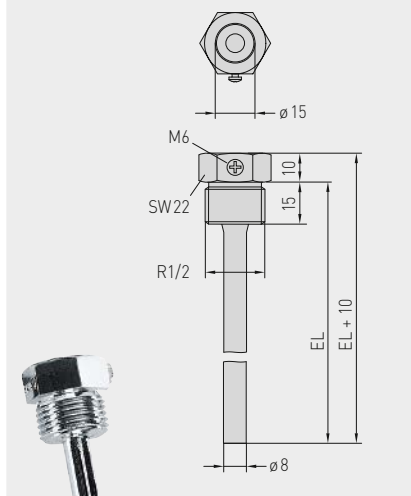

### TH08-ms/xx

Immersion sleeve, nickel-plated brass  
thread-sealing, conical,  
according to DIN 10226

Dimensional drawing TH08-VA/xx

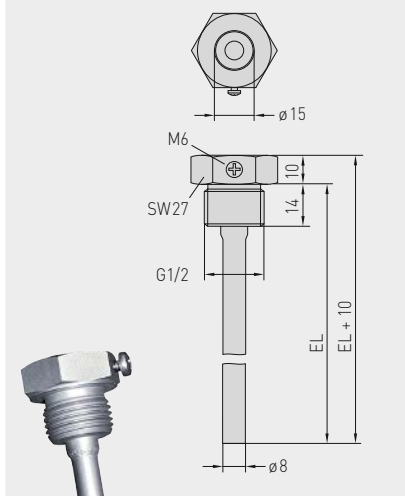

### TH08-VA/xx

Immersion sleeve, stainless steel V4A (1.4571)  
flat sealing, cylindrical,  
according to DIN 228

Dimensional drawing TH08-VA/xx/90

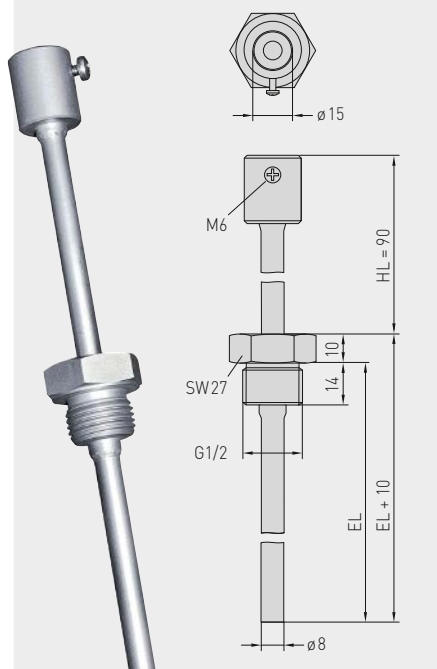

### TH08-VA/xx/90

Immersion sleeve, stainless steel V4A (1.4571)  
with neck tube  
flat sealing, cylindrical,  
according to DIN 228

## THERMASGARD® TH 08 Immersion sleeve Ø 8 mm

Type / WGD1	p <sub>max</sub> (static)	T <sub>max</sub>	Inserted length (EL)	Item No.	Price
<b>TH08-<u>ms</u>/xx</b>	<b>Brass nickel-plated</b>			<b>Ø 8 x 0.75 mm</b>	
TH08-MS 50MM	10 bar	+150 °C	50 mm	7100-0011-0010-132	8,87 €
TH08-MS 100MM	10 bar	+150 °C	100 mm	7100-0011-0020-132	10,10 €
TH08-MS 150MM	10 bar	+150 °C	150 mm	7100-0011-0030-132	10,67 €
TH08-MS 200MM	10 bar	+150 °C	200 mm	7100-0011-0040-132	11,01 €
TH08-MS 250MM	10 bar	+150 °C	250 mm	7100-0011-0050-132	12,75 €
TH08-MS 300MM	10 bar	+150 °C	300 mm	7100-0011-0060-132	13,10 €
TH08-MS 350MM	10 bar	+150 °C	350 mm	7100-0011-0070-132	13,21 €
TH08-MS 400MM	10 bar	+150 °C	400 mm	7100-0011-0080-132	13,33 €
<b>TH08-<u>VA</u>/xx</b>	<b>Stainless steel V4A (1.4571)</b>			<b>Ø 8 x 0.75 mm</b>	
TH08-VA 50MM	40 bar	+600 °C	50 mm	7100-0012-0010-132	19,31 €
TH08-VA 100MM	40 bar	+600 °C	100 mm	7100-0012-0020-132	21,34 €
TH08-VA 150MM	40 bar	+600 °C	150 mm	7100-0012-0030-132	22,93 €
TH08-VA 200MM	40 bar	+600 °C	200 mm	7100-0012-0040-132	24,17 €
TH08-VA 250MM	40 bar	+600 °C	250 mm	7100-0012-0050-132	30,05 €
TH08-VA 300MM	40 bar	+600 °C	300 mm	7100-0012-0060-132	31,40 €
TH08-VA 350MM	40 bar	+600 °C	350 mm	7100-0012-0070-132	31,61 €
TH08-VA 400MM	40 bar	+600 °C	400 mm	7100-0012-0080-132	32,17 €
<b>TH08-<u>VA</u>/xx/90</b>	<b>Stainless steel V4A (1.4571), with neck tube (90mm)</b>			<b>Ø 8 x 0.75 mm</b>	
TH08-VA 50/90MM	40 bar	+600 °C	50 mm	7100-0012-0012-132	27,66 €
TH08-VA 100/90MM	40 bar	+600 °C	100 mm	7100-0012-0022-132	28,90 €
TH08-VA 150/90MM	40 bar	+600 °C	150 mm	7100-0012-0032-132	30,32 €
TH08-VA 200/90MM	40 bar	+600 °C	200 mm	7100-0012-0042-132	31,61 €
TH08-VA 250/90MM	40 bar	+600 °C	250 mm	7100-0012-0052-132	33,13 €
TH08-VA 300/90MM	40 bar	+600 °C	300 mm	7100-0012-0062-132	35,91 €

Note: Inner diameter of socket 15.0 mm



**INSTRUCTIONS FOR PLANNING AND INSTALLATION**

The approaching flow causes the protective tube to vibrate.

If the specified approach velocity is exceeded even by a marginal amount, a negative impact on the protective tube's service life may result (material fatigue).

Please observe permissible approach velocities for stainless steel protective tubes (see graph TH08-VA) as well as for brass protective tubes (see graph TH08-ms).

Discharge of gases and pressure surges must be avoided as they have a negative influence on the service life and may damage the protective tubes irreparably.

**MIXING SECTION**

After the mixing of water flows of different temperatures, the issue of temperature stratification means that an adequate distance to the sensor must be observed.

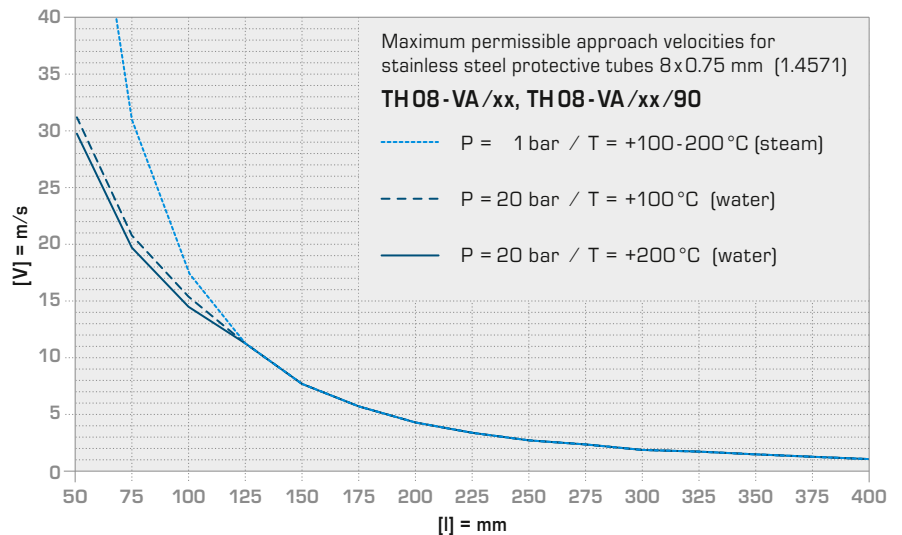
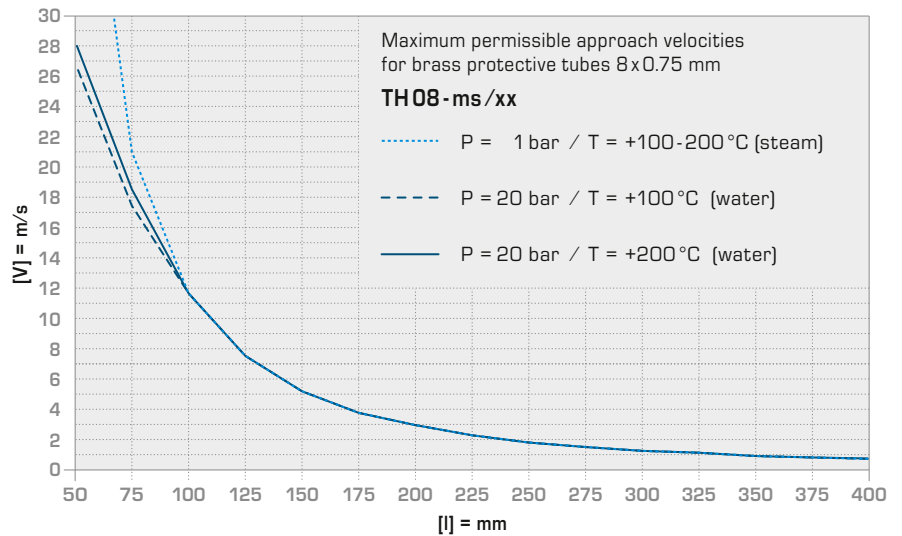
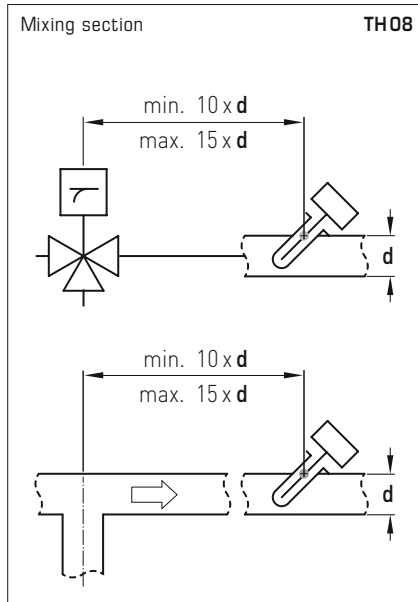

**When Copper and Zinc are Not Enough**

Uncompromising quality and safety are also paramount in the design of the accessory from S+S. This is why our metal immersion sleeves for duct sensors are made using either nickel plated brass or stainless steel. Brass is an alloy consisting mainly of copper and zinc, which provide good forming and machining properties, mechanical strength, temperature resistance and electrical conductivity.

In contrast to conventional products in the market, however, our brass immersion sleeves feature an additional nickel coating. This ensures their longterm corrosion resistance in minor aggressive media, from air and water to alkaline solutions and diluted acids. At the same time, the nickel layer prevents ingredients in thermally conductive compounds from stripping the copper and causing pitting.

Highest protection against corrosion is provided by immersion sleeves made of stainless steel. Among the available qualities, we chose VA 1.4571 or AISI 316 Ti, a high-grade austenite specialty combining chromium, nickel and molybdenum with an extra titanium content. The alloy has a proven fit particularly in the design of chemical process equipment and technical instruments as well as in waste gas and water treatment. Its corrosion resistance also includes chlorides or salts and more aggressive acids, such as hydrochloric acid (HCl).

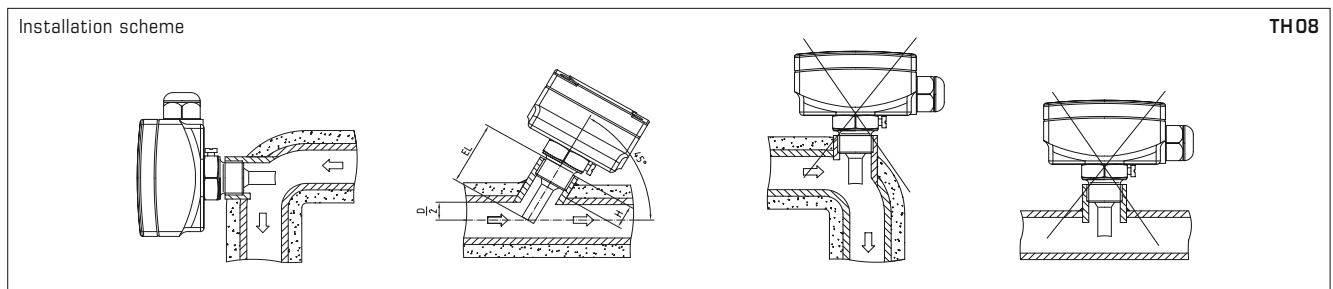

# THERMASGARD® TH

Immersion sleeves made of stainless steel or brass, nickel-plated, for temperature sensors and measuring transducers TF 54/TM 54 (form B)



S+S REGELTECHNIK

Dimensional drawing TH-ms/xx

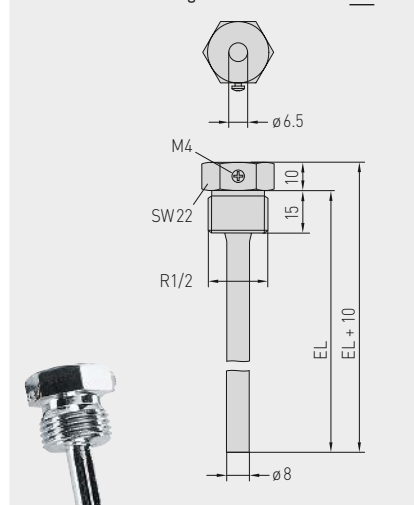

### TH-ms/xx

Immersion sleeve, nickel-plated brass  
thread-sealing, conical, according to DIN 10226

Dimensional drawing TH-VA/xx

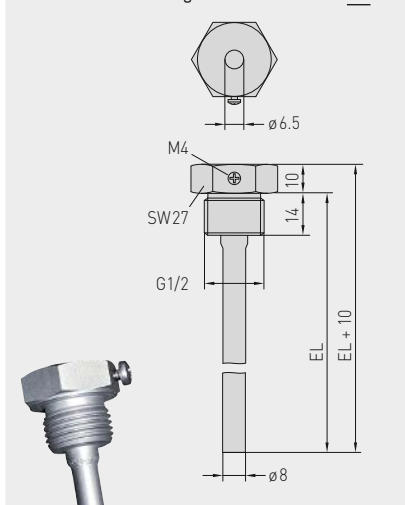

### TH-VA/xx

Immersion sleeve, stainless steel V4A (1.4571)  
flat sealing, cylindrical, according to DIN 228

Dimensional drawing TH-VA/xx/90

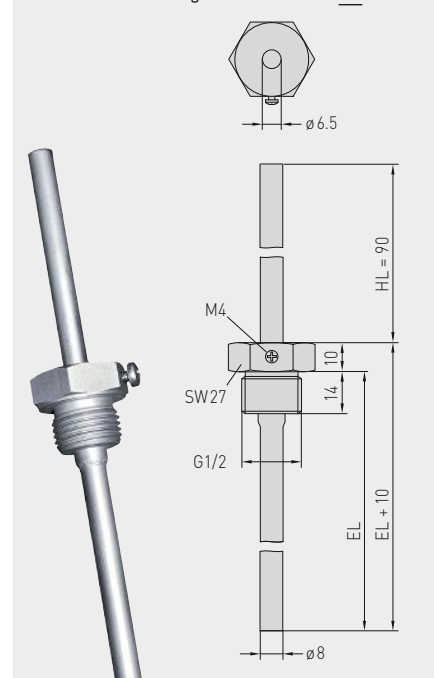

### TH-VA/xx/90

Immersion sleeve, stainless steel V4A (1.4571) with neck tube  
flat sealing, cylindrical, according to DIN 228

THERMASGARD® TH Immersion sleeve Ø 8 mm					
Type / WGD1	p <sub>max</sub> (static)	T <sub>max</sub>	Inserted length (EL)	Item No.	Price
<b>TH-<u>ms</u>/xx</b>	<b>Brass nickel-plated</b>			<b>Ø 8 x 0.75 mm</b>	
TH-MS 50MM	10 bar	+150 °C	50 mm	7100-0011-0010-001	8,87 €
TH-MS 100MM	10 bar	+150 °C	100 mm	7100-0011-0020-001	10,10 €
TH-MS 150MM	10 bar	+150 °C	150 mm	7100-0011-0030-001	10,67 €
TH-MS 200MM	10 bar	+150 °C	200 mm	7100-0011-0040-001	11,01 €
TH-MS 250MM	10 bar	+150 °C	250 mm	7100-0011-0050-001	12,75 €
TH-MS 300MM	10 bar	+150 °C	300 mm	7100-0011-0060-001	13,10 €
TH-MS 350MM	10 bar	+150 °C	350 mm	7100-0011-0070-001	13,21 €
TH-MS 400MM	10 bar	+150 °C	400 mm	7100-0011-0080-001	13,33 €
<b>TH-<u>VA</u>/xx</b>	<b>Stainless steel V4A (1.4571)</b>			<b>Ø 8 x 0.75 mm</b>	
TH-VA 50MM	40 bar	+600 °C	50 mm	7100-0012-0010-001	19,31 €
TH-VA 100MM	40 bar	+600 °C	100 mm	7100-0012-0020-001	21,34 €
TH-VA 150MM	40 bar	+600 °C	150 mm	7100-0012-0030-001	22,93 €
TH-VA 200MM	40 bar	+600 °C	200 mm	7100-0012-0040-001	24,17 €
TH-VA 250MM	40 bar	+600 °C	250 mm	7100-0012-0050-001	30,05 €
TH-VA 300MM	40 bar	+600 °C	300 mm	7100-0012-0060-001	31,40 €
TH-VA 350MM	40 bar	+600 °C	350 mm	7100-0012-0070-001	31,61 €
TH-VA 400MM	40 bar	+600 °C	400 mm	7100-0012-0080-001	32,17 €
<b>TH-<u>VA</u>/xx/90</b>	<b>Stainless steel V4A (1.4571), with neck tube (90mm)</b>			<b>Ø 8 x 0.75 mm</b>	
TH-VA 50/90MM	40 bar	+600 °C	50 mm	7100-0012-2010-001	27,66 €
TH-VA 100/90MM	40 bar	+600 °C	100 mm	7100-0012-2020-001	28,90 €
TH-VA 150/90MM	40 bar	+600 °C	150 mm	7100-0012-2030-001	30,32 €
TH-VA 200/90MM	40 bar	+600 °C	200 mm	7100-0012-2040-001	31,61 €
TH-VA 250/90MM	40 bar	+600 °C	250 mm	7100-0012-2050-001	33,13 €
TH-VA 300/90MM	40 bar	+600 °C	300 mm	7100-0012-2060-001	35,91 €

Note: Inner diameter of socket 6.5 mm



Immersion sleeves made of stainless steel or brass, nickel-plated, for temperature sensors and measuring transducers TF54/TM54 (form B)

**INSTRUCTIONS FOR PLANNING AND INSTALLATION**

The approaching flow causes the protective tube to vibrate.

If the specified approach velocity is exceeded even by a marginal amount, a negative impact on the protective tube's service life may result (material fatigue).

Please observe permissible approach velocities for stainless steel protective tubes (see graph TH-VA) as well as for brass protective tubes (see graph TH-ms).

Discharge of gases and pressure surges must be avoided as they have a negative influence on the service life and may damage the protective tubes irreparably.

**MIXING SECTION**

After the mixing of water flows of different temperatures, the issue of temperature stratification means that an adequate distance to the sensor must be observed.

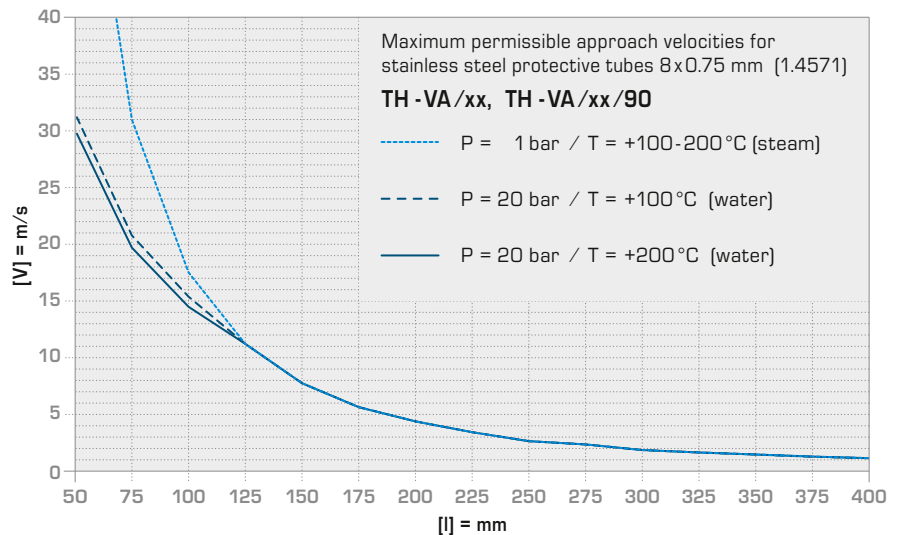
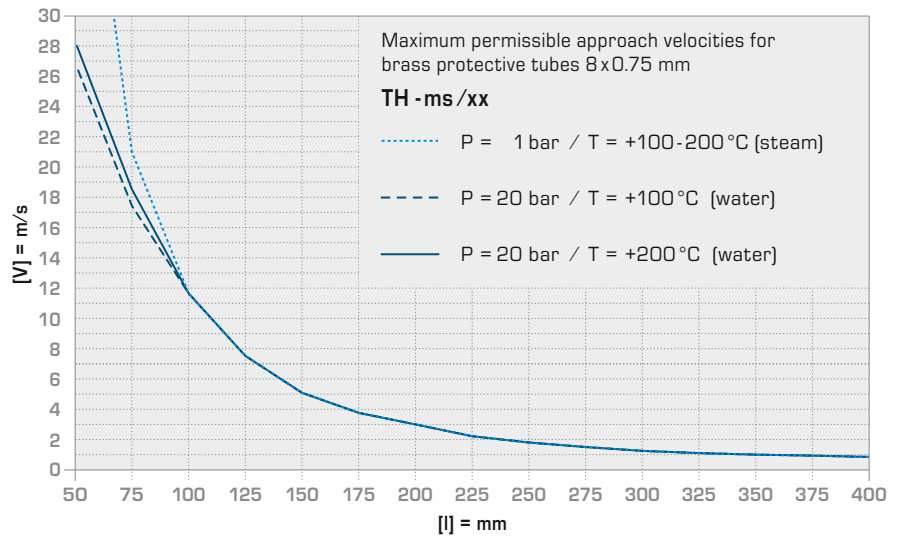
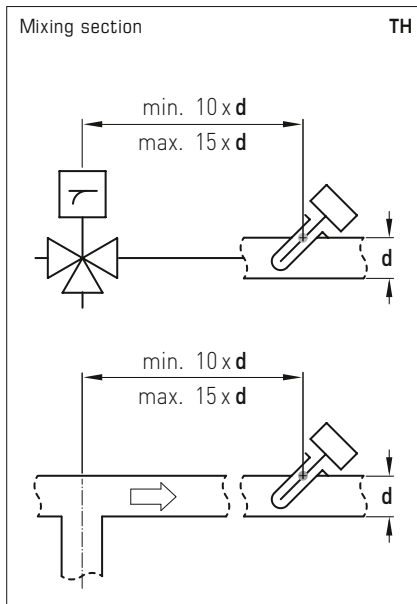

**When Copper and Zinc are Not Enough**

Uncompromising quality and safety are also paramount in the design of the accessory from S+S. This is why our metal immersion sleeves for duct sensors are made using either nickel plated brass or stainless steel. Brass is an alloy consisting mainly of copper and zinc, which provide good forming and machining properties, mechanical strength, temperature resistance and electrical conductivity.

In contrast to conventional products in the market, however, our brass immersion sleeves feature an additional nickel coating. This ensures their longterm corrosion resistance in minor aggressive media, from air and water to alkaline solutions and diluted acids. At the same time, the nickel layer prevents ingredients in thermally conductive compounds from stripping the copper and causing pitting.

Highest protection against corrosion is provided by immersion sleeves made of stainless steel. Among the available qualities, we chose VA 1.4571 or AISI 316 Ti, a high-grade austenite specialty combining chromium, nickel and molybdenum with an extra titanium content. The alloy has a proven fit particularly in the design of chemical process equipment and technical instruments as well as in waste gas and water treatment. Its corrosion resistance also includes chlorides or salts and more aggressive acids, such as hydrochloric acid (HCl).

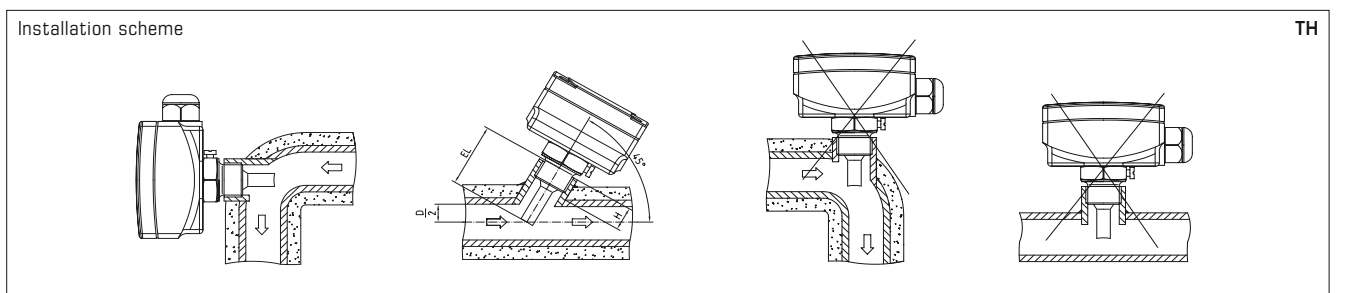

## THERMASGARD® THR

Immersion sleeves made of stainless steel or brass, nickel-plated, for temperature controllers ETR (Thor 2)



S+S REGELTECHNIK

Dimensional drawing **THR -ms-08 / xx**

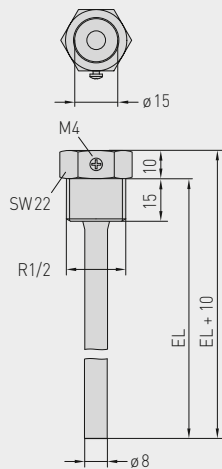

### THR -ms-08 / xx

Immersion sleeve, nickel-plated brass  
thread-sealing, conical, according to DIN 10226

Dimensional drawing **THR -VA-09 / xx**

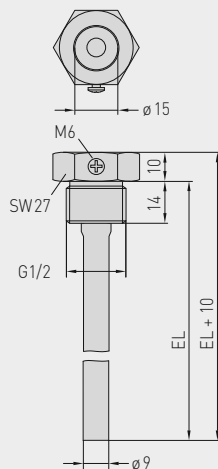

### THR -VA-09 / xx

Immersion sleeve, stainless steel V4A (1.4571)  
flat sealing, cylindrical, according to DIN 228

Dimensional drawing **THR -VA-17 / xx**

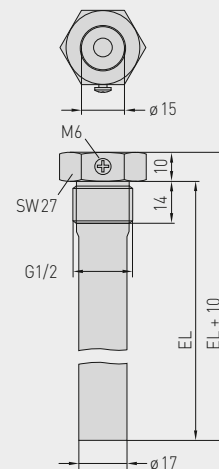

### THR -VA-17 / xx

Immersion sleeve, stainless steel V4A (1.4571)  
flat sealing, cylindrical, according to DIN 228

#### When Copper and Zinc are Not Enough

Uncompromising quality and safety are also paramount in the design of the accessory from S+S. This is why our metal immersion sleeves for duct sensors are made using either nickel plated brass or stainless steel. Brass is an alloy consisting mainly of copper and zinc, which provide good forming and machining properties, mechanical strength, temperature resistance and electrical conductivity.

In contrast to conventional products in the market, however, our brass immersion sleeves feature an additional nickel coating. This ensures their longterm corrosion resistance in minor aggressive media, from air and water to alkaline solutions and diluted acids. At the same time, the nickel layer prevents ingredients in thermally conductive compounds from stripping the copper and causing pitting.

Highest protection against corrosion is provided by immersion sleeves made of stainless steel. Among the available qualities, we chose VA 1.4571 or AISI 316 Ti, a high-grade austenite specialty combining chromium, nickel and molybdenum with an extra titanium content. The alloy has a proven fit particularly in the design of chemical process equipment and technical instruments as well as in waste gas and water treatment. Its corrosion resistance also includes chlorides or salts and more aggressive acids, such as hydrochloric acid (HCl).

#### THERMASGARD® THR Immersion sleeve Ø 8 / 9 / 17 mm for THERMASREG® ETR (Thor 2)

Type / WG01	p <sub>max</sub> (static)	T <sub>max</sub>	Time Constant for Medium:			Inserted Length (EL)	Item No. Ø	Price
			Air	Water	Oil			
<b>THR -ms-08 / xx</b>	<b>Brass nickel-plated</b>						<b>Ø 8 x 0.5 mm</b>	
THR-MS-08/100	10 bar	+150 °C	106 s	18 s	53 s	<b>100 mm</b>	7100-0011-3022-000	<b>14,69 €</b>
THR-MS-08/150	10 bar	+150 °C	106 s	18 s	53 s	<b>150 mm</b>	7100-0011-3404-000	<b>14,81 €</b>
THR-MS-08/200	10 bar	+150 °C	106 s	18 s	53 s	<b>200 mm</b>	7100-0011-3403-000	<b>17,59 €</b>
<b>THR -VA-09 / xx</b>	<b>Stainless steel V4A (1.4571)</b>						<b>Ø 9 x 1.0 mm</b>	
THR-VA-09/100	25 bar	+150 °C	92 s	17 s	41 s	<b>100 mm</b>	7100-0012-3022-000	<b>37,83 €</b>
THR-VA-09/150	25 bar	+150 °C	92 s	17 s	41 s	<b>150 mm</b>	7100-0012-3032-000	<b>39,04 €</b>
THR-VA-09/200	25 bar	+150 °C	92 s	17 s	41 s	<b>200 mm</b>	7100-0012-3042-000	<b>41,83 €</b>
<b>THR -VA-17 / xx</b>	<b>Stainless steel V4A (1.4571)</b>						<b>Ø 17 x 1.0 mm</b>	
THR-VA-17/150	25 bar	+150 °C	-	45 s	55 s	<b>150 mm</b>	7100-0012-3033-000	<b>39,04 €</b>
THR-VA-17/200	25 bar	+150 °C	-	45 s	55 s	<b>200 mm</b>	7100-0012-3404-000	<b>41,83 €</b>
Ordering example:	THR -ms-08 / <b>100</b> (Brass immersion sleeve, Ø = 8 mm, <b>EL = 100 mm</b> ) THR -VA-09 / <b>150</b> (Stainless steel immersion sleeve, Ø = 9 mm, <b>EL = 150 mm</b> ) THR -VA-17 / <b>200</b> (Stainless steel immersion sleeve, Ø = 17 mm, <b>EL = 200 mm</b> )							
Note:	inner diameter of socket 15.0 mm							

**INSTRUCTIONS FOR PLANNING AND INSTALLATION**

The approaching flow causes the protective tube to vibrate.

If the specified approach velocity is exceeded even by a marginal amount, a negative impact on the protective tube's service life may result (material fatigue).

Please observe permissible approach velocities for stainless steel protective tubes (see graph **THR-VA**) as well as for brass protective tubes (see graph **THR-ms**).

Discharge of gases and pressure surges must be avoided as they have a negative influence on the service life and may damage the protective tubes irreparably.

**MIXING SECTION**

After the mixing of water flows of different temperatures, the issue of temperature stratification means that an adequate distance to the sensor must be observed.

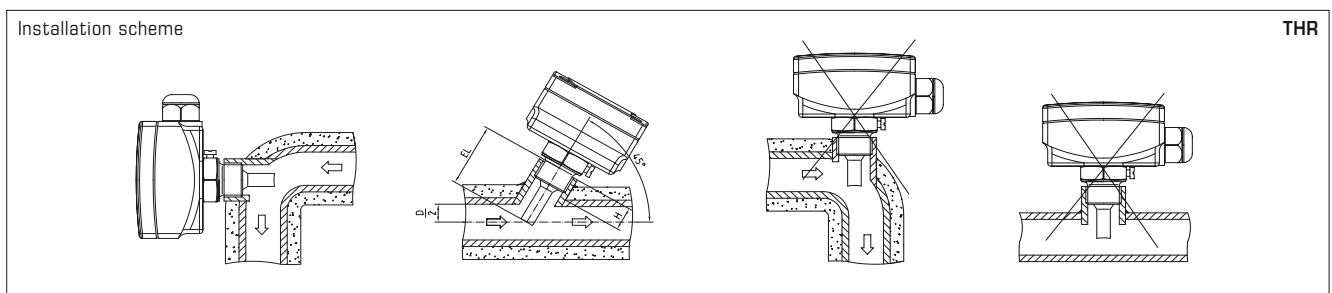
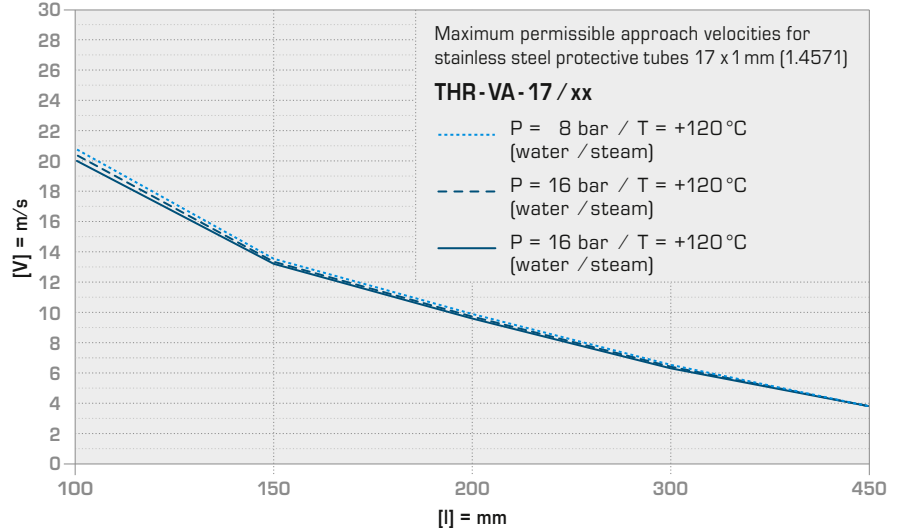
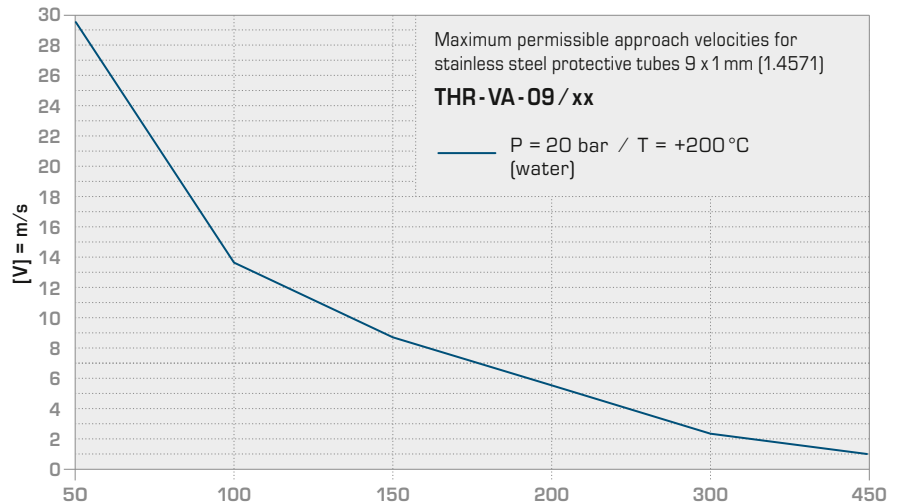
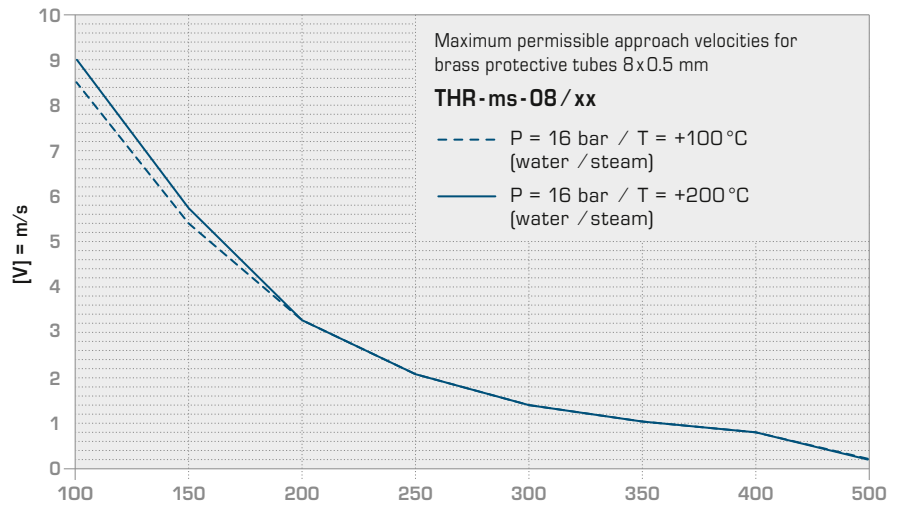
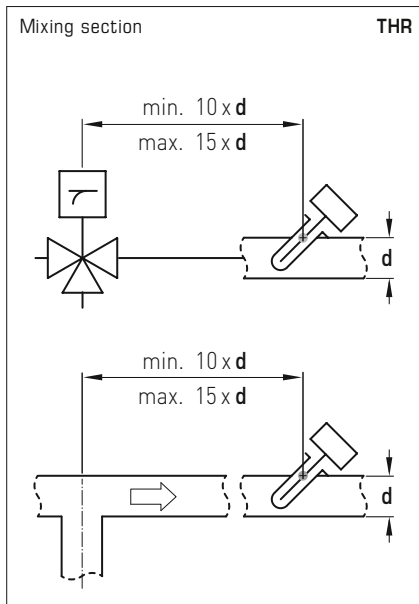

## THERMASGARD® THE

Immersion sleeves made of stainless steel or brass, nickel-plated, with adjusting screw, for sleeve sensor HTF/HFTM

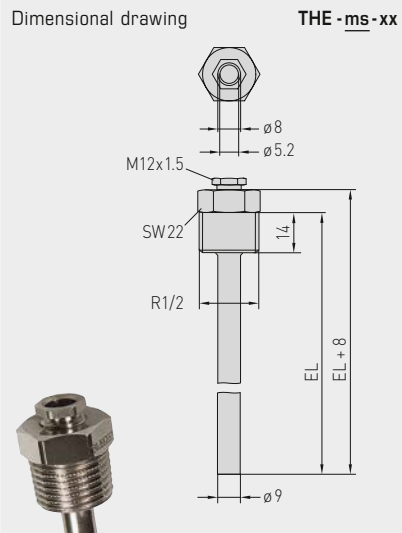

### THE -ms-xx

Immersion sleeve, nickel-plated brass

with adjusting screw, thread-sealing, conical, according to DIN 10226

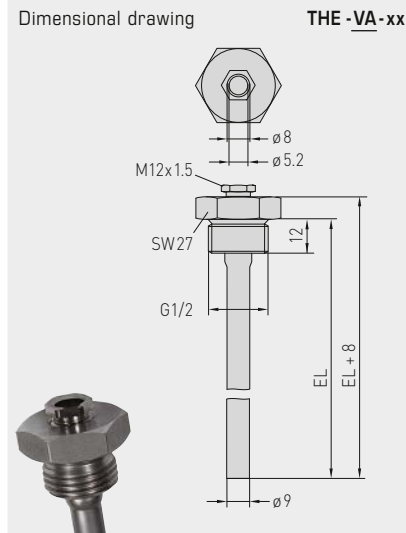

### THE -VA-xx

Immersion sleeve, stainless steel V4A (1.4571)

with adjusting screw, flat sealing, cylindrical, according to DIN 228

#### When Copper and Zinc are Not Enough

Uncompromising quality and safety are also paramount in the design of the accessory from S+S. This is why our metal immersion sleeves for duct sensors are made using either nickel plated brass or stainless steel. Brass is an alloy consisting mainly of copper and zinc, which provide good forming and machining properties, mechanical strength, temperature resistance and electrical conductivity.

In contrast to conventional products in the market, however, our brass immersion sleeves feature an additional nickel coating. This ensures their longterm corrosion resistance in minor aggressive media, from air and water to alkaline solutions and diluted acids. At the same time, the nickel layer prevents ingredients in thermally conductive compounds from stripping the copper and causing pitting.

Highest protection against corrosion is provided by immersion sleeves made of stainless steel. Among the available qualities, we chose VA 1.4571 or AISI 316 Ti, a high-grade austenite specialty combining chromium, nickel and molybdenum with an extra titanium content. The alloy has a proven fit particularly in the design of chemical process equipment and technical instruments as well as in waste gas and water treatment. Its corrosion resistance also includes chlorides or salts and more aggressive acids, such as hydrochloric acid (HCl).

#### THERMASGARD® THE Immersion sleeve Ø 9 mm for THERMASGARD® HTF / HFTM

Type / WG01	p <sub>max</sub> static	T <sub>max</sub>	Inserted Length (EL)	Item No.	Price
<b>THE -ms / xx</b>	<b>Brass nickel-plated</b>			<b>Ø 9 x 1,0 mm</b>	
THE-MS 50MM	16 bar	+130 °C	50 mm	7100-0011-6010-002	9,96 €
THE-MS 100MM	16 bar	+130 °C	100 mm	7100-0011-6020-002	10,76 €
THE-MS 150MM	16 bar	+130 °C	150 mm	7100-0011-6030-002	11,16 €
THE-MS 200MM	16 bar	+130 °C	200 mm	7100-0011-6040-002	11,94 €
THE-MS 250MM	16 bar	+130 °C	250 mm	7100-0011-6050-002	13,38 €
<b>THE -VA / xx</b>	<b>Stainless steel V4A (1.4571)</b>			<b>Ø 9 x 1,0 mm</b>	
THE-VA 50MM	40 bar	+200 °C	50 mm	7100-0012-6010-002	19,71 €
THE-VA 100MM	40 bar	+200 °C	100 mm	7100-0012-6020-002	21,77 €
THE-VA 150MM	40 bar	+200 °C	150 mm	7100-0012-6030-002	23,38 €
THE-VA 200MM	40 bar	+200 °C	200 mm	7100-0012-6040-002	24,66 €
THE-VA 250MM	40 bar	+200 °C	250 mm	7100-0012-6050-002	30,65 €
THE-VA 300MM	40 bar	+200 °C	300 mm	7100-0012-6060-002	32,02 €
THE-VA 400MM	40 bar	+200 °C	400 mm	7100-0012-6080-002	33,06 €

Ordering example: THE -ms - 150 (Brass immersion sleeve, Ø = 9 mm, EL = 150 mm)  
 THE -VA - 150 (Stainless steel immersion sleeve, Ø = 9 mm, EL = 150 mm)  
 Other inserted lengths on request

Note: inner diameter of socket 5.2 mm, with adjusting screw M12 x 1.5

**INSTRUCTIONS FOR PLANNING AND INSTALLATION**

The approaching flow causes the protective tube to vibrate.

If the specified approach velocity is exceeded even by a marginal amount, a negative impact on the protective tube's service life may result (material fatigue).

Please observe permissible approach velocities for stainless steel protective tubes (see graph **THE-VA**) as well as for brass protective tubes (see graph **THE-ms**).

Discharge of gases and pressure surges must be avoided as they have a negative influence on the service life and may damage the protective tubes irreparably.

**MIXING SECTION**

After the mixing of water flows of different temperatures, the issue of temperature stratification means that an adequate distance to the sensor must be observed.

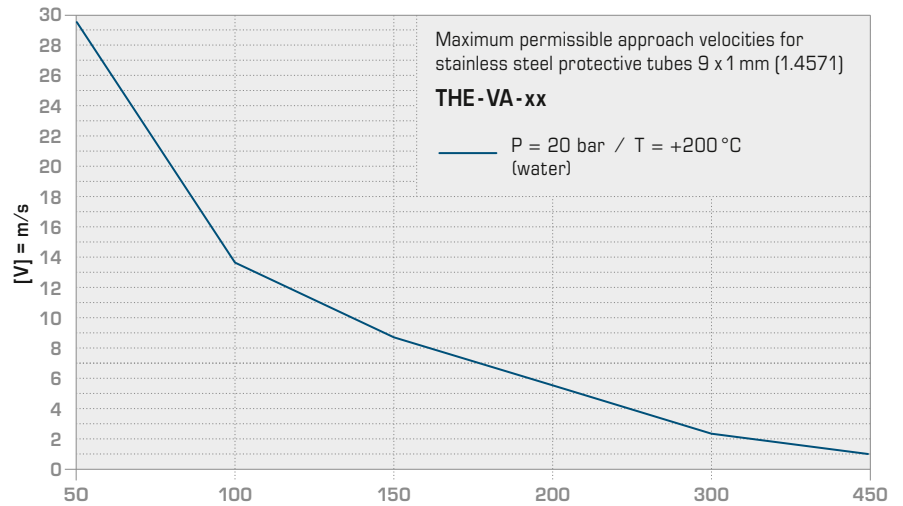
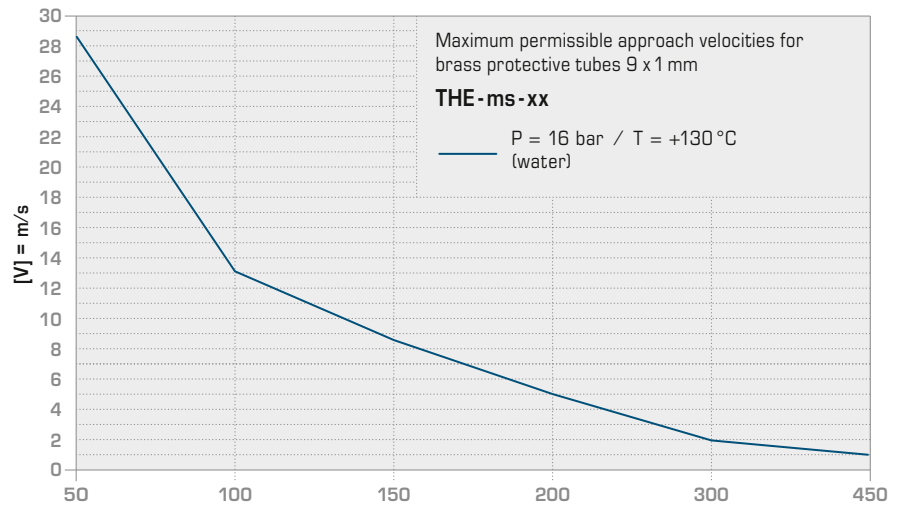
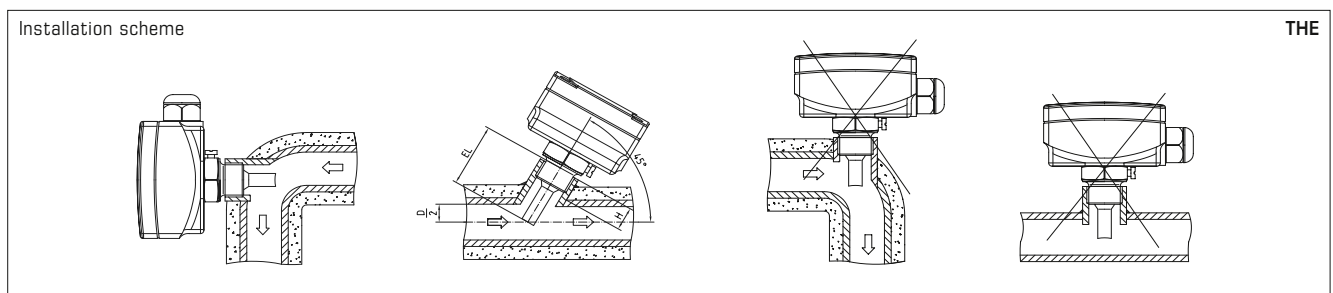
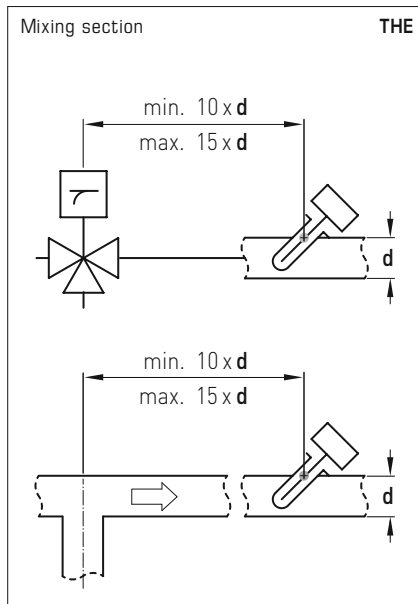



Mounting flange, plastic  
Capillary tube gland bracket

Dimensional drawing **MF-06-K**

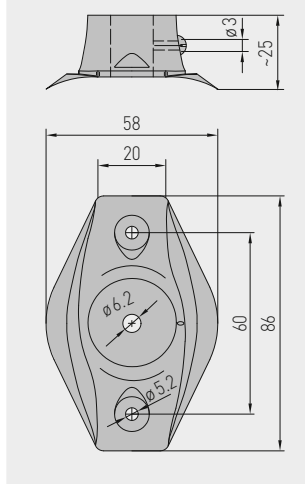

**MF-06-K**

Mounting flange, plastic



Dimensional drawing **MF-15-K**

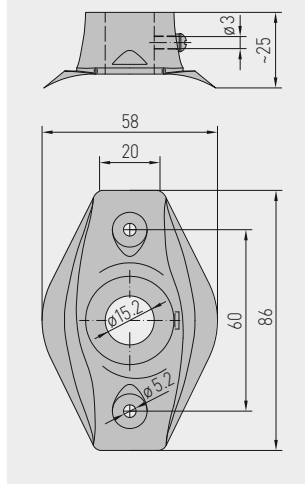

**MF-15-K**

Mounting flange, plastic



Dimensional drawing **MFT-20-K**

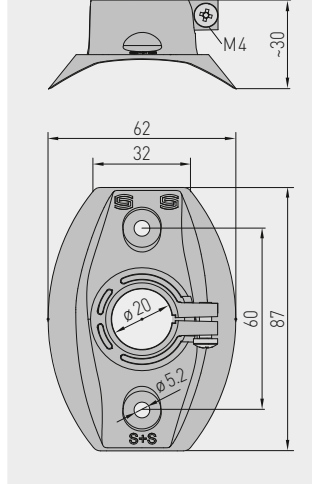

**MFT-20-K**

Mounting flange, plastic



Dimensional drawing **KRD-04**

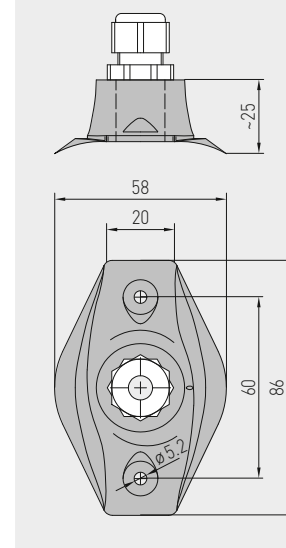

**KRD-04**

Capillary tube gland bracket, plastic



Type/WG01	Mounting flange, plastic	Tube Gland	T <sub>max</sub>	Item No.	Price
MF-xx-K	for metal protective tubes!				
<b>MF-06-K</b>	Mounting flange, plastic, approx. 58 x 86 x 25 mm for rod sensors <b>MWTF/MWTM</b>	Ø 6.2 mm	+100 °C	7100-0030-1000-000	<b>5,83 €</b>
<b>MF-10-K</b>	Mounting flange, plastic, approx. 58 x 86 x 25 mm for duct air flow monitors <b>KLGF/KLSW</b>	Ø 10.2 mm	+100 °C	7100-0031-1000-000	<b>9,10 €</b>
<b>MF-14-K</b>	Mounting flange, plastic, approx. 58 x 86 x 25 mm for duct humidity sensors <b>KFF/KFTF</b> and pendulum room humidity sensors <b>RPFF/RPFTF</b> as well as for duct air flow monitors <b>KLGF/KLSW</b>	Ø 14.2 mm	+100 °C	7100-0030-2000-000	<b>9,10 €</b>
<b>MF-15-K</b>	Mounting flange, plastic, approx. 58 x 86 x 25 mm for temperature sensors <b>TF</b> (series Tyr 1) and temperature measuring transducers <b>TM</b> (series Tyr 1)	Ø 15.2 mm	+100 °C	7100-0032-0000-000	<b>5,83 €</b>
<b>MF-20-K</b>	Mounting flange, plastic, approx. 58 x 86 x 25 mm for duct sensors <b>KH</b>	Ø 20.2 mm	+100 °C	7100-0030-4000-000	<b>9,10 €</b>
<b>MFT-20-K</b>	for <b>PLEUROFORM</b> multi-channel pipes!				
<b>MFT-20-K</b>	Mounting flange, plastic, approx. 62 x 87 x 30 mm for duct sensors (series Tyr 1 / Tyr 2)	Ø 20 mm	+100 °C	7000-0031-0000-000	<b>9,10 €</b>

Type/WG01	Capillary tube gland bracket	Item No.	Price
<b>KRD-04</b>	Capillary tube gland bracket, plastic, approx. 58 x 86 x 25 mm (M 16 x 1.5) for frost protection thermostats (e.g. for air ducts) and rod sensors <b>MWTF/MWTM</b>	7100-0030-7000-000	<b>8,49 €</b>

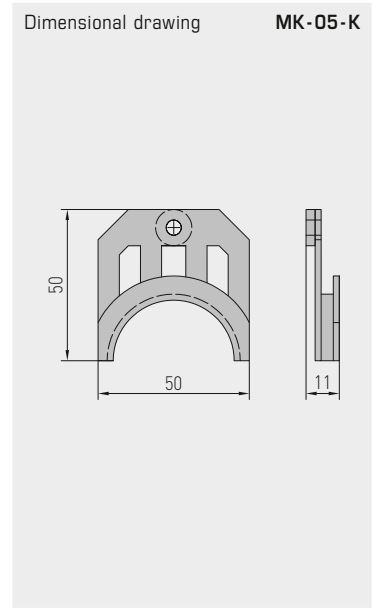
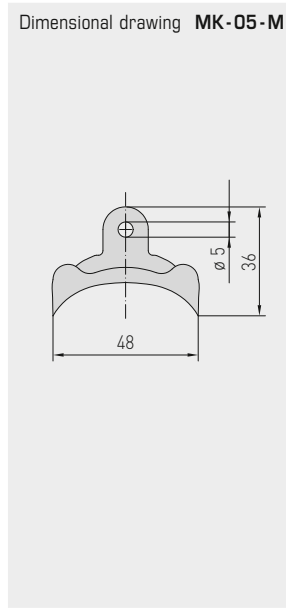
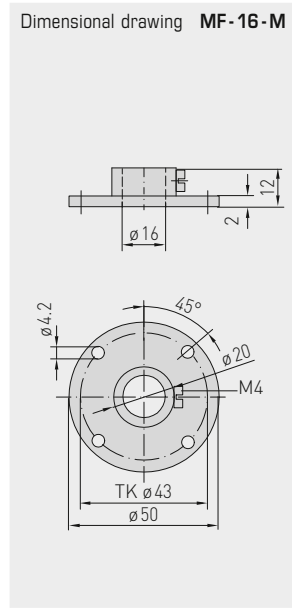
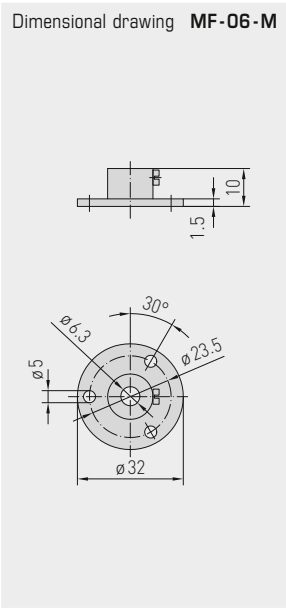

**MF-06-M**

Mounting flange, metal



**MF-16-M**

Mounting flange, metal



**MK-05-M**

Galvanised steel mounting clamps



**MK-05-K**

Mounting clamps, plastic



Type / WG01	Mounting flange, metal	Tube Gland	T <sub>max</sub>	Item No.	Price
MF-xx-M	for metal protective tubes!				
<b>MF-06-M</b>	Mounting flange, metal (galvanised steel), Ø 32 mm, for temperature sensors <b>TF</b> (form B) temperature measuring transducers <b>TM</b> (form B), rod sensors <b>MWTF/MWTM</b>	Ø 6.3 mm	+700 °C	7100-0030-5000-100	<b>9,10 €</b>
<b>MF-16-M</b>	Mounting flange, metal (galvanised steel), Ø 50 mm, for duct humidity sensors <b>KFF/KFTF</b> and pendulum room humidity sensors <b>RPFF/RPFTF</b>	Ø 16.0 mm	+700 °C	7100-0030-6020-000	<b>30,06 €</b>

Type / WG01	Mounting clamps	Item No.	Price
<b>MK-05-M</b>	Galvanised steel <b>mounting clamps</b> (6 pieces) for rod sensors <b>MWTF/MWTM</b>	7100-0034-0000-000	<b>9,41 €</b>
<b>MK-05-K</b>	Plastic <b>mounting clamps</b> (6 pieces) for frost protection thermostats	7100-0034-1000-000	<b>9,41 €</b>

Mounting accessories  
for Immersion sensor

Dimensional drawing **ESSH**

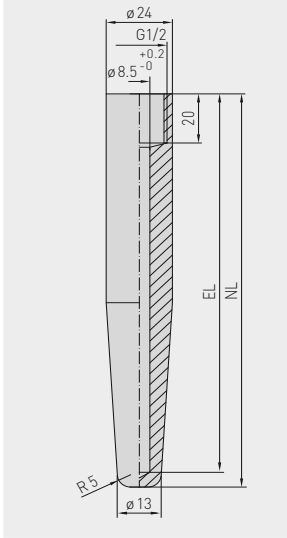

**ESSH**

Welding protective sleeve



Dimensional drawing **KVSS**

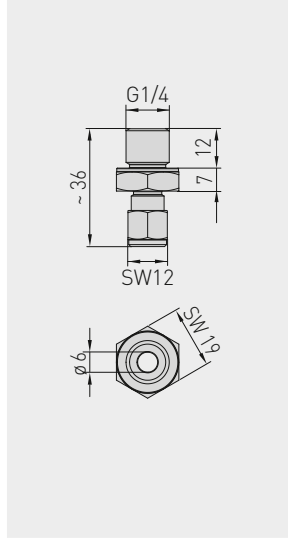

**KVSS**

Clamp union with cutting ring



Dimensional drawing **KVST**

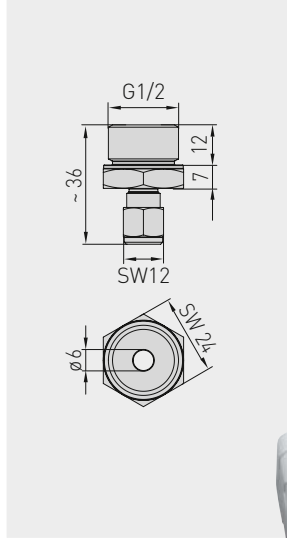

**KVST**

Clamp union with clamp ring

Dimensional drawing **TH-ADAPTER-HW**

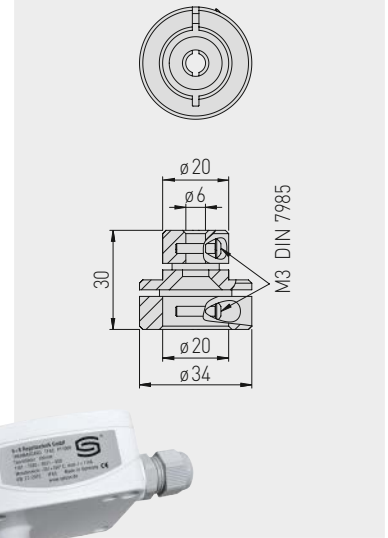

**TH-ADAPTER-HW**

Immersion sleeve adapter, metal

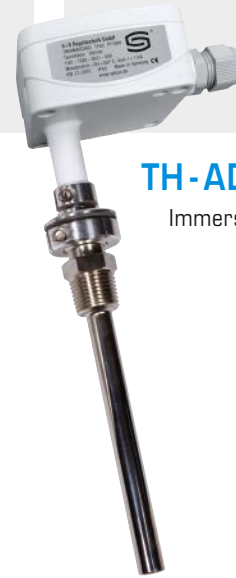

Type / WG01	Welding protective sleeve	Item No.	Price
	Welding protecting sleeves, G 1/2" straight internal pipe thread, stainless steel <b>V4A</b> (1.4571), other materials on request,		
<b>ESSH 100MM</b>	for immersion sleeves (EL) = 100 mm, P <sub>max</sub> = 100 bar	7100-0052-0020-001	<b>65,59 €</b>
<b>ESSH 150MM</b>	for immersion sleeves (EL) = 150 mm, P <sub>max</sub> = 100 bar	7100-0052-0030-001	<b>75,30 €</b>
<b>ESSH 200MM</b>	for immersion sleeves (EL) = 200 mm, P <sub>max</sub> = 100 bar	7100-0052-0040-001	<b>84,99 €</b>

Type / WG01	Clamp union	Item No.	Price
<b>KVST</b>	Clamp union with clamp ring PTFE, Ø 6 mm	7100-0032-0110-000	<b>93,31 €</b>
<b>KVSS</b>	Clamp union with cutting ring VA, Ø 6 mm	7100-0032-1000-000	<b>60,13 €</b>

Type / WG01	Immersion sleeve adapter, metal	Item No.	Price
<b>TH-ADAPTER-HW</b>	Metal immersion sleeve adapter (adaptation Ø 20 mm / Ø 6 mm) for mounting S+S temperature sensors from the TF and TM series in immersion sleeves by Honeywell / CentraLine of the types VFFT, VFL, VFNT, VFLN	7100-0037-0001-000	<b>14,75 €</b>

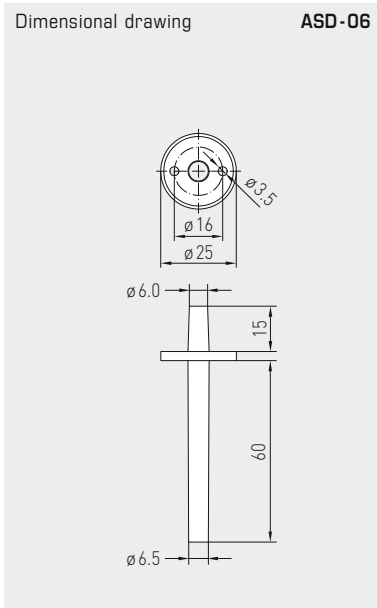

**ASD-06**

Connection set  
(straight nipples)

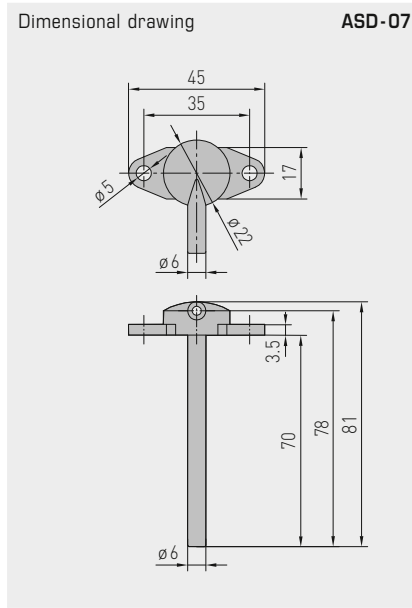

**ASD-07**

Connection nipples  
(at 90 degree angle)

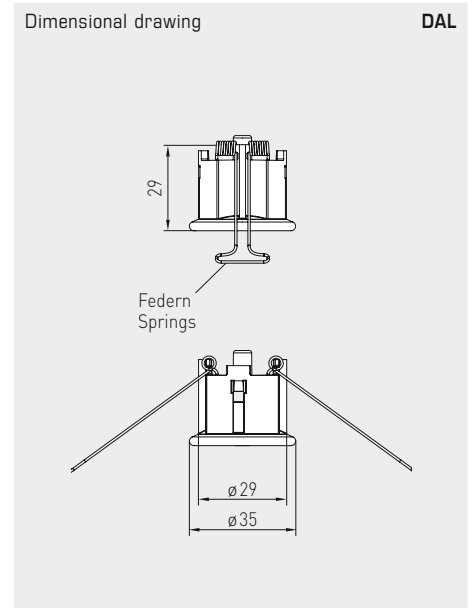

**DAL**

Pressure outlet

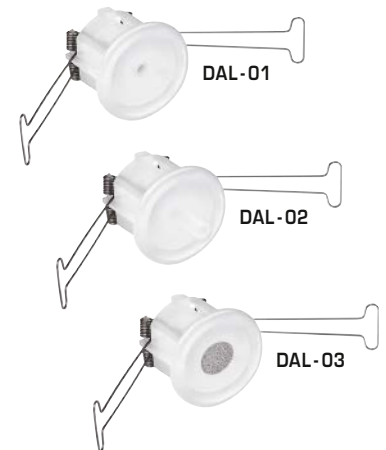

Type / WG01	Accessories for differential pressure switches	Item No.	Price
<b>ASD-06</b>	Connection set consisting of 2 connection nipples (straight) made of ABS, 2 m PVC hose (soft, UV-resistant), 4 Philips head screws (no pre-drilling required)	7100-0060-3000-000	<b>7,28 €</b>
<b>ASD-07</b>	2 connection nipples (at 90 degree angle) made of ABS	7100-0060-7000-000	<b>7,28 €</b>
<b>ASS-UV 100M</b>	Connecting hose, UV-resistant, Ø 6mm, 1 roll (100m)	7100-0060-3101-000	<b>1541,28 €</b>
<b>DAL-01</b>	Pressure outlet for ceiling and in-wall installation as a pressure reference point	7300-0060-3000-001	<b>34,07 €</b>
<b>DAL-02</b>	for hose attachment	7300-0060-3000-100	<b>34,07 €</b>
<b>DAL-03</b>	as a pressure reference point, with sinter filter made of stainless steel V4A (1.4404)	7300-0060-3000-200	<b>63,80 €</b>

Type / WG01	Accessories for differential pressure switches DS1, DS2	Item No.	Price
<b>DS-MW-Z</b>	Sheet steel mounting angle in Z-Form	7100-0063-0000-000	<b>12,72 €</b>
<b>DS-MW-L</b>	Sheet steel mounting angle in L-Form	7100-0063-1000-000	<b>13,02 €</b>
<b>DS-MW-U</b>	Sheet steel mounting angle in U-Form	7100-0060-9000-000	<b>16,01 €</b>

Protection hoods

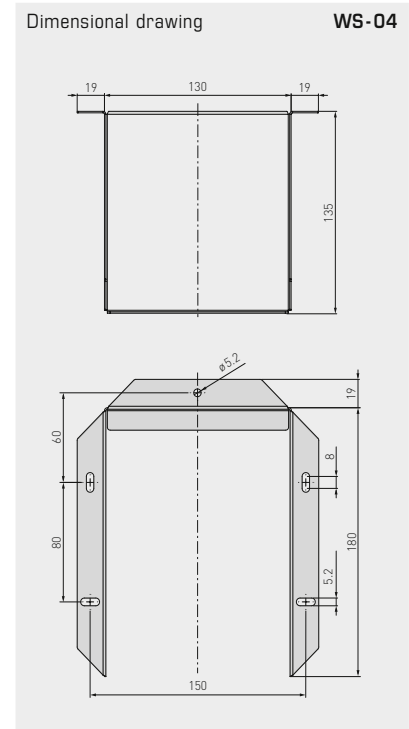
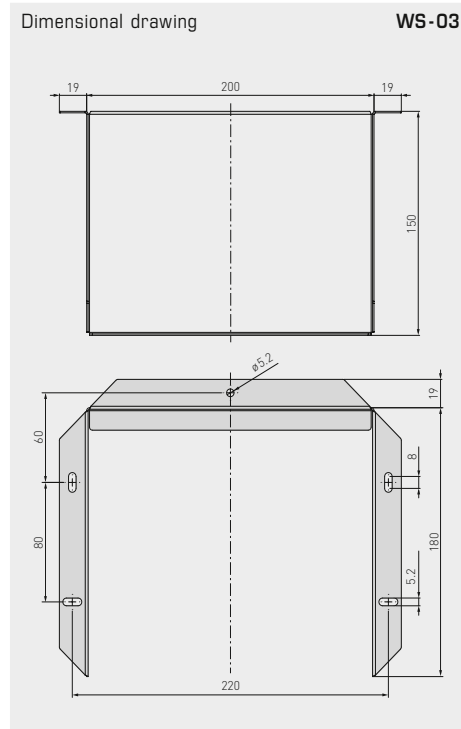
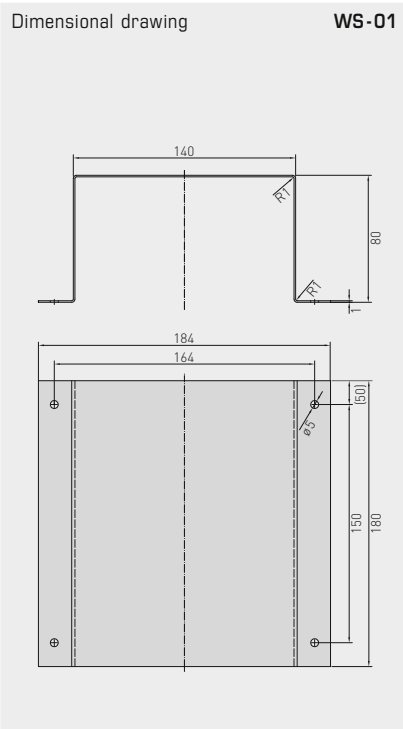

**WS-01**  
Sun and ball-impact protection hood

**WS-03**  
Weather and sun protection hood

**WS-04**  
Weather and sun protection hood

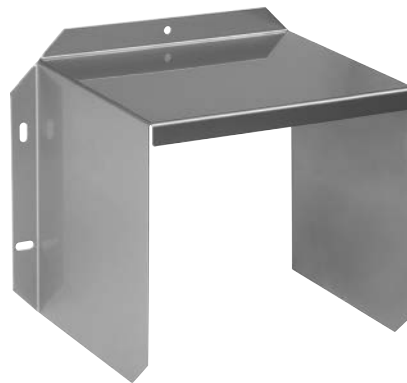
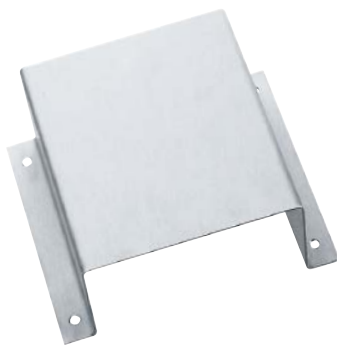

Type / WG01	Protection hoods	Item No.	Price
WS-01	Sun and ball-impact protection hood, 184 x 180 x 80 mm, stainless steel V2A (1.4301)	7100-0040-2000-000	30,26 €
WS-03	Weather and sun protection hood, 200 x 180 x 150 mm, stainless steel V2A (1.4301)	7100-0040-6000-000	42,61 €
WS-04	Weather and sun protection hood, 130 x 180 x 135 mm, stainless steel V2A (1.4301)	7100-0040-7000-000	35,70 €



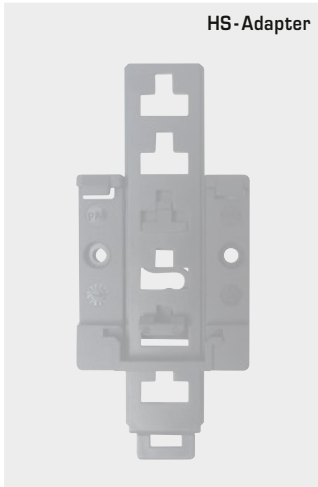

HS-Adapter

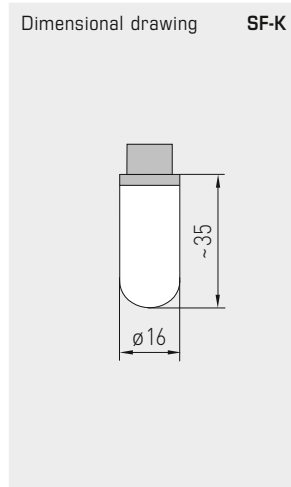

Dimensional drawing SF-K

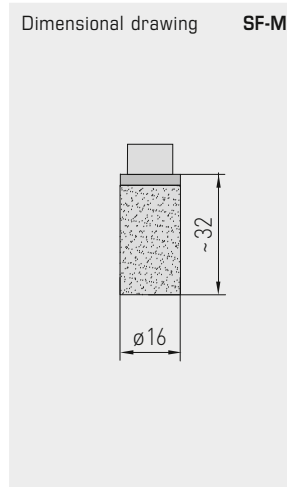

Dimensional drawing SF-M

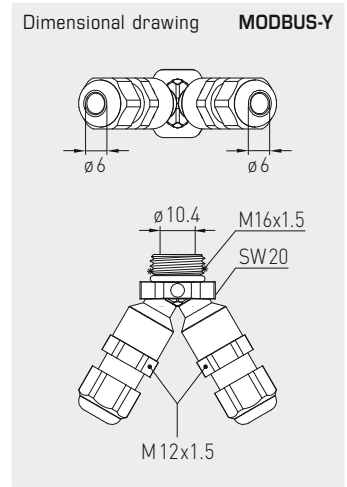

Dimensional drawing MODBUS-Y

### HS-Adapter

Universal holder for small housing on top-hat rails

### SF-K

Plastic sinter filter

### SF-M

Metal sinter filter

### MODBUS-Y

Y-Adapter als Bypass für Busanschluss



Type / WG01	Spare parts, small parts and special accessories	Item No.	Price
SF-K	Plastic sinter filter, Ø 16 mm, L = 35 mm, exchangeable for humidity sensors	7000-0050-2310-000	12,25 €
SF-M	Metal sinter filter, Ø 16 mm, L = 32 mm, exchangeable, stainless steel V4A (1.4404) for humidity sensors	7000-0050-2200-100	40,31 €
PSW-09	1 set of stainless steel paddles 1-8" (4 pieces), 29 x 34/60/89/157 mm for flow monitors SW	7700-0010-1000-000	18,30 €
PWFS-08	Stainless steel vane for vane switch WFS	7700-0010-2000-000	17,72 €
WH-20	Wall bracket for duct hygrometers KH	1200-0010-4000-000	11,88 €
HS-ADAPTER	Universal holder for small housings made from plastic PA6, black, for installation on 35mm top-hat rails, incl. fixing screws	7100-0038-0000-000	21,23 €
SPB1	Strap for surface-contact sensors	7100-0035-0000-000	3,60 €
WLP-1	Heat-conductive paste, silicone-free (2 ml)	7100-0060-1000-000	3,22 €
MODBUS-Y	Y-adapter for cable gland M16x 1.5 (on 2x M12x 1.5), made of plastic	7000-0005-0002-100	10,02 €

**Special accessories for M12 connector**

5-pin / 12-pin, A coded,

Circular connector with screw-locking according to DIN EN 61076-2-101

**AL xx**

Connecting cable with cable socket



**VL xx**

Interconnecting cable with cable socket and cable connector



**KB xx**

Cable socket without cable



Connecting cable for M12 connector	Type / WG011	Cable length	Item No.	Price
PVC cable, <b>5-pin, shielded</b> , with cable socket (M12, A coded, female), approx. Ø = 15 mm, L = 35 mm, and one open cable end	<b>ALG xx A5F</b>		<b>5-pin, shielded</b>	
	ALG M12-A5F PVC 2M	2 m	2000-9121-0000-031	26,13 €
	ALG M12-A5F PVC 5M	5 m	2000-9121-0000-041	33,50 €
	ALG M12-A5F PVC 10M	10 m	2000-9121-0000-051	46,13 €
PVC cable, <b>5-pin, unshielded</b> , with cable socket (M12, A coded, female), approx. Ø = 15 mm, L = 35 mm, and one open cable end	<b>AL xx A5F</b>		<b>5-pin, unshielded</b>	
	AL M12-A5F PVC 2M	2 m	2000-9121-0000-001	16,73 €
	AL M12-A5F PVC 5M	5 m	2000-9121-0000-011	20,70 €
	AL M12-A5F PVC 10M	10 m	2000-9121-0000-021	26,95 €
PVC cable, <b>12-pin, unshielded</b> , with cable socket (M12, A coded, female), approx. Ø = 15 mm, L = 35 mm, and one open cable end	<b>AL xx A12F</b>		<b>12-pin, unshielded</b>	
	AL M12-A12F PVC 2M	2 m	2000-9122-0000-001	53,78 €
	AL M12-A12F PVC 5M	5 m	2000-9122-0000-011	63,62 €
	AL M12-A12F PVC 10M	10 m	2000-9122-0000-021	80,28 €
Interconnecting cable for M12 connector	Type / WG011	Cable length	Item No.	Price
PVC cable, <b>5-pin, shielded</b> , with cable socket (M12, A coded, female) and cable connector (M12, A coded, male) approx. Ø = 15 mm, L = 35 mm	<b>VLG xx A5</b>		<b>5-pin, shielded</b>	
	VLG M12-A5 PVC 2M	2 m	2000-9111-0000-031	56,21 €
	VLG M12-A5 PVC 5M	5 m	2000-9111-0000-041	63,68 €
	VLG M12-A5 PVC 10M	10 m	2000-9111-0000-051	76,47 €
PVC cable, <b>5-pin, unshielded</b> , with cable socket (M12, A coded, female) and cable connector (M12, A coded, male) approx. Ø = 15 mm, L = 35 mm	<b>VL xx A5</b>		<b>5-pin, unshielded</b>	
	VL M12-A5 PVC 2M	2 m	2000-9111-0000-001	29,87 €
	VL M12-A5 PVC 5M	5 m	2000-9111-0000-011	33,79 €
	VL M12-A5 PVC 10M	10 m	2000-9111-0000-021	40,49 €
PVC cable, <b>12-pin, unshielded</b> , with cable socket (M12, A coded, female) and cable connector (M12, A coded, male) approx. Ø = 15 mm, L = 35 mm	<b>VL xx A12</b>		<b>12-pin, unshielded</b>	
	VL M12-A12 PVC 2M	2 m	2000-9112-0000-001	112,31 €
	VL M12-A12 PVC 5M	5 m	2000-9112-0000-011	123,34 €
	VL M12-A12 PVC 10M	10 m	2000-9112-0000-021	142,03 €
Mounting accessories for M12 connector	Type / WG02	Contact	Item No.	Price
Cable socket (M12, A coded, female), approx. Ø = 20 mm, L = 54 mm, unassembled, without cable	<b>KB xx</b>		<b>female</b>	
	KB M12-A5	5-pin	7100-0070-0712-000	22,02 €
	KB M12-A12	12-pin	7100-0070-0714-000	65,70 €
Cable connector (M12, A coded, male), approx. Ø = 20 mm, L = 54 mm, unassembled, without cable	<b>KS xx</b>		<b>male</b>	
	KS M12-A5	5-pin	7100-0070-0716-000	22,02 €
	KS M12-A12	12-pin	7100-0070-0718-000	65,70 €



**NEW**

S+S REGELTECHNIK

Special accessories for M8 connector  
4-pin, EtherCATP coded,  
for industrial EtherCATP applications

### ALG ECATP xx

Connecting cable  
with one cable connector



### VLG ECATP xx

Interconnecting cable  
with two cable connectors



EtherCATP



Connecting cable for EtherCATP	Type / WG02	Cable length	Item No.	Price
PUR cable, 4-pin, shielded, with one cable connector (MB, EtherCATP coded) and one open cable end	<b>ALG ECATP xx</b>		<b>shielded</b>	
	ALG ECATP 0.5m	0.5 m	2000-9131-0000-001	37,67 €
	ALG ECATP 1m	1.0 m	2000-9131-0000-011	41,09 €
	ALG ECATP 2m	2.0 m	2000-9131-0000-021	44,40 €
	ALG ECATP 5m	5.0 m	2000-9131-0000-031	67,41 €

Interconnecting cable for EtherCATP	Type / WG02	Cable length	Item No.	Price
PUR cable, 4-pin, shielded, with two cable connectors (MB, EtherCATP coded)	<b>VLG ECATP xx</b>		<b>shielded</b>	
	VLG ECATP 0.5m	0.5 m	2000-9131-0000-041	60,51 €
	VLG ECATP 1m	1.0 m	2000-9131-0000-051	63,55 €
	VLG ECATP 2m	2.0 m	2000-9131-0000-061	71,25 €
	VLG ECATP 5m	5.0 m	2000-9131-0000-071	93,98 €

## Optional services

Individual components / WGO1	Item No.	Price
FET	7100-0022-4000-000	<b>48,50 €</b>
KTY 81-210	7100-0022-0000-000	<b>4,60 €</b>
LM235Z (TCR = 10 mV/K; 2.73 V at 0°C), KP10	7100-0022-1000-000	<b>7,39 €</b>
NI1000 (according to DIN EN 43760, class B, TKR = 6180 ppm/K)	7100-0020-9000-000	<b>8,79 €</b>
NI1000TK5000 (according to DIN EN 43760, class B, TKR = 5000 ppm/K), LG-Ni 1000	7100-0021-0000-000	<b>12,37 €</b>
NTC 1,8 KOHM NTC 1.8 K	7100-0021-2000-001	<b>10,80 €</b>
NTC 10 KOHM PRECON NTC 10 K Precon	7100-0021-9000-000	<b>5,65 €</b>
NTC 20 KOHM NTC 20 K	7100-0021-6000-000	<b>5,65 €</b>
NTC 30 KOHM NTC 30 K	7100-0021-7000-000	<b>5,65 €</b>
NTC 50 KOHM NTC 50 K	7100-0021-8000-000	<b>5,65 €</b>
PT100 KLASSE B (according to DIN EN 60751, class B)	7100-0020-1000-000	<b>6,79 €</b>
PT100 1/2 DIN (according to DIN EN 60751, class A)	7100-0020-2000-000	<b>9,03 €</b>
PT100 1/3 DIN (according to DIN EN 60751, class A)	7100-0020-3000-000	<b>10,50 €</b>
PT1000 KLASSE B (according to DIN EN 60751, class B)	7100-0020-5000-000	<b>9,16 €</b>
PT1000 1/2 DIN (according to DIN EN 60751, class A)	7100-0020-6000-000	<b>10,37 €</b>
PT1000 1/3 DIN (according to DIN EN 60751, class A)	7100-0020-7000-000	<b>12,07 €</b>
PT1000 1/10 DIN (according to DIN EN 60751, class AA)	7100-0020-8000-000	<b>37,78 €</b>
Note:	Other sensors on request.	

Optional services / WGO1	Unit	Price
Double sensor	<b>plus 50 %</b> of instrument price	
1 / 2 DIN (according to DIN EN 60751, class A)	Per piece	<b>7,01 €</b>
1 / 3 DIN (according to DIN EN 60751, class A)	Per piece	<b>7,01 €</b>
1 / 10 DIN (according to DIN EN 60751, class AA)	Per piece	<b>28,00 €</b>
Connection type	<b>4-wire connection</b> with ceramic base, head form B	Per piece <b>5,83 €</b>
	<b>4-wire connection</b> with circuit board, box head	Per piece <b>3,50 €</b>
Protection class	<b>IP 65</b> at head form B	Per piece <b>8,99 €</b>
	<b>IP 68</b> (Sensor sleeve watertight compound-filled) for cable sensors	Per piece <b>3,24 €</b>



Custom-made products (for 25 or more pieces)		Unit	Price
<b>Silicone-free sensor production</b>		Per piece	on request!
<b>Factory test certificate</b> (per device)	1-point certificate	One-time cost	on request!
	2-point certificate	One-time cost	on request!
	3-point certificate	One-time cost	on request!
	Each additional test point	One-time cost	on request!
<b>Custom-made products</b>	Setup costs for custom-made products	One-time cost	on request!
<b>Special paintwork</b>	Set-up costs for special paintwork	one-off (net)	<b>180,66 €</b>
	plus costs for special paintwork	<b>from 25 piece</b> per piece	<b>17,40 €</b>
		<b>from 50 piece</b> per piece	<b>12,65 €</b>
<b>Special print</b> (with stereotype)	Set-up costs incl. stereotype production, <b>1 colour</b>	one-off (net)	<b>180,66 €</b>
	Set-up costs incl. stereotype production, <b>2 colour</b>	one-off (net)	<b>276,64 €</b>
	plus costs for special print	<b>from 25 piece</b> per piece / colour	<b>10,96 €</b>
		<b>from 50 piece</b> per piece / colour	<b>7,40 €</b>
		<b>from 100 piece</b> per piece / colour	<b>5,94 €</b>
		<b>from 250 piece</b> per piece / colour	<b>4,51 €</b>
<b>Printing customer logo on housing cover</b> (for 200 covers of one housing series)	Setup costs for printing on housing cover	One-time cost	on request!
	Plus printing costs, 2-colour, printing on housing cover	Per piece	on request!
<b>Labelling with customer logo</b>	Setup costs for labelling	One-time cost	on request!
	Plus costs for labelling	Per piece	on request!

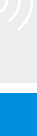
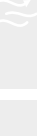
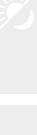
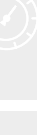
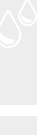

**Conversion table -  
Anglo-American units of measurement**
**TEMPERATURE**

<b>Fahrenheit</b>	<b>°F → °C</b> (°F - 32) ÷ 1.8 = (°C)	<b>°C → °F</b> (°C x 1.8) + 32 = (°F)
-------------------	--	--

**LENGTH**

Inches	<b>"/inch → mm</b> ("/inch) × 25.4 = (mm)	<b>mm → "/inch</b> (mm) ÷ 25.4 = ("/inch)
Feet	<b>ft → m</b> (ft) × 0.3048 = (m)	<b>m → ft</b> (m) ÷ 0.3048 = (ft)
Yards	<b>yd → m</b> (yd) × 0.9144 = (m)	<b>m → yd</b> (m) ÷ 0.9144 = (yd)
Miles	<b>mi → km</b> (mi) × 1.609344 = (km)	<b>km → mi</b> (km) ÷ 1.609344 = (mi)

**AREA**

Square inches	<b>in<sup>2</sup> → mm<sup>2</sup></b> (in <sup>2</sup> ) × 645.16 = (mm <sup>2</sup> )	<b>mm<sup>2</sup> → in<sup>2</sup></b> (mm <sup>2</sup> ) ÷ 645.16 = (in <sup>2</sup> )
	<b>in<sup>2</sup> → cm<sup>2</sup></b> (in <sup>2</sup> ) × 6.4516 = (cm <sup>2</sup> )	<b>cm<sup>2</sup> → in<sup>2</sup></b> (cm <sup>2</sup> ) ÷ 6.4516 = (in <sup>2</sup> )
Square feet	<b>ft<sup>2</sup> → m<sup>2</sup></b> (ft <sup>2</sup> ) × 0.09290304 = (m <sup>2</sup> )	<b>m<sup>2</sup> → ft<sup>2</sup></b> (m <sup>2</sup> ) ÷ 0.09290304 = (ft <sup>2</sup> )
Square yards	<b>yd<sup>2</sup> → m<sup>2</sup></b> (yd <sup>2</sup> ) × 0.83612736 = (m <sup>2</sup> )	<b>m<sup>2</sup> → yd<sup>2</sup></b> (m <sup>2</sup> ) ÷ 0.83612736 = (yd <sup>2</sup> )

**VOLUME**

Cubic inches	<b>in<sup>3</sup> → cm<sup>3</sup></b> (in <sup>3</sup> ) × 16.387064 = (cm <sup>3</sup> )	<b>cm<sup>3</sup> → in<sup>3</sup></b> (cm <sup>3</sup> ) ÷ 16.387064 = (in <sup>3</sup> )
Cubic feet	<b>ft<sup>3</sup> → m<sup>3</sup></b> (ft <sup>3</sup> ) × 0.028316846592 = (m <sup>3</sup> )	<b>m<sup>3</sup> → ft<sup>3</sup></b> (m <sup>3</sup> ) ÷ 0.028316846592 = (ft <sup>3</sup> )
Cubic yards	<b>yd<sup>3</sup> → m<sup>3</sup></b> (yd <sup>3</sup> ) × 0.764554857984 = (m <sup>3</sup> )	<b>m<sup>3</sup> → yd<sup>3</sup></b> (m <sup>3</sup> ) ÷ 0.764554857984 = (yd <sup>3</sup> )
US Gallons	<b>Imp. gal. → dm<sup>3</sup></b> (Imp. gal.) × 4.54609 = (dm <sup>3</sup> )	<b>dm<sup>3</sup> → Imp. gal.</b> (dm <sup>3</sup> ) ÷ 4.54609 = (Imp. gal.)
US-Gallone	<b>US. liq. gal. → dm<sup>3</sup></b> (US. liq. gal.) × 3.785412 = (dm <sup>3</sup> )	<b>dm<sup>3</sup> → US. liq. gal.</b> (dm <sup>3</sup> ) ÷ 3.785412 = (US. liq. gal.)

**MASS**

Ounces	<b>oz. → g</b> (oz.) × 28.349523 = (g)	<b>g → oz.</b> (g) ÷ 28.349523 = (oz.)
Pounds	<b>lb. → kg</b> (lb.) × 0.45359237 = (kg)	<b>kg → lb.</b> (kg) ÷ 0.45359237 = (lb.)
British tons (long tons)	<b>tn. l. → kg</b> (tn. l.) × 1016.0469088 = (kg)	<b>kg → tn. l.</b> (kg) ÷ 1016.0469088 = (tn. l.)
US tons (short tons)	<b>tn. sh. → kg</b> (tn. sh.) × 907.18474 = (kg)	<b>kg → tn. sh.</b> (kg) ÷ 907.18474 = (tn. sh.)



Sensor type	Manufacturer *	RTF	ATF	TF 65 + MF-15-K	TF 65 + TH 08	ALTF	HTF
<b>10K3A1</b> NTC 10 kOhm	<b>Aquatrol</b>	●	●	●	●	●	●
	<b>Honeywell</b>	T 8120 B	T 7416 A T 7043 E	●	T 7106 A T 7043 F	T 7044 C	T 7076 D
	<b>Johnson</b>	●	●	TE - 6361 V TE - 636 GV-1	●	●	●
	<b>Satchwell</b>	●	DOT10K2 DOS10K2	DDT10K1	DWT10K1 DST10K1	●	●
	<b>Seachange</b>	SEN / PTR / ROM	SEN / PR / OAT	SEN / PR / DCT	SEN / PR / IMM	SEN / PR / CLP	SEN / FL
	<b>Trend</b>	TE - TS	TE - TO	TE - TD	TE - TI	TE - TC	●
<b>10K4A1</b> NTC 10 kOhm Precon	<b>Andover</b>	TTS - S Series	●	TT - O Series	TT - I Series	TT - ST	●
	<b>Delta Controls</b>	●	●	●	●	●	●
	<b>Siebe</b>	●	●	●	●	●	●
	<b>York (&lt; 40°C)</b>	●	●	●	●	●	●
<b>20K6A1</b> NTC 20 kOhm	<b>Honeywell</b>	T 7460 H T 7470 A DRF 20 - S RF 20 T 4712	AF 20 DAF 20 T 7416 A1022	LF 20	VF 20 T VF 20 NT VF 20 L VF 20 LN WPF 20 T 7425 A	VF 20 A WPF 20 A	KFT 20 KFT 20 B DKF 20
<b>PT 100</b> DIN EN 60 751 class B	<b>Sauter</b>	EGT430 / F011	●	EGT466 / F011 EGT447 / F011	●	●	EGT456 / F011
	<b>Serck</b>	●	●	●	●	●	●
	<b>Siemens / Landis &amp; Staefa</b>	QAA100 QAA 2010	QAC 2010	FK-TP / 200 QAM 2110	QAE 2110	QAD 2010	QAP 2010
<b>PT 1000</b> DIN EN 60 751 class B	<b>Honeywell</b>	T 7412	T 7416 A1014	T 7411	T 7413	T 7414	●
	<b>Sauter</b>	EGT430 / F101	EGT401 / F101	EGT446 / F101 EGT447 / F101	-	EGT411 / F101	EGT456 / F101
	<b>Serck</b>	●	●	●	●	●	●
	<b>Siebe</b>	TS - 5811	●	●	●	●	●
	<b>Cylon</b>	●	●	●	●	●	●
<b>Ni 1000</b> DIN EN 43 760	<b>Sauter</b>	EGT 330 / F101	EGT 301 / F101	EGT 346 / F101 EGT 347 / F101 EGT 348 / F101	EGT 346 / F101 EGT 347 / F101 EGT 348 / F101	EGT 311 / F101	EGT 354 / F101 EGT 356 / F101
<b>Ni 1000 / TCR</b> Ni1000 TK500	<b>Siemens / Landis &amp; Staefa</b>	QAA 24 QAA 25 QAA 26 QAA 27 QAA 64	QAC 22	QAM 2120	QAE 2120	QAD 22 QAD 26	QAP 21 QAP 22 QAZ 21
<b>SAT 1</b>	<b>Satchwell</b>	DRT DU, DUS, DUSF	DOT 0002 DOS 0002	DDT 0001	DWT 0001 DST 0001	●	DDU
<b>FeT (T1)</b>	<b>Landis &amp; Staefa</b>	QAA 2040 FR - T1	FW - T1	QAM 2140 FK - T1	QAE 2140 FT - T1	FA - T1	QAP 2040 FTK - T1
<b>TAC 1</b> NTC 1.8 kOhm	<b>TAC Schneider</b>	●	●	●	●	●	●
<b>2.2 K3 A1</b> NTC 2.2 kOhm	<b>Ambiflex</b>	RTN 3060	ETN 3060	DTN 3060	ITN 3060	CTN 3060	●
	<b>Johnson</b>	TE - 6344 P	TE - 6343 P	TE - 6341 P TE - 6341 V TE - 634 GV - 1	TE - 6342 P	-	-
<b>3 K3 A1</b> NTC 3 kOhm	<b>Alerton</b>	MS - 1000 Series TS - 1050	●	●	●	●	●
<b>3 K6 A1</b> NTC 30 kOhm	<b>Drayton</b>	A 701	A 702	●	A 703	A 704	●
<b>LM235Z (KP10)</b>	<b>Kieback &amp; Peter</b>	TR TD	TA TAD	TLS TLD	TV, TVD TDN, TVP	TAV TAVD	TEV TKV

\* Manufacturer names are brands and / or trademarks of the respective companies.

## Sensor type (+)

Thermistor elements with positive temperature coefficient -

Temperature ranges (temperature/resistance)

FeT (T1)		KTY81-210		LM235Z (KP10)		Ni 1000 according to DIN EN 43760 TCR= 6180ppm/K		Ni 1000- TK 5000 (LG-Ni 1000) TCR= 5000ppm/K		PT 100 according to DIN EN 60751 TCR= 3850ppm/K		PT 1000 according to DIN EN 60751 TCR= 3850ppm/K	
°C	Ω	°C	Ω	°C	mV	°C	Ω	°C	Ω	°C	Ω	°C	Ω
-50	-	-50	1030	-50	-	-50	743	-50	790.8	-50	80.3	-50	803
-40	-	-40	1135	-40	2330	-40	791	-40	826.8	-40	84.3	-40	843
-30	1935	-30	1247	-30	2430	-30	842	-30	871.7	-30	88.2	-30	882
-20	2030	-20	1367	-20	2530	-20	893	-20	913.4	-20	92.2	-20	922
-15	2078	-15		-15	2580	-15	920	-15	934.7	-15	94.1	-15	941
-10	2027	-10	1495	-10	2630	-10	946	-10	956.2	-10	96.1	-10	961
-5	2176	-5		-5	2680	-5	973	-5	978.0	-5	98.0	-5	980
0	2226	0	1630	0	2730	0	1000	0	1000.0	0	100.0	0	1000
1	2236	1		1	2740	5	1028	1	1004.4	5	102.0	5	1020
2	2246	2		2	2750	10	1056	2	1008.9	10	103.9	10	1039
3	2256	3		3	2760	15	1084	3	1013.3	15	105.8	15	1058
4	2266	4		4	2770	20	1112	4	1017.8	20	107.8	20	1078
5	2276	5		5	2780	25	1142	5	1022.3	25	109.8	25	1098
6	2286	6		6	2790	30	1171	6	1026.7	30	111.7	30	1117
7	2298	7		7	2800	35	1200	7	1031.2	35	113.6	35	1136
8	2306	8		8	2810	40	1230	8	1035.8	40	115.5	40	1155
9	2316	9		9	2820	45	1261	9	1040.3	45	117.5	45	1175
10	2326	10	1772	10	2830	50	1291	10	1044.8	50	119.4	50	1194
11	2337	11		11	2840	55	1322	11	1049.3	55	121.3	55	1213
12	2347	12		12	2850	60	1353	12	1053.9	60	123.2	60	1232
13	2357	13		13	2860	65	1385	13	1058.4	65	125.2	65	1252
14	2367	14		14	2870	70	1417	14	1063.0	70	127.1	70	1271
15	2377	15		15	2880	75	1450	15	1067.6	75	129.0	75	1290
16	2388	16		16	2890	80	1483	16	1072.2	80	130.9	80	1309
17	2398	17		17	2900	85	1516	17	1076.8	85	132.8	85	1328
18	2408	18		18	2910	90	1549	18	1081.4	90	134.7	90	1347
19	2418	19		19	2920	95	1584	19	1086.0	95	136.6	95	1366
20	2429	20	1922	20	2930	100	1618	20	1090.7	100	138.5	100	1385
21	2439	21		21	2940	110	1688	21	1095.3	110	142.3	110	1423
22	2449	22		22	2950	120	1760	22	1100.0	120	146.1	120	1461
23	2460	23		23	2960	130	1833	23	1104.6	130	149.8	130	1498
24	2470	24		24	2970	140	1909	24	1109.3	140	153.6	140	1536
25	2480	25	2000	25	2980	150	1987	25	1114.0	150	157.3	150	1573
26	2491	26		26	2990	160	2066	26	1120.0	160	161.0	160	1611
27	2501	27		27	3000	170	2148	27	1123.4	170	164.8	170	1648
28	2512	28		28	3010	<b>180</b>	2232	28	1128.1	180	168.5	180	1685
29	2522	29		29	3020	29		29	1132.9	190	172.2	190	1722
30	2532	30	2080	30	3030	30		30	1137.6	200	175.8	200	1758
35	2585	35		35	3080	35		35	1161.5	210	179.5	210	1795
40	2638	40	2245	40	3130	40		40	1185.7	220	183.2	220	1832
45	2692	45		45	3180	45		45	1210.2	230	186.8	230	1868
50	2745	50	2417	50	3230	50		50	1235.0	240	190.5	240	1905
55	2800	55		55	3280	55		55	1260.1	250	194.1	250	1941
60	2855	60	2597	60	3330	60		60	1285.4	260	197.7	260	1977
65	2910	65		65	3380	65		65	1311.1	270	201.3	270	2013
70	2966	70	2785	70	3430	70		70	1337.1	280	204.9	280	2049
75	3022	75		75	3480	75		75	1363.5	290	208.5	290	2085
80	3079	80	2980	80	3530	80		80	1390.1	300	212.0	300	2121
85	3136	85		85	3580	85		85	1417.1	310	215.6	310	2156
90	3194	90	3182	90	3630	90		90	1444.4	320	219.1	320	2191
95	3252	95		95	3680	95		95	1472.0	330	222.7	330	2227
100	3311	100	3392	100	3730	100		100	1500.0	340	226.2	340	2262
105	3370	105		105	3780	105		105	1528.3	350	229.7	350	2297
110	3430	110	3607	110	3830	110		110	1557.0	360	233.2	360	2332
115	3491	115		115	3880	115		115	1586.0	370	236.7	370	2367
120	3552	120	3817	120	3930	120		<b>120</b>	1625.4	380	240.1	380	2401
125	3613	125	3915	125	3980	125				390	243.6	390	2436
130	3675	130	4008	130	-	130				<b>400</b>	247.0	<b>400</b>	2470
140	3802	140	4166	140	-	140							
150	3929	150	4280	150	-	150							



**Sensor type (+)**  
**Thermistor elements with positive temperature coefficient -**  
**Temperature ranges (temperature/resistance)**

Accuracy of passive elements			
Sensor elements	Tolerance	Standard	Rated zero-power resistance
Pt 1000	± 0.3 K / 0 °C	DIN EN 60 751, class B	TK = 3850 ppm / K
Pt 1000 1/3 DIN	± 0.1 K / 0 °C	DIN EN 60 751, class A	TK = 3850 ppm / K
Pt 1000 A	± 0.15 K / 0 °C	DIN EN 60 751, class A, TGA	TK = 3850 ppm / K
Pt 1000 1/10 DIN	± 0.03 K / 0 °C	DIN EN 60 751, class A	TK = 3850 ppm / K
Pt 100	± 0.3 K / 0 °C	DIN EN 60 751, class B	TK = 3850 ppm / K
Pt 100 1/3 DIN	± 0.1 K / 0 °C	DIN EN 60 751, class A	TK = 3850 ppm / K
Ni 1000	± 0.4 K / 0 °C	DIN EN 43 760, class B	TCR = 6180 ppm / K
Ni 1000 1/2 DIN	± 0.2 K / 0 °C	DIN EN 43 760, class B	TCR = 6180 ppm / K
Ni 1000 TK5000	± 0.4 K / 0 °C		TCR = 5000 ppm / K
LM235Z, KP10	± 0.2 K / 25 °C	10 mV / K	
NTC 1.8K	± 0.3 K / 25 °C	B25 / 85 = 3499 K	R25 = 1.8 K ± 0.3 %
NTC 2.2K	± 0.3 K / 25 °C	B25 / 85 = 3610 K	R25 = 2.2 K ± 1 %
NTC 10K	± 0.3 K / 25 °C	B25 / 85 = 3977 K	R25 = 10 KOhm ± 1 %
NTC 10K Precon	± 0.3 K / 25 °C	B25 / 85 = 3695 K	R25 = 10 KOhm ± 1 %
NTC 10K Carell	± 0.3 K / 25 °C	B25 / 85 = 3435 K	R25 = 10 KOhm ± 1 %
NTC 20K	± 0.2 K / 25 °C	B25 / 85 = 4262 K	R25 = 20 KOhm ± 0.5 %

**ATTENTION, NOTE !**

Due to self-heating, the testing current has an influence on the measuring accuracy of the thermometer and should therefore never exceed the following:

**Guide values for the testing current:**

Maximum sensor current .....	$I_{max}$
Pt1000 (thin layer) .....	< 0.6 mA
Pt100 (thin layer) .....	< 1.0 mA
Ni1000 (DIN), Ni1000 TK5000 .....	< 0.3 mA
NTC xx .....	< 2.0 mW
LM235Z .....	400 µA ... 5 mA
KTY 81 - 210 .....	< 2.0 mA

**To avoid damage/errors, it is recommended to use shielded cables. It is imperative to avoid parallel laying of current-carrying lines. The EMC directives must be observed!**

**These devices must be installed by an authorised qualified expert!**

## Sensor type (-)

Thermistor elements with negative temperature coefficient -

Temperature ranges [temperature/resistance]

NTC 1,8 kΩ		NTC 2,2 kΩ		NTC 3 kΩ		NTC 5 kΩ		NTC 10 kΩ		NTC 10 kΩ Precon		NTC 10K e.g. Carell	
R <sub>25</sub> = 1.8 kΩ ±0,2K B <sub>25/85</sub> = 3499 K ±1%		R <sub>25</sub> = 2.2 kΩ ±1% B <sub>25/85</sub> = 3610 K ±1%		R <sub>25</sub> = 3 kΩ ±1% B <sub>25/85</sub> = 3977 K ±1%		R <sub>25</sub> = 5 kΩ ±1% B <sub>25/85</sub> = 3977 K ±1%		R <sub>25</sub> = 10 kΩ ±1% B <sub>25/85</sub> = 3977 K ±1%		R <sub>25</sub> = 10 kΩ ±1% B <sub>25/85</sub> = 3695 K ±1%		R <sub>25</sub> = 10 kΩ ±1% B <sub>25/85</sub> = 3435 K ±1%	
°C	Ω	°C	Ω	°C	Ω	°C	Ω	°C	Ω	°C	Ω	°C	Ω
- 50	-	- 50	-	- 50	-	- 50	-	- 50	-	- 50	-	- 50	-
- 40	39073	- 40	-	- 40	-	- 40	-	- 40	-	- 40	-	- 40	-
- 30	22301	- 30	27886	- 30	53093	- 30	88488	- 30	175785	- 30	135200	- 30	111300
- 20	13196	- 20	16502	- 20	29125	- 20	48541	- 20	96597	- 20	78910	- 20	67770
- 15	10278	- 15	12844	- 15	21887	- 15	36479	- 15	72650	- 15	61020	- 15	53410
- 10	8069	- 10	10070	- 10	16599	- 10	27664	- 10	55142	- 10	47540	- 10	42470
- 5	6383	- 5	8134	- 5	12698	- 5	21163	- 5	42215	- 5	37310	- 5	33900
0	5085	0	6452	0	9795	0	16325	0	32590	0	29490	0	27280
1	4863	1	6164	1	9309	1	15515	1	30974	1	28156	1	26130
2	4652	2	5891	2	8849	2	14749	2	29448	2	26890	2	25030
3	4452	3	5631	3	8415	3	14025	3	28007	3	25687	3	23990
4	4261	4	5384	4	8005	4	13341	4	26645	4	24545	4	23000
5	4079	5	5150	5	7617	5	12695	5	25357	5	23460	5	22050
6	3906	6	4927	6	7251	6	12085	6	24138	6	22430	6	21150
7	3742	7	4715	7	6905	7	11508	7	22984	7	21451	7	20300
8	3585	8	4513	8	6575	8	10959	8	21892	8	20519	8	19480
9	3436	9	4321	9	6265	9	10442	9	20858	9	19633	9	18700
10	3294	10	4138	10	5971	10	9951	10	19880	10	18790	10	17960
11	3159	11	3964	11	5691	11	9485	11	18953	11	17987	11	17240
12	3030	12	3797	12	5427	12	9045	12	18074	12	17222	12	16560
13	2906	13	3639	13	5177	13	8628	13	17242	13	16494	13	15900
14	2789	14	3488	14	4938	14	8230	14	16452	14	15801	14	15280
15	2677	15	3345	15	4713	15	7855	15	15704	15	15140	15	14690
16	2570	16	3207	16	4500	16	7500	16	14992	16	14510	16	14120
17	2468	17	3076	17	4298	17	7163	17	14317	17	13910	17	13580
18	2371	18	2952	18	4104	18	6841	18	13676	18	13337	18	13060
19	2278	19	2832	19	3922	19	6536	19	13068	19	12791	19	12560
20	2189	20	2719	20	3747	20	6246	20	12491	20	12270	20	12090
21	2104	21	2610	21	3582	21	5970	21	11941	21	11773	21	11630
22	2023	22	2506	22	3426	22	5710	22	11418	22	11298	22	11200
23	1945	23	2407	23	3277	23	5462	23	10921	23	10845	23	10780
24	1871	24	2289	24	3135	24	5224	24	10450	24	10413	24	10380
25	1800	25	2200	25	3000	25	5000	25	10000	25	10000	25	10000
26	1732	26	2115	26	2872	26	4787	26	9572	26	9606	26	9632
27	1667	27	2034	27	2750	27	4583	27	9166	27	9229	27	9281
28	1605	28	1957	28	2634	28	4389	28	8778	28	8869	28	8944
29	1546	29	1883	29	2522	29	4203	29	8409	29	8525	29	8622
30	1489	30	1812	30	2417	30	4028	30	8058	30	8196	30	8313
35	1238	35	1500	35	1960	35	3266	35	6534	35	6754	35	6940
40	1034	40	1248	40	1597	40	2662	40	5329	40	5594	40	5827
45	869	45	1043	45	1310	45	2184	45	4371	45	4655	45	4911
50	733	50	876	50	1081	50	1801	50	3605	50	3893	50	4160
55	622	55	738	55	896	55	1493	55	2988	55	3270	55	3536
60	529	60	626	60	746	60	1244	60	2489	60	2760	60	3020
65	453	65	532	65	625	65	1042	65	2084	65	2338	65	2588
70	389	70	454	70	526	70	876	70	1753	70	1900	70	2228
75	335	75	390	75	444	75	740	75	1480	75	1700	75	1924
80	290	80	335	80	346	80	627	80	1256	80	1457	80	1668
85	252	85	289	85	321	85	535	85	1070	85	1254	85	1451
90	220	90	251	90	275	90	458	90	915	90	1084	90	1266
95	192	95	218	95	236	95	393	95	786	95	939	95	1108
100	169	100	190	100	204	100	339	100	678	100	817	100	973
105	148	105	167	105	176	105	294	105	586	105	713	105	857
110	131	110	146	110	138	110	255	110	509	110	624	110	758
115	116			115	120	115	223	115	445	115	548	115	671
120	103			120	105	120	195	120	389	120	482	120	597
125	92			125	92	125	171	125	341	125	426	125	531
				130	81	130	151	130	300	130	377	130	474
				140	64	140	118	140	234	140	298	140	381
				150	50	150	93	150	185	150	238	150	308



Sensor type (-)  
 Thermistor elements with negative temperature coefficient -  
 Temperature ranges (temperature/resistance)

NTC 20 kΩ		NTC 50 kΩ		Satchwell SAT 1	
R <sub>25</sub> = 20 kΩ ±0.5%		R <sub>25</sub> = 50 kΩ ±1%			
B <sub>25/85</sub> = 4262 K ±1%		B <sub>25/85</sub> = 4262 K ±1%			
°C	Ω	°C	Ω	°C	Ω
- 50	-	- 50	-	- 50	9719
- 40	806800	- 40	2017000	- 40	9584
- 30	413400	- 30	1033500	- 30	9349
- 20	220600	- 20	551500	- 20	8968
- 15	163480	- 15	408700	- 15	8708
- 10	122260	- 10	305650	- 10	8396
- 5	92220	- 5	230550	- 5	8031
0	70140	0	175350	0	7614
1	66469	1	166173	1	7525
2	63011	2	157527	2	7434
3	59751	3	149378	3	7341
4	56678	4	141696	4	7246
5	53780	5	134450	5	7150
6	51041	6	127602	6	7053
7	48457	7	121142	7	6954
8	46018	8	115044	8	6853
9	43715	9	109287	9	6752
10	41540	10	103850	10	6649
11	39489	11	98723	11	6545
12	37550	12	93875	12	6440
13	35716	13	89291	13	6334
14	33982	14	84954	14	6228
15	32340	15	80850	15	6121
16	30782	16	76954	16	6013
17	29307	17	73269	17	5905
18	27912	18	69780	18	5786
19	26591	19	66478	19	5684
20	25340	20	63350	20	5580
21	24156	21	60389	21	5471
22	23033	22	57582	22	5362
23	21968	23	54921	23	5254
24	20958	24	52396	24	5147
25	20000	25	50000	25	5039
26	19090	26	47726	26	4933
27	18227	27	45566	27	4827
28	17406	28	43515	28	4721
29	16627	29	41567	29	4617
30	15886	30	39715	30	4513
35	12698	35	31745	35	4012
40	10212	40	25530	40	3545
45	8260	45	20650	45	3117
50	6718	50	16795	50	2730
55	5494	55	13735	55	2386
60	4518	60	11295	60	2082
65	3732	65	9330	65	1816
70	3098	70	7745	70	1585
75	2586	75	6465	75	1385
80	2166	80	5415	80	1213
85	1823	85	4558	85	1064
90	1541	90	3852	90	937
95	1308	95	3269	95	828
100	1114	100	2785	100	734
105	953	105	2382	105	654
110	818	110	2045	110	585
115	704	115	1761	115	525
120	609	120	1523	120	474
125	528	125	1321	125	429
130	460	130	1149	130	391
140	351	140	878	140	329
150	272	150	679	150	281

Sensor type (-)

Resistor element with **negative** temperature coefficient, also called negative temperature coefficient thermistor, or NTC thermistor.

To avoid damage/errors, it is recommended to use shielded cables. It is imperative to avoid parallel laying of current-carrying lines. The EMC directives must be observed!

These devices must be installed by an authorised qualified expert!

**Characteristics and wiring of terminal connections of some passive temperature sensors**

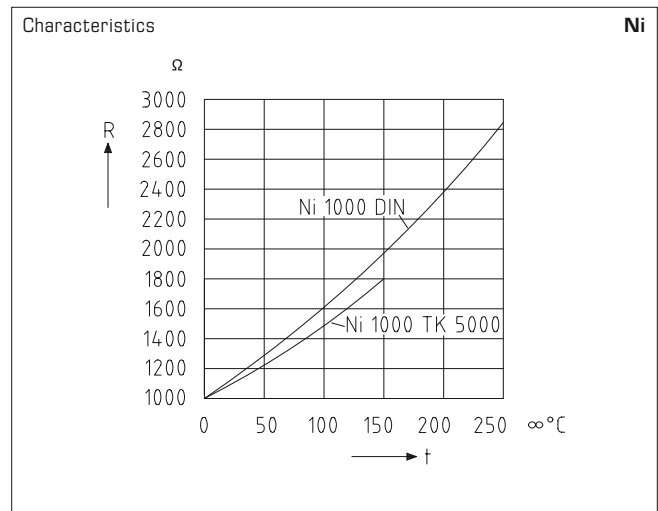
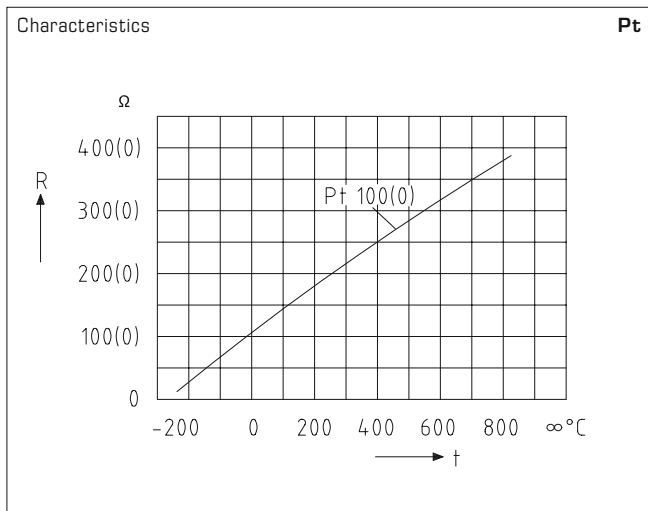

**Wiring of terminal connections room devices and box head**

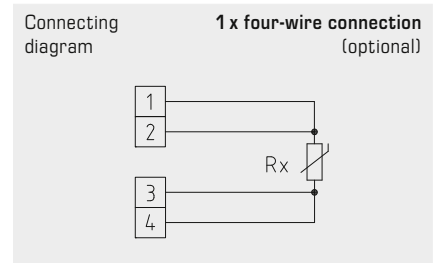
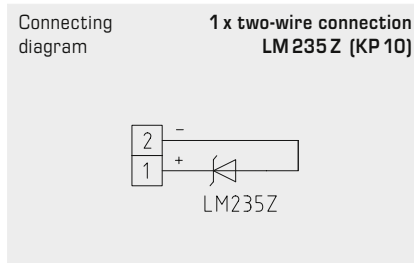
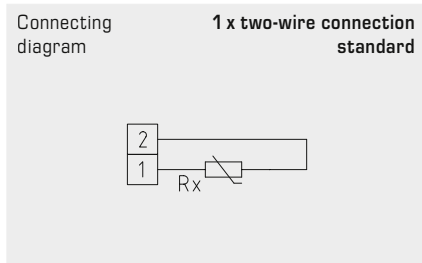

**Wiring of terminal connections head form B**

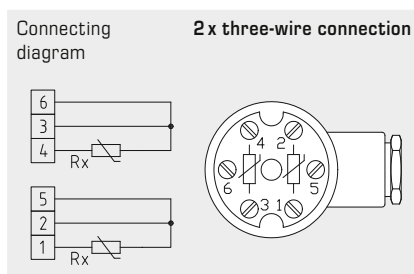
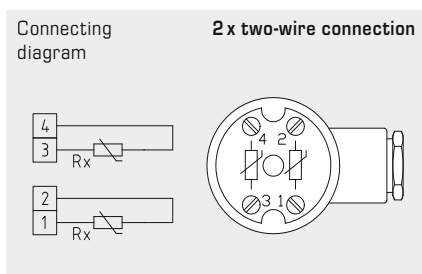
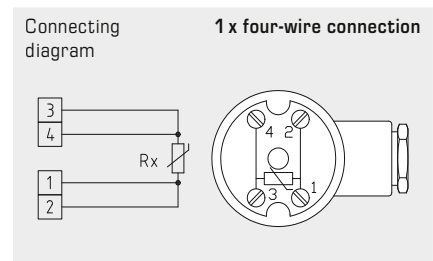
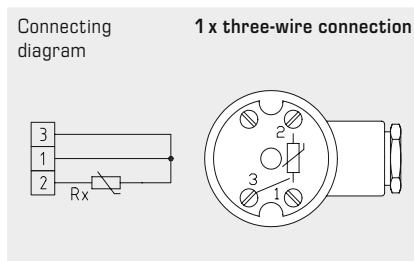
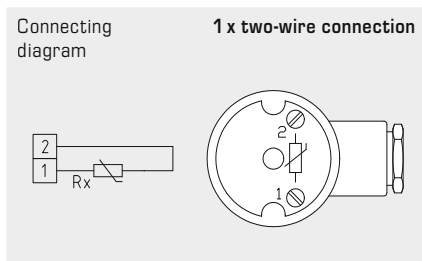



Measuring transducers, calibratable, with active output for THERMASGARD® temperature sensors

TEMPERATURE RANGES:

When selecting measuring transducer ranges, it is necessary to ensure that the maximum temperatures permissible for the sensor/enclosure are not exceeded!

Ambient temperature for measuring transducers: -30...+70°C

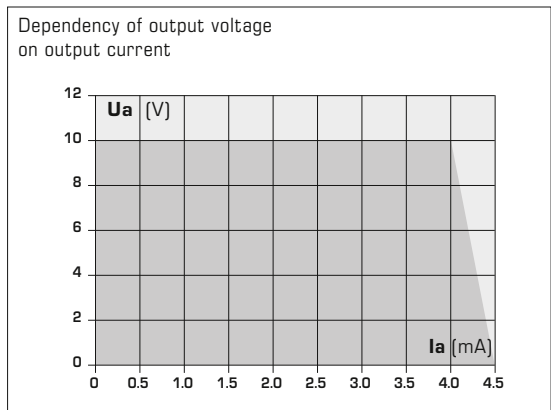
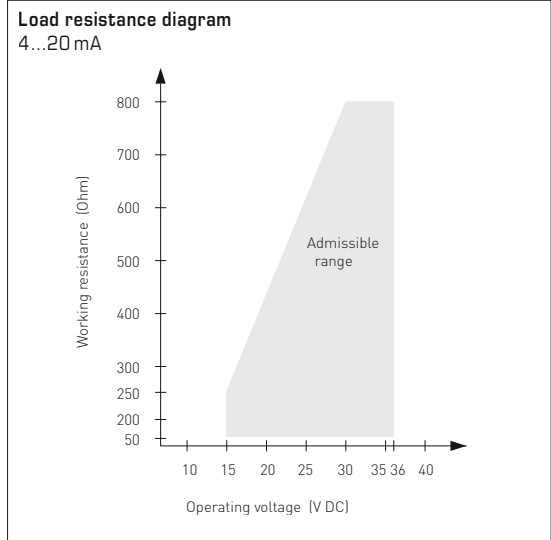

SUPPLY VOLTAGE:

For operating voltage reverse polarity protection, a one-way rectifier or reverse polarity protection diode is integrated in this device variant. This internal one-way rectifier also allows operating 0 - 10V devices on AC supply voltage.

The output signal is to be tapped by a measuring instrument. Output voltage is measured here against zero potential (0V) of the input voltage!

When this device is operated on DC supply voltage, the operating voltage input UB+ is to be used for 15...36V DC supply and UB- or GND for ground wire!

When several devices are supplied by one 24V AC voltage supply, it is to be ensured that all "positive" operating voltage input terminals (+) of the field devices are connected with each other and all "negative" operating voltage input terminals (-) = reference potential are connected together (in-phase connection of field devices).

All outputs of field devices must be referenced to the same potential!

In the event of a reversed polarity at one field device, that device would cause a supply voltage short-circuit. The resulting short-circuit current flowing through this field device may cause damage to it.

Therefore, ensure correct wiring!

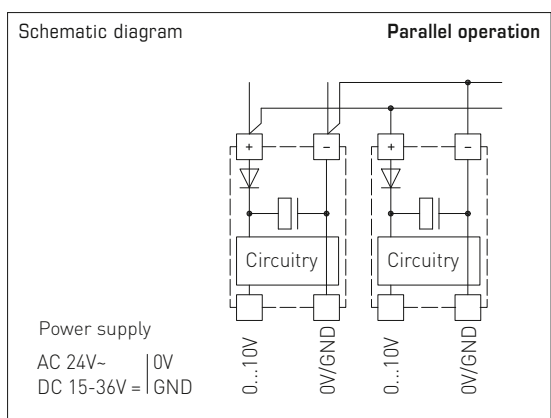
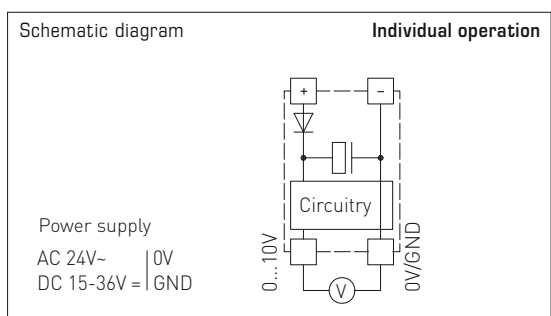

Range of preferential items permanently available from stock in standard design with S+S company logo

## THERMASGARD® TF 43

Temperature sensors (basic device)

Type/WG03B	Output	Item No.	Price
<b>TF 43 PT1000 xx</b>	passive	<b>IP54</b>	
TF43 Pt1000 50mm		1101-7010-5011-000	26,92 €
TF43 Pt1000 100mm		1101-7010-5021-000	27,04 €
TF43 Pt1000 150mm		1101-7010-5031-000	27,90 €
TF43 Pt1000 200mm		1101-7010-5041-000	28,68 €
TF43 Pt1000 250mm		1101-7010-5051-000	30,14 €
TF43 Pt1000 300mm		1101-7010-5061-000	32,62 €
TF43 Pt1000 350mm		1101-7010-5071-000	33,62 €
TF43 Pt1000 400mm		1101-7010-5081-000	34,69 €
<b>TF 43 Ni1000 xx</b>	passive	<b>IP54</b>	
TF43 Ni1000 50mm		1101-7010-9011-000	27,59 €
TF43 Ni1000 100mm		1101-7010-9021-000	30,20 €
TF43 Ni1000 150mm		1101-7010-9031-000	30,42 €
TF43 Ni1000 200mm		1101-7010-9041-000	31,09 €
TF43 Ni1000 250mm		1101-7010-9051-000	31,96 €
TF43 Ni1000 300mm		1101-7010-9061-000	34,07 €
TF43 Ni1000 350mm		1101-7010-9071-000	35,04 €
TF43 Ni1000 400mm		1101-7010-9081-000	36,61 €
<b>TF 43 Ni1000TK xx</b>	passive	<b>IP54</b>	
TF43 NiTK 50mm		1101-7011-0011-000	27,64 €
TF43 NiTK 100mm		1101-7011-0021-000	30,26 €
TF43 NiTK 150mm		1101-7011-0031-000	30,57 €
TF43 NiTK 200mm		1101-7011-0041-000	31,22 €
TF43 NiTK 250mm		1101-7011-0051-000	32,07 €
TF43 NiTK 300mm		1101-7011-0061-000	34,20 €
TF43 NiTK 350mm		1101-7011-0071-000	35,27 €
TF43 NiTK 400mm		1101-7011-0081-000	36,74 €
<b>TF 43 LM235Z xx</b>	passive	<b>IP54</b>	
TF43 LM235Z 50mm		1101-7012-1011-000	28,13 €
TF43 LM235Z 100mm		1101-7012-1021-000	28,44 €
TF43 LM235Z 150mm		1101-7012-1031-000	29,47 €
TF43 LM235Z 200mm		1101-7012-1041-000	30,14 €
TF43 LM235Z 250mm		1101-7012-1051-000	30,49 €
TF43 LM235Z 300mm		1101-7012-1061-000	33,10 €
TF43 LM235Z 350mm		1101-7012-1071-000	33,50 €
TF43 LM235Z 400mm		1101-7012-1081-000	35,60 €
<b>TF 43 NTC 1,8K xx</b>	passive	<b>IP54</b>	
TF43 NTC1,8K 50mm		1101-7011-2011-000	26,92 €
TF43 NTC1,8K 100mm		1101-7011-2021-000	28,38 €
TF43 NTC1,8K 150mm		1101-7011-2031-000	29,10 €
TF43 NTC1,8K 200mm		1101-7011-2041-000	29,78 €
TF43 NTC1,8K 250mm		1101-7011-2051-000	31,22 €
TF43 NTC1,8K 300mm		1101-7011-2061-000	32,25 €
TF43 NTC1,8K 350mm		1101-7011-2071-000	33,34 €
TF43 NTC1,8K 400mm		1101-7011-2081-000	34,20 €
<b>TF 43 NTC10K xx</b>	passive	<b>IP54</b>	
TF43 NTC10K 50mm		1101-7011-5011-000	26,92 €
TF43 NTC10K 100mm		1101-7011-5021-000	28,38 €
TF43 NTC10K 150mm		1101-7011-5031-000	29,10 €
TF43 NTC10K 200mm		1101-7011-5041-000	29,78 €
TF43 NTC10K 250mm		1101-7011-5051-000	31,22 €
TF43 NTC10K 300mm		1101-7011-5061-000	32,25 €
TF43 NTC10K 350mm		1101-7011-5071-000	33,34 €
TF43 NTC10K 400mm		1101-7011-5081-000	34,20 €
<b>TF 43 NTC20K xx</b>	passive	<b>IP54</b>	
TF43 NTC20K 50mm		1101-7011-6011-000	26,92 €
TF43 NTC20K 100mm		1101-7011-6021-000	28,38 €
TF43 NTC20K 150mm		1101-7011-6031-000	29,10 €
TF43 NTC20K 200mm		1101-7011-6041-000	29,78 €
TF43 NTC20K 250mm		1101-7011-6051-000	31,22 €
TF43 NTC20K 300mm		1101-7011-6061-000	32,25 €
TF43 NTC20K 350mm		1101-7011-6071-000	33,34 €
TF43 NTC20K 400mm		1101-7011-6081-000	34,20 €



Range of preferential items permanently available from stock in standard design with S+S company logo

## THERMASGARD® TM 43

Temperature measuring transducer (basic device), calibratable, with multi-range switching



Basic device  
(without accessories)



Immersion / screw-in  
temperature sensor  
with immersion sleeve  
(accessories)



Duct temperature sensor  
with mounting flange  
(accessories)

Type / WG01B	Output	Item No.	Price
<b>TM43-U xx</b>	<b>active</b>	<b>IP54</b>	
TM43-U 50mm	0 -10 V	1101-7111-0019-900	<b>68,85 €</b>
TM43-U 100mm	0 -10 V	1101-7111-0029-900	<b>69,98 €</b>
TM43-U 150mm	0 -10 V	1101-7111-0039-900	<b>71,00 €</b>
TM43-U 200mm	0 -10 V	1101-7111-0049-900	<b>71,34 €</b>
TM43-U 250mm	0 -10 V	1101-7111-0059-900	<b>72,53 €</b>
TM43-U 300mm	0 -10 V	1101-7111-0069-900	<b>73,71 €</b>
<b>TM43-I xx</b>	<b>active</b>	<b>IP54</b>	
TM43-I 50mm	4...20 mA	1101-7112-0019-900	<b>68,85 €</b>
TM43-I 100mm	4...20 mA	1101-7112-0029-900	<b>69,98 €</b>
TM43-I 150mm	4...20 mA	1101-7112-0039-900	<b>71,00 €</b>
TM43-I 200mm	4...20 mA	1101-7112-0049-900	<b>71,34 €</b>
TM43-I 250mm	4...20 mA	1101-7112-0059-900	<b>72,53 €</b>
TM43-I 300mm	4...20 mA	1101-7112-0069-900	<b>73,71 €</b>

### Accessories for basic device TF43 / TM43



Type / WG01B	Item No.	Price
<b>Immersion sleeves</b>		
<b>TH08- ms / xx</b> (T <sub>max</sub> +150 °C)	Brass nickel-plated	
TH08-MS 50MM	7100-0011-0010-132	<b>8,87 €</b>
TH08-MS 100MM	7100-0011-0020-132	<b>10,10 €</b>
TH08-MS 150MM	7100-0011-0030-132	<b>10,67 €</b>
TH08-MS 200MM	7100-0011-0040-132	<b>11,01 €</b>
TH08-MS 250MM	7100-0011-0050-132	<b>12,75 €</b>
TH08-MS 300MM	7100-0011-0060-132	<b>13,10 €</b>
TH08-MS 350MM	7100-0011-0070-132	<b>13,21 €</b>
TH08-MS 400MM	7100-0011-0080-132	<b>13,33 €</b>
<b>TH08- VA / xx</b> (T <sub>max</sub> +600 °C)	Stainless steel V4A (1.4571)	
TH08-VA 50MM	7100-0012-0010-132	<b>19,31 €</b>
TH08-VA 100MM	7100-0012-0020-132	<b>21,34 €</b>
TH08-VA 150MM	7100-0012-0030-132	<b>22,93 €</b>
TH08-VA 200MM	7100-0012-0040-132	<b>24,17 €</b>
TH08-VA 250MM	7100-0012-0050-132	<b>30,05 €</b>
TH08-VA 300MM	7100-0012-0060-132	<b>31,40 €</b>
TH08-VA 350MM	7100-0012-0070-132	<b>31,61 €</b>
TH08-VA 400MM	7100-0012-0080-132	<b>32,17 €</b>
<b>Mounting flanges</b>		
<b>MF-15-K</b> Ø 15.2 mm (T <sub>max</sub> +100 °C)	Plastic	
	7100-0032-0000-000	<b>5,83 €</b>

Range of preferential items permanently available from stock in standard design with S+S company logo

## THERMASGARD® ATF 01

Outside temperature sensors / wet room temperature sensors

Type/WG03B	Output	Item No.	Price
<b>ATF 01 xx</b>	<b>passive</b>	<b>IP 54</b>	
ATF01 Pt1000		1101-1030-5001-000	17,05 €
ATF01 Ni1000		1101-1030-9001-000	17,81 €
ATF01 NiTK		1101-1031-0001-000	20,67 €
ATF01 LM235Z		1101-1032-1001-000	15,01 €
ATF01 NTC1,8K		1101-1031-2001-000	13,83 €
ATF01 NTC10K		1101-1031-5001-000	13,83 €
ATF01 NTC20K		1101-1031-6001-000	13,83 €



## THERMASGARD® ATM2-SD

Outside temperature / wet room temperature measuring transducers calibratable, with multi-range switching

Type/WG01B	Output	Item No.	Price
<b>ATM 2-SD</b>	<b>active</b>	<b>IP 54</b>	
ATM2-SD-U	0 -10 V	1101-1191-0009-900	81,52 €
ATM2-SD-I	4...20 mA	1101-1192-0009-900	81,52 €



## THERMASGARD® ALTF 02

Surface contact temperature sensors / tube contact temperature sensors, compact variant

Type/WG03B	Output	Item No.	Price
<b>ALTF02 xx</b>	<b>passive</b>	<b>IP 54</b>	
ALTF02 Pt1000		1101-1010-5001-000	20,62 €
ALTF02 Ni1000		1101-1010-9001-000	20,97 €
ALTF02 NiTK		1101-1011-0001-000	24,01 €
ALTF02 LM235Z		1101-1012-1001-000	21,22 €
ALTF02 NTC1,8K		1101-1011-2001-000	20,00 €
ALTF02 NTC10K		1101-1011-5001-000	20,00 €
ALTF02 NTC20K		1101-1011-6001-000	20,00 €



## THERMASGARD® ALTM1-SD

Surface contact / tube contact temperature measuring transducers, compact variant, calibratable, with multi-range switching

Type/WG01B	Output	Item No.	Price
<b>ALTM1-SD</b>	<b>active</b>	<b>IP 54</b>	
ALTM1-SD-U	0 -10 V	1101-6141-0219-920	80,18 €
ALTM1-SD-I	4...20 mA	1101-6142-0219-920	80,18 €



Range of preferential items permanently available from stock  
in standard design with S+S company logo

## THERMASGARD® ALTF 1

Surface contact temperature sensors / tube contact temperature sensors,  
**with detached sensor head,**  
(L = 50 mm, cable material: PVC, cable length: 1.5 m, without housing)

Type / WG03B	Output	Item No.	Price
<b>ALTF 1 xx</b>	<b>passive</b>	<b>IP65</b>	
ALTF1 Pt1000 PVC 1,5M		1101-6020-5211-110	<b>19,29 €</b>
ALTF1 Ni1000 PVC 1,5M		1101-6020-9211-110	<b>20,00 €</b>
ALTF1 NiTK PVC 1,5M		1101-6021-0211-110	<b>20,74 €</b>
ALTF1 LM235Z PVC 1,5M		1101-6022-1211-110	<b>20,37 €</b>
ALTF1 NTC1,8K PVC 1,5M		1101-6021-2211-110	<b>19,77 €</b>
ALTF1 NTC10K PVC 1,5M		1101-6021-5211-110	<b>19,77 €</b>
ALTF1 NTC20K PVC 1,5M		1101-6021-6211-110	<b>19,77 €</b>



## THERMASGARD® ALTM2-SD

Surface contact / tube contact temperature measuring transducers,  
**with detached sensor head,**  
calibratable, with multi-range switching  
(L = 50 mm, cable material: silicone, cable length: 1.5 m, with housing)

Type / WG01B	Output	Item No.	Price
<b>ALTM2-SD</b>	<b>active</b>	<b>IP54</b>	
ALTM2-SD-U	0 -10 V	1101-6151-0219-920	<b>79,38 €</b>
ALTM2-SD-I	4...20 mA	1101-6152-0219-920	<b>79,38 €</b>



## THERMASGARD® HTF 50

Sleeve temperature sensors / cable temperature sensors  
(L = 50 mm, cable material: PVC, cable length: 1.5 m, without housing)

Type / WG03B	Output	Item No.	Price
<b>HTF 50 xx</b>	<b>passive</b>	<b>IP65</b>	
HTF50 Pt1000 PVC 1,5M		1101-6030-5211-110	<b>15,35 €</b>
HTF50 Ni1000 PVC 1,5M		1101-6030-9211-110	<b>14,91 €</b>
HTF50 NiTK PVC 1,5M		1101-6031-0211-110	<b>18,80 €</b>
HTF50 LM235Z PVC 1,5M		1101-6032-1211-110	<b>13,35 €</b>
HTF50 NTC1,8K PVC 1,5M		1101-6031-2211-110	<b>12,61 €</b>
HTF50 NTC10K PVC 1,5M		1101-6031-5211-110	<b>12,61 €</b>
HTF50 NTC20K PVC 1,5M		1101-6031-6211-110	<b>12,61 €</b>

## THERMASGARD® HFTM-SD

Sleeve sensors with temperature measuring transducer,  
calibratable, with multi-range switching  
(L = 50 mm, cable material: PVC, cable length: 1.5 m, with housing)

Type / WG01B	Output	Item No.	Price
<b>HFTM-SD</b>	<b>active</b>	<b>IP54</b>	
HFTM-SD-U	0 -10 V	1101-6161-0219-920	<b>77,01 €</b>
HFTM-SD-I	4...20 mA	1101-6162-0219-920	<b>77,01 €</b>

Range of preferential items permanently available from stock in standard design with S+S company logo

## THERMASGARD® RTF1-SD

Room temperature sensors without operating elements

Type/WG03B	Output	Item No.	Price
<b>RTF1-SD xx</b>	<b>passive</b>	<b>IP30</b>	
RTF1-SD Pt1000		1101-40D0-5000-000	<b>18,52 €</b>
RTF1-SD Ni1000		1101-40D0-9000-000	<b>18,18 €</b>
RTF1-SD NiTK		1101-40D1-0000-000	<b>21,06 €</b>
RTF1-SD LM235Z		1101-40D2-1000-000	<b>17,05 €</b>
RTF1-SD NTC1,8K		1101-40D1-2000-000	<b>15,52 €</b>
RTF1-SD NTC10K		1101-40D1-5000-000	<b>15,52 €</b>
RTF1-SD NTC10K (B=3695K)		1101-40D1-9000-000	<b>15,52 €</b>
RTF1-SD NTC20K		1101-40D1-6000-000	<b>15,52 €</b>



## THERMASGARD® RTM1-SD

Room temperature measuring transducers without operating elements

Type/WG01B	Output	Item No.	Price
<b>RTM1-SD</b>	<b>active</b>	<b>IP30</b>	
RTM1-SD-U	0 -10 V	1101-41D1-0000-200	<b>69,62 €</b>
RTM1-SD-I	4...20 mA	1101-41D2-0000-200	<b>69,62 €</b>

## THERMASGARD® MWTF-SD

Mean value / rod / duct temperature sensor including mounting flange (Measuring rod: reinforced thermoplastic tube, NL = 3m / 6m)

Type/WG03B	Output	Item No.	Price
<b>MWTF-SD xx</b>	<b>passive</b>	<b>IP54</b>	
MWTF-SD Pt1000 3m		1101-3050-5231-200	<b>90,12 €</b>
MWTF-SD Pt1000 6m		1101-3050-5261-200	<b>100,27 €</b>



## THERMASGARD® MWTM-SD

Mean value / rod / duct temperature measuring transducer, including mounting flange, calibratable, with multi-range switching (Measuring rod: reinforced thermoplastic tube, NL = 3m / 6m)

Type/WG01B	Output	Item No.	Price
<b>MWTM-SD-U</b>	<b>active</b>	<b>IP54</b>	
MWTM-SD-U 3m	0 -10 V	1101-3131-0239-90K	<b>149,61 €</b>
MWTM-SD-U 6m	0 -10 V	1101-3131-0269-90K	<b>158,64 €</b>
<b>MWTM-SD-I</b>	<b>active</b>	<b>IP54</b>	
MWTM-SD-I 3m	4...20 mA	1101-3132-0239-90K	<b>152,82 €</b>
MWTM-SD-I 6m	4...20 mA	1101-3132-0269-90K	<b>162,28 €</b>



## THERMASREG® FST

Frost protection thermostats, mechanical, one-step, with switching output (length of capillary 3m / 6m, incl. mounting clamps)

Type/WG03B	Output	Item No.	Price
<b>FST-xxD</b>	<b>switching</b>	<b>IP65</b>	
FST-1D 6m		1102-1021-0102-000	<b>83,00 €</b>
FST-5D 3m		1102-1022-0102-000	<b>80,74 €</b>



**BASIC**

S+S REGELTECHNIK

S+S Basic Programme

Range of preferential items permanently available from stock in standard design with S+S company logo

**HYGRASGARD® RFTF - SD**Room humidity and temperature sensors ( $\pm 2\%$ ), calibratable

Type / WG01B	Output	Item No.	Price
<b>RFTF-SD</b>	<b>active (2x)</b>	<b>IP30</b>	
RFTF-SD-U	0 -10 V	1201-41D1-1000-000	<b>109,27 €</b>
RFTF-SD-I	4...20 mA	1201-41D2-1000-000	<b>109,27 €</b>

**HYGRASGARD® KFF - SD**  
**HYGRASGARD® KFTF - SD**Duct humidity and temperature sensors ( $\pm 2\%$ ), including mounting flange, calibratable, with multi-range switching

Type / WG01B	Output	Item No.	Price
<b>KFF-SD</b>	<b>active</b>	<b>IP54</b>	
KFF-SD-U	0 -10 V	1201-3181-0000-029	<b>154,58 €</b>
KFF-SD-I	4...20 mA	1201-3182-0000-029	<b>154,58 €</b>
<b>KFTF-SD</b>	<b>active (2x)</b>	<b>IP54</b>	
KFTF-SD-U	0 -10 V	1201-3181-1000-029	<b>158,82 €</b>
KFTF-SD-I	4...20 mA	1201-3182-1000-029	<b>158,82 €</b>

**HYGRASGARD® AFF - SD**  
**HYGRASGARD® AFTF - SD**On-wall humidity and temperature sensors ( $\pm 2\%$ ), calibratable, with multi-range switching

Type / WG01B	Output	Item No.	Price
<b>AFF-SD</b>	<b>active</b>	<b>IP54</b>	
AFF-SD-U	0 -10 V	1201-1121-0000-100	<b>172,16 €</b>
AFF-SD-I	4...20 mA	1201-1122-0000-100	<b>172,16 €</b>
<b>AFTF-SD</b>	<b>active (2x)</b>	<b>IP54</b>	
AFTF-SD-U	0 -10 V	1201-1121-1000-100	<b>175,80 €</b>
AFTF-SD-I	4...20 mA	1201-1122-1000-100	<b>175,80 €</b>

**HYGRASREG® KW - SD**

Condensation control switches including strap

Type / WG01B	Output	Item No.	Price
<b>KW-SD</b>	<b>switching</b>	<b>IP54</b>	
KW-W-SD	Changeover contact	1202-1075-0001-020	<b>100,58 €</b>

Range of preferential items permanently available from stock in standard design with S+S company logo

## PREMASGARD® 212x-SD

Pressure, differential pressure and volume flow measuring transducers, with / without display, including connection set, adjustable, calibratable, with multi-range switching

Type / WG01B	Output	Item No.	Price
<b>max. - 1000...+ 1000 Pa</b>	<b>active</b>	<b>IP 54</b>	
PREMASGARD <b>2121-SD</b>	0-10 V / 4...20 mA	1301-11B7-0010-000	<b>129,99 €</b>
PREMASGARD <b>2121-SD LCD</b> (Display)	0-10 V / 4...20 mA	1301-11B7-2010-000	<b>176,26 €</b>
<b>max. - 5000...+ 5000 Pa</b>	<b>active</b>	<b>IP 54</b>	
PREMASGARD <b>2125-SD</b>	0-10 V / 4...20 mA	1301-11B7-0050-000	<b>129,99 €</b>
PREMASGARD <b>2125-SD LCD</b> (Display)	0-10 V / 4...20 mA	1301-11B7-2050-000	<b>176,26 €</b>
<b>max. - 100...+ 100 Pa</b>	<b>active</b>	<b>IP 54</b>	
PREMASGARD <b>2120-SD</b>	0-10 V / 4...20 mA	1301-11B7-0110-000	<b>129,99 €</b>
PREMASGARD <b>2120-SD LCD</b> (Display)	0-10 V / 4...20 mA	1301-11B7-2110-000	<b>176,26 €</b>



## PREMASREG® DS 2

Mechanical differential pressure switches for air, with / without connection set

Type / WG03B	Pressure range	Item No.	Price
<b>DS2 incl. connection set</b>		<b>IP 54</b>	
DS-205 F	20 ... 300 Pa	1302-4026-0000-000	<b>33,44 €</b>
DS-205 B	50 ... 500 Pa	1302-4022-0000-000	<b>33,44 €</b>
DS-205 D	100 ... 1000 Pa	1302-4027-0000-000	<b>33,44 €</b>
DS-205 E	500 ... 2000 Pa	1302-4028-0000-000	<b>33,44 €</b>
<b>DS2 without connection set</b>		<b>IP 54</b>	Multipack
DS-205 F	20 ... 300 Pa	1302-4026-1000- <b>M40</b>	<b>22,68 €</b>
DS-205 B	50 ... 500 Pa	1302-4022-1000- <b>M40</b>	<b>22,68 €</b>
DS-205 D	100 ... 1000 Pa	1302-4027-1000- <b>M40</b>	<b>22,68 €</b>
DS-205 E	500 ... 2000 Pa	1302-4028-1000- <b>M40</b>	<b>22,68 €</b>

**M40** = Special price per piece in the multi-pack (40 pieces)



## AERASGARD® KCO2-SD

Duct CO2 sensors, including mounting flange

Type / WG02B	Output	Item No.	Price
<b>KCO2-SD</b>	<b>active</b>	<b>IP 54</b>	
KCO2-SD-U	0-10V	1501-3160-1001-200	<b>227,91 €</b>



## AERASGARD® RCO2-SD

Room CO2 sensors, self-calibrating

Type / WG02B	Output	Item No.	Price
<b>RCO2-SD</b>	<b>active</b>	<b>IP 30</b>	
RCO2-SD-U	0-10V	1501-61A0-1001-200	<b>199,72 €</b>



**NOTE**

All devices supplied display the company logo of S + S Regeltechnik GmbH as standard!  
Neutral versions without the logo printed are available on request!

**ORDER PLACEMENT**

Orders can be placed in writing, by phone, by fax, or by e-mail. In doing so, the requested items shall be identified by denomination and quantities ordered and also the requested delivery date shall be stated. Special orders must generally be placed in writing, precisely specifying all requested special features. Or order directly ONLINE at [www.SplusS.de](http://www.SplusS.de)!

**DELIVERY PERIODS**

The catalogue items are available from stock in partial quantities – subject to prior sale.  
Delivery dates for large and special orders are determined after receipt of order / release order and mutual agreement.  
We reserve the right to make partial deliveries. Events of force majeure such as difficulties in procurement of materials, strikes, etc. entitle us to withdraw from the contract.

**TRADEMARK PROTECTION RIGHTS**

S + S Regeltechnik GmbH, S + S logo and S + S brand names are trademarks registered in the register at the German Patent and Trademark Office and must not be used in other publications without the trademark owner's prior written consent.  
All other product and company names mentioned here are brands or trademarks of the respective proprietors.

**INFRINGEMENT OF INDUSTRIAL PROPERTY RIGHTS**

Registered trademarks, trade names and general descriptive names are used in this product catalogue.  
Even if these are not expressly marked as such, the pertinent protection provisions and copyrights shall nevertheless apply.

**ATTENTION!**

**We generally only supply commercial, retail and industrial customers. We do not sell to the general public!**

**Our General Terms and Conditions of Sale and Delivery are applicable in all cases!**

**This price list supersedes all previous price lists.**

**LEGAL NOTICE**

© Copyright by S + S Regeltechnik GmbH | Version: 11/2021 GB print

Reprints, even excerpts, are only permitted with the approval of S + S Regeltechnik GmbH.  
All information provided without prejudice, technical modifications and price changes reserved.

Editor: S + S Regeltechnik GmbH, Mr. Tino Schulze and Mr. Heiko Linke, managing directors  
Graphic design: straub design

**PHOTO CREDITS**

PREFACE:  
iStock-1176511794 © iStock.com/„AvigatorPhotographer“

NEWS:  
One Cable © Beckhoff Automation GmbH & Co. KG (EtherCAT P)  
Demowall © powerIO GmbH (powerIO)  
iStock-184617128 © iStock.com/„FredFroese“

APPENDIX:  
iStock-480586617 © iStock.com/„xavierarnau“

BEGINNING OF CHAPTERS:  
iStock-482550126 © iStock.com/„vm“ (Modbus)  
iStock-510487654 © iStock.com/„shironosov“ (Humidity)  
iStock-510676770 © iStock.com/„mediaphotos“ (Light intensity)  
iStock-637081054 © iStock.com/„alvarez“ (Air quality)  
iStock-468377000 © iStock.com/„Tomml“ (Radio sensors)  
shutterstock\_121578847 © „SnnvSnnvSnnv“/Shutterstock.com (Temperature sensors passive)  
shutterstock\_412795528 © „Dmitry Kalinovsky“/Shutterstock.com (Temperature sensors active)  
shutterstock\_373407667 © „Jan Faulner“/Shutterstock.com (Temperature controllers)  
shutterstock\_423350014 © „goodluz“/Shutterstock.com (Accessories)  
Fotolia\_131639768 © "Portrait of a worker, constructing and checking development of a small business hall.  
Reliable civil engineer working on a construction site, foreman at work" @ „urbans78“ – Fotolia.com (Pressure)

## S+S Regeltechnik GmbH General Terms and Conditions of Sale and Delivery

valid as of May 2021



S+S REGELTECHNIK

### 1. Scope

- (1) Any and all quotations, services and agreements are solely made or performed on the basis of these General Terms and Conditions of Sale and Delivery of S+S Regeltechnik GmbH (S+S) in their respective valid version. These General Terms and Conditions of Sale and Delivery apply solely to companies as defined by the BGB (German Civil Code).
- (2) Customers' terms and conditions conflicting with or deviating from these General Terms and Conditions of Sale and Delivery will be acknowledged by S+S only if S+S has expressly consented to the validity of such terms in writing. The General Terms and Conditions of Sale and Delivery of S+S shall also apply if services have been provided to the customer without reservation in the knowledge of conflicting or deviating terms of that customer.
- (3) These General Terms and Conditions of Sale and Delivery of S+S shall be acknowledged by the customer's order placement or acceptance of services provided for the duration of the entire business relationship, even if these terms are not explicitly restated.

### 2. Quotation / contract conclusion / termination of contract

- (1) The quotations made by S+S are non-binding. A contract is concluded by the written order confirmation or the delivery of goods ordered insofar as S+S does not indicate via other circumstances that the order has been accepted. Insofar as the customer communicates change requests following receipt of the order confirmation, S+S is entitled to charge the additional costs resulting from this if it accepts such changes.
- (2) Illustrations, drawings and other specifications are only binding if agreed upon in writing. The same applies to advisory or informative discussions between S+S and the customer, in particular regarding the possible uses of goods ordered.

### 3. Services / dates

- (1) Delivery deadlines are only binding (fixed date transaction), if S+S has expressly confirmed this in writing.
- (2) The adherence to binding delivery deadlines presupposes the clarification of all technical and other issues as well as the timely and proper performance of any obligations by the customer.
- (3) S+S shall not be held responsible for delays in delivery for reasons beyond the control of S+S, specifically unforeseeable events that prevent or impede timely delivery. In such cases, the delivery deadline shall be extended accordingly. In the event of a delay of performance, the customer is entitled to withdraw from the non-performed part of the contract insofar as such impediment to performance continues for more than 6 weeks and a reasonable grace period for delivery has been granted. The customer's claims for damages due to the extension of the delivery deadline or if S+S is exempted from its duty to perform are excluded, insofar as the customer was notified without delay of such impediment to performance.
- (4) Insofar as S+S is responsible for the non-compliance with binding delivery dates, the liability of S+S shall be limited to 0.5% of the order value for each full week of delay, but up to a maximum of 5% of the order value of the delivery affected. The customer can only assert further claims for damages insofar as the customer has granted S+S a reasonable grace period in writing and such delay in delivery is attributable to gross negligence or intent on part of S+S.
- (5) S+S is exempt from its delivery obligation if circumstances come to light during the contractual relationship that give just cause to doubt the solvency of the customer. In this case, S+S will perform the delivery insofar as the customer makes an advance payment in respect of the purchase price, or provides appropriate sureties.
- (6) Insofar as the customer orders goods on call (in particular, pre-order), the full acceptance of the purchase or the full release order respectively shall be completed within 12 months of the date of contract conclusion or order respectively. Otherwise, the customer is obligated to accept the goods within 10 working days insofar as S+S requests this in writing.
- (7) The failure to comply with the time limit mentioned in number (6) will trigger the legal consequences of default of acceptance as defined in the BGB.
- (8) There is no general right to return goods no longer required by the purchaser or for the purpose of stock reduction.

### 4. Delivery

- (1) Shipment of goods is effected ex principal office of S+S at the customer's risk and expense (Incoterms 2010: EXW). S+S shall only take out transport, breakage, theft, or other insurance at the written request of the customer. The resulting costs shall be charged to the customer's account.
- (2) Insofar as delivery of the goods is to be carried out at a later date than the possible date of shipment at the customer's request, S+S is entitled to charge the costs of storage to the customer's account, starting one month after the notification of readiness for delivery at a flat rate at 0.5% of the order value for each month, subject to the provision of other evidence. One month after notification of readiness for delivery, S+S is alternatively entitled to request the customer to accept the goods and, in case of non-acceptance, to dispose of the goods in another manner. The customer is then to be supplied within a reasonably extended deadline.

- (3) Partial performances are permissible insofar as this is not unreasonable to the customer.

### 5. Prices / payment terms

- (1) The prices of S+S are subject to the statutory value added tax at the respective rate in effect, ex principal office of S+S and plus transport/shipping and packaging costs to be separately charged. For orders of less than EUR 75.00 in value, we reserve the right to charge a low-quantity surcharge in the amount of EUR 15.00. For custom-made items, we charge setup expenditure at cost. Existing customers whose previous payment was received more than 12 months ago as well as new customers from Germany are supplied two times subject to prepayment and then, after a positive creditworthiness check by our Euler Hermes trade credit default insurance, by payment on account. Deliveries to customers outside Germany are subject to prepayment.
- (2) S+S is entitled to issue partial invoices in accordance with the progress of the order.
- (3) The invoice amount is due for payment on receipt of the invoice. Insofar as payment is not effected within 14 working days of the date of performance of goods and receipt of the invoice, the customer shall be deemed to be in default. All payments must be made in EUR. Notwithstanding evidence of further damages, the customer in the case of payment default shall pay interest on arrears at a rate of 8 percentage points above the respective base rate.
- (4) Bills of exchange and checks are only accepted as conditional payment and take fulfilling effect only after being unconditionally credited. Possible ancillary costs arising due to payment by bills of exchange or check shall be charged to the customer.

### 6. Warranty entitlements of the purchaser

- (1) The rights of the purchaser regarding material defects and defects of title (including incorrect and under-delivery as well as improper assembly or incorrect assembly instructions) shall be based on the statutory provisions, unless otherwise agreed below. The special statutory provisions for final delivery of the unprocessed goods to a consumer, even if this consumer has further processed these goods, shall remain unaffected in all cases (supplier regress according to §§ 478 BGB). Claims arising from the supplier regress are excluded if the defective goods were subject to further processing, e.g. by installation in another product, by the customer or another company.
- (2) Our liability for defects is based primarily on the agreement reached concerning the quality of the goods. All product descriptions and manufacturer's specifications that form part of an individual contract or that were published by us (specifically in catalogues or on our website) at the time of contract conclusion are deemed to be agreements concerning the quality of the goods.
- (3) Insofar as the quality was not agreed, the existence of a defect shall be evaluated according to the statutory provision (§ 434 par. 1 p. 2 and 3 BGB). However, we accept no liability for public statements by third parties (e.g., advertising statements) to which the customer has not drawn our attention as having influenced his/her purchasing decision.
- (4) In principle, we accept no liability for defects that the customer is aware of, or unaware of due to gross negligence, at the time of conclusion of the contract (§ 442 BGB). Furthermore, the customer's claims for defects require that the customer has fulfilled his/her statutory examination and reporting obligations (§§ 377, 381 German Commercial Code (HGB)). In the case of goods intended for installation or other further processing, an investigation must be carried out in all cases immediately prior to processing. If a defect is discovered during the delivery, the investigation or at any subsequent time, we must be notified of this in writing immediately. In all cases, obvious defects must be reported in writing within 5 working days of delivery and non-visible defects undiscovered during the investigation must be reported in writing within the same period following discovery. If the customer fails to carry out a proper investigation and/or report defects, our liability for defects that are not reported, not reported in time or not reported properly shall be excluded in accordance with the statutory provisions.
- (5) If the item delivered is defective, we can initially choose whether to provide subsequent performance by eliminating the defect (rectification) or by delivering a defect-free item (replacement delivery). This does not affect our right to refuse subsequent performance in accordance with statutory requirements.
- (6) S+S is entitled to refuse subsequent performance if this is only possible at disproportionate costs. Disproportionate costs are deemed to apply if the costs of subsequent performance, including the cost of removing the defective item and installing a defect-free item, exceed the value of the goods in their defect-free condition by 200%.
- (7) S+S is entitled to make the subsequent performance owed dependent on the purchaser paying the purchase price due. However, the purchaser is entitled to withhold a portion of the purchase price that is commensurate with the defect.





- (8) The purchaser must provide us with the necessary time and opportunity to carry out the subsequent performance owed and, in particular, must hand over the rejected goods to us. In the event of a replacement delivery, the purchaser must return the defective item to us in accordance with the statutory provisions.
- (9) In the case of subsequent performance, S+S itself shall remove the defective item and install the defect-free item. The customer is only entitled to remove the defective item and to install a defect-free item with the prior consent of S+S or following the expiry of an appropriate deadline set by the customer. Insofar as a defect actually exists, we will bear or reimburse in accordance with statutory provisions the expenditure incurred for the purpose of inspection and subsequent performance, in particular, transport, travel, labour and material costs as well as any applicable removal and installation costs. Otherwise, we are entitled to demand reimbursement from the customer for the costs incurred due to the unwarranted request for defect rectification (in particular, inspection and transport costs), unless the purchaser was unable to ascertain the freedom from defects.
- (10) If the subsequent performance has failed or if an appropriate deadline to be set by the customer for the subsequent performance has expired without success or is dispensable in accordance with the statutory provisions, the purchaser is entitled to withdraw from the contract or reduce the purchase price. However, the right of withdrawal does not apply for insignificant defects.
- (11) Claims by the purchaser for damages or compensation for wasted expenditure apply even for defects only in accordance with § 8 and are excluded in all other cases.

#### 7. Warranty

- (1) S+S grants a warranty for products that the customer has purchased on or after 1 January 2021 subject to the following provisions. This warranty is provided to customers in addition to and independently of their statutory entitlements in the event of defects.
- (2) S+S will rectify any faults in the design, material or workmanship by repair or replacement delivery within 5 years of delivery. The usual signs of wear, especially due to corrosion, ageing as well as ambient and environmental influences, are excluded from the warranty.
- (3) The warranty only covers the repair or replacement delivery at the discretion of S+S. The warranty does not cover the removal of the defective item and installation of the new defect-free item.
- (4) The assertion of warranty claims requires that the product be purchased on or after 1 January 2021 and was installed and maintained by a qualified technician in compliance with the mounting and operation handouts of S+S.
- (5) The warranty shall expire if the fault is caused by improper installation, operating, usage or handling, or if the product was subject to structural modifications after it was purchased or was repaired or modified using third-party components.
- (6) When a warranty claim is submitted, the product must be sent, securely packaged, accompanied by a complaint number that must be requested from S+S by telephone or by e-mail to "S+S Regeltechnik GmbH, Reklamationsabteilung, Thurn-und-Taxis-Str. 22, D-90411 Nürnberg, Germany". The customer bears all shipping costs. The copy of the invoice with purchase date and the completed "Form for Returns", which can be downloaded at <https://spluss.de/en/downloads/>, must be enclosed with the shipment.

#### 8. Liability

- (1) Unless otherwise specified in these General Terms and Conditions of Sale and Delivery including the following provisions, S+S shall be liable for breaches of contractual and non-contractual obligations in accordance with the statutory provisions.
- (2) S+S is liable for damages – irrespective of the legal grounds – in the case of fault-based liability arising from intent and gross negligence. In the case of simple negligence, S+S shall be liable based on a more lenient liability standard in accordance with statutory provisions (e.g., for care and attention regarding internal matters) only
- for damage arising from the injuries to life and limb or to health;
  - for damage arising from the violation of a material contractual obligation, the fulfilment of which enables the proper execution of the contract in the first place and on whose fulfilment the customer can normally rely on and is entitled to rely on; in this case, however, liability is limited to compensation of the typically foreseeable level of damage.
- (3) The liability limitations arising from number 8 (2) also apply for breaches of duty by or in favour of persons for whose fault S+S is responsible in accordance with statutory provisions. They shall not apply insofar as S+S has maliciously concealed a defect or has assumed a warranty for the quality of the goods and for claims by the customer in accordance with the German Product Liability Act.
- (4) S+S can only be held liable for deliberate breach of duty and not for any consequential damage caused by further processing of unsuitable or defective goods.

#### 9. Limitation period

- (1) Contrary to § 438 par. 1 no. 3 BGB, the general limitation period for claims arising from material defects and defects of title is one year after delivery.
- (2) However, if the good in question is a building or an item that has been used in accordance with its customary purpose for a building and has caused it to be defective (building material), the limitation period according to the statutory provision is 5 years of delivery (§ 438 par. 1 no. 2 BGB). Additional statutory special regulations regarding the limitation period, especially in accordance with § 438 par. 1 no. 1 BGB, also remain unaffected if S+S has maliciously concealed the defect or assumed a warranty for the quality of the goods (§ 438 par. 3, § 444 BGB) or in the case of supplier regress in the sale of consumer goods in accordance with §§ 478, 479 BGB.
- (3) The above limitation periods specified in legislation covering the sale of goods also apply for contractual and non-contractual claims for compensation by the customer that are based on a defect of the goods, unless application of the normal statutory limitation period (§§ 195, 199 BGB) would in this particular case result in a shorter limitation period. Claims for compensation by the customer in accordance with number 8 (2) clause 1 and clause 2 (a) and in accordance with the product liability law shall come under the statute of limitations exclusively in accordance with the statutory limitation periods.

#### 10. Retention of title

- (1) The goods delivered shall remain the property of S+S until the complete settlement of any and all claims by the customer. If the customer sells reserved goods without receiving the purchase price from its buyers on a payment-on-delivery basis or in advance, the customer shall agree the reservation of title with its buyers in accordance with these provisions.
- (2) The customer is not entitled to pledge the reserved goods or to transfer them as collateral. In the event of seizures or other interventions by third parties, the customer shall notify S+S in writing without delay.
- (3) The customer is entitled to resell reserved goods during the course of its regular business operations. The customer now already assigns to S+S all receivables in the amount of the total invoice amount (including VAT) of the claim that are accruing to the customer from its buyers from the resale, irrespective of whether such goods are sold either without or after processing. The customer is also still entitled to collect the receivable after assignment, although this does not affect the entitlement of S+S to collect the outstanding amount itself. However, S+S undertakes to the customer not to collect the outstanding amount as long as the customer does not fall behind with payments, or an application to initiate a judicial settlement or insolvency proceedings has not been filed. If this is the case, the customer is obligated at the request of S+S to disclose the assigned receivables and their debtors, to provide the necessary records, and to notify the debtors of the assignment.

#### 11. Operating and mounting instructions

The customer undertakes to adhere to any operating and mounting instructions delivered with goods, and to make any third-party buyers aware of same. The complete or partial non-observance of such instructions may result in a complete loss of buyers' rights. This does not apply to possible claims for damages according to § 7.

#### 12. Copyright

The customer is not entitled to reproduce or copy any of the content of S+S catalogues, specifically technical drawings and photographs, for his/her own advertising or other purposes without the express written approval of S+S. The customer is not permitted to make quotations or other commercial documents available to third parties.

#### 13. Miscellaneous

- (1) For any disputes arising from or in connection with the contractual relationship, Nuremberg/Germany is agreed as the place of jurisdiction. The place of performance is Nuremberg.
- (2) The customer can only offset against claims that are undisputed or have been legally established as final and absolute. The customer is entitled to a right of retention only if its counter-claims originate from the very same contractual relationship, or if such claims are undisputed or have been legally established as final and absolute.
- (3) Modifications of the contract must be made in writing. This also applies to the alteration of this written-form requirement clause.
- (4) Should one or several provisions of these General Terms and Conditions of Sale and Delivery be ineffective or not have been properly incorporated into the contract, the remaining provisions of these General Terms and Conditions of Sale and Delivery shall remain effective.
- (5) Solely the laws of the Federal Republic of Germany shall apply to the exclusion of the law regarding the United Nations Convention on Contracts for the International Sale of Goods (CISG) – also if the customer has its registered office outside Germany.

These General Terms and Conditions of Sale and Delivery are protected by copyright. Copyright infringements will be legally prosecuted.



# You can rely on S+S – We have the paperwork to prove it!

When it comes to quality, we leave nothing to chance. We make sure of this with systematic quality management and uncompromising checks at our in-house testing centre. In addition, we undergo

regular certification by independent inspection authorities and institutions. We are very proud that our quality 'Made in Germany' also passes the strictest international inspections and tests again and again with flying colours.



## Approved Safety



DIN tested/certified devices



RoHS conforming materials



ESD compliant manufacturing



CE compliance tested by external laboratories

## Certified Quality

Our development and production in Nuremberg /Germany is certified by TÜV Thüringen according to DIN EN ISO 9001:2015.



GOST certificates for exports of all products by S+S Regeltechnik GmbH to the Commonwealth of Independent States and Russia



EAC certified

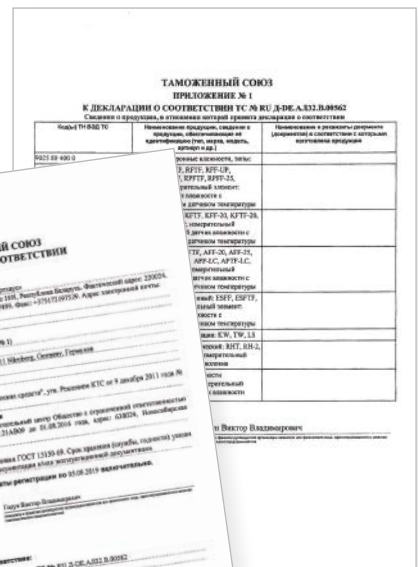
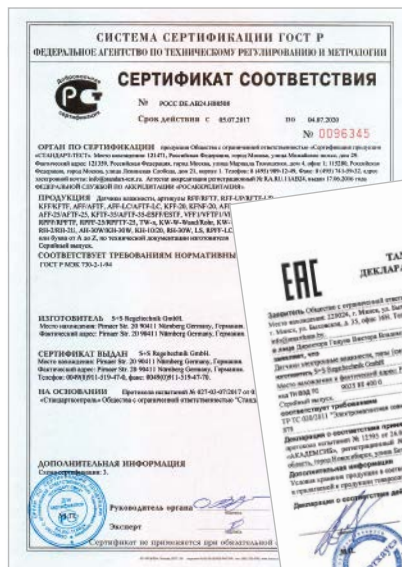





S+S REGELTECHNIK

ZERTIFIKAT • CERTIFICATE • CERTIFICADO • CERTIFICATO • CERTIFICADO

**ZERTIFIKAT**  
 gültig bis: 29.02.2019  
**CERTIFICATE**  
 valid until: 29.02.2019

EU-Type examination (product B) - Baukasten - nach Richtlinie 2014/53/EU  
EU Type examination (product B) - production type - according to Directive 2014/53/EU

Zertifikat-Nr.: **Z-45-TAF-MUC-18-03-282130-002**  
Certificate No.: **Z-45-TAF-MUC-18-03-282130-002**

Name und Anschrift des Herstellers:  
Name and address of manufacturer:  
**S+S Regeltechnik GmbH  
Pinner Str. 20  
90411 Nürnberg**

Name und Anschrift des Prüfinstituts:  
Name and address of manufacturer:  
**S+S Regeltechnik GmbH  
Pinner Str. 20  
90411 Nürnberg**

Prüfbericht Nr.: **C-T 1382-0118 vom 2018-03-26**  
Evaluation report No.: **C-T 1382-0118 dated 2018-03-26**

Geltungsbereich:  
Scope of examination:  
Sicherheitsteiltemperaturbegrenzer  
an Ausdehnung mit Sicherheitsfunktion  
Typ: ETR und KTR (siehe Seite 3)  
Pressure regulating device (see page 3)

Fertigungsstätte:  
Production site:  
**S+S Regeltechnik GmbH  
Pinner Str. 20  
90411 Nürnberg**

München, 29.02.2019  
(Date, Date)  
TÜV SÜD Industrie Service GmbH  
Certification Body for pressure regulation  
Johannes Bredenkopf  
180 930-1027  
Nürnberg, 29.02.2019  
(Date, Date)  
TÜV SÜD Industrie Service GmbH  
Certification Body for pressure regulation  
Johannes Bredenkopf  
180 930-1027

Page 1 of 4 certificate No. 15661 15661/18, Z-45-TAF-MUC-18-03-282130-002

ZERTIFIKAT • CERTIFICATE • CERTIFICADO • CERTIFICATO • CERTIFICADO

**CERTIFICATE**  
 gültig bis: 29.02.2019  
**ZERTIFIKAT**  
 valid until: 29.02.2019

EU Type examination (product B) - Baukasten - nach Richtlinie 2014/53/EU  
EU Type examination (product B) - production type - according to Directive 2014/53/EU

Zertifikat-Nr.: **Z-45-TAF-MUC-18-03-282130-002**  
Certificate No.: **Z-45-TAF-MUC-18-03-282130-002**

Name und Anschrift des Herstellers:  
Name and address of manufacturer:  
**S+S Regeltechnik GmbH  
Pinner Str. 20  
90411 Nürnberg**

Name und Anschrift des Prüfinstituts:  
Name and address of manufacturer:  
**S+S Regeltechnik GmbH  
Pinner Str. 20  
90411 Nürnberg**

Prüfbericht Nr.: **C-T 1382-0118 vom 2018-03-26**  
Evaluation report No.: **C-T 1382-0118 dated 2018-03-26**

Geltungsbereich:  
Scope of examination:  
Safety temperature limiter as safety accessory  
type ETR and KTR (see page 3),  
back of examination and details see page 3

Fertigungsstätte:  
Production site:  
**S+S Regeltechnik GmbH  
Pinner Str. 20  
90411 Nürnberg**

München, 29.02.2019  
(Date, Date)  
TÜV SÜD Industrie Service GmbH  
Certification Body for pressure regulation  
Johannes Bredenkopf  
180 930-1027  
Nürnberg, 29.02.2019  
(Date, Date)  
TÜV SÜD Industrie Service GmbH  
Certification Body for pressure regulation  
Johannes Bredenkopf  
180 930-1027

Page 1 of 4 certificate No. 15661 15661/18, Z-45-TAF-MUC-18-03-282130-002

ZERTIFIKAT • CERTIFICATE • CERTIFICADO • CERTIFICATO • CERTIFICADO

**СЕРТИФИКАТ**  
 Certificate  
 gültig bis: 29.02.2019  
Испытание ЕС типового образца (продукт В) в соответствии с Директивой 2014/53/ЕС

EU Type examination (product B) - Baukasten - nach Richtlinie 2014/53/EU  
EU Type examination (product B) - production type - according to Directive 2014/53/EU

Zertifikat-Nr.: **Z-45-TAF-MUC-18-03-282130-002**  
Certificate No.: **Z-45-TAF-MUC-18-03-282130-002**

Name und Anschrift des Herstellers:  
Name and address of manufacturer:  
**S+S Regeltechnik GmbH  
Pinner Str. 20  
90411 Nürnberg**

Name und Anschrift des Prüfinstituts:  
Name and address of manufacturer:  
**S+S Regeltechnik GmbH  
Pinner Str. 20  
90411 Nürnberg**

Prüfbericht Nr.: **C-T 1382-0118 vom 2018-03-26**  
Evaluation report No.: **C-T 1382-0118 dated 2018-03-26**

Geltungsbereich:  
Scope of examination:  
Safety temperature limiter as safety accessory  
type ETR and KTR (see page 3),  
back of examination and details see page 3

Fertigungsstätte:  
Production site:  
**S+S Regeltechnik GmbH  
Pinner Str. 20  
90411 Nürnberg**

München, 29.02.2019  
(Date, Date)  
TÜV SÜD Industrie Service GmbH  
Certification Body for pressure regulation  
Johannes Bredenkopf  
180 930-1027  
Nürnberg, 29.02.2019  
(Date, Date)  
TÜV SÜD Industrie Service GmbH  
Certification Body for pressure regulation  
Johannes Bredenkopf  
180 930-1027

Page 1 of 4 certificate No. 15661 15661/18, Z-45-TAF-MUC-18-03-282130-002

**ZERTIFIKAT**

für das Managementsystem  
nach DIN EN ISO 9001:2015

Die regelwerkskonforme Anwendung wurde nachgewiesen und wird gemäß Zertifizierungsverfahren bescheinigt für das Unternehmen

**S + S Regeltechnik GmbH**  
Thurn-und-Taxis-Straße 22  
90411 Nürnberg

Geltungsbereich  
Entwicklung, Herstellung und Vertrieb von Sensoren, Fühlern und Feldgeräten für die Gebäude-, Versorgungstechnik und Infrastrukturautomation

Zertifikat-Registrier-Nr.: TIC 15 100 21333 Gültig bis: 2023-06-22  
Audit Bericht Nr.: 3330 208P UD Gültig ab: 2020-06-28

Diese Zertifizierung wurde gemäß TIC-Verfahren zur Ausdehnung und Zertifizierung durchgeführt und wird regelmäßig überwacht.

München, 2021-07-15  
TÜV Thüringen e.V. / Certification body for systems and personnel  
Jana 2021-07-15  
TÜV Thüringen e.V. / Certification body for systems and personnel

Page 1 of 4 certificate No. 15661 15661/18, Z-45-TAF-MUC-18-03-282130-002

**CERTIFICATE**

for the management system  
according to ISO 9001:2015

The proof of the conforming application with the regulation was furnished and in accordance with certification procedure it is certified for the company

**S + S Regeltechnik GmbH**  
Thurn-und-Taxis-Straße 22  
90411 Nürnberg / Germany

Scope  
Development, production and sale of sensors, detectors and field instruments for building, supply technology and infrastructure automation

Certificate Registration No.: TIC 15 100 21333 Valid until: 2023-06-22  
Audit Report No.: 3330 208P UD Valid from: 2020-06-28

This certification was conducted in accordance with the TIC building and certification procedures and is subject to regular surveillance audits.

München, 2021-07-15  
TÜV Thüringen e.V. / Certification body for systems and personnel  
Jana 2021-07-15  
TÜV Thüringen e.V. / Certification body for systems and personnel

Page 1 of 4 certificate No. 15661 15661/18, Z-45-TAF-MUC-18-03-282130-002

**СЕРТИФИКАТ**

соответствия системы менеджмента  
требованиям стандарта ISO 9001:2015

В соответствии с правилами сертификации подтверждено выполнение требований стандарта в организации

**S + S Regeltechnik GmbH**  
Thurn-und-Taxis-Straße 22  
90411 Nürnberg / Германия

в области:  
Разработка, производство и сбыт сенсоров, зондов, регулирующих и контрольных приборов для автоматизации сооружений и инфраструктуры

Регистрационный номер сертификата: TIC 15 100 21333 Действителен до: 2023-06-22  
Отчет по аудиту №: 3330 208P UD Действителен с: 2020-06-28

Сертификация проведена в соответствии с процедурами подтверждения и сертификации TIC и предусматривает регулярное наблюдательное аудиторское.

München, 2021-07-15  
TÜV Thüringen e.V. / Certification body for systems and personnel  
Jana 2021-07-15  
TÜV Thüringen e.V. / Certification body for systems and personnel

Page 1 of 4 certificate No. 15661 15661/18, Z-45-TAF-MUC-18-03-282130-002

**ZERTIFIKAT**

Zertifikatinhaber: **S + S Regeltechnik GmbH  
Pinner Str. 20  
90411 Nürnberg**

Produkt: **Temperaturregel- und Regelungsarten für Wärmeenergieanlagen**

Typ, Modell: **ETR-080, ETR-090, ETR-10140, ETR-1, ETR-0120  
KTR-040, KTR-060, KTR-01040, KTR-1, KTR-0120  
DIN EN 14597-2015-02  
Zertifizierungsprogramme Temperaturregel- und Regelungsarten für Wärmeenergieanlagen (2020-01)**

Prüfungsinhalt(e)  
Konformitätsnachweise

Registrierungsnummer: **TR119**  
Gültig bis: **2023-02-28**  
Ausgaberecht: Dieses Zertifikat berechtigt zum Führen des oben stehenden Konformitätsnachweises in Verbindung mit der jeweiligen Registrierungsnummer. Weitere Angaben siehe Anhang.

München, 2021-02-28  
DIN CERTCO  
DIN CERTCO  
DIN CERTCO  
DIN CERTCO

Page 1 of 4 certificate No. 15661 15661/18, Z-45-TAF-MUC-18-03-282130-002

**CERTIFICATE**

Certificate holder: **S + S Regeltechnik GmbH  
Pinner Str. 20  
90411 Nürnberg  
GERMANY**

Product: **Temperature control and limiting devices for heat generating systems**

Typ, Modell: **ETR-080, ETR-090, ETR-10140, ETR-1, ETR-0120  
KTR-040, KTR-060, KTR-01040, KTR-1, KTR-0120  
DIN EN 14597-2015-02  
Certification scheme Temperature control and limiting devices for heat generating systems (2020-01)**

Testing basis  
Mark of conformity

Registration No.: **TR119**  
Valid until: **2023-02-28**  
Issuance right: This certificate entitles the holder to use the mark of conformity shown above in conjunction with the specified registration number. See annex for further information.

München, 2021-02-28  
DIN CERTCO  
DIN CERTCO  
DIN CERTCO  
DIN CERTCO

Page 1 of 4 certificate No. 15661 15661/18, Z-45-TAF-MUC-18-03-282130-002

**СЕРТИФИКАТ**

Владелец сертификата: **S + S Regeltechnik GmbH  
Pinner Str. 20  
90411 Nürnberg  
Германия**

Наименование продукции: **УСТРОЙСТВА КОНТРОЛЯ И ОГРАНИЧЕНИЯ ТЕМПЕРАТУРЫ**

Тип, модель: **ETR-080, ETR-090, ETR-10140, ETR-1, ETR-0120  
KTR-040, KTR-060, KTR-01040, KTR-1, KTR-0120  
DIN EN 14597-2015-02  
Программы сертификации устройств контроля и ограничения температуры для теплоэнергетических систем (2020-01)**

Основание для выдачи сертификата

Регистрационный номер: **TR119**  
Действителен до: **2023-02-28**  
Право на использование знака: Национальный сертификат дает право на использование вышеназванного знака соответствия вместе с передаваемым регистрационным номером. Дополнительная информация - см. приложение.

München, 2021-02-28  
DIN CERTCO  
DIN CERTCO  
DIN CERTCO  
DIN CERTCO

Page 1 of 4 certificate No. 15661 15661/18, Z-45-TAF-MUC-18-03-282130-002



## Order conveniently in our online shop

You can easily place orders online and pay securely 24/7.  
 All items from the **S+S facility engineering** product range  
 are immediately available from stock.  
 On weekdays we ship within 24 hours



[www.PlusS.de](http://www.PlusS.de)



Order and pay  
conveniently 24 / 7



All catalogue items  
immediately available



24h shipping



## At Your Service

All of our staff members are specialists in their jobs and know how to contribute to your satisfaction.

You can reach our motivated team by phone, email or fax.

Don't hesitate to contact us – now!



**Contact us by phone:**

**+49 (0) 911-519 47-0**



**Write us an email:**

**mail@SplusS.de**



**Send us a fax:**

**+49 (0) 911-519 47-70**



S+S REGELTECHNIK



S+S REGELTECHNIK GMBH  
THURN-UND-TAXIS-STR. 22  
90411 NUREMBERG / GERMANY

PHONE +49 (0) 911 / 5 19 47-0  
FAX +49 (0) 911 / 5 19 47-70  
FAX +49 (0) 911 / 5 19 47-73

mail@SplusS.de  
www.SplusS.de

FÜHLBARE PRÄZISION